

Service manual for TEMPERATURE CALIBRATOR TC305/TC303



Dear user,

We have made every effort to ensure the accuracy of the contents of this manual. Should any errors be detected, we would greatly appreciate to receive suggestions to improve the quality of the contents of this manual.

The above notwithstanding, we can assume no responsibility for any errors in this manual or their eventual consequences.

We reserve rights to make modifications to this manual without any further notice.

For more detailed technical data about the Service manual for TC305/TC303, please contact the manufacturer.

© Copyright 1997

OY BEAMEX AB
P.O. Box 5
68601 Pietarsaari
FINLAND

Tel +358 - 6 - 7840111
Fax +358 - 6 - 7840404
E-mail: sales@beamex.com
Internet: <http://www.beamex.com>

8830100 / SETC305 / 912417

CONTENTS

PART A. FUNCTIONAL DESCRIPTION

1 GENERAL	A - 1
2 SECTION A	A - 2
3 SECTION B	A - 3

PART B. SERVICE

1 WARNING DURING OPERATION	B - 1
2 HARDWARE ERROR MESSAGES	B - 2
3 SERVICE, TROUBLESHOOTING AND REPAIR	B - 4
3.1 Disassembling and reassembling the calibrator	B - 4
3.2 Updating the software version	B - 5
3.3 Installing software options	B - 5
3.4 Replacing the battery pack	B - 6
3.5 Hardware troubleshooting	B - 6
3.5.1 Front assembly	B - 7
3.5.1.1 Display and keypad board	B - 7
3.5.1.2 Battery pack	B - 7
3.5.1.3 Power supply board	B - 8
3.5.2 Analog i/o assembly	B - 9
3.5.3 Processor boards	B - 10
3.5.4 Optional 24V supply board	B - 10

PART C. CALIBRATION

1 GENERAL	C - 1
2 EQUIPMENT REQUIRED FOR CALIBRATION	C - 1
3 PREPARATIONS BEFORE CALIBRATION	C - 3
4 SECTION B MEASUREMENTS	C - 4
5 SECTION A MEASUREMENTS	C - 6
6 RESISTANCE SIMULATION	C - 8
7 INTERNAL REFERENCE JUNCTION COMPENSATION	C - 10
7.1 Calibration with thermocouple	C - 11
7.2 Calibration with a thermometer	C - 12

8 CALIBRATION DATE	C - 13
9 AUTO CALIBRATION OF GENERATION RANGES.....	C - 14
10 CALIBRATION PERIOD	C - 15

PART D. SERIAL COMMUNICATION

1 GENERAL	D - 1
2 TECHNICAL SPECIFICATIONS	D - 2
2.1 Flow control (XON/XOFF)	D - 2
2.2 Checksum.....	D - 2
2.3 Acknowledgment (ACK/NAK)	D - 3
2.4 Line terminators (CR/LF)	D - 3
3 COMMANDS	D - 4
3.1 Interface configuration and control.....	D - 5
3.1.1 Communication control.....	D - 5
3.1.2 Line termination	D - 5
3.1.3 Control of sent measurement/generation readings.....	D - 6
3.1.4 Use of status codes	D - 6
3.1.5 Formatting of readings.....	D - 7
3.2 Device configuration	D - 8
3.2.1 A-section (upper display) electrical unit selection.....	D - 8
3.2.2 A-section temperature / electrical mode selection	D - 8
3.2.3 Temperature sensor selection.....	D - 9
3.2.4 Temperature scale.....	D - 9
3.2.5 CJ-selection	D - 10
3.2.6 Generation value setting	D - 10
3.2.7 Emulation of mechanical switch settings	D - 10
3.2.8 B-section (lower display) electrical unit selection	D - 11
3.2.9 Local on/off	D - 11
3.3 Calibration and service	D - 12
3.4 Commands for key emulation / inquiry.....	D - 13
3.5 Other standard commands.....	D - 14
3.5.1 System details	D - 14
3.5.2 Set/get date	D - 14
3.5.3 Display message	D - 15
3.6 Special commands	D - 16

APPENDIXES

APPENDIX A: STATUS CODE / ERROR MESSAGES IN SERIAL COMMUNICATION	X - 1
APPENDIX B: MEASUREMENT PRINTOUT FORMAT	X - 2
APPENDIX C: ALGORITHMS.....	X - 4
APPENDIX D: PC106P RS-232 SAVEABLE OPTIONS	X - 4

FUNCTIONAL DESCRIPTION

1 GENERAL

The functions of TC305/TC303 temperature calibrator are divided in two sections. The left side of the connection panel and the upper display constitute the Measure/Generate section which is called the A-section. The right side of the connection panel and the lower display constitute the Measure section, called here the B-section.

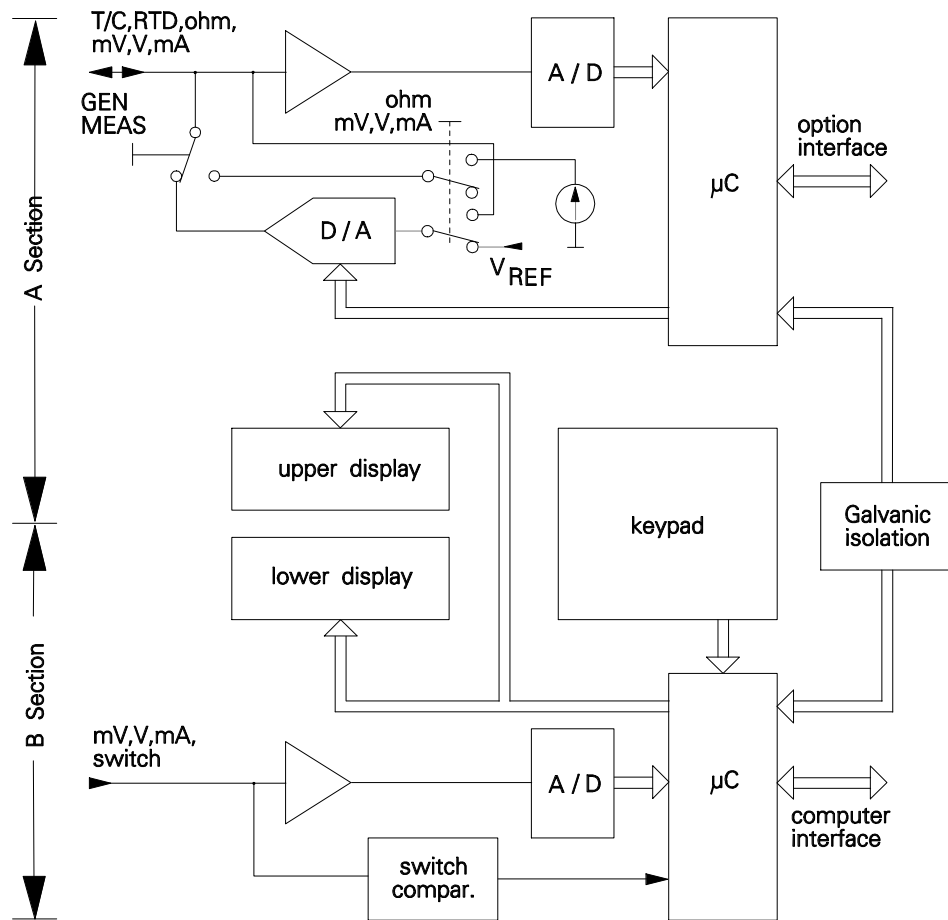

TC305 simplified block diagram

2 SECTION A

The A-section microprocessor takes care of electrical measurements and generations/simulations. It also makes all calculations required for temperature sensor simulations and measurements. It uses one A/D-converter for all these measurements and one D/A-converter for generations/simulations.

In resistance measurement TC305/TC303 generates the measurement current and measures the voltage across the resistance. It switches off the current for a part of the time. This enables compensation of the thermovoltages in the resistance measurement circuit.

In voltage and current generation TC305/TC303 makes the output with the D/A-converter and assures the accuracy by continuously measuring the generated value.

In resistance simulation there should be an external resistance measurement device measuring the resistance between the TC305/TC303 output terminals. The D/A-converter detects the measurement current coming from the external measurement device. It controls the voltage across the resistance output terminals so that it is in the correct ratio to the detected current. The microprocessor defines this ratio according to the Ohm's law and the simulated resistance value.

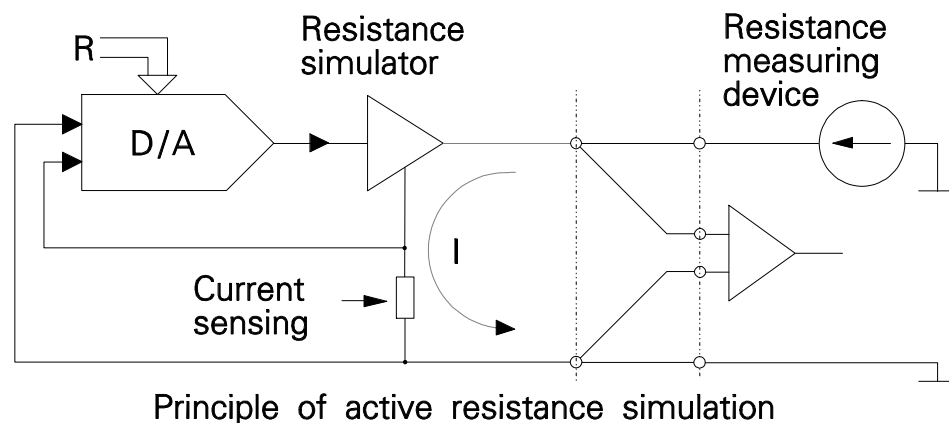

Theoretically the resistance simulation could be able to simulate the given resistance also to an AC circuit. In practice, anyhow, it is always too slow to achieve reasonable accuracy, if the measurement device uses AC supply for resistance measurement. Fortunately AC measurement of resistance is very seldom used nowadays.

Some resistance measurement devices - like TC305/TC303 itself - use pulsed current for resistance measurement. Simulation to these devices is possible with TC305/TC303. The measurement device should, however, give enough time for the circuits to settle after switching the current on. This is normally necessary also because of the inductance and capacitance of the industrial resistance measurement circuits.

3 SECTION B

The B-section microprocessor uses another A/D-converter to measure current or voltage. There are also circuits for switch state detection. There is a galvanic isolation between the two sections. This enables you to generate the input of an instrument and simultaneously measure the instrument output.

The B-section microprocessor also carries out the communication with the user and with the computer via the serial computer interface.

SERVICE

1 WARNING DURING OPERATION

If you try to use TC305/TC303 in a strange way, it may warn you about it. The following list explains the used warning messages in detail.

NO TCAL	Attempt to start Quick Store or Quick Examine function when TCAL305 expansion software is not installed.
NO ID	No instrument identifier defined.
CLEAR AREA	No instrument data in the loaded memory area.
UNDEFD SENSOR	Attempt to load instrument data from Data Memory. The defined sensor type was not known and loading was denied. If a special sensor is included in the instrument data and the special sensor is no longer fixed to the defined special sensor place, the required special sensor arrow is lit.
CONFIG ERROR	Attempt to start the Quick Store function with faulty configuration, e.g. the instrument type is FREE.
SCAN ERROR	The actuation or deactuation point of a limit switch out of the scan limits or scan limits out of the generation/simulation range of the calibrator.
NOT SAVED	Attempt to change the contents of the Working Memory without saving the results of the latest Quick Store to the Data Memory.
CANCEL STORE	Escaping from Quick Store before altering the contents of the Working Memory.
DATA LOST	TC305/TC303 has lost its configuration data, instrument data and calibration results due to the missing RAM backup voltage. The obvious reason is, that the battery has been disconnected for a while or empty battery has not been recharged in time. Switch the calibrator off and check the battery wiring, recharge the battery or replace it if necessary. If the error remains, send TC305/TC303 to Beamex or representative for repair.

DATE LOST	TC305/TC303 calendar/clock has lost the date and time due to the missing backup voltage. The obvious reason is, that the battery has been disconnected for a while or empty battery has not been recharged in time. Check the battery wiring, recharge the battery or replace it if necessary. Enter the new date and time as explained in part C of this manual. If the error remains, send TC305/TC303 to Beamex or representative for repair.
CALIBR SOON	According to the given calibration period, you should soon recalibrate the TC305/TC303 calibrator.
NO CAL DATA	This message is used in new devices before the initial definition and calibration. It should not come in sold devices. However, if it comes, there is fault in the EEPROM memory. TC305/TC303 has lost all calibration data. Do not use it for calibration purposes. Send it to the manufacturer for repair.
NO DATA	Attempt to use the Quick Examine function when the Working Memory is empty.
NO FREQ MODULE	The instrument to be calibrated requires a frequency module or the settings of the frequency module does not correspond to the requirements. The inverted arrows in TC305/TC303 display the settings needed for the operation. This applies for software versions 1.31 and later. In earlier software versions the message was " BAD FRQ UNIT x ".

2 HARDWARE ERROR MESSAGES

If TC305/TC303 detects errors in its internal functions, it denies all operations and shows an error code:

**ERROR
CODE n**

The error code helps to decide, how to correct the error.

Error codes:

- 1 The A-section microprocessor doesn't answer when called from the B-section.
- 2 Fault in the B-section analog part.
- 3 Checksum error in EEPROM memory.
- 4 Fault in the A-section analog part.
- 5 Error in the A-section digital part.
- 6 Error in the clock/calendar circuit.
- 7 The watchdog circuit detected fault in operation during previous use.
- 8 Errors in communication between A- and B-sections.
- 9 Software option data in EEPROM corrupted.
- 10 According to A/D-converter readings, the A-section analog part is faulty.

The messages give some idea, where the error might be. You can't, however, make any absolutely sure conclusions of them. Error codes 2,3,4,9 and 10 normally show that the error is in the analog i/o assembly. Error codes 6 and 7 mean that the main processor board is faulty. Obvious cause for the error code 5 is on the temperature processor board. Errors 1 and 8 may be caused by a fault on either one of the two processor boards. In all cases the actual fault can be in cabling between the boards. In some cases the fault is said to be in the analog i/o assembly but it actually is on one of the processor boards or vice versa. Fault on the power supply board can cause practically any malfunction or error message.

3 SERVICE, TROUBLESHOOTING AND REPAIR

If you can't switch the calibrator on at all, the most obvious fault is empty battery. If charging doesn't help, check the battery voltage from the battery terminals. If the battery is ok, but you still can't start the calibrator, the fault is obviously in internal cabling or on the main processor board. If your device stops and shows an error code, write down the shown code number and switch the calibrator off. Wait five seconds and switch the calibrator on to see, if the error remains. If the error remains or repeats later, see the following chapters for more help. Only board level service is explained. Component level trouble shooting would require detailed knowledge both of the hardware and of the software.

If the fault is obvious or if you can locate it using the information given in this manual, you can perhaps repair it locally. Otherwise, send the device to the manufacturer or to the representative for repair. In case of warranty repair, always send the device to us or to our representative. Most representatives can carry out board level trouble shooting and replace faulty boards or units.

3.1 Disassembling and reassembling the calibrator

The calibrator must be taken apart in case of software update, read/write memory installation, battery replacement or hardware trouble shooting. The following steps are required to disassemble TC305/TC303:

- * Switch off the calibrator.
- * Loosen the four screws on the bottom of the calibrator.
- * Carefully lift the rear of the cover and remove the cover.
- * Remove the handle and the handle springs.
- * Remove the two screws holding the front assembly.
- * Loosen the front assembly cable connectors from the processor boards below it and from the analog i/o assembly.
- * Remove the four screws on the front and rear of the analog i/o assembly.
- * Lift the analog i/o assembly and loosen its cable connectors from the processor boards.

Reassembling requires opposite steps. If the front assembly has been removed, TC305/TC303 loses date, time and all data stored in the read/write memory. This includes Working Memory, Data Memory and all configuration settings. Calibration data as well as installation of software options do not change, because they are stored in the non-volatile EEPROM memory. Setting of date, time and all configurations is explained in part C of the instruction manual. After disassembly, TC305/TC303 may show error message 'ERROR CODE 7'. If this happens, switch the unit off for 5 seconds and try to switch on again.

Note:

When disassembling a TC305/TC303, all special sensor definitions will be

lost. After reassembling, refer to chapter "*Special sensor definition*" in part C of the Instruction manual to fix your additional sensor to a special sensor number.

3.2 Updating the software version

TC305/TC303 software is stored in two EPROM memories, one on each processor board on the bottom of the calibrator. The left side (front view) processor board is named 'main processor board' and the right side processor board is 'temperature processor board'. The EPROMs are labeled 'Main Processor' and 'Temp. Processor' respectively. To install a new software version, follow the updating instructions delivered with the new EPROM(s).

3.3 Installing software options

To be able to install software options, you must purchase the license for the option from us. The license is delivered in form of security codes. To be able to generate the codes, we need the serial number of the calibrator as well as the serial number of the analog i/o assembly of the calibrator.

To read the serial numbers, select the configuration menu entry

```
CONF  
<OTHERS>      (quick select CONF STO)
```

To the prompt

```
C.CODE?  
enter the code  
101 ENT
```

For example the display

```
C.330  
E.10234
```

means that the serial number of the calibrator is 330 (should be the same as marked on the connection panel) and the serial number of the analog i/o assembly is 10234.

Write the numbers on paper and press ESC to exit. Contact us for further operations.

3.4 Replacing the battery pack

If you recharge the battery regularly, it can be used years without replacement. When the battery gets old, its capacity decreases and it can not be used long enough between recharges.

To replace the battery pack:

- * Remove the cover of the calibrator.
- * Open the screws of the battery pack cover and remove the cover.
- * Loosen the battery pack wire connectors from the power supply board.
- * Install the new battery pack in reverse order.

The battery replacement should be done with the battery charger connected to prevent loss of data stored in the read/write memory. Otherwise TC305/TC303 loses date, time and all data stored in the read/write memory. This includes Working Memory, Data Memory and all configuration settings. Calibration data as well as installation of software options do not change, because they are stored in the non-volatile EEPROM memory. Setting of date, time and all configurations is explained in part C of the instruction manual. After disassembly, TC305/TC303 may show error message 'ERROR CODE 7'. If this happens, switch the unit off for 5 seconds and try to switch on again.

3.5 Hardware troubleshooting

If TC305/TC303 doesn't function properly, we recommend that you send it to us for reparation. Board or module level trouble shooting can be done also by other qualified service personnel. However, reparations by others than Beamex during the warranty period invalidate the warranty.

If you have another functional TC305/TC303, you can relatively easy find the faulty part of the calibrator. Something can also be concluded from the symptoms without replacement parts.

3.5.1 Front assembly

3.5.1.1 Display and keypad board

Fault on the display and keypad board is obvious, if

- * The calibrator functions, but some display segments never show.
- * Display back light or some parts of it never function.
- * Some keys never function. In this case the fault can be on the main processor board or in cabling, too.
- * Some keys stick. The obvious reason is that some dust or liquid has penetrated into the keypad.

If the malfunction of the keys or displays depends on the task that the calibrator is carrying out, the fault is more obviously on the main processor board.

3.5.1.2 Battery pack

If the calibrator can not be used long time enough after recharge, check first that the fault is not in the recharging. After sufficient recharge time disconnect the charger and after a few minutes measure the battery voltage (See Instruction Manual part C, Chapter 3). The reading should be about 100%. If the value is too low, check the charger and the power supply card.

If the batteries can be charged to full charge but the using time is considerably shortened, the obvious reason is faulty battery pack. The battery may also damage so that the calibrator cannot be switched on at all. In such case, remove the calibrator cover and measure the battery voltage. With fully charged battery the voltage should be around 8.5V at room temperature, if the charger has not been connected for 15 minutes and the calibrator is not switched on.

Warning!

Avoid short circuiting the battery terminals, the short circuit current may cause burns, battery damage or even fire. See also warning in the Instruction Manual Part A, Chapter 2.3.

3.5.1.3 Power supply board

The functions on the power supply board include battery charge control and generation of supply voltages. The power supply construction is quite complicated and all you are recommended to do is to measure the output voltages. For the measurements you must connect all cables coming from the power supply card and switch the calibrator on. The most important voltage is marked 'G' on the following figure. If it is about 25.5V, it is obvious that all other voltages are right, too. If your calibrator has the 24V supply option, measure the 24V supply output. If it is right, you can be quite sure that the other voltages are right, too.

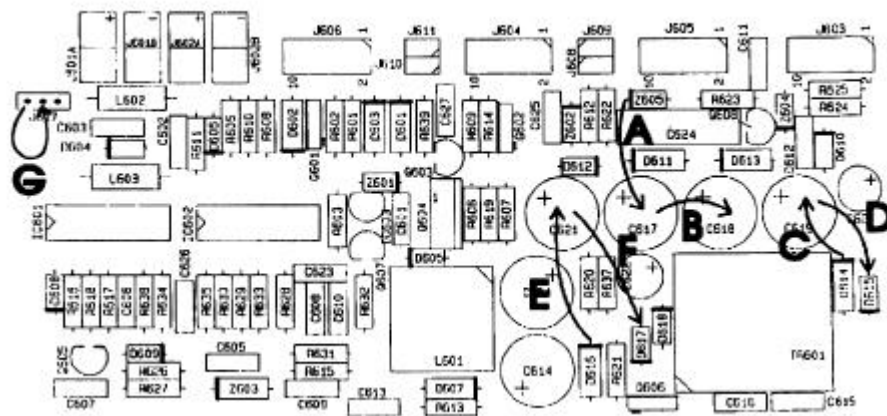

A,B = 15V C...F = 5V G = 25.5V

The calibrator sections A and B should be galvanically isolated from each other. To check this, switch the calibrator off and measure the DC-resistance between the CJ-block minus terminal and the section B black terminal. The value should be more than 10 megaohms. If the resistance is lower, the fault can be in the power supply, in the i/o-assembly, in one of the processor boards or in cabling.

Warning!

Use an ordinary ohm meter, not a high voltage isolation meter. The galvanic isolation between the sections is for functional purposes only.

3.5.2 Analog i/o assembly

The analog i/o assembly consists of three cards, but they should only be replaced as one unit. If one of the cards or some components were replaced, the entire unit should be redefined in the factory, otherwise the required accuracy can not be achieved. On the other hand, all components related to calibration are in the analog i/o assembly. This means that calibration is not required if one analog i/o assembly is transferred from one calibrator to another.

For the communication and calibration security purposes, the calibrator serial number is stored in the EEPROM of the calibrator. It is recommended that the stored serial number is the same as marked on the connection panel. Because the EEPROM circuit is part of the analog i/o assembly, the numbers remain equal if you replace the analog i/o assembly together with the connection panel.

If you replace the three analog cards only, you should change the serial number stored in the EEPROM to the same as marked on the connection panel.

To check the stored serial number of the calibrator as well as the serial number of the analog i/o assembly installed in the calibrator, select the configuration menu entry

```
CONF  
<OTHERS>      (quick select CONF STO)
```

To the prompt

```
C.CODE?  
enter the code  
101 ENT
```

For example the display

```
C.330  
E.10234
```

means that the serial number of the calibrator is 330 and the serial number of the analog i/o assembly is 10234. If the calibrator serial number differs from the one marked on the connection panel, write the displayed numbers on paper and press ESC to exit.

If the calibrator serial number was not the one marked on the connection panel, we recommend you to change the stored number. Tell us the displayed serial numbers for the calibrator and for the analog i/o assembly as well as the serial number marked on the connection panel. We will give you orders, how to change the serial number without losing the installed software options.

If TC305/TC303 doesn't measure or generate/simulate properly, a fault in analog i/o assembly is most obvious. If the only problem is a too large calibration error, try to correct it by calibration (see part C of this manual).

3.5.3 Processor boards

The two processor boards are located on the bottom of the calibrator. The main processor board is on the left side and the temperature processor board is on the right side (front view).

Fault on a processor board may cause many different symptoms. It may stack while showing the 'SELF TEST' prompt, or before showing any special display. It may switch off automatically without any obvious reason or you may even be unable to switch it off at all.

If processor fault occurs only once, it may be result of an extremely strong interference from other electrical circuits or devices. If the fault repeats often, the faulty processor board must be replaced.

If you can't switch the calibrator off, loosen one of the battery wires from the power supply board and loosen the battery charger from the calibrator. When you reconnect the battery wire, you should be able to switch the calibrator on again. When the batteries have been disconnected, TC305/TC303 loses the contents of the read/write memory as well as the real time clock time and date.

3.5.4 Optional 24V supply board

If you have the 24V option and the calibrator works otherwise right, but there is no 24V output, the fault is on the 24V option board (or in cabling).

CALIBRATION

1 GENERAL

The tolerances, nonlinearities and temperature coefficients of the components related to the accuracy of TC305/TC303 are taken into account in the definition calibration at the factory. All the necessary parameters are in the nonvolatile EEPROM memory of each TC305/TC303 calibrator. This information is valid as long as you don't change certain components in the analog part. There are, however, several calibration factors that can change - at least in theory - during the life cycle of the calibrator. Periodical calibration is therefore necessary to maintain the full accuracy of the calibrator.

You can carry out the calibration via the keypad without any internal adjustments. You can also do it with a computer via the RS-232 computer interface. The calibration of the calibrator is made easy for the user. Some highly accurate equipment are, however, necessary for the calibration. If you do not have the necessary equipment, send TC305/TC303 to Beamex for calibration.

2 EQUIPMENT REQUIRED FOR CALIBRATION

For the complete calibration of TC305/TC303 temperature calibrator you need the following equipment:

- 1) DC calibrator, capable to generate the voltages and currents in the following table with the stated accuracy.
- 2) DC meter, capable to measure the generated voltages in the calibration of the resistance simulation.
- 3) Four precision resistors, resistances and accuracies as stated in the following table.
- 4) A good quality thermocouple of type E, J, K or T. We recommend type E because of its high output voltage. The sensor wires should be continuous without extension or plug. The error of the sensor output at the condition where the sensor is in the used temperature reference and the reference junction in 20 to 30°C should be known and taken into account in the calibration.
- 5) An icebath or another known temperature reference. The combined uncertainty of the temperature reference and the thermocouple together should be less than 0.05°C.

You can replace the items 4 and 5 with a small size temperature sensor and measuring device with calibrated accuracy better than 0.05°C. The sensor must be small enough to fit inside the thermocouple connector block. It should not remarkably conduct heat to or from the environment.

Required signals for B-section calibration:

Calibr. point Stable within Uncertainty

45 to 50 V	± 2 mV	± 3 mV
13.5 to 15 V	± 0.5 mV	± 1 mV
3.6 to 4 V	± 0.2 mV	± 0.4 mV
99 to 130 mV	± 5 μ V	± 10 μ V
49 to 60 mA	± 2 μ A	± 5 μ A
19 to 22 mA	± 1 μ A	± 2 μ A

Required signals for calibration of A-section measurements:

<u>Calibr. point</u>	<u>Stable within</u>	<u>Uncertainty</u>
9.9 to 12 V	± 0.5 mV	± 1 mV
3.6 to 4 V	± 0.2 mV	± 0.4 mV
99 to 120 mV	± 5 μ V	± 10 μ V
27 to 30 mV	± 2 μ V	± 3 μ V
49 to 60 mA	± 2 μ A	± 5 μ A
19 to 22 mA	± 1 μ A	± 2 μ A
3600 to 4000 Ω		± 270 m Ω
1170 to 1300 Ω		± 90 m Ω
360 to 400 Ω		± 30 m Ω
144 to 160 Ω		± 15 m Ω

Required equipment for calibration of resistance simulation:

Resistance measuring device:

- * measurement current 1 mA +/- 10%
- * accuracy 0 to 400 ohm: better than 15 mohm
- * accuracy 400 to 4000 ohm: better than 150 mohm

or

Current source 0.9 to 1.1 mA, known with uncertainty ± 30 nA
and voltage measuring device:

- * 0 to 5 V: $R_{in} > 10$ G Ω , accuracy better than 0.001 % of reading

The stated accuracies for the necessary equipment are about three times better than the accuracy specified for TC305/TC303. If the accuracies of the calibration equipment are worse, the calibration period should be shorter. If you, however, are not sure that the calibration equipment has better accuracy than the TC305/TC303 to be recalibrated, send it to Beamex for calibration.

3 PREPARATIONS BEFORE CALIBRATION

The ambient temperature of the calibration environment should be $23^{\circ}\text{C} \pm 2^{\circ}\text{C}$. Check that the required equipment is available. Switch the equipment on in good time to assure the best accuracy. There should be at least 50 % of the battery capacity left in the TC305/TC303. Disconnect the charger at least one hour before the calibration. Switch the calibrator on about one hour before starting the calibration.

Whenever you change the test wiring, wait a couple of minutes allowing the temperature to stabilize. Otherwise there may be extra thermovoltages in the wiring worsening the calibration results.

4 SECTION B MEASUREMENTS

Use the code 3051 in the CONF menu entry OTHERS to start the calibration of the B-section measurements. In order to prevent accidental calibration, TC305/TC303 requests for a security code

S.CODE

?

Start with TC305/TC303 serial number, key in an extra '1' and finally press **□ENT**. For instance to the device with s/n 780, key

7801 ENT

The lower display shows now the measured electrical signal. In case Swi was selected, TC305/TC303 automatically changes to mV-measurement. The upper display prompts

REF?

For each measurement (mV, V, mA) carry out the following steps:

- 1 Select the required measurement (mV, V, mA) with the up arrow key (key SEL[9] is numeric in this mode).
- 2 Connect the required calibration signal to the selected terminals.
- 3 Key in the correct value of the calibration signal and press **□ENT** when the measured value has been stable for more than 10 seconds.

If there were not at least 21 successive readings within certain limits before you pressed **□ENT**, TC305/TC303 flashes:

NOT

STABLE

In this case, make sure that the reading is stable and press **□ENT** again.

If there are more than one calibration point in the following table for the selected measurement, repeat the steps 2 and 3 for each point. Calibrate the points from the highest point to the lowest. Otherwise the error message

RANGES

DIFFER

may flash. In this case, use a bit lower calibration signal or calibrate first the higher point.

The following table shows the required calibration points for each measurement:

<u>Calibr. point</u>	<u>Stable within</u>	<u>Uncertainty</u>
99 to 130 mV	$\pm 5 \mu\text{V}$	$\pm 10 \mu\text{V}$
45 to 50 V	$\pm 2 \text{ mV}$	$\pm 3 \text{ mV}$
13.5 to 15 V	$\pm 0.5 \text{ mV}$	$\pm 1 \text{ mV}$
3.6 to 4 V	$\pm 0.2 \text{ mV}$	$\pm 0.4 \text{ mV}$
49 to 60 mA	$\pm 2 \mu\text{A}$	$\pm 5 \mu\text{A}$
19 to 22 mA	$\pm 1 \mu\text{A}$	$\pm 2 \mu\text{A}$

If the entered true value of the calibration signal does not fit within the range of any calibration point, TC305/TC303 flashes the error message

**BAD
VALUE**

Enter a new value so, that it fits within the limits of one of the points in the table above.

If the measured value differs too much from the entered value, TC305/TC303 only flashes the error message:

**CAL
ERROR**

without altering the calibration. Check that the connected signal is correct and try again.

The calculated calibration factors are now stored temporarily only. If you want to save them permanently, press the key **STO** and to the prompt

**ENT=
SAVE**

press the key **ENT**. Now TC305/TC303 saves the new calibration factors to the EEPROM memory and returns to the basic measure/generate operation. Pressing any other key than **ENT** causes return to the calibration mode.

If you want to exit the calibration mode without saving anything, switch TC305/TC303 off.

5 SECTION A MEASUREMENTS

Turn the MEASURE/GENERATE switch to the position MEASURE.

Use the code 3052 in the CONF menu entry OTHERS to start the calibration of the A-section measurements. In order to prevent accidental calibration, TC305/TC303 requests for a security code

S.CODE

?

Start with TC305/TC303 serial number, key in an extra '2' and finally press **□ENT**. For instance to the device with s/n 780, key

7802 ENT

The upper display shows now the measured electrical signal. The lower display prompts

REF?

For each measurement (mV, V, mA, ohm) carry out the following steps:

- 1 Select the required measurement (mV, V, mA, ohm) with the up arrow key (key SEL[8] is numeric in this mode).
- 2 Connect the required calibration signal to the selected terminals. Use 4-wire connection with resistors.
- 3 Key in the correct value of the calibration signal or resistance and press **□ENT** when the measured value has been stable for more than 10 seconds.

If there were not at least 21 successive readings within certain limits before you pressed **□ENT**, TC305/TC303 flashes

NOT

STABLE

In this case, make sure that the reading is stable and press **□ENT** again.

If there are more than one calibration point in the following table for the selected measurement, repeat the steps 2 and 3 for each point. Calibrate the points from the highest point to the lowest. Otherwise the error message

RANGES

DIFFER

may flash. In this case, use a bit lower calibration signal or calibrate first the higher point.

The following table shows the required calibration points for each measurement:

Calibr. point	Stable within	Uncertainty
99 to 120 mV	$\pm 5 \mu\text{V}$	$\pm 10 \mu\text{V}$
27 to 30 mV	$\pm 2 \mu\text{V}$	$\pm 3 \mu\text{V}$
9.9 to 12 V	$\pm 0.5 \text{ mV}$	$\pm 1 \text{ mV}$
3.6 to 4 V	$\pm 0.2 \text{ mV}$	$\pm 0.4 \text{ mV}$
49 to 60 mA	$\pm 2 \mu\text{A}$	$\pm 5 \mu\text{A}$
19 to 22 mA	$\pm 1 \mu\text{A}$	$\pm 2 \mu\text{A}$
3600 to 4000 Ω		$\pm 270 \text{ m}\Omega$
1170 to 1300 Ω		$\pm 90 \text{ m}\Omega$
360 to 400 Ω		$\pm 30 \text{ m}\Omega$
144 to 160 Ω		$\pm 15 \text{ m}\Omega$

If the entered true value of the calibration signal or resistance does not fit within the range of any calibration point, TC305/TC303 flashes the error message

**BAD
VALUE**

Enter a new value so, that it fits within the limits of one of the points in the table above.

If the measured value differs too much from the entered value, TC305/TC303 only flashes the error message

**CAL
ERROR**

without altering the calibration. Check that the connected signal is correct and try again.

The calculated calibration factors are now stored temporarily only. If you want to save them permanently, press the key **ENT** and to the prompt

**ENT=
SAVE**

press the key **ENT**. Now TC305/TC303 saves the new calibration factors to the EEPROM memory and returns to the basic measure/generate operation. Pressing any other key than **ENT** causes return to the calibration mode.

If you want to exit the calibration mode without saving anything, switch TC305/TC303 off.

6 RESISTANCE SIMULATION

Turn the MEASURE/GENERATE switch to the position GENERATE.

Use the code 3053 in the CONF menu entry OTHERS to start the calibration of resistance simulation. In order to prevent accidental calibration, TC305/TC303 requests for a security code

S.CODE

?

Start with TC305/TC303 serial number, key in an extra '3' and finally press **ENT**. For instance to the device with s/n 780, key

7803 ENT

For measurement of the simulated resistance, use a resistance measurement equipment with measurement current $1\text{ mA} \pm 10\%$. Use four wire connection between the measuring equipment and TC305/TC303 two leftmost ohm terminals. Alternatively you can use separate equipment for current sourcing and voltage measurement. In that case you have to calculate the resistance values from the current and voltage readings. The required test equipment are specified in Chapter 2.

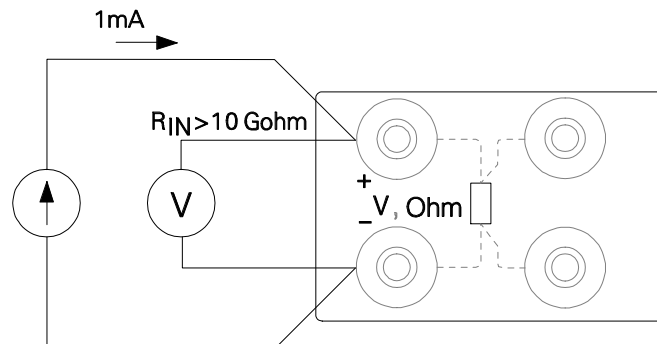

The upper display shows the simulated resistance. The lower display prompts
REF?

The first value to be simulated is around 400 ohms. If the shown value differs from the measured resistance, enter the right resistance value. Now the upper display should show the entered value. Select the next calibration point by pressing the up arrow key. The calibration points are around 400, 10, 10 and 4000 ohms (The value around 10 ohm will be simulated twice with different internal configuration).

Note that the calibration of the 400 ohm point affects all other points. For this reason, if the 400 ohm point needs to be calibrated, it should be done first.

If the entered true value of the measured resistance differs too much from the one calculated by TC305/TC303, TC305/TC303 only flashes the error message

**CAL
ERROR**

without altering the calibration. Check the wiring and the measured/calculated resistance and enter the right value.

The calculated calibration factors are now stored temporarily only. If you want to save them permanently, press the key **□STO** and to the prompt

**ENT=
SAVE**

press the key **□ENT**. Now TC305/TC303 saves the new calibration factors to the EEPROM memory and returns to the basic measure/generate operation. Pressing any other key than **□ENT** causes return to the calibration mode.

If you want to exit the calibration mode without saving anything, switch TC305/TC303 off.

7 INTERNAL REFERENCE JUNCTION COMPENSATION

Turn the MEASURE/GENERATE switch to the position MEASURE.

Use the code 3054 in the CONF menu entry OTHERS to start the calibration of internal reference junction compensation. In order to prevent accidental calibration, TC305/TC303 requests for a security code

S.CODE

?

Start with TC305/TC303 serial number, key in an extra '4' and finally press **ENT**. For instance to the device with s/n 780, key

7804 ENT

Carry out the calibration as explained either in Chapter 7.1 or in Chapter 7.2.

If the measured value differs too much from the entered value, TC305/TC303 only flashes the error message

CAL

ERROR

without altering the calibration. Check the measurement and try again.

The calculated calibration factor is now stored temporarily only. If you want to save it permanently, press the key **STO** and to the prompt

ENT=

SAVE

press the key **ENT**. Now TC305/TC303 saves the new calibration factor to the EEPROM memory and returns to the basic measure/generate operation. Pressing any other key than **ENT** causes return to the calibration mode.

If you want to exit the calibration mode without saving anything, switch TC305/TC303 off.

7.1 Calibration with thermocouple

Use a good quality thermocouple of type E, J, K or T. We recommend the type E because of its high output voltage. Do not use extension wires or plug. Connect the thermocouple to the TC305/TC303 thermocouple connector block. Place the other end of the sensor into the calibration bath (usually an icebath) at least one hour earlier to assure good temperature stabilization. Allow the temperatures in the thermocouple connector block to settle at least five minutes after connection before starting the calibration.

Select the required thermocouple type with the up arrow key (key SENSOR[7] is numeric in this mode). The upper display shows now the measured calibration bath temperature in default temperature units.

The lower display prompts

REF?

Key in the correct temperature, wait until the measurement has been stable over 25 seconds and press **ENT**. If you know the error of the thermocouple in this measurement, you should take it into account.

Example: The measured temperature is 0°C and the reference junction temperature is 26°C. From the calibration of this thermocouple you know, that in this situation it gives the same voltage as a standard thermocouple gives in 0.08°C. In this case you should enter 0.08°C instead of 0°C.

If there were not at least 21 successive readings within certain limits before you pressed **ENT**, TC305/TC303 flashes

**NOT
STABLE**

In this case, make sure that the reading is stable and press **ENT** again.

7.2 Calibration with a thermometer

You can replace the temperature bath and the thermocouple with a small size temperature sensor and indicator. The combined accuracy of the sensor and the indicator should be better than 0.05°C. The sensor must be small enough to fit through a thermocouple plug hole inside the TC305/TC303 thermocouple connector block. It should have a good thermal connection to the gold plated surface of the block and not remarkably conduct heat to or from the environment. Cover the TC305/TC303 thermocouple connector block and the sensor with a good thermal insulation material.

Allow the temperature in the TC305/TC303 thermocouple connector block to settle at least half an hour before the calibration.

Select the thermocouple type B with the up arrow key (key SENSOR[7] is numeric in this mode). Selecting type B is used as a flag telling to TC305/TC303 that you want to calibrate with a thermometer instead of a thermocouple. The upper display shows now the internal temperature of the TC305/TC303 thermocouple connector block in default temperature units.

The lower display prompts

REF?

Key in the correct temperature reading from the external indicator, wait until the TC305/TC303 measurement has been stable over 25 seconds and press **ENT**.

If there were not at least 21 successive readings within certain limits before you pressed **ENT**, TC305/TC303 flashes

**NOT
STABLE**

In this case, make sure that the reading is stable and press **ENT** again.

8 CALIBRATION DATE

TC305/TC303 saves the latest calibration date. There is a separate date for both A- and B-section calibration. If there is no need to change the calibration of a section, you may anyhow want to save the calibration date.

To change the calibration date for the A-section, select the calibration of A-section measurements, resistance simulation or internal reference junction. Escape from the prompt REF? by pressing the key **□STO** and to the prompt

ENT =

SAVE

press the key **□ENT**.

To change the calibration date for the B-section, select the calibration of B-section measurements and proceed as explained above.

Switch the calibrator off and on again before checking the new calibration dates.

9 AUTO CALIBRATION OF GENERATION RANGES

Turn the MEASURE/GENERATE switch to the position GENERATE.

Use the code 3055 in the CONF OTHERS menu to start the auto calibration of mA-, mV- and V-generation. This auto calibration has no effect in the final accuracy of these generations. It does, however, increase the accuracy of ramp function, prevent overshooting in stepping and shorten the settling time. Carry out this whenever you have recalibrated the A-section measurements.

TC305/TC303 wants to be sure that the mA generation terminals are short circuited and the other terminals are open. Check the connections and press **ENT** to the prompt

mA.LOOP
ENT=GO

TC305/TC303 checks the mA loop. In case of fault it exits flashing the message CAL ERROR.

During the auto calibration TC305/TC303 blinks the message

GEN
ACAL

The mV, V and mA arrows show the phase of the process. TC305/TC303 returns automatically to the basic measure/generate operation after about 30 seconds.

10 CALIBRATION PERIOD

Use the code 3056 in the CONF menu entry OTHERS to set the calibration period of TC305/TC303. In order to prevent accidental change, TC305/TC303 requests for a security code

S.CODE

?

Start with TC305/TC303 serial number, key in an extra '6' and finally press **□ENT**. For instance to the device with s/n 780, key

7806 ENT

The factory setting for the calibration period is 6 months. According to your experience and your accuracy requirements, you may want to increase or decrease the time.

TC305/TC303 prompts

PERIOD

on the upper display and shows the current calibration period setting in months on the lower display. If the period is not suitable, alter it by keying in the new value and pressing **□ENT**. Pressing **□ESC** escapes without altering the previous setting.

TC305/TC303 checks the date of the next calibration, when you switch it on. After the recommended calibration date it shows the message

CALIBR

SOON

every time you switch it on. You can use TC305/TC303 normally in spite of the message, if you press **□ESC**. To assure the accuracy, however, you should recalibrate the calibrator soon.

Normally the critical components of TC305/TC303 do not change remarkably within six months. In practice it is possible that one TC305/TC303 calibrator doesn't need any calibration after years of operation. Another unit, however, may need calibration after six months operation. Therefore, we recommend you to use the six months calibration period at the beginning. If you then notice that the small drift of your calibrator enables longer calibration period, you can alter the period.

SERIAL COMMUNICATION

1 GENERAL

The TC305/TC303 computer interface connector uses CMOS/TTL level signals. No handshaking lines are used. Use Beamex RS1 or RS2 interface device to connect TC305/TC303 to the computer serial port. These interface devices convert the signals to the standard RS-232 level. RS1 computer interface makes galvanic connection between TC305/TC303 and the computer. Do not use TC305/TC303 for measurement or generation/simulation purposes, if it is connected to the computer via RS1 interface. If the interface will be used during measurement and/or generation, use the isolated RS2 interface.

Warning!

Never connect RS-232 level signals directly to the TC305/TC303 connector! It may damage the TC305/TC303 internal circuits. Always use RS1 or RS2 interface device between TC305/TC303 and the computer.

Never connect TC305/TC303 to circuits that are in connection to ground if TC305/TC303 is connected to the computer with unisolated interface device (RS1)! Connection may cause ground loops, noise coupling or even circuit damage.

2 TECHNICAL SPECIFICATIONS

The technical specifications of the interface are:

Baud rate:	4800
Parity:	None
Data bits:	8
Stop bits:	1
Flow control:	XON/XOFF host and calibrator
Receive buffer:	256 byte ring buffer
Transmit buffer:	80 byte line buffer
HW error check:	Framing and overrun error
SW error check:	Receive buffer overrun, optional checksum

NUL (ASCII code 0) characters are omitted by TC305/TC303.

2.1 Flow control (XON/XOFF)

TC305/TC303 uses XON (ASCII code 17) and XOFF (ASCII code 19) for flow control. When the receive buffer (256 bytes) fills up to 70% (180 bytes) TC305/TC303 sends an XOFF to the host. When the receive buffer empties to 10% (25 bytes) TC305/TC303 sends an XON to the host. While TC305/TC303 has only 75 bytes free in the receive buffer when it sends XOFF, the host should immediately process the XOFF character and stop sending (i.e. the XON/XOFF processing should be low level coded). We recommend the use of ASYNCH MANAGER (Pascal) or C ASYNCH MANAGER (C or C++ language), both available from BLAISE COMPUTING INC.

2.2 Checksum

The checksum consists of a TAB character (ASCII code 9), and a two digit 8-bit hexadecimal number (A..F in capitals!), which is calculated by

- 1) Adding all the characters in the message including the 'TAB' character from the checksum.
- 2) Forming an 8-bit number.
- 3) Taking the 1's complement (8-bits).

If the checksum received by TC305/TC303 is 'XX' (two capital X-letters, code 88 dec), the checksum will not be verified and it is assumed to be correct.

If necessary, see Appendix C for an example on how to calculate the checksum.

2.3 Acknowledgment (ACK/NAK)

TC305/TC303 uses ACK (ASCII code 6) and NAK (ASCII code 21) acknowledgement control. Acknowledgement can only be used in combination with checksum. When the calibrator has sent the line and respective checksum, it will wait for ACK (acknowledgement) or NAK (negative acknowledgement). On reception of NAK TC305/TC303 will resend the last message, whereas ACK allows TC305/TC303 to send next message. That is: if checksum is invalid send NAK, if checksum is correct send ACK.

2.4 Line terminators (CR/LF)

The terminator(s) sent by TC305/TC303 can be selected with the 'Y' command. There are four alternatives (for more details, see 'Y' and 'S' commands):

Command	Answer
'Y0S'	"Status: 0000 Ok[cr][lf]"
'Y1S'	"Status: 0000 Ok[lf][cr]"
'Y2S'	"Status: 0000 Ok[cr]"
'Y3S'	"Status: 0000 Ok[lf]"

On reception multiple line terminators are omitted, i.e. the three following commands are similar:

"x2[cr]" "x2[cr][lf]" "x2[lf][lf][lf][lf][lf]"

3 COMMANDS

All standard commands consist of one letter and arguments (usually numbers or a question mark). The letters may be in upper or lower case. A command must be completed with all its arguments before the line terminator (CR/LF). There may be more than one command on each line, but the total length of one single command line must not exceed 180 bytes. If 180 characters have been received and there has been no line terminator (CR/LF) TC305/TC303 will discard all characters until a line terminator is received (i.e. the command line is truncated to 180 characters). Note that special commands require to be alone on the command line and cannot be mixed with the ordinary commands.

"u0l0c1x2[cr]"	Ok!
"x0RESET305"	Invalid!

'x0' is performed successfully but then TC305/TC303 does not recognize 'RESET305' as a special command while the special commands need to be alone on the command line. I.e. TC305/TC303 would process the commands x0, R, E, S, E and T305.

The factory settings for the computer interface parameters are shown with an asterisk *) in the following command lists. Factory settings can be recalled via the calibrator keypad. Factory settings for the serial interface only can be recalled with the command 'RESET305'.

3.1 Interface configuration and control

3.1.1 Communication control

These commands control the use of checksum and acknowledgement in the communication. Note that you must use the present checksum mode with the 'C' commands, too. If you do not know the present checksum mode, recall factory settings via the calibrator keyboard or try with and without checksum and acknowledgement to find the present mode. In checksum mode you can replace the checksum with 'XX' as explained in chapter 4.

C0 *)	No checksum, no acknowledgement
C1	Send checksum
C2	Receive checksum
C3	Send and receive checksum
C4	Send checksum, receive acknowledgement
C5	Receive checksum, send acknowledgement
C6	Send and receive checksum and acknowledgement

3.1.2 Line termination

These commands set the line termination codes used by TC305/TC303.

Y0 *)	line termination = CR+LF
Y1	line termination = LF+CR
Y2	line termination = CR only
Y3	line termination = LF only

3.1.3 Control of sent measurement/generation readings

Q	Send measurement/generation readings and stop automatic sending.
Q?	Send interval time.
Q0 *)	Stop automatic sending of readings
Qxxxx.x	Automatically send readings with an interval of xxxx.x seconds (1.0 <= xxxx.x <= 9999.9).

The measurement/generation printout format is partially selectable with the 'O' commands. Note that the display mode settings have no effect on the readings sent to the computer interface, these readings are always in engineering units.

See Appendix B for more information about the printout format.

3.1.4 Use of status codes

S	Status request. After sending the present status TC305/TC303 clears the status.
S0 *)	Never automatically send status
S1	Automatically send status on command error
S2	Always send status for each command processed
S3	Automatically send status on command line error
S4	Always send status for each command line processed

See Appendix A for more information about the status codes.

3.1.5 Formatting of readings

These commands control the formatting of measurement readings sent by TC305/TC303 ('Q' commands).

Overflow options		
O00 *	Use 'Hi OfI'/'Lo OfI'/'CJ low'/'CJ high'/'CJ open' as overflow indicator	
O01	Use abnormal reading (+)10000/ 10000 as overflow indicator (10001 for CJ open)	
O02	Pad with spaces on overflow	
Justify options		Example
O10 *	Right justify	12.34
O11	Left justify	12.34
Sign options		Example
O20 *	No space on sign place nor plus if positive	12.34
O21	No plus if positive	12.34
O22	Always use sign	+12.34

(Options apply to positive numbers, option 20 applies only if option 11 (left justify) is in use)

3.2 Device configuration

3.2.1 A-section (upper display) electrical unit selection

U0	mV
U1	V
U2	mA
U3	Ohm

3.2.2 A-section temperature / electrical mode selection

F0	Electrical mode
F1	Temperature mode; Celsius
F2	Temperature mode; Fahrenheit
F3	Temperature mode; Kelvin

3.2.3 Temperature sensor selection

Thermocouples:

T00 B type sensor
T01 E type sensor
T02 J type sensor
T03 K type sensor
T04 N type sensor
T05 R type sensor
T06 S type sensor
T07 T type sensor

RTD:

T08 Pt100 sensor

Special sensors:

T09 Special sensor S1
T10 Special sensor S2
T11 Special sensor S3

The required electrical unit (mA, mV, V or ohm) must be set before setting the sensor type.

3.2.4 Temperature scale

10 IPTS-68
11 ITS90

3.2.5 CJ-selection

J0	No reference junction compensation
J1	Internal reference junction compensation
J2	External reference junction compensation
J3	Manual reference junction compensation

3.2.6 Generation value setting

Vxxx.xxxx

NOTE! The generated value is always in engineering units.

3.2.7 Emulation of mechanical switch settings

W00	Supply for mA-generation: EXTERNAL
W01	Supply for mA-generation: INTERNAL
W10	measure/generate: GENERATE
W11	measure/generate: MEASURE

NOTE! The 'W' commands require Local OFF status ('Z1' command). When the calibrator is put back to Local ON state, the switch modes will change back to the physical switch settings on the calibrator.

3.2.8 B-section (lower display) electrical unit selection

L0	mV
L1	V
L2	mA
L3	Switch

3.2.9 Local on/off

Z0	Enable keypad and switches (local on). Keypad and switches are automatically enabled, when TC305/TC303 is switched on.
Z1	Disable keyboard (local off). All keys except LIGHT and OFF are disabled.

3.3 Calibration and service

Calibration and service commands are enabled with 'CAL305' and disabled with 'RESET305' or 'K20' or 'CAL305' without answer.

A0	Exit (disable calibration) and discard changes
A1	Exit with save of modified calibration data. Even when nothing was changed, the new calibration date will be saved.
A2	Calibration of B-section measurements
A3	Calibration of A-section measurements
A4	Calibration of ohm simulation
G0	Select 400 ohm calibration point
G1	Select 10 ohm calibration point using lower gain in the amplifier
G2	Select 10 ohm calibration point using higher gain in the amplifier
G3	Select 4000 ohm calibration point
A5	Calibration of internal reference junction compensation
A6	Auto calibration of generation ranges
Pxxx.xxxx	Set calibration point
Bxxxxx	Set calibrator serial number

3.4 Commands for key emulation / inquiry

These commands get or emulate a key press on the calibrator keypad.

K?	Get key press (requires 'Z1' command (local OFF)). TC305/TC303 answers with the key code (same as in the following commands). If the key is for instance SENSOR[7], the answer is ' Key: 00 '. If no key was pressed, the answer is ' No key '.
K00	Emulate SENSOR[7]
K01	Emulate SEL[8]
K02	Emulate SEL[9]
K03	Emulate ESC[OUT]
K04	Emulate LIGHT[ON]
K05	Emulate T/EL[4]
K06	Emulate MODE[5]
K07	Emulate MODE[6]
K08	Emulate STO
K09	Emulate UP
K10	Emulate °C/°F[1]
K11	Emulate 100%[2]
K12	Emulate 100%[3]
K13	Emulate RCL
K14	Emulate DOWN 
K15	Emulate CJ[0]
K16	Emulate 0%[.]
K17	Emulate 0%[+/-]
K18	Emulate CONF[CL]
K19	Emulate FUNC[ENT]
K20	Emulate OFF

3.5 Other standard commands

3.5.1 System details

X0	Send model and calibrator/analog board serial numbers
X1	Send B-section CPU software version number
X2	Send A-section CPU software version number
X3	Send communications interface software version number
X4	Send version comment

3.5.2 Set/get date

D	Send date
Dddmmyyyhhmmss	Set date day,month,year,hour,minute,second

3.5.3 Display message

E[option][position]string[time]
Display a string. Arguments in brackets are optional

Option	B blink area C clear displays
Position	0..5 upper display, 6..11 lower display)
String	"Hello" the string to display
Time	Displaying time in Seconds.Tenths. If Time is omitted or zero, the message will be displayed until a key is pressed. (valid time: 0.1 .. 1000.0 seconds)

Examples:

E"Abcd" Shows the message 'Abcd' on the TC305/TC303 upper display until a key is pressed

EBC"Error"2
Clears the displays and blinks 'Error' on the upper display for two seconds

EC2"UP"EB7"Down"
Shows ' UP ' on the upper display and blinks ' Down ' on the lower display until a key is pressed

If displays are reserved for some important purpose, for example numeric input, TC305/TC303 reports Busy error. In this case, send first ESC-key code ('K03' command) to release the display and then try the 'E' command again.

3.6 Special commands

Special commands must be 'alone' on the command line just after the previous line termination and followed by a line termination:

{previous command[cr][lf]}CAL305[cr][lf]

RESET305	Reset calibrator to power on status and recall factory settings for the serial interface parameters.
CAL305	Enable calibration. When 'CAL305' is received by the calibrator it will send 'Calibrate?'.
Yes	To enable calibration the next command received must be 'Yes'. On reception the calibrator will answer 'Calibration enabled'. I.e. to enable calibration, send: 'CAL305[cr]Yes[cr]' to the calibrator.

Warning!

Improper use of calibration commands may affect the precision of TC305/TC303. Do not recalibrate unless you have the necessary equipment available. Refer to the calibration instructions.

APPENDIXES

APPENDIX A: STATUS CODE / ERROR MESSAGES IN SERIAL COMMUNICATION

Displayed Message	Error Number	Error Code	Status description
<i>RS ERR CODE 1</i>	01	0001h	Invalid command
<i>RS ERR CODE 2</i>	02	0002h	Invalid argument/number of arguments
<i>RS ERR CODE 3</i>	03	0004h	Argument too big
<i>RS ERR CODE 4</i>	04	0008h	Argument too small
<i>RS ERR CODE 5</i>	05	0010h	Invalid number of arguments
<i>RS ERR CODE 6</i>	06	0020h	Command requires local off
<i>(no mess.)</i>	07	0040h	n/a
<i>NOT STABLE</i>	08	0080h	Calibration signal unstable
<i>CAL ERROR</i>	09	0100h	Calibration error
<i>BAD VALUE</i>	10	0200h	Bad calibration value
<i>CAN.NOT CALIBR</i>	11	0400h	Bad calibration temperature
<i>RANGES DIFFER</i>	12	0800h	Calibration ranges differ
<i>RS ERR CODE13</i>	13	1000h	Busy: can not do command right now (retry...)
<i>RS ERR CODE14</i>	14	2000h	Checksum error
<i>RS ERR CODE15</i>	15	4000h	Buffer overflow
<i>RS ERR CODE16</i>	16	8000h	Framing or overrun error

Normally the error code is shown on the calibrator display. Error codes 8 .. 12 are, however, replaced with the respective error messages used when the calibration is made locally via the calibrator keypad.

The shown status codes are used, if only one error has occurred. If several errors occur, the status codes of the errors are ORed. For instance after invalid command (0001h) and checksum error (2000h) the status is 2001h. Requesting the status clears the status code (after sending it).

APPENDIX B: MEASUREMENT PRINTOUT FORMAT

The measurement printout line consists of 44 characters followed by one or two line termination characters as selected with the 'Y' commands. The table on the next page shows the printout format character by character. For clarity reasons spaces are represented here with underline characters ' _ '.

Note that the %-mode settings do not affect the upper nor the lower display readings, their representation remains in engineering units.

Some positions are not currently used, they are reserved for future expansion, and they currently contain spaces.

Examples of printout:

```

M_____ -4.478mV_____ -4.605mV_____ N__
M_____ -0.001mA_____ -4.385mV_____
M_____ Hi_Ofl_C_____ -0.019mA_____ B__25.86I68
G_____ mV_____ -0.020mA_____ N__
G__c__1.002mA_o__0.668SWI_____
  
```

1	2	3	4
---	---	---	---

Position	Description	
1	Mode for A-section:	M = Measure G = Generate/Simulate
2	Supply for mA generation:	I = Internal E = External _ = mA generation not in use
3-4	___ (future expansion)	
5	Switch state on the upper display:	o = open c = closed _ n/a
6-13	Upper display engineering mode reading, formatted according to options set with 'O' command	
14-16	Upper display unit: C__ = Celsius, F__ = Fahrenheit, K__ = Kelvin mV_, V_, mA_, ohm	
17	Switch state on the lower display:	o = open c = closed _ = n/a
18-25	Lower display engineering mode reading, formatted according to options set with 'O' command	
26-28	Lower display unit: mV_, V_, mA_, SWI (switch)	
29-32	____(future expansion)	
33-34	Temperature sensor type: B_, E_, J_, K_, N_, R_, S_, T_, Pt, S1, S2, S3, ___ = n/a	
35-41	Reference junction temperature, formatted according to options set with 'O' command	
42	Reference junction mode:	I = Internal E = External M = Manual N = None _ = n/a
43-44	Temperature scale	68 = IPTS-68 90 = ITS90
45	First line terminator character (CR or LF)	
46	Second line terminator character (LF or CR or none)	

APPENDIX C: ALGORITHMS

Algorithm 1: Calculate checksum (IBM Basic or GW-Basic)

```
10 S$="abcdefgh"           :REM String to calculate checksum
20 A%=0                     :REM Checksum integer
30 S$=S$+CHR$(9)           :REM Add Tab character
40 FOR X=1 TO LEN(S$)       :REM Calculate sum of all
50 A%=A%+ASC(MID$(S$,X,1)) :REM characters in string
60 NEXT                     :REM
70 A%=(A% XOR 255) AND 255  :REM 1's complement and mask 8 bits
80 S$=S$+HEX$(INT(A%/16))  :REM Add checksum (first character)
90 S$=S$+HEX$(A% MOD 16)   :REM Add checksum (second character)
```

APPENDIX D: TC305/TC303 RS-232 SAVEABLE OPTIONS

The following options may be saved/restored along with the other options:

- Acknowledgment w checksum,
- Output formatting,
- Automatic send interval,
- Status message send and
- Line terminator options.

Like the other options these can be set to their default state at power-on or they can be left intact (at their previous state).