

Standard reference resistor Model 5685 and 5695

Applications

- Primary standards for voltage and resistance in calibration laboratories worldwide
- Calibration reference for resistance and temperature bridges, such as ohmmeters and AC or DC temperature bridges

Special features

- High accuracy
- Excellent long-term stability
- Low temperature coefficient
- Rugged stainless steel construction



Standard reference resistor, model 5685, with 10 Ω

Description

This model is available in two series: 5695 (reference resistor) and 5685 (standard reference resistor). The 5695 series of 4-wire reference resistors offer high accuracy and stability at an economic cost. Designed specifically, for use as a comparison standard for AC thermometry resistance bridges, the 5695 series may also be used in electrical standards laboratories.

In addition to standard fixed values, resistors can be supplied in any value between 1 and 1,000 Ω . Typical applications for the 5695 series are as transfer standards or reference source in temperature calibration or electrical standards laboratories.

The 5685 series is made from a specially selected alloy having a low temperature coefficient mounted in a strain-free manner on formers made from a material of low dielectric loss but of high mechanical stability.

Prolonged heat treatment of the elements ensures long-term stability and low temperature coefficient of resistance. The elements are hermetically sealed in stainless steel containers and filled with dry oil Castrol WOM 14..

Specifications

Reference resistor, model 5695	
Resistance value	1, 10, 25, 100, 300, 400, 500, 1.000 and 10.000 Ω others on request
Tolerance	± 10 ppm
Long-term stability	< ± 5 ppm per year
Temperature coefficient	< 1 ppm per $^{\circ}\text{C}$
Frequency dependence	< 1 ppm up to 400 Hz
Permissible ambient conditions	
Working temperature	20 $^{\circ}\text{C}$ [68 $^{\circ}\text{F}$]
Operating temperature	15 ... 40 $^{\circ}\text{C}$ [59 ... 104 $^{\circ}\text{F}$]
Case	
Dimensions	$\varnothing = 76$ mm, height 114 mm [$\varnothing = 2.99$ in, height 4.49 in]
Weight	0.5 kg [1.1 lbs]

Standard reference resistor, model 5685	
Resistance value	10, 25, 100, 400 and 1,000 Ω others on request
Tolerance	± 10 ppm
Long-term stability	2 ppm per year (HS version 0.5 ppm per year) ¹⁾
Temperature coefficient	2 ppm per $^{\circ}\text{C}$ (HS version 0.5 ppm per $^{\circ}\text{C}$)
Frequency dependence	1 ppm up to 1,592 Hz
Permissible ambient conditions	
Working temperature	20 $^{\circ}\text{C}$ [68 $^{\circ}\text{F}$]
Operating temperature	15 ... 40 $^{\circ}\text{C}$ [59 ... 104 $^{\circ}\text{F}$]
Case	
Dimensions	$\varnothing = 76$ mm, height 114 mm [$\varnothing = 2.99$ in, height 4.49 in]
Weight	0.7 kg [1.5 lbs]

1) No HS version is available for the resistance values 1 k Ω

Certificates

Certificate	
Calibration for model 5695	Standard: without Option: UKAS calibration certificate
Calibration for model 5685	Standard: without Option: UKAS calibration certificate
Recommended recalibration interval	1 year (dependent on conditions of use)

Connections of the reference resistor, model 5695

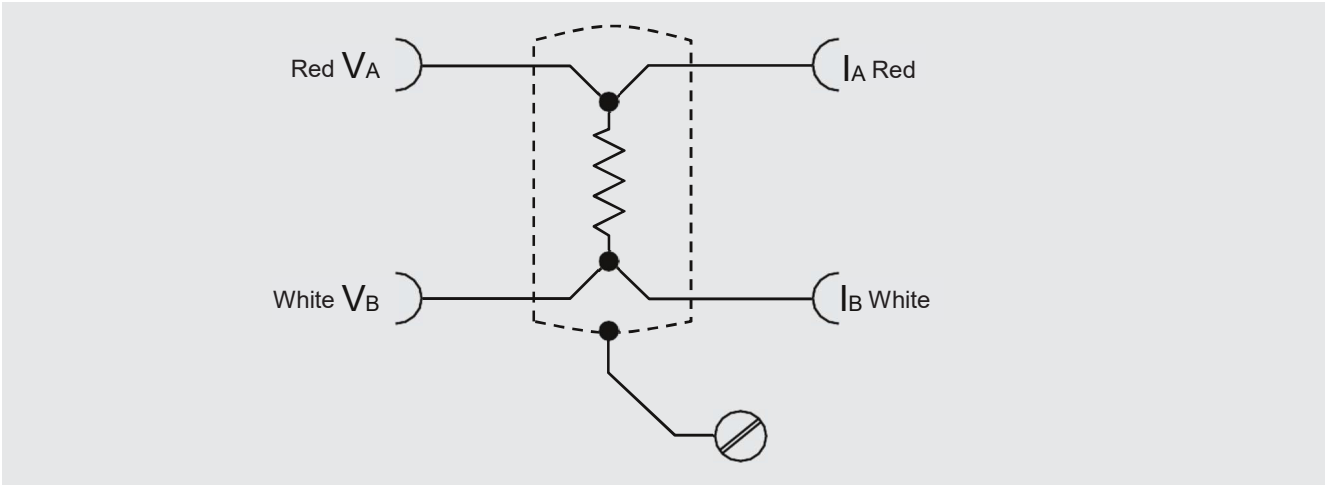

Model 5695 reference resistor with 100 Ω



Model 5695 reference resistor with different resistance range

Standard reference resistor, model 5685

The 4-pin standard reference resistors comply with the highest specification and are suitable for DC or AC use up to frequencies of several kHz. The range available now extends from 1 ... 1,000 Ω .

The resistors are made from a specially selected alloy having a low temperature coefficient and are mounted in a strain-free manner on formers made from material of low dielectric loss but of high mechanical stability. All the internal connections are welded for strength and a specially developed aging technique is used to ensure the long-term stability and low temperature coefficient of resistance. The elements are hermetically sealed in oil-filled stainless steel enclosures.

Provision is made for inserting a thermometer to monitor temperature but best performance is achieved when used in an oil bath which is temperature controlled.

Maximum dissipation for the standard reference resistor is 1 W but the highest performance will be obtained with a dissipation of around 10 mW which is the ideal working condition. No harm will occur if the dissipation is increased to 1 W but self-heating will take effect after a few minutes.

Selected high specification (HS)

During their manufacture some resistive elements exhibit characteristics that show that with substantially increased processing time, they will produce standards with stability and temperature coefficients superior to those specified for the normal product. The standard reference resistors that can be produced from these elements are offered as versions "high specification".

Background information

The design of these AC/DC standard reference resistors is based on the collaboration with the UK national physical laboratory.

The design originated with F. J. Wilkins whose name the instruments still bear to this day. Wilkins resistors are ideally suited for producing a most temperature-stable standard reference resistor with minimum long-term drift, which is suited for use with both direct and alternating current.

Since the introduction of these standard reference resistors they have been adopted by many major industrial companies as their primary resistance reference standards. Information obtained from laboratories over the past twenty-five years indicate their exceptional high specification. With monitored examples exhibiting stabilities within 1 ppm over a period of ten years.



Standard reference resistor, model 5685

Scope of delivery

- Model 5695 & 5865 standard reference resistor according to Specifications

Option

- UKAS calibration of fixed resistor

Accessories

- Model 5695T-terminal adapter for connecting 5695 resistors to BNC (2 per pack)
- Thermal case for 5648 resistors, at a fixed temperature of 36 °C [97 °F]

Note :-(This enclosure has been specially designed to accommodate a single precision resistor of the following types: 5685 or 5695 enabling improved stability when used in a non-temperature-controlled environment. These enclosures are factory set at 36°C, However, they can be supplied to operate at other temperatures.)



Thermal case for 5648 resistors, at a fixed temperature of 36 °C [97 °F]



Tinsley Instrumentation Ltd
1 Warner Drive
Springwood Industrial Estate
Braintree, Essex
CM7 2YW

Tel: 01376 335271
E-mail: info@tinsley.co.uk

www.tinsley.co.uk