

EVALUATION BOARD OVERVIEW

This document explains the design and setup of the AD1940 SigmaDSP evaluation board.

The EVAL-AD1940AZ provides a full range of analog and digital inputs and outputs to and from the AD1940. The SigmaDSP can connect to analog I/O signals through the AD1939 codec and AD1974 ADC. Digital I/O connections are available in both S/PDIF and 3-wire serial data formats. The DSP is controlled by Analog Devices' SigmaStudio™ software, which interfaces to the evaluation boards with a USB cable via the EVAL-ADUSB2EBZ add-on board, also known as the USBi. Power is distributed by a single DC supply, which is regulated to the necessary voltages on the board. The PCB is an 7" × 5" 4-layer design with split analog and digital power and ground planes on the two inner layers.

The AD1940 evaluation board should be used for AD1941 evaluation. There is no AD1941 evaluation board.

PACKAGE CONTENTS

The EVAL-AD1940AZ package contains these items:

- AD1940 evaluation board
- EVAL-ADUSB2EBZ (USBi) communications adapter
- 6V DC power supply with standard US plug
- USB cable with mini-B plug
- Evaluation board/software quick-start guide
- SigmaStudio software

OTHER SUPPORTING DOCUMENTATION

AD1940/AD1941 datasheet

AD1939 datasheet

AD1974 datasheet

SigmaStudio Help (included in the software installation)

AN-1006: Using the EVAL-ADUSB2EBZ

FUNCTIONAL BLOCK DIAGRAM

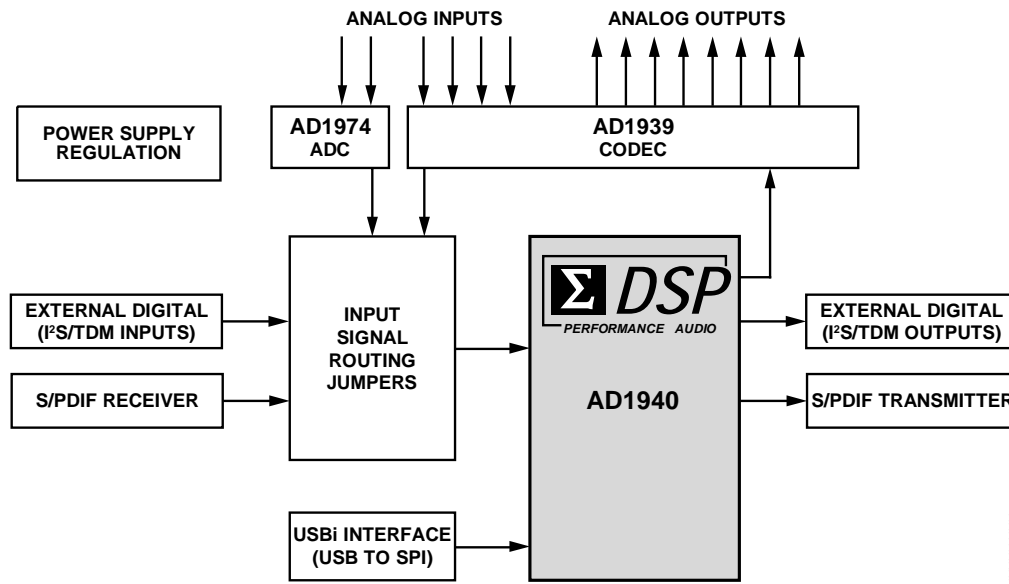

Figure 1. Functional Block Diagram

Rev. PrA

Information furnished by Analog Devices is believed to be accurate and reliable. However, no responsibility is assumed by Analog Devices for its use, nor for any infringements of patents or other rights of third parties that may result from its use. Specifications subject to change without notice. No license is granted by implication or otherwise under any patent or patent rights of Analog Devices. Trademarks and registered trademarks are the property of their respective owners.

BOARD LAYOUT BLOCK DIAGRAM

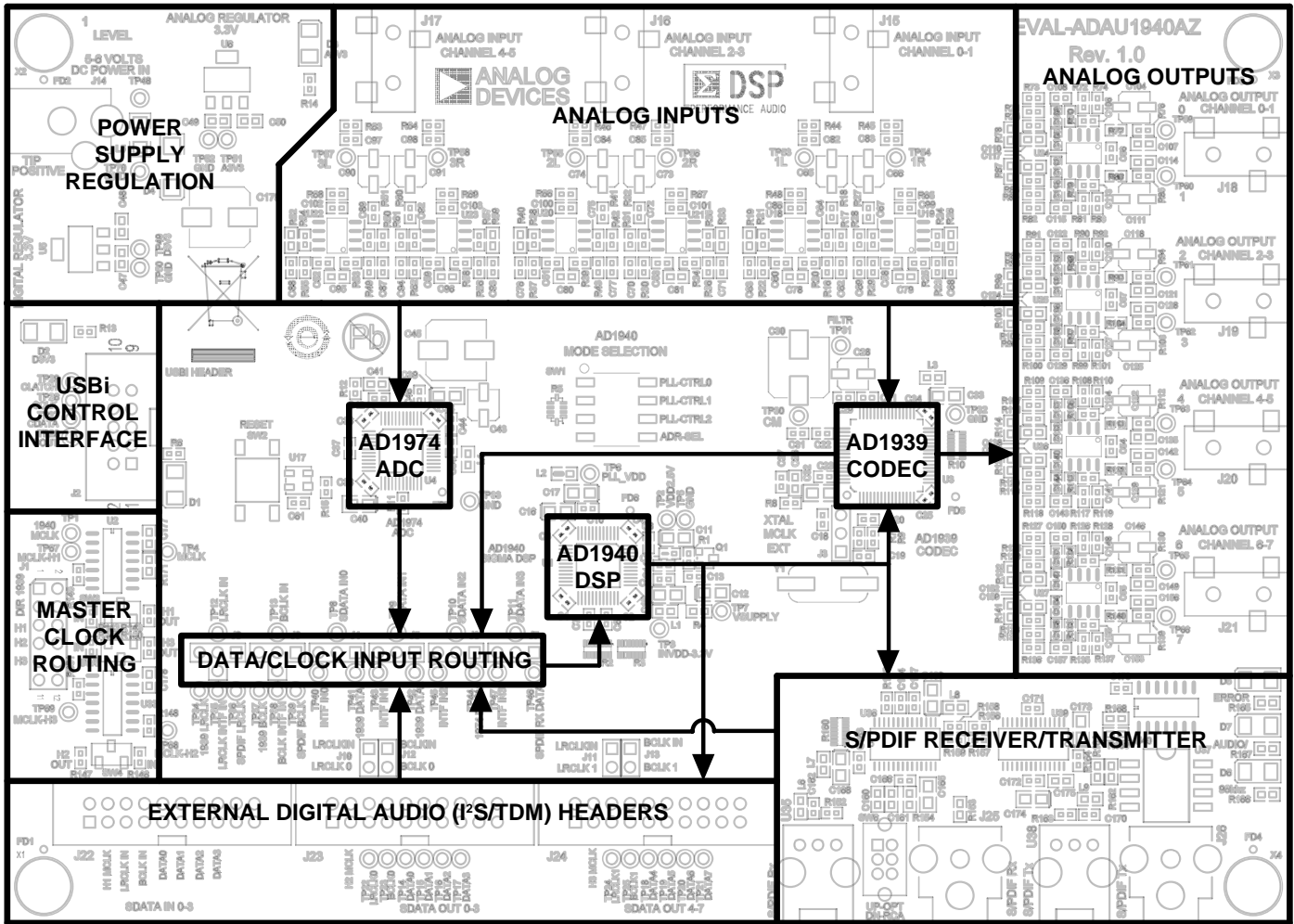

Figure 2. Board Layout Block Diagram

TABLE OF CONTENTS

Evaluation Board Overview	1	Clocking the Evaluation Board	7
Package Contents	1	Input Routing	8
Other Supporting Documentation	1	Analog Audio Inputs	8
Functional Block Diagram	1	External Digital Audio (I ² S/TDM) Inputs	9
Board Layout Block Diagram	2	S/PDIF Receiver	9
Table of Contents.....	3	Output Routing	10
Revision History	3	Analog Audio Outputs	10
Setting Up the Evaluation Board.....	4	External Digital Audio (I ² S/TDM) Outputs.....	10
SigmaStudio Software Installation.....	4	S/PDIF Transmitter.....	10
Powering the board.....	4	Example Configurations	11
Hardware Setup - USBi.....	4	Board Schematics.....	15
Connecting the audio cables.....	4	Board Silkscreen and Parts Placement.....	25
Switch and Jumper settings.....	4	Bill of Materials	26
Your First SigmaStudio Project – EQ and Volume Control	5	Ordering Guide	29
Using the Evaluation Board	7	Ordering Guide	29
AD1940 SigmaDSP	7	ESD Caution	29
Power	7		

SETTING UP THE EVALUATION BOARD

SIGMASTUDIO SOFTWARE INSTALLATION

1. Open the provided .zip file and extract the files to your PC. Alternately, insert the SigmaStudio CD into the computer's optical drive and browse the CD to the SigmaStudio folder.
2. Install Microsoft .NET Framework ver2.0, if you do not already have it installed. (Do this by double-clicking dotnetfx.exe)
3. Install SigmaStudio by double-clicking setup.exe, and following the prompts. A computer restart is not required.

POWERING THE BOARD

The board is powered by the included 6V DC power supply, which should be connected to power jack J14. The power indicator LEDs D3 and D2 should be lit.

HARDWARE SETUP - USBI

4. Plug the USBi into the PC's USB port using the included mini USB cable. Plug in the USBi into the control port J2 on the eval board (marked yellow on Figure 1).
5. Connect the USB cable to your computer, and to the USBi.
6. When prompted for drivers:
 - Choose "Install from a list or a specific location."
 - Choose "Search for the best driver in these locations."

- Check the box for "Include this location in the search."
- The USBi driver is located in C:\Program Files\Analog Devices Inc\Sigma Studio\USB drivers, click Next.
- If prompted to choose driver, select CyUSB.sys
- In XP click Continue Anyway if you are prompted saying the software hasn't passed Windows Logo testing.

CONNECTING THE AUDIO CABLES

For this example, we will set up the board to have stereo analog inputs and stereo analog outputs.

7. Connect the audio source to the ANALOG INPUT CHANNEL 0-1 jack J15 (marked blue in Figure 1) on the top of the board, using a 1/8" cable.
8. Connect the ANALOG OUTPUT CHANNEL 0-1 jack J18 (marked green in Figure 1) to your active speakers or headphones.

SWITCH AND JUMPER SETTINGS

In order to configure the board for stereo analog in and out, make sure the switches and jumpers are set as indicated in Figure 3.

A black rectangle indicates a connected jumper or switch position.

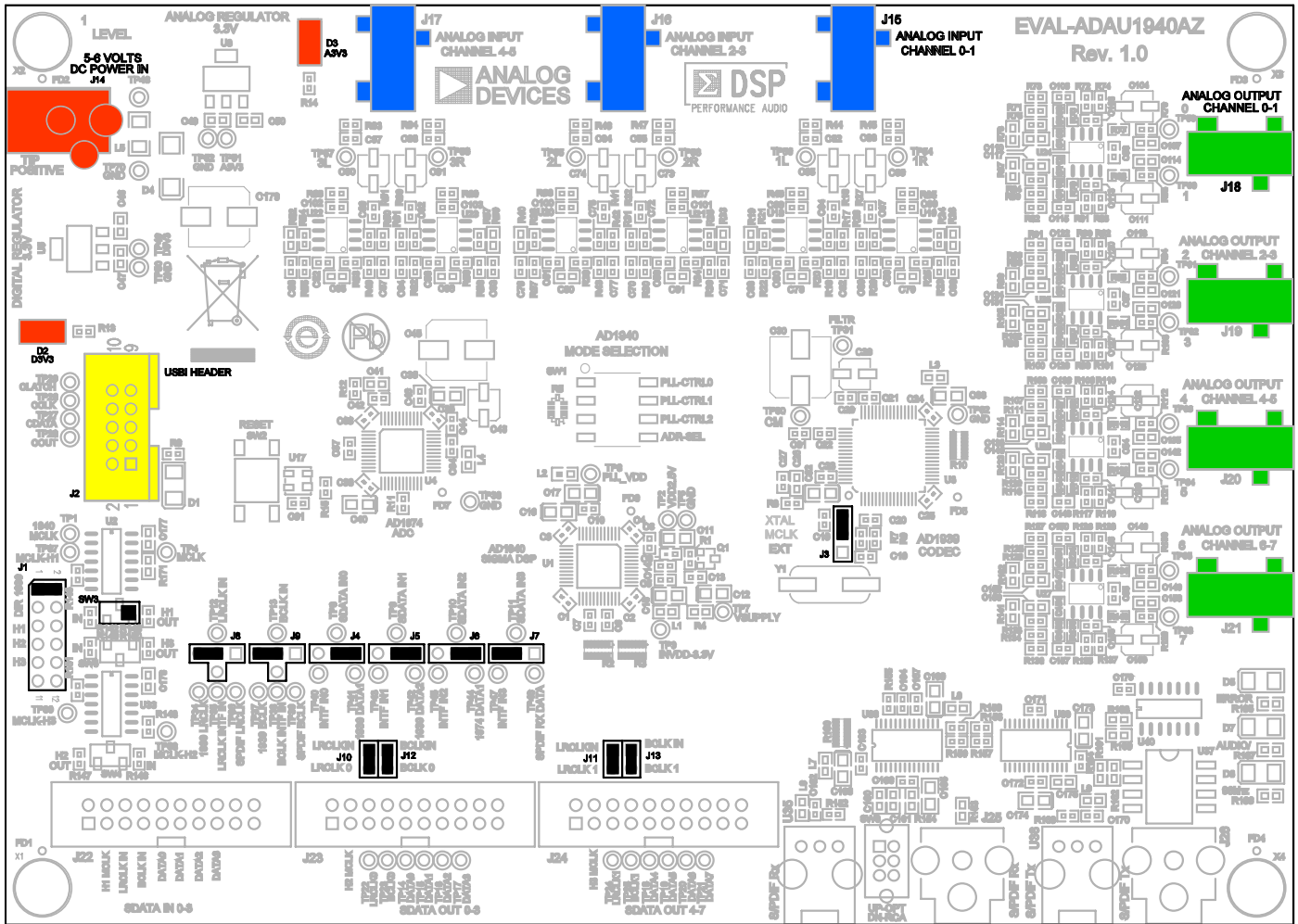

Figure 3. Evaluation Board Default Setup and Configuration

YOUR FIRST SIGMASTUDIO PROJECT – EQ AND VOLUME CONTROL

1. Create a new project. The Hardware Configuration Tab will be open.
2. Drag an AD1940 and a USBi cell into the blank white space.
3. Connect the USBi cell to the AD1940 cell by clicking and dragging from the top blue output pin to the green input pin.

Your screen should now look something like Figure 4.

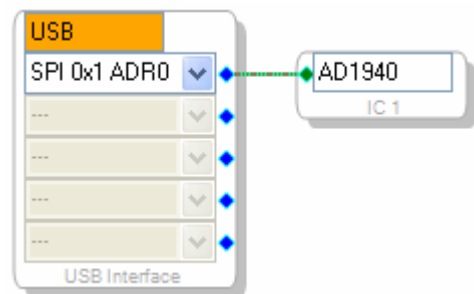

Figure 4. Hardware Configuration Tab

4. Click on the Schematic tab at the top of the screen.
5. In the cell Toolbox expand the IO → Input. Click&Drag an Input cell to the work area.
6. Similarly, expand Filters → Second Order → Double Precision → 2 Ch and click&drag Medium Size Eq
7. Right click the General (2nd Order) cell labeled Gen Filter1, click Grow Algorithm → 1.2 Channel – Double

Precision → 4. This creates a five band EQ. Each band's general filter settings can be modified by clicking the blue boxes on the cell.

8. Expand Volume Controls → Adjustable Gain → Shared Slider → Clickless SW Slew and click&drag Single slew

9. Expand the IO → Output. Click&Drag two Output cells

10. Connect all the cells as depicted in Figure 3.

11. Make sure your board is powered and connected to the PC. Click the Link-Compile-Download button in SigmaStudio.

12. If the project compiled without error you will be in Ready-Download mode.

Your screen should now look something like Figure 5.

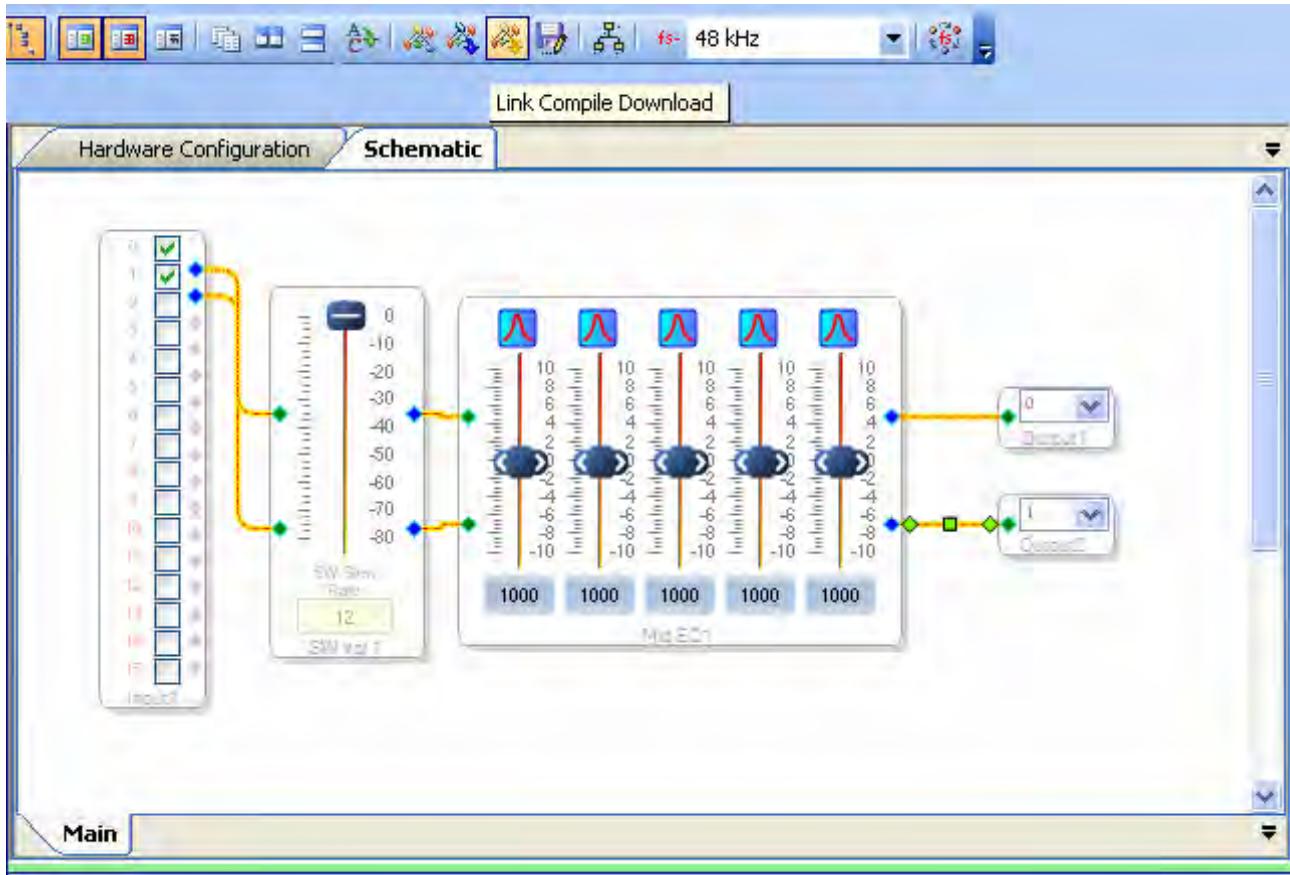

Figure 5. Schematic Tab Full Design

13. Start your audio source playing, and you should hear audio. You can now move the volume control and filter sliders and hear the effect on the output audio in real time.

The online documentation contains more tutorials and detailed information about every cell available.

USING THE EVALUATION BOARD

AD1940 SIGMADSP

The AD1940 is a complete 28-bit, single-chip, multi-channel audio SigmaDSP™ for equalization, multiband dynamic processing, delay compensation, speaker compensation, and image enhancement. These algorithms can be used to compensate for the real world limitations of speakers, amplifiers, and listening environments, resulting in a dramatic improvement of perceived audio quality.

The signal processing used in the AD1940 is comparable to that found in high end studio equipment. Most of the processing is done in full, 56-bit double-precision mode, resulting in very good, low level signal performance and the absence of limit cycles or idle tones. The dynamics processor uses a sophisticated, multiple-breakpoint algorithm often found in high end broadcast compressors.

The AD1940 is a fully programmable DSP. Easy to use software allows the user to graphically configure a custom signal processing flow using blocks such as biquad filters, dynamics processors, and surround sound processors. An extensive control port allows click-free parameter updates, along with readback capability from any point in the algorithm flow.

The AD1940’s digital input and output ports allow a glueless connection to ADCs and DACs by multiple, 2-channel serial data streams or TDM data streams. When in TDM mode, the AD1940/AD1941 can input 8 or 16 channels of serial data, and can output 8 or 16 channels of serial data. The input and output port configurations can be individually set. The AD1940 is controlled by a 4-wire SPI® port.

The EVAL-AD1940AZ should be used to evaluate both the AD1940 and the AD1941, which is equivalent to the AD1940 except for its I²C control interface.

POWER

The evaluation board uses two ADP3339 low-dropout voltage regulators to generate the 3.3 V analog and digital supplies. The current consumption of the board is approximately 500 mA at a maximum.

The regulators’ inputs should be supplied with +5 to +6 V DC power on connector J14. The power supply should have a female cord plug with a 2.1 mm inner diameter, 5.5 mm outer diameter, and 9.5 mm length. The polarization should be positive-center.

A lab supply can also be used to power the board, and should be connected across test points TP48 (VIN+) and TP70 (GND).

CLOCKING THE EVALUATION BOARD

The EVAL-AD1940AZ requires a master clock (MCLK) to operate. The master clock can be supplied from a variety of

sources, and is used to clock the AD1940 DSP, AD1974 ADCs, AD1939 ADCs/DACs, External Digital Audio Interfaces, and the S/PDIF Transmitter.

In most common board configurations, MCLK will be generated by the on-board AD1939. The AD1939 has an internal oscillator that drives a 12.288 MHz crystal to produce a 12.288 MHz master clock suitable for 48 kHz, 96 kHz, and 192 kHz processing applications.

For configurations utilizing the S/PDIF receiver, MCLK must be supplied to the system by the recovered MCLK of the S/PDIF stream. This recovered MCLK has a frequency 256 times the sample rate of the S/PDIF data.

A master clock can also be supplied from an external (off-board) source on the digital audio interface headers J22, J23, and J24. The corresponding MCLK direction switch should be set to IN or OUT as required.

A description of the jumpers used to route MCLK is given in Table 1. Examples of common MCLK configurations are given in the Example Configurations section of this document and in Figure 6.

Table 1. Master Clock Routing

Component	Function
J1	Select MCLK Source/Destination
J3	Enable AD1939 Crystal Oscillator Circuit
SW3	Set direction of MCLK on H1 (J22)
SW4	Set direction of MCLK on H2 (J23)
SW5	Set direction of MCLK on H3 (J24)

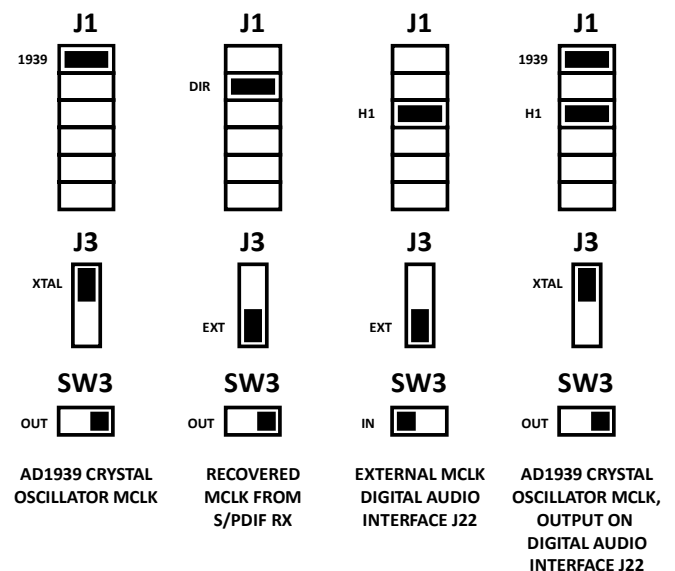

Figure 6. Example Master Clock Routing Settings

The AD1940 must be set up to properly receive MCLK as an input to its PLL. The board will most often be used with a 12.288 MHz master clock, which is equivalent to 256×F_s, with

$F_s = 48$ kHz. In order to set up the AD1940 PLL in $256 \times F_s$ mode, switch SW1 must be set up as shown in .

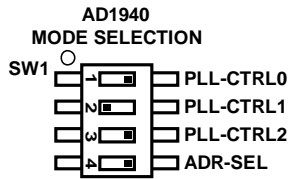

Figure 7. PLL Mode Selection for 12.288 MHz Master Clock

A description of all possible PLL settings is shown in , with 0 corresponding to setting the switch to the right, a 1 corresponding to setting the switch to the left, and “don’t care” represented as an “X.”

Table 2. PLL Settings

PLL Mode	PLL-CTRL0 SW1-1	PLL-CTRL1 SW1-2	PLL-CTRL2 SW1-3
$64 \times f_s$	0	0	0
$256 \times f_s$	0	1	0
$384 \times f_s$	X	X	1
$512 \times f_s$	1	0	0
Bypass	1	1	0

The ADR-SEL switch (SW1-4) determines the SPI address of the AD1940. The default is 0 (switch to the right).

INPUT ROUTING

Audio data is routed to the AD1940 via four jumpers: J4, J5, J6, and J7. A description of these jumpers is in Table 3.

Table 3. SDATA_INx Routing

Component	Function
J4	Select data to input to AD1940 – SDATA_IN0
J5	Select data to input to AD1940 – SDATA_IN1
J6	Select data to input to AD1940 – SDATA_IN2
J7	Select data to input to AD1940 – SDATA_IN3

Input clocks are configured via two jumpers: J8 and J9. A description of these jumpers is in Table 4.

Table 4. LRCLK_IN/BCLK_IN Routing

Component	Function
J8	Select frame clock source for AD1940 serial input ports
J9	Select bit clock source for AD1940 serial input ports

The AD1940 serial input ports are always configured as slaves, so clocks must always be supplied from another source in order for them to function.

ANALOG AUDIO INPUTS

The EVAL-AD1940AZ has three stereo 1/8’ input jacks, allowing for a total of 6 channels of analog audio input. Input channels 0-3 are routed to the AD1939 ADCs and input channels 4-5 are routed to the AD1974 ADCs. In order to input

the converted audio data to the AD1940 DSP, it must be routed appropriately using the audio data routing jumpers.

Proper configuration for inputting all analog audio to the DSP is shown in Figure 8. Note that it is not necessary to use all analog audio inputs simultaneously, and the jumpers can be set in any desired configuration to allow for flexibility in routing a combination of analog, digital, and S/PDIF inputs.

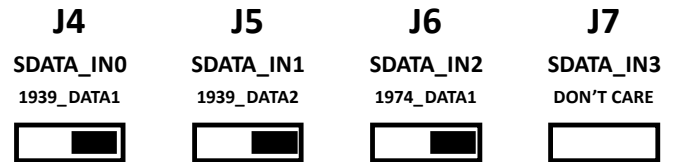

Figure 8. Input Routing Jumpers - Analog Configuration

In an analog input configuration the AD1939 will most commonly be used as the source for LRCLK and BCLK signals. To route this signals to the AD1940’s LRCLK_IN and BCLK_IN pins, configure the jumpers J8 and J9 as shown in Figure 9.

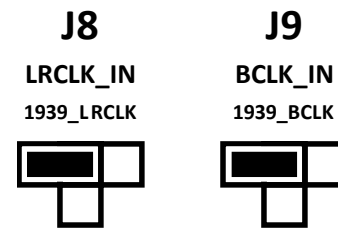

Figure 9. LRCLK_IN/BCLK_IN Routing Jumpers - Analog Configuration

With the jumpers configured as shown in Figure 8 and Figure 9, the analog input signals will appear in SigmaStudio as input channels 0-5, as shown in Figure 10.

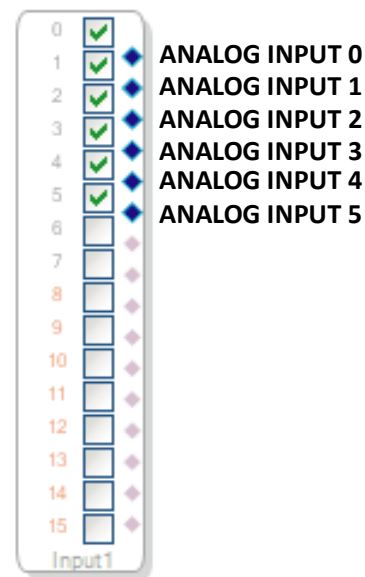

Figure 10. Analog Inputs in SigmaStudio

EXTERNAL DIGITAL AUDIO (I²S/TDM) INPUTS

The EVAL-AD1940AZ has a digital interface input header (J22) with connections for MCLK, LRCLK, BCLK, and four serial data lines, allowing for a total of 8 channels of serial audio input (I²S, right-justified, or left-justified) or up to 16 channels when TDM modes are used. In order to input the audio data to the AD1940 DSP, it must be routed appropriately using the audio data routing jumpers.

Proper configuration for inputting all I²S/TDM audio to the DSP is shown in Figure 11.

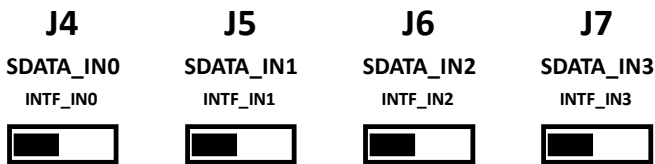

Figure 11. Input Routing Jumpers - I²S/TDM Configuration

When data is supplied on the digital interface input header, there are two options for LRCLK and BCLK routing. First, the AD1939 can be the clock master. This configuration is shown in Figure 12.

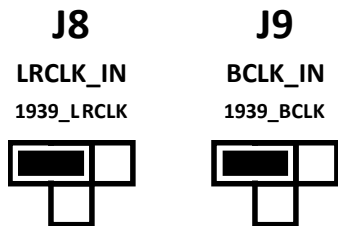

Figure 12. LRCLK_IN/BCLK_IN Routing Jumpers - I²S/TDM Configuration - AD1939 Master

Alternatively, the LRCLK and BCLK signals can be taken from an external source over the LRCLK_IN and BCLK_IN pins of the digital interface input header J22. This configuration is shown in Figure 13.

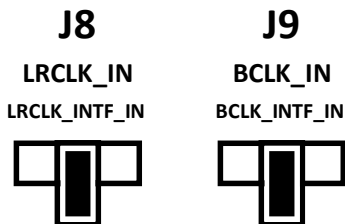

Figure 13. LRCLK_IN/BCLK_IN Routing Jumpers - I²S/TDM Configuration - External Master

With the jumpers configured as shown in Figure 12 and Figure 13, the external I²S input signals will appear in SigmaStudio as input channels 0-7, as shown in Figure 14.

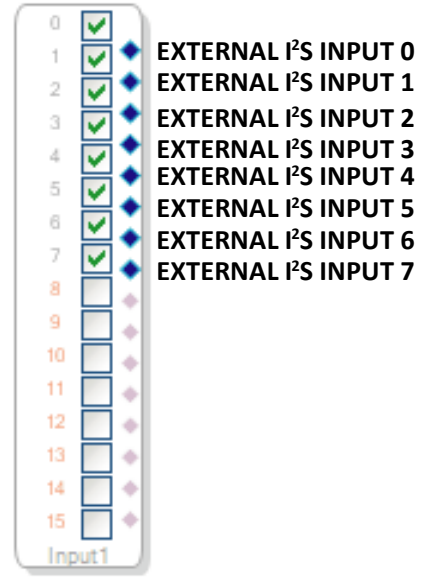

Figure 14. I²S Inputs in SigmaStudio

If the input serial ports are configured in TDM modes (allowing for up to 16 channels), the input channels will appear in SigmaStudio as input channels 0-15, as shown in Figure 15.

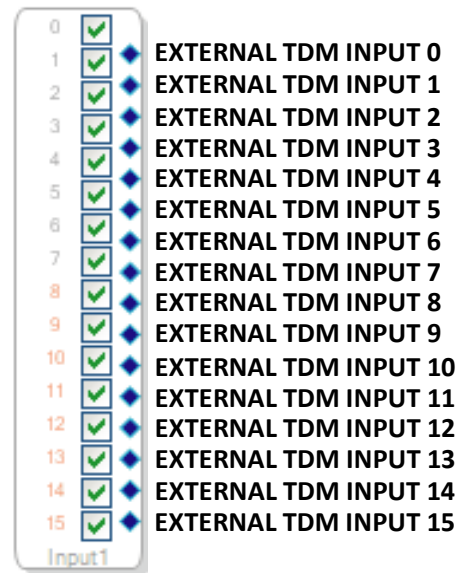

Figure 15. TDM Inputs in SigmaStudio

S/PDIF RECEIVER

The EVAL-AD1940AZ has an S/PDIF receiver with both optical and coaxial connections, allowing for a total of 2 channels of S/PDIF audio to be input to the AD1940. In order to input the audio data to the AD1940 DSP, it must be routed appropriately using the audio data routing jumpers.

Proper configuration for inputting all S/PDIF audio to the DSP is shown in Figure 16.

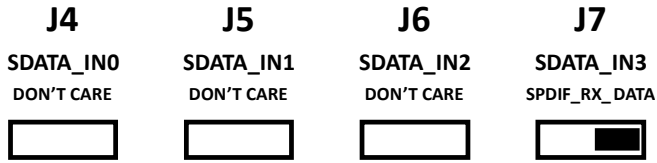

Figure 16. Input Routing Jumpers -S/PDIF Configuration

Because the S/PDIF receiver is always a clock master to the AD1940, the LRCLK_IN and BCLK_IN lines must be connected to the S/PDIF receiver as shown in Figure 17.

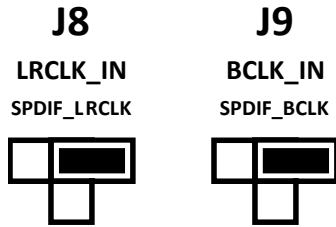

Figure 17. LRCLK_IN/BCLK_IN Routing Jumpers - S/PDIF Configuration

The master clock must also be provided from the S/PDIF receiver. For proper operation, J1 should have a jumper on “DIR” and J3 should be set to “EXT.”

The S/PDIF receiver can only input data from one connector at a time. To select the optical connector, set switch SW6 in the up position. To select the coaxial electrical connector, set switch SW6 in the down position.

With the jumpers configured as shown in Figure 16 and Figure 17, the S/PDIF inputs will appear in SigmaStudio as shown in Figure 18.

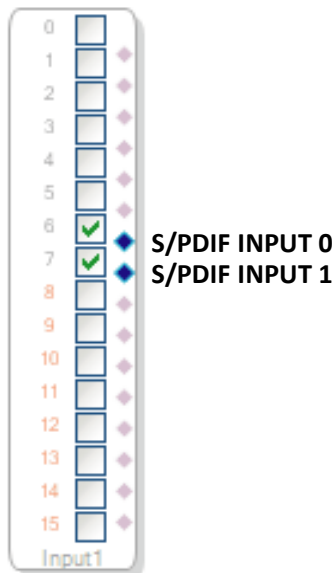

Figure 18. S/PDIF Inputs in SigmaStudio

OUTPUT ROUTING

The AD1940 serial output ports are always connected to the DACs, digital audio output headers, and S/PDIF transmitter. These data signals do not require any jumpers or switches to be output properly. The AD1940 serial output ports can be configured as either masters or slaves. If the AD1940’s serial output ports are configured as masters, then jumpers J10, J11, J12 and J13 can be left disconnected. If the AD1940’s serial output ports are configured as slaves, then jumpers J10, J11, J12 and J13 must be connected in order to output data. The functionality of these jumpers is described in Table 5.

Table 5. Output Clock Routing

Component	Function
J10	Connect LRCLK_OUT0 to LRCLK_IN. Must be connected if serial output channels 0-7 are configured as slaves and not externally clocked.
J11	Connect BCLK_OUT0 to BCLK_IN. Must be connected if serial output channels 0-7 are configured as slaves and not externally clocked.
J12	Connect LRCLK_OUT1 to LRCLK_IN. Must be connected if serial output channels 8-15 are configured as slaves and not externally clocked.
J13	Connect BCLK_OUT1 to LRCLK_IN. Must be connected if serial output channels 8-15 are configured as slaves and not externally clocked.

ANALOG AUDIO OUTPUTS

The EVAL-AD1940AZ has four stereo 1/8’ input jacks, allowing for a total of 8 channels of analog audio output. Output channels 0-7 are routed to the AD1939 DACs. The analog outputs are hardwired to the AD1940’s serial output ports and are always active.

The analog outputs 0-7 correspond to outputs 0-7 in SigmaStudio.

EXTERNAL DIGITAL AUDIO (I²S/TDM) OUTPUTS

The EVAL-AD1940AZ has two external digital interface output headers, J23 and J24, with connections to all eight SDATA_OUT data lines, and two pairs of output LRCLK/BCLK lines. These output headers are hardwired to the AD1940’s serial output ports and are always active.

The I²S/TDM outputs 0-15 correspond to outputs 0-15 in SigmaStudio.

S/PDIF TRANSMITTER

The EVAL-AD1940AZ has an S/PDIF transmitter with both optical and coaxial electrical outputs. These outputs are hardwired to the AD1940 and are always active.

The S/PDIF outputs 0-1 correspond to outputs 8-9 in SigmaStudio.

EXAMPLE CONFIGURATIONS

ANALOG IN/OUT MODE

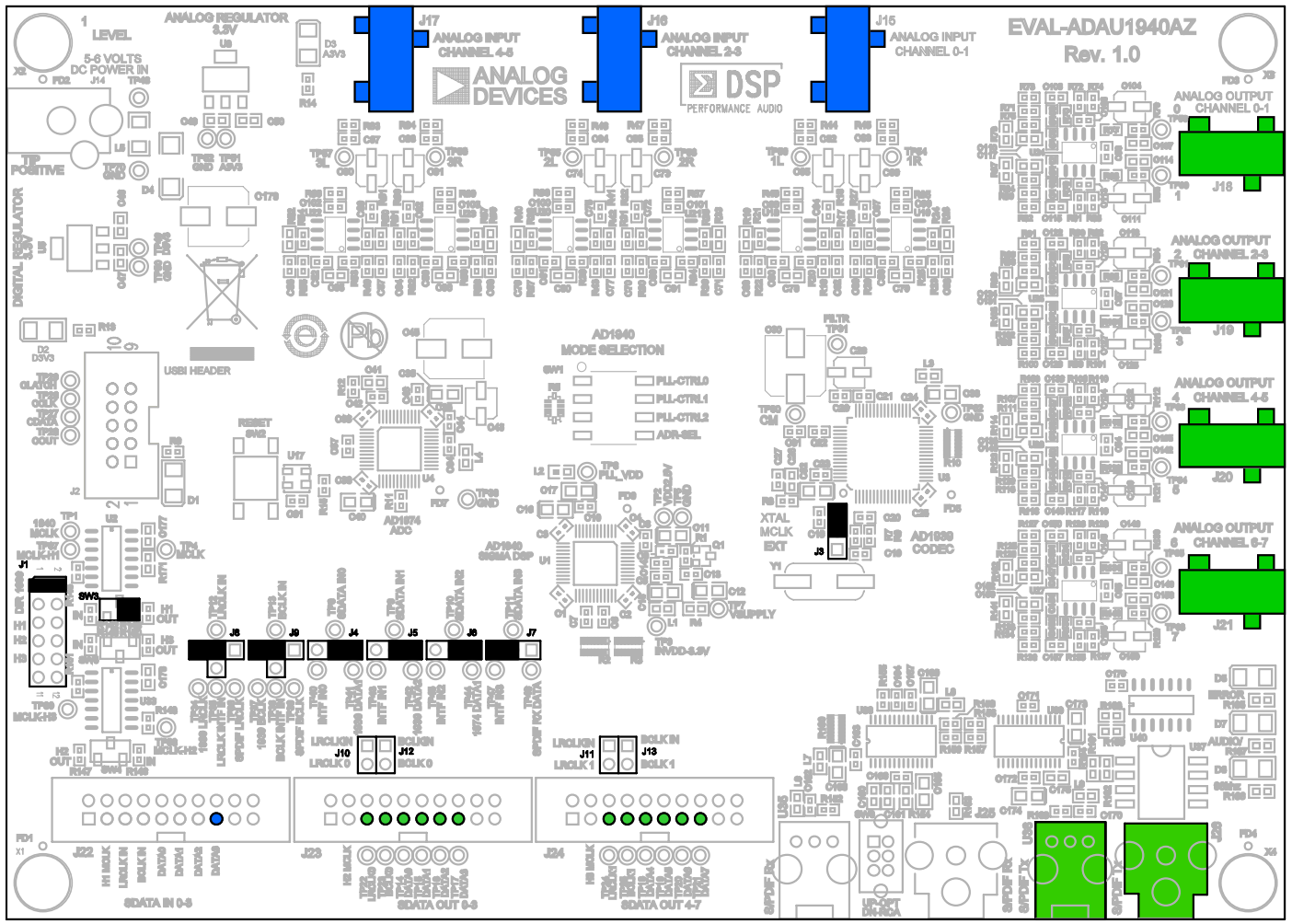
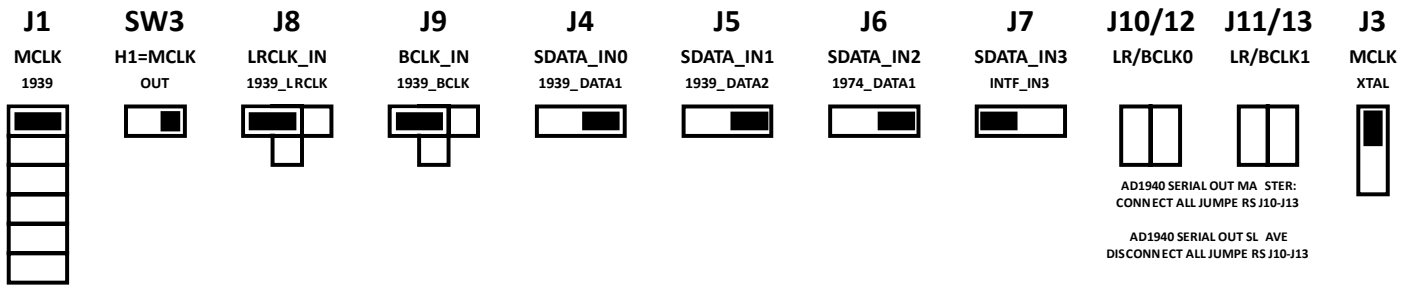
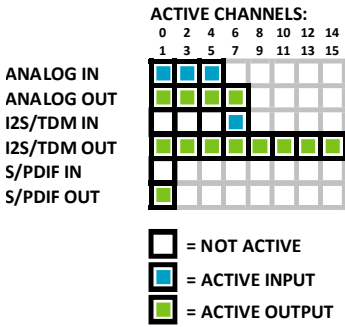

S/PDIF IN/OUT MODE

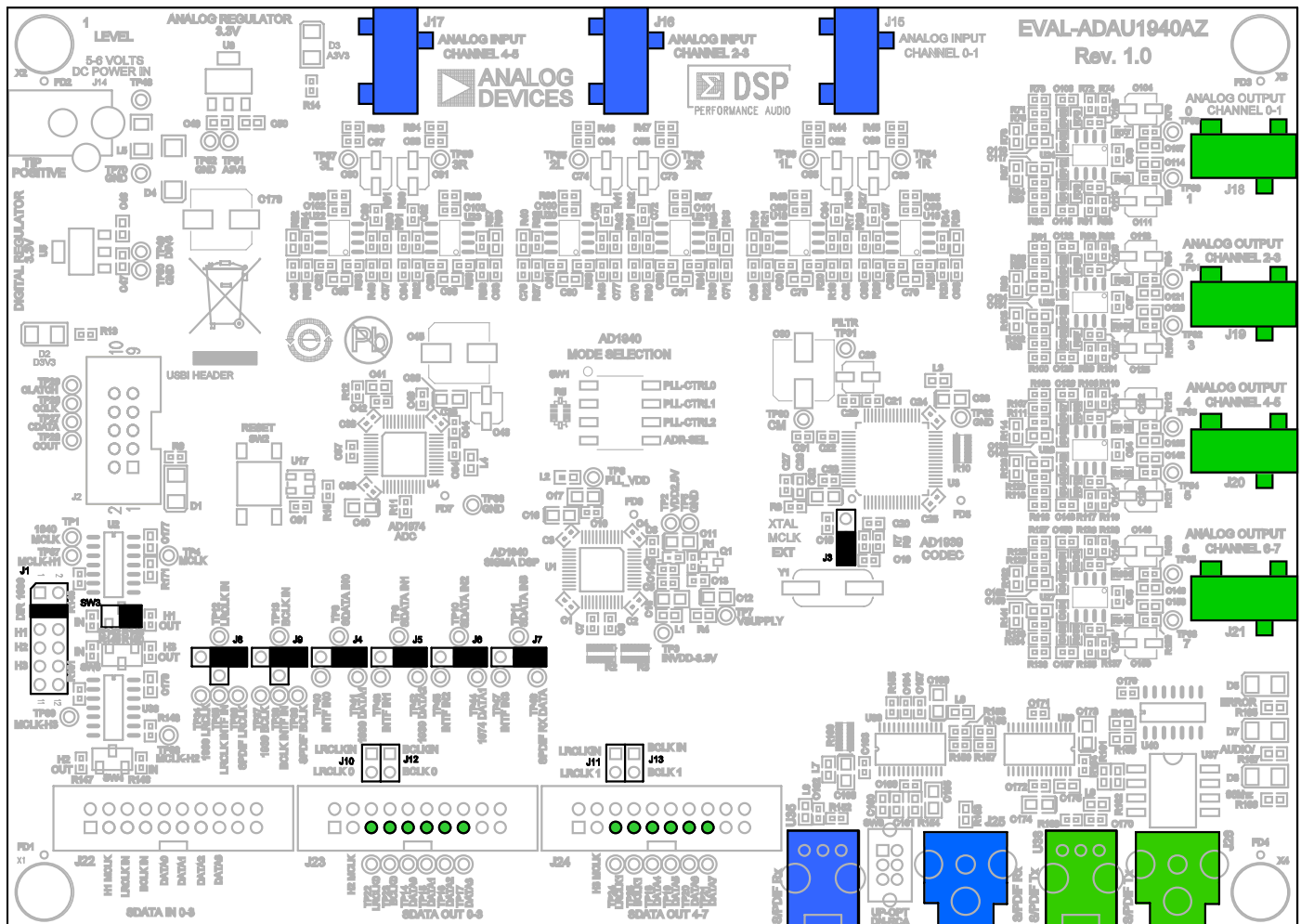
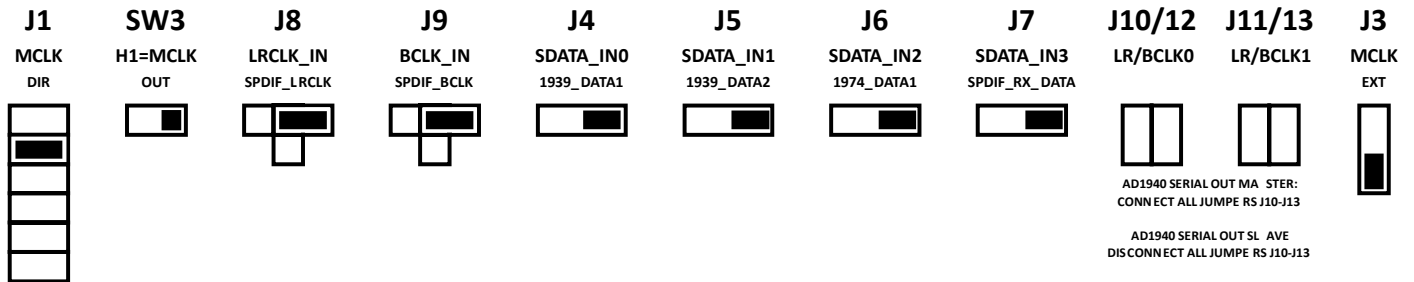
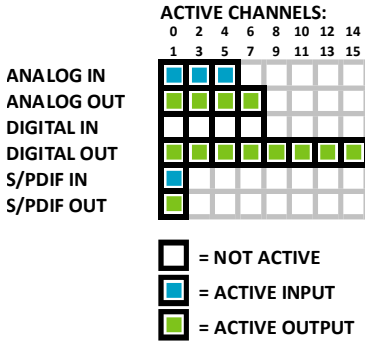

I2S/TDM IN/OUT MODE
(AD1939 XTAL GENERATES MCLK)

ACTIVE CHANNELS:
0 2 4 6 8 10 12 14
1 3 5 7 9 11 13 15

ANALOG IN
ANALOG OUT
DIGITAL IN
DIGITAL OUT
S/PDIF IN
S/PDIF OUT

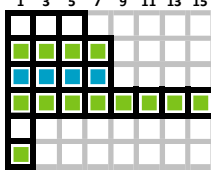

□ = NOT ACTIVE
■ = ACTIVE INPUT
■ = ACTIVE OUTPUT

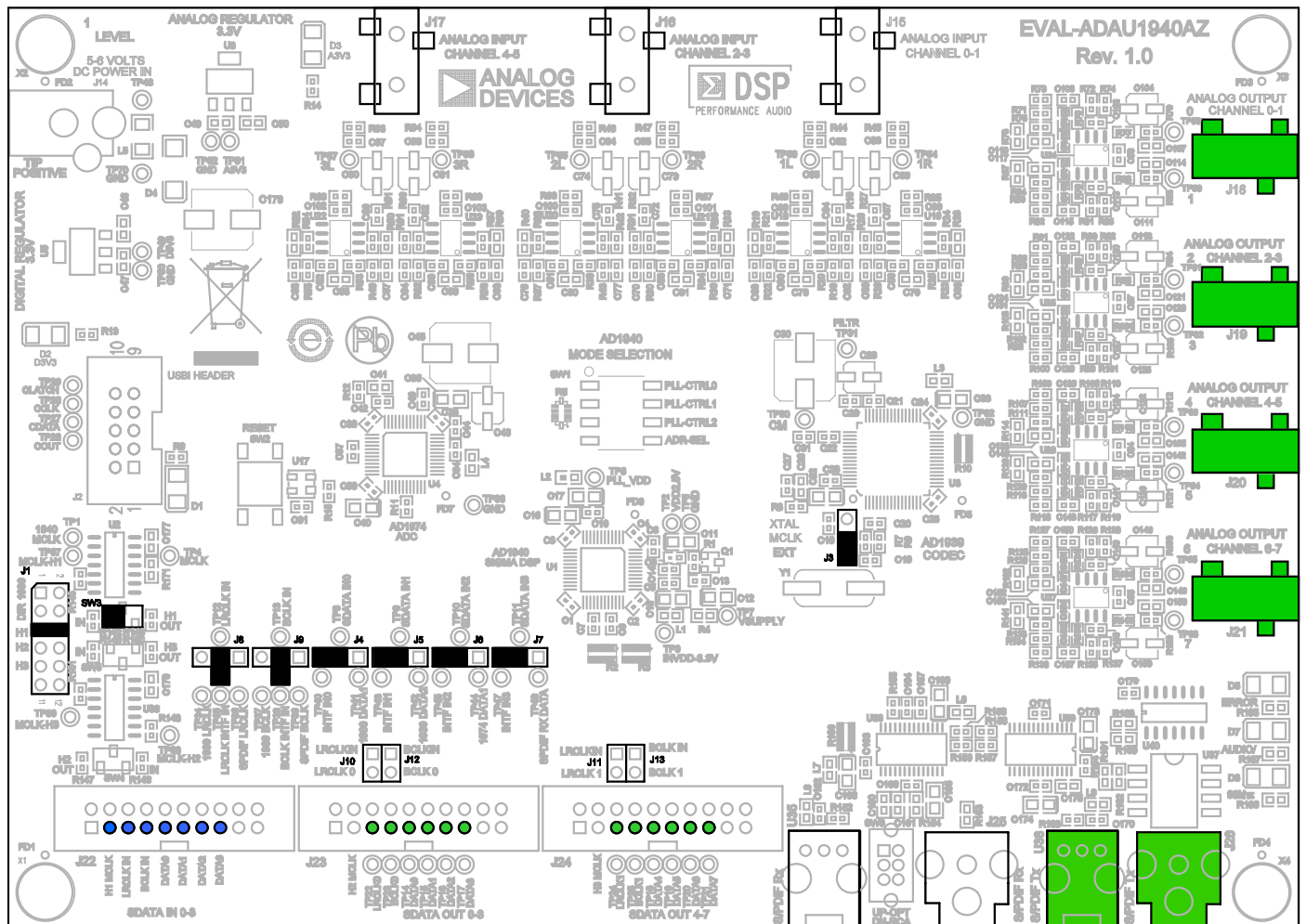
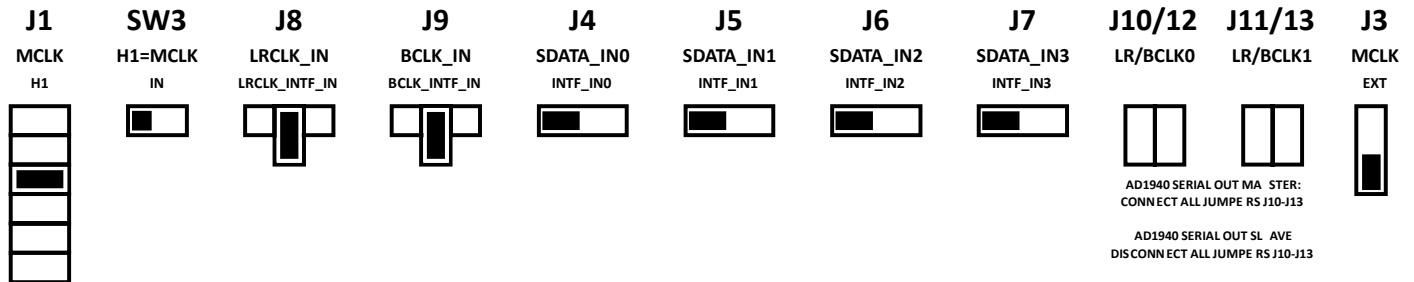

I2S/TDM IN/OUT MODE (EXTERNAL MCLK INPUT ON H1)

ACTIVE CHANNELS:
0 2 4 6 8 10 12 14
1 3 5 7 9 11 13 15

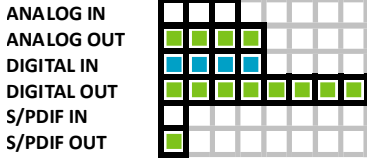

- = NOT ACTIVE
- = ACTIVE INPUT
- = ACTIVE OUTPUT

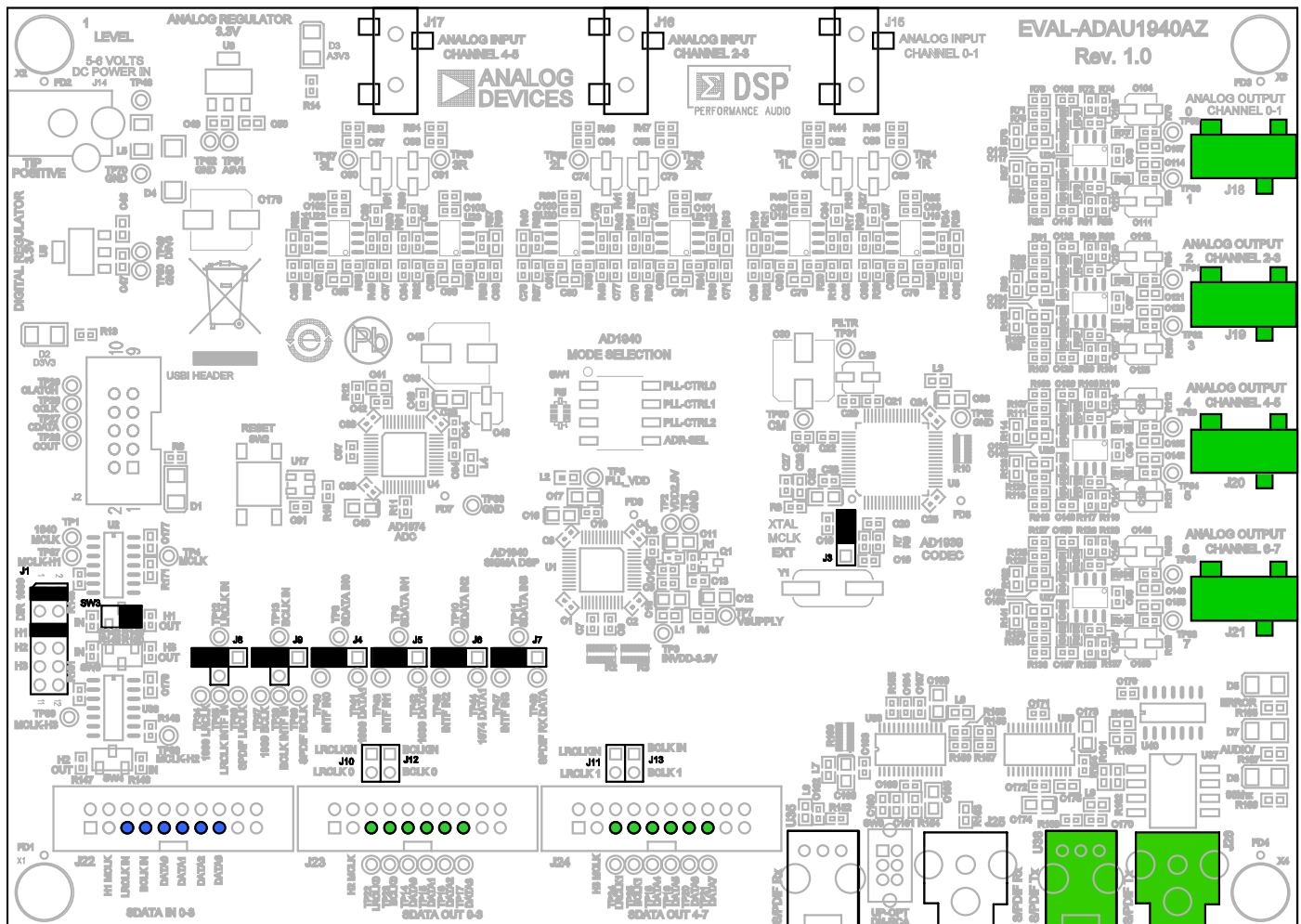
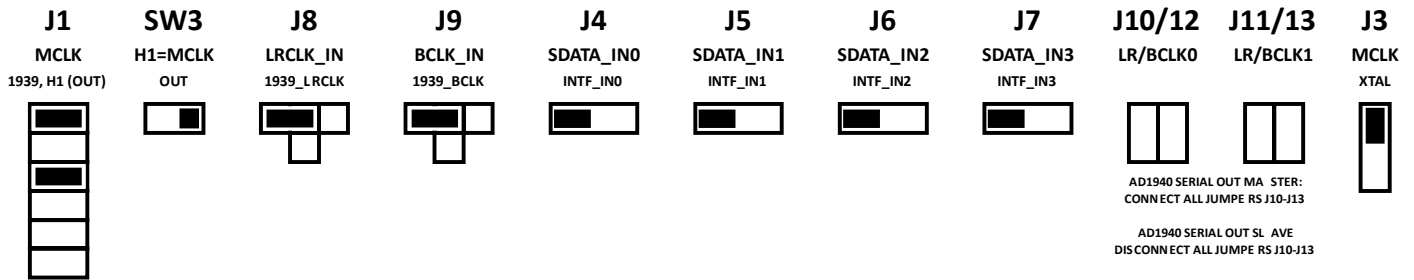

POWER SUPPLIES AND RESET

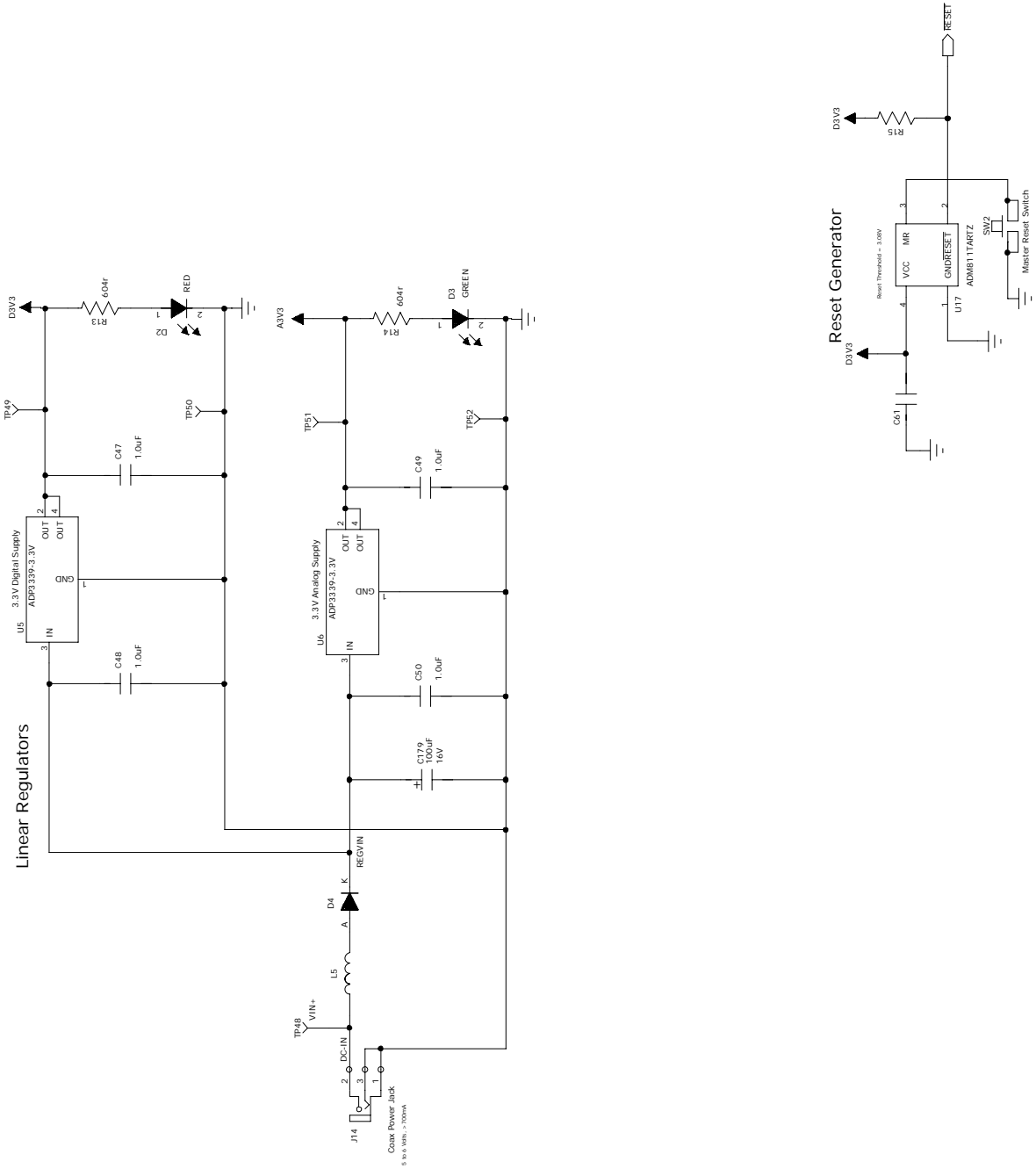

Figure 20. Power Supplies and Reset Schematics

AD1974 ADC

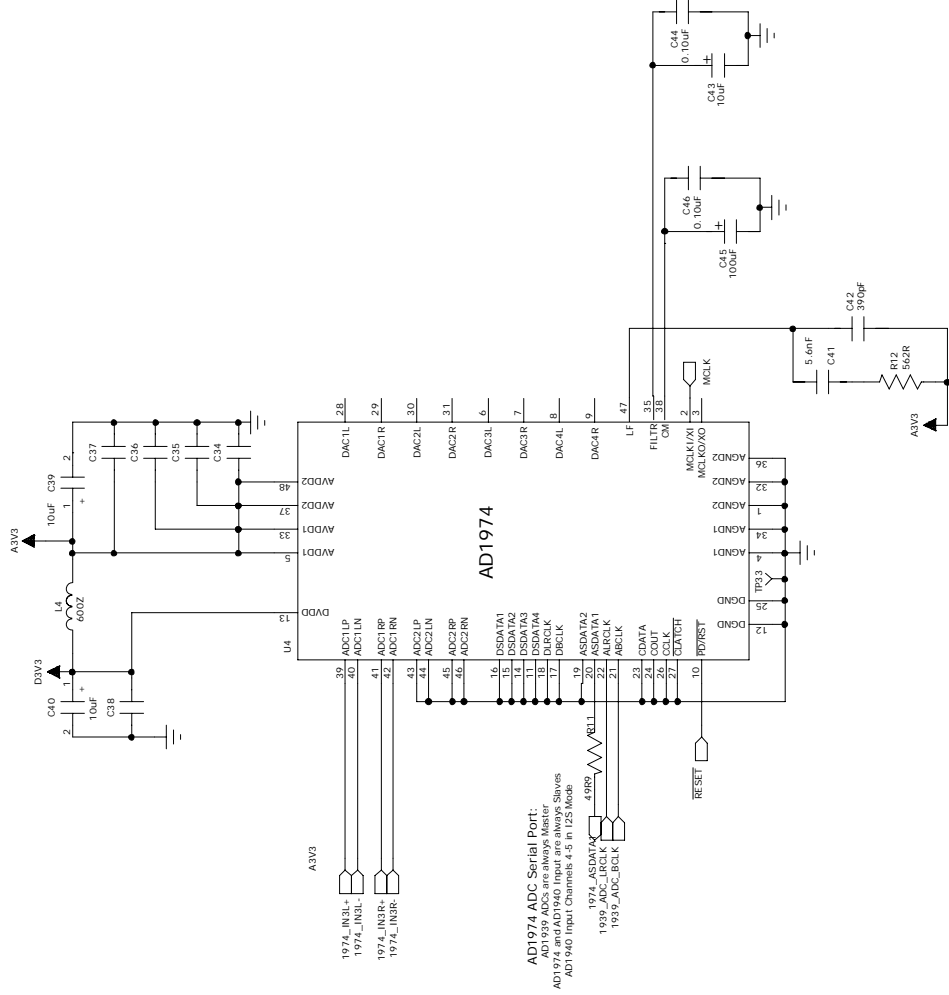

Figure 22. AD1974 ADC Schematics

ANALOG AUDIO INPUT FILTERS

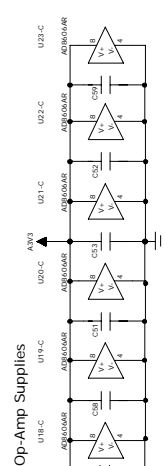
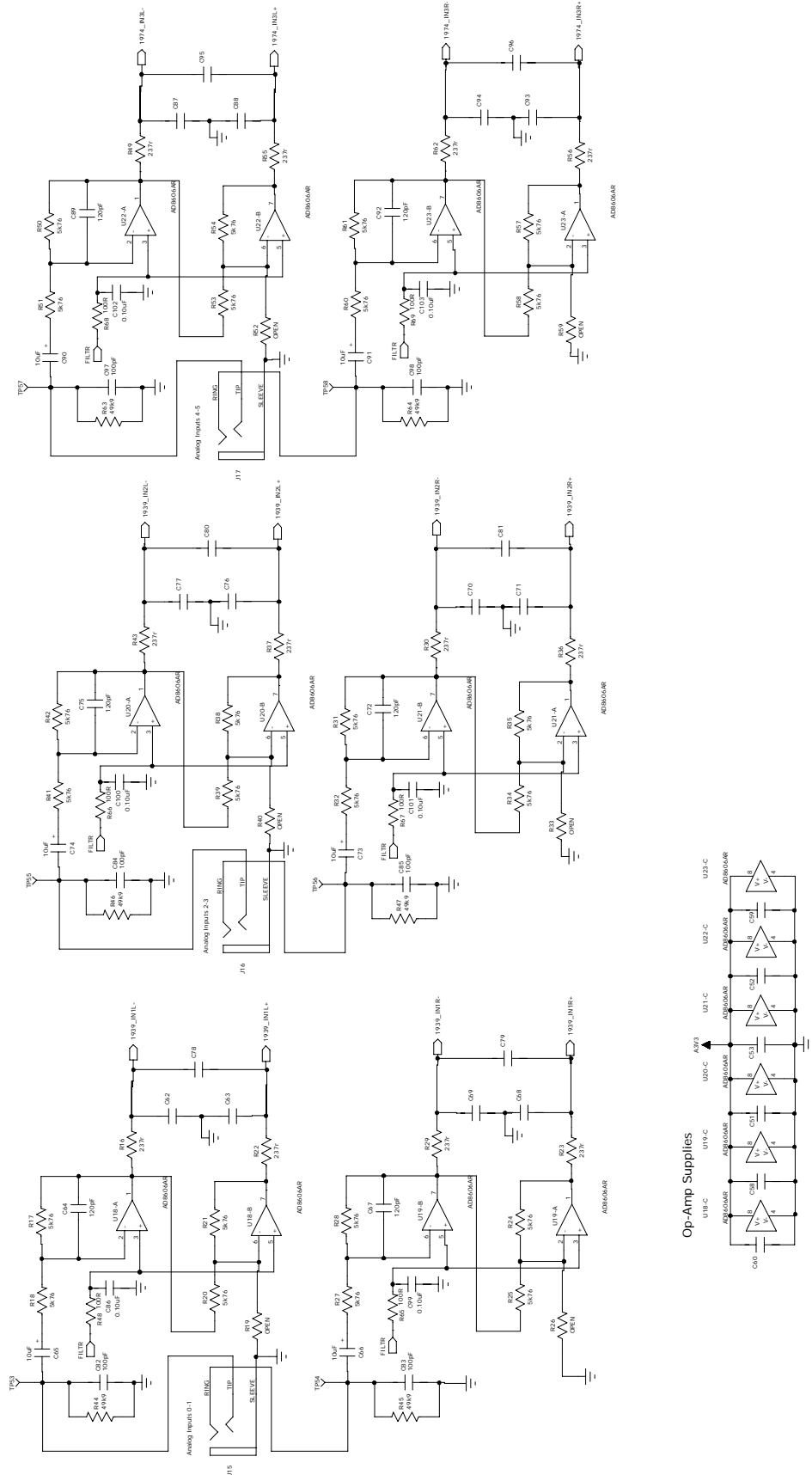

Figure 23. Analog Audio Input Filters Schematics

ANALOG AUDIO OUTPUT FILTERS (1)

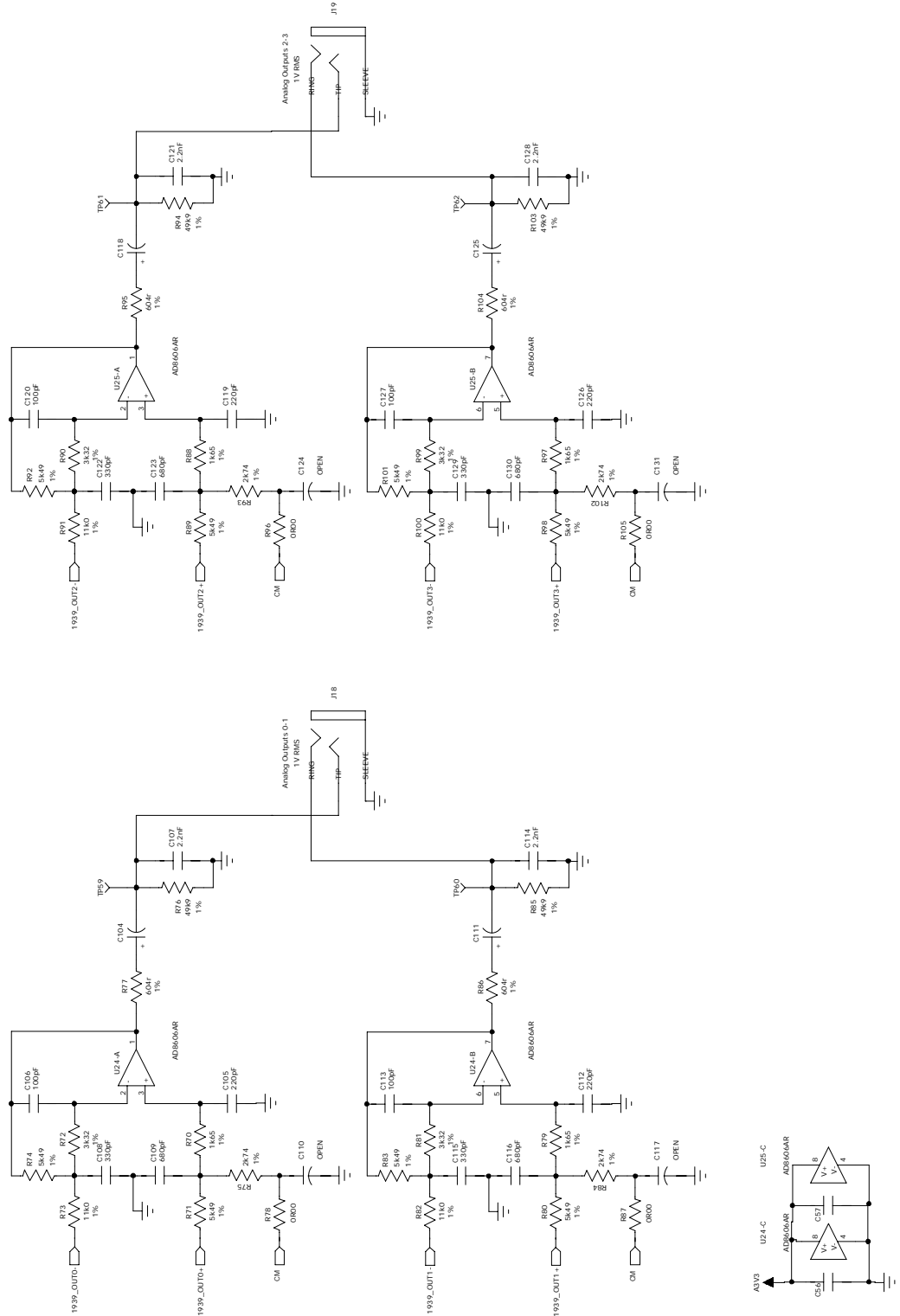

Figure 24. Analog Audio Output Filters (1) Schematics

DIGITAL AUDIO I/O

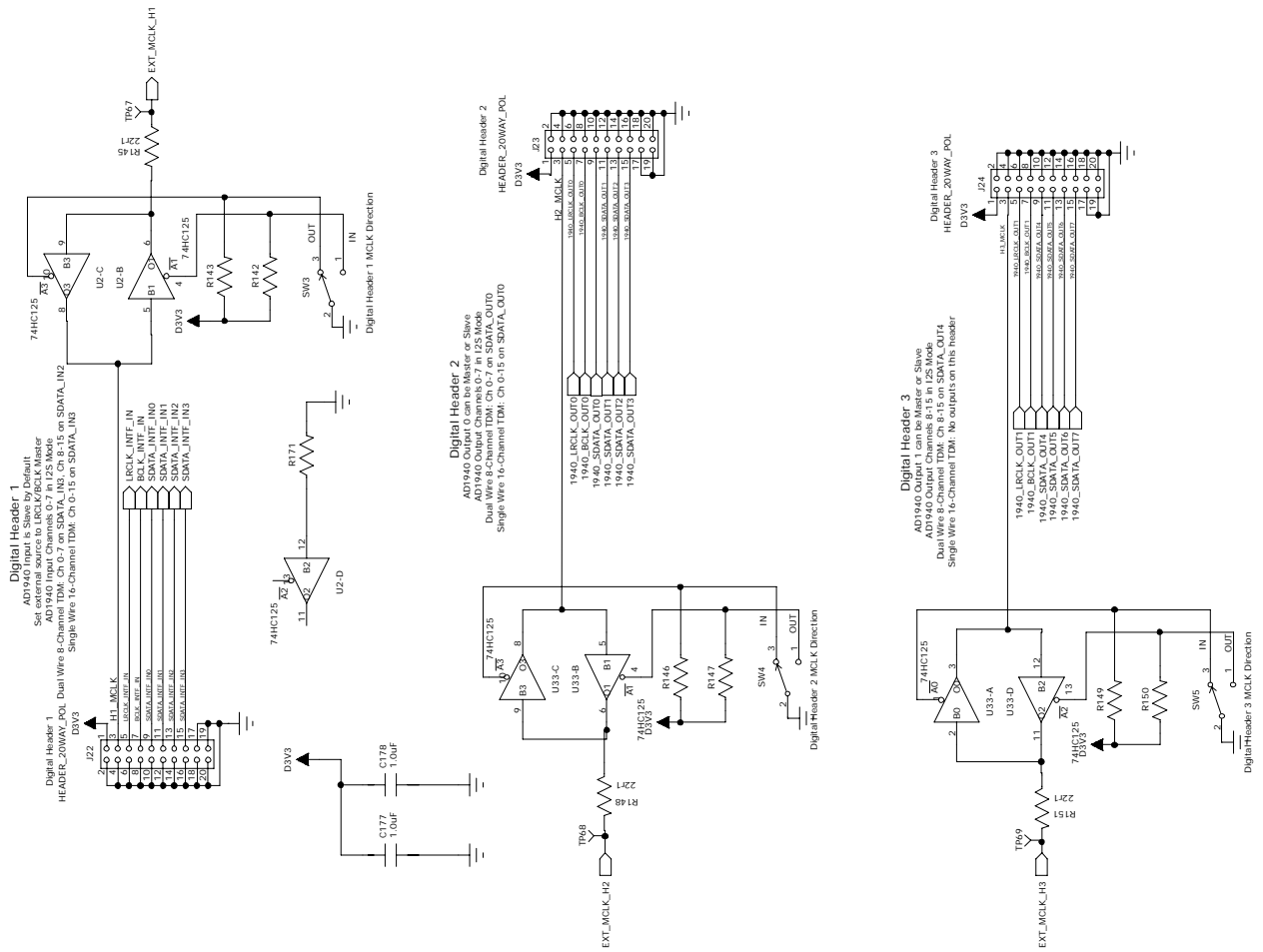

Figure 26. Digital Audio I/O Schematics

AUDIO DATA AND CLOCK ROUTING

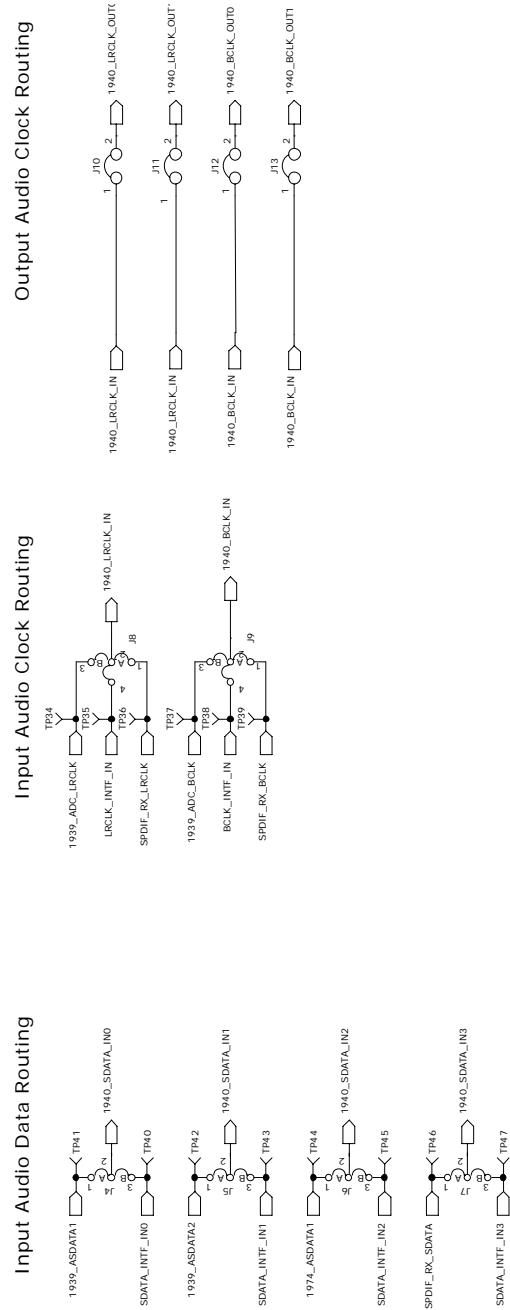

Figure 28. Audio Data and Clock Routing Schematics

BILL OF MATERIALS

Reference	Qty	Value	Manufacturer	Part Number	Description	Vendor	Vendor Order #
C105 C112 C119 C126 C133 C140 C147 C154	8	220pF	Murata ENA	GRM1555C1H221J A01D	Multilayer Ceramic 50V NPO (0402)	Digi-Key	490-1293-1-ND
C107 C114 C121 C128 C135 C142 C149 C156	8	2.2nF NPO	Murata Electronics	GRM1885C1H222J A01D	Multilayer Ceramic 50V NPO (0603)	Digi-Key	490-1459-1-ND
C108 C115 C122 C129 C136 C143 C150 C157	8	330pF	Murata ENA	GRM1555C1H331J A01D	Multilayer Ceramic 50V NPO (0402)	Digi-Key	490-1295-1-ND
C109 C116 C123 C130 C137 C144 C151 C158	8	680pF	Panasonic EC	GRM1555C1H681J A01D	Multilayer Ceramic 50V NPO (0402)	Digi-Key	490-3240-1-ND
C11-12 C15-17 C32-33 C39-40 C168-169 C173- 174	13	10uF	Rohm	TCPOJ106M8R	SMD Tantalum Capacitor 0805 6.3V	Digi-Key	511-1447-1-ND
C160-161	2	10nF	TDK Corp	C1608C0G1E103J	Multilayer Ceramic 25V NPO (0603)	Digi-Key	445-2664-1-ND
C165	1	22nF	Murata ENA	GRM21B5C1H223J A01L	Multilayer Ceramic 25V NPO (0805)	Digi-Key	490-1644-1-ND
C1-7 C9-10 C13-14 C20- 25 C29 C31 C34-38 C44 C46 C51-61 C86 C99-103 C162-164 C167 C170-172 C176	51	0.10uF	Panasonic EC	ECJ-0EX1C104K	Multilayer Ceramic 16V X7R (0402)	Digi-Key	PCC13490CT- ND
C175	1	10nF	Panasonic EC	ECJ-1VB1H103K	Multilayer Ceramic 50V X7R (0603)	Digi-Key	PCC1784CT-ND
C18	1	22pF	Murata ENC	GRM1555C1H220J Z01D	Multilayer Ceramic 50V NPO (0402)	Digi-Key	490-1283-1-ND
C19	1	27pF	Murata ENA	GRM1555C1H270J Z01D	Multilayer Ceramic 50V NPO (0402)	Digi-Key	490-1284-1-ND
C26 C41	2	5.6nF	TDK Corp	C1608C0G1E562J	Multilayer Ceramic 25V NPO (0603)	Digi-Key	445-2666-1-ND
C27 C42	2	390pF	Murata ENA	GRM1555C1H391J A01D	Multilayer Ceramic 50V NPO (0402)	Digi-Key	490-1296-1-ND
C28 C43 C65-66 C73-74 C90-91 C104 C111 C118 C125 C132 C139 C146 C153	16	10uF	Panasonic EC	EEE-FC1C100R	Alum Electrolytic Capacitor FC 105deg SMD_B	Digi-Key	PCE3995CT-ND
C30 C45 C179	3	100uF	Panasonic EC	EEE-FC1C101P	Alum Electrolytic Capacitor FC 105deg SMD_E	Digi-Key	PCE3996CT-ND
C47-50 C177-178	6	1.0uF	Taiyo Yuden	EMK107BJ105KA- TR	Multilayer Ceramic 16V X7R (0603)	Digi-Key	587-1241-1-ND
C64 C67 C72 C75 C89 C92 C78-81 C95-96 C110 C117 C124 C131 C138 C145 C152 C159	14	OPEN	n/a	n/a	Do not stuff anything here	n/a	n/a
C8 C62-63 C68-71 C76-77 C87-88 C93-94 C166	14	1.0nF	Murata ENA	GRM1555C1H102J A01D	Multilayer Ceramic 50V NPO (0402)	Digi-Key	490-3244-1-ND
C82-85 C97-98 C106 C113 C120 C127 C134 C141 C148 C155	14	100pF	Murata ENA	GCM1555C1H101J Z13D	Multilayer Ceramic 50V NPO (0402)	Digi-Key	490-4756-1-ND
D1	1	Yellow Diffused	CML Innovative Tech	CMD15- 21VYD/TR8	Yellow Diffused 4.0millicandela 585nm 1206	Digi-Key	L62307CT-ND
D2 D5	2	Red Diffused	Lumex Opto	SML-LX1206IW-TR	Red Diffused 6.0millicandela 635nm 1206	Digi-Key	67-1003-1-ND
D3 D6	2	Green Diffused	Lumex Opto	SML-LX1206GW- TR	Green Diffused 10millicandela 565nm 1206	Digi-Key	67-1002-1-ND
D4	1		Micro Commercial Co.	DL4001-TP	Passivated Rectifier 1A 50V MELF	Digi-Key	DL4001- TPMSCT-ND
D7	1	Yellow Diffused	CML Innovative Tech	CMD15- 21VYD/TR8	Yellow Diffused 4.0millicandela 585nm 1206	Digi-Key	L62307CT-ND
J1	1	2x6	3M	PBC06DAAN	or cut PBC36DAAN	Digi-Key	S2011E-06-ND

J10-13	4	2-Jumper	Sullins Electronics Corp	PBC02SAAN; or cut PBC36SAAN	2-pin Header Unshrouded Jumper 0.10"; use Shunt Tyco 881545-2	Digi-Key	S1011E-02-ND
J14	1	RAPC722X	Switchcraft Inc.	RAPC722X	Mini Power Jack 0.08" R/A TH	Digi-Key	SC1313-ND
J15-21	7	SJ-3523-SMT	CUI Inc.	SJ-3523-SMT	Sterero Mini Jack SMT	Digi-Key	CP-3523SJCT-ND
J2	1	2x5	3M	N2510-6002RB	10-way Shroud Polarized Header	Digi-Key	MHC10K-ND
J22-24	3	2x10	3M	N2520-6002RB	20-way Shroud Polarized Header	Digi-Key	MHC20K-ND
J25-26	2	CTP-021A-S-YEL	Connect-Tech Products Corp.	CTP-021A-S-YEL	RCA Jack PCB TH Mount R/A Yellow	connect-tech-products.com	CTP-021A-S-YEL
J3-7	5	3-Jumper	Sullins	PBC03SAAN; or cut PBC36SAAN	3-pos SIP Header	Digi-Key	S1011E-03-ND
J8-9	2	3jumper + 1jumper	Sullins	PBC03SAAN; or cut PBC36SAAN	3-pos SIP Header + 1 extra pin	Digi-Key	S1011E-03-ND +S1011E-01-ND
L1-4 L6-9	8	600 Ohm @ 100 MHz	TDK Corp	MPZ1608S601A	Chip Ferrite Bead 600 Ohm @ 100 MHz	Digi-Key	445-2205-1-ND
L5	1	600 Ohm @ 100 MHz	Steward	HZ1206E601R-10	Chip Ferrite Bead 600 Ohm @ 100 MHz	Digi-Key	240-2415-1-ND
Q1	1	ZXTP25040D FHTA	Zetex Inc.	ZXTP25040DFHTA	PNP Transistor 40V 3A SOT-23	Digi-Key	ZXTP25040DFHCT-ND
R1	1	1k00	Panasonic EC	ERJ-2RKF1001X	Chip Resistor 1% 63mW Thick Film 0402	Digi-Key	P1.00KLCT-ND
R145 R148 R151	3	22R1	Vishay/Dale	CRCW040222R1FK ED	Chip Resistor 1% 63mW Thick Film 0402	Digi-Key	541-22.1LCT-ND
R15 R142-143 R146-147 R149-150 R152 R163	9	10k0	Rohm	MCR01MZPF1002	Chip Resistor 1% 63mW Thick Film 0402	Digi-Key	RHM10.0KLCT-ND
R153	1	75R0	Panasonic EC	ERJ-3EKF75R0V	Chip Resistor 1% 100mW Thick Film 0603	Digi-Key	P75.0HCT-ND
R154	1	3k01	Rohm	MCR03EZPFX3011	Chip Resistor 1% 100mW Thick Film 0603	Digi-Key	RHM3.01KHCT-ND
R155-159 R164	6	47k5	Rohm	MCR01MZPF4752	Chip Resistor 1% 63mW Thick Film 0402	Digi-Key	RHM47.5KLCT-ND
R16 R22-23 R29-30 R36-37 R43 R49 R55-56 R62	12	237R	Vishay/Dale	CRCW0402237RFK ED	Chip Resistor 1% 63mW Thick Film 0402	Digi-Key	541-237LCT-ND
R161	1	374R	Rohm	MCR03EZPFX3740	Chip Resistor 1% 100mW Thick Film 0603	Digi-Key	RHM374HCT-ND
R162	1	90R9	Rohm	MCR03EZPFX90R9	Chip Resistor 1% 100mW Thick Film 0603	Digi-Key	RHM90.9HCT-ND
R165-167	3	392R	Rohm	MCR03EZPFX3920	Chip Resistor 1% 100mW Thick Film 0603	Digi-Key	RHM392HCT-ND
R17-18 R20-21 R24-25 R27-28 R31-32 R34-35 R38-39 R41-42 R50-51 R53-54 R57-58 R60-61	24	5k76	Panasonic EC	ERJ-2RKF5761X	Chip Resistor 1% 63mW Thick Film 0402	Digi-Key	P5.76KLCT-ND
R19 R26 R33 R40 R52 R59	6	OPEN	Do Not Stuff	OPEN	Do Not Stuff	OPEN	OPEN
R2-3 R10 R160	4	56R0	CTS Corp.	741X163560JP	Resistor Network Isolated 8Res	Digi-Key	741X163560JPC T-ND
R4 R78 R87 R96 R105 R114 R123 R132 R141 R168-169 R171	12	0R00	Panasonic EC	ERJ-3GEY0R00V	Chip Resistor 5% 125mW Thick Film 0603	Digi-Key	P0.0GCT-ND
R44-47 R63-64 R76 R85 R94 R103 R112 R121 R130 R139	14	49k9	Vishay/Dale	CRCW040249K9FK ED	Chip Resistor 1% 63mW Thick Film 0402	Digi-Key	541-49.9KLCT-ND
R5	1	10k0	Panasonic EC	EXB-D10C103J	Resistor Network Bussed 8Res	Digi-Key	U9103CT-ND
R6 R13-14 R77 R86 R95 R104 R113 R122 R131 R140	11	604R	Vishay/Dale	CRCW0402604RFK ED	Chip Resistor 1% 63mW Thick Film 0402	Digi-Key	541-604LCT-ND
R7 R48 R65-69	7	100R	Rohm	MCR01MZPF1000	Chip Resistor 1% 63mW Thick Film 0402	Digi-Key	RHM100LCT-ND

R70 R79 R88 R97 R106 R115 R124 R133	8	1k65	Vishay/Dale	CRCW04021K65FK ED	Chip Resistor 1% 63mW Thick Film 0402	Digi-Key	541-1.65KLTR- ND
R71 R74 R80 R83 R89 R92 R98 R101 R107 R110 R116 R119 R125 R128 R134 R137	16	5k49	Rohm	MCR01MZPF5491	Chip Resistor 1% 63mW Thick Film 0402	Digi-Key	RHM5.49KLCT- ND
R72 R81 R90 R99 R108 R117 R126 R135	8	3k32	Vishay/Dale	CRCW04023K32FK ED	Chip Resistor 1% 63mW Thick Film 0402	Digi-Key	541-3.32KLCT- ND
R73 R82 R91 R100 R109 R118 R127 R136	8	11k0	Yageo	RC0402FR-0711KL	Chip Resistor 1% 63mW Thick Film 0402	Digi-Key	311-11.0KLRCT- ND
R75 R84 R93 R102 R111 R120 R129 R138	8	2k74	Vishay/Dale	CRCW04022K74FK ED	Chip Resistor 1% 63mW Thick Film 0402	Digi-Key	541-2.74KLCT- ND
R8 R12	2	562R	Vishay/Dale	CRCW0402562RFK ED	Chip Resistor 1% 63mW Thick Film 0402	Digi-Key	541-562LCT-ND
R9 R11	2	49R9	Rohm	MCR01MZPF49R9	Chip Resistor 1% 63mW Thick Film 0402	Digi-Key	RHM49.9LCT- ND
SW1	1	8x SPST	CTS Corp	219-4LPST	4 Section SPST SMD Switch Raised Act	Digi-Key	CT2194LPST- ND
SW2	1	SPST-NO	Tyco/Alcoswitch	FSM6JSMA	Tact Switch 6mm Gull Wing	Digi-Key	450-1133-ND
SW3-5	3	SPDT	Copal Electronics	CAS-120TA	SPDT Slide Switch SMD J Hook	Digi-Key	CAS120JCT-ND
SW6	1	DPDT Slide	E-Switch	EG2207	DPDT Slide Switch Vertical	Digi-Key	EG1940-ND
TP1-70	70	5002	Keystone Electronics	5002	Mini Test Point White .1" OD	Digi-Key	5002K-ND
U1	1	AD1940YSTZ	Analog Devices Inc.	AD1940YSTZ	SigmaDSP Multi-Channel 28-bit Audio Processor	Analog Devices Inc.	AD1940YSTZ
U17	1	ADM811TAR TZ-REEL7	Analog Devices Inc.	ADM811TARTZ- REEL7	µP Voltage Supervisor Logic Low RESET Output	Analog Devices Inc.	ADM811TARTZ- REEL7
U18-27	10	AD8606ARZ	Analog Devices Texas Instruments	AD8606ARZ	Low-Noise Rail-to-Rail CMOS Op Amp	Analog Devices	AD8606ARZ
U2 U33	2	74AC125SC	Texas Instruments	74AC125SC	IC BUFFER QUAD 3 STATE 14- SOIC	DigiKey	74AC125SC-ND
U3	1	AD1939YSTZ	Analog Devices	AD1939YSTZ	4 ADC/8 DAC with PLL	Analog Devices	AD1939YSTZ
U35	1	TORX147L(F T)	Toshiba	TORX147L(FT)	15Mb/s Fiber Optic Receiving Module w/ Shutter	Digi-Key	TORX147LFT- ND
U36	1	CS8416-CZZ	Cirrus Logic	CS8416-CZZ	192KHZ DGTL RCVR 28-TSSOP	Digi-Key	598-1124-5-ND
U37	1	SC937-02	Scientific Conversion	SC937-02	110 Ohm AES/EBU Transformer	www.sci entificon version.c om	SC937-02
U38	1	TOTX147L(FT)	Toshiba	TOTX147L(FT)	Fiber Optic Transmit Module 15Mb/s w/ Shutter	Digi-Key	TOTX147L-ND
U39	1	CS8406-CZZ	Cirrus Logic	CS8406-CZZ	192kHz SPDIF Transmitter	Newark In One	88H6508
U4	1	AD1974YSTZ	Analog Devices	AD1974YSTZ	4 ADC 8DAC with PLL 192kHz 24-bit CODEC	Analog Devices	AD1974YSTZ
U40	1	74HC04D-T	NXP Semi	74HC04D-T	IC INVERTER HEX TTL/LSTTL 14SOIC	DigiKey	568-1384-1-ND
U5-6	2	ADP3339AK CZ-3.3-R7	Analog Devices Inc.	ADP3339AKCZ- 3.3-R7	High-Accuracy low-Dropout 3.3VDC Voltage Regulator	Analog Devices Inc.	ADP3339AKCZ- 3.3-R7
Y1	1	12.288MHz	Citizen America Corp	HCM49- 12.288MABJ-UT	CRYSTAL 12.288 MHZ SMT 18PF	Digi-Key	300-8550-1-ND

ORDERING GUIDE

ORDERING GUIDE

Model	Description
EVAL-AD1940AZ	Evaluation Board

ESD CAUTION

ESD (electrostatic discharge) sensitive device. Electrostatic charges as high as 4000V readily accumulate on the human body and test equipment and can discharge without detection. Although this product features proprietary ESD protection circuitry, permanent damage may occur on devices subjected to high energy electrostatic discharges. Therefore, proper ESD precautions are recommended to avoid performance degradation or loss of functionality.



NOTES