

**Instrumentation Amplifiers  
Solve Unusual Design Problems**

by Scott Wurcer and Walt Jung

*Traditionally considered only for transducer-conditioning applications, instrumentation amplifiers bring unique performance benefits to a range of other applications as well.*

Instrumentation amplifiers traditionally find use in transducer-signal-conditioning applications that require gain blocks with true differential inputs and single-ended outputs. But the same instrumentation-

amp performance characteristics that suit sensor-based circuits—such as strain-gauge and thermocouple amplifiers—also benefit many less traditional analog-signal-

10

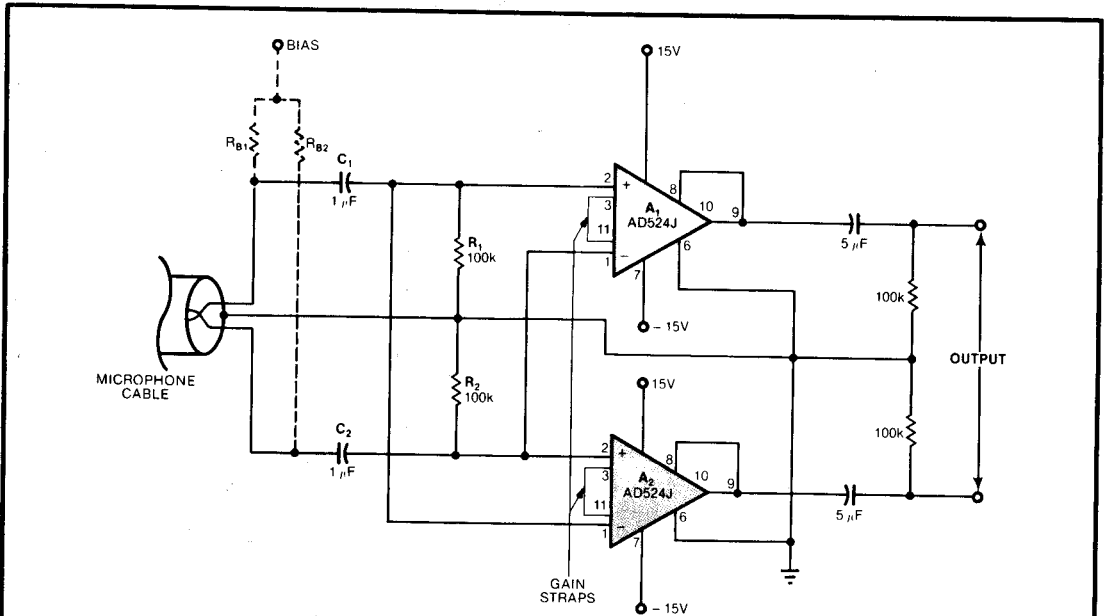

**Fig 1—An active-transformer microphone preamp uses two instrumentation amps for reduced noise. In this circuit, the instrumentation amps' output signals add linearly, while noise adds according to the square root of two. Thus, the circuit provides 3-dB better noise performance than do single-ended designs.**

# Instrumentation amplifiers find diverse uses

processing applications. Indeed, as the circuits presented here illustrate, emerging low-cost monolithic instrumentation amplifiers often prove preferable to op amps as basic analog-circuit building blocks.

IC instrumentation amps' advantages stem from their use of multiple op amps to provide balanced inverting and noninverting inputs, high common-mode-rejection ratios (CMRRs) and programmable front-end gains (see box, "Three op amps are better than one"). High-performance devices combine low input noise voltages with wide bandwidths and stable dc character-

istics—attributes that don't coexist in most monolithic op amps. Thus, instrumentation amps frequently outperform op amps in applications as simple as noninverting gain stages (see box, "The instrumentation amp as op amp").

## Simplifying mike preamps

But instrumentation amps' most interesting applications involve circuits entailing performance problems that op amps typically can't solve. Microphone preamplifiers, for example, require active stages exhibiting

### Three op amps are better than one

Instrumentation amplifiers typically consist of three op amps configured as a dual differential input stage and an output buffer (figure, part (a)). Internal feedback resistors connected to the input amplifiers allow one resistor ( $R_G$ ) to set overall gain. Assuming a unity-gain output configuration, overall gain equals  $((R_1 + R_2)/R_G) + 1$ . Sense and reference inputs allow output gain scaling and offsetting.

The monolithic instrumentation amps used in this article's circuits, Analog Devices's AD524 and AD624 (figure, part (b)), possess

the same gain characteristics as the classic 3-op-amp circuit but provide a few added features. They include transistor preamps ( $Q_1$  and  $Q_2$ ) that precede input amplifiers  $A_1$  and  $A_2$ . As a result, input gain-bandwidth product depends on transistor transconduc-

tance, so the circuits provide greater high-gain bandwidth than do conventional instrumentation amps. The transistor preamps also increase overall instrumentation-amp gain and thus reduce closed-loop errors.

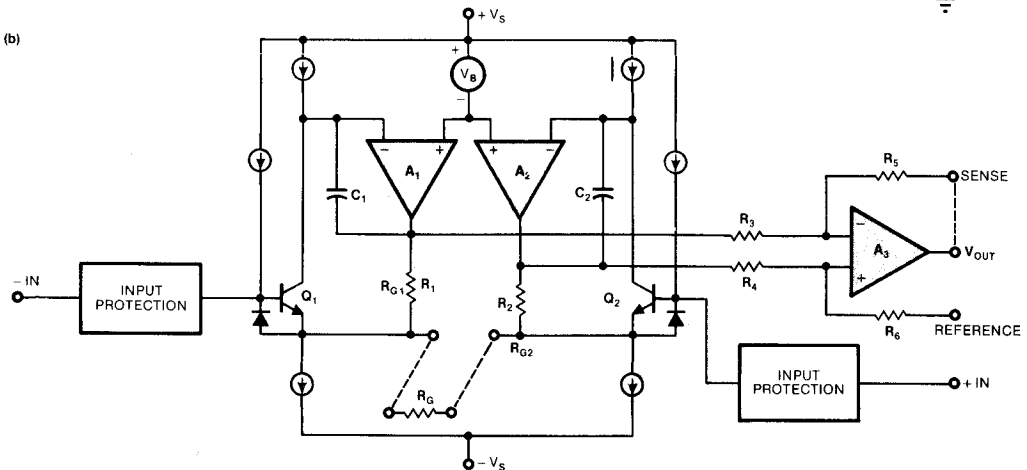
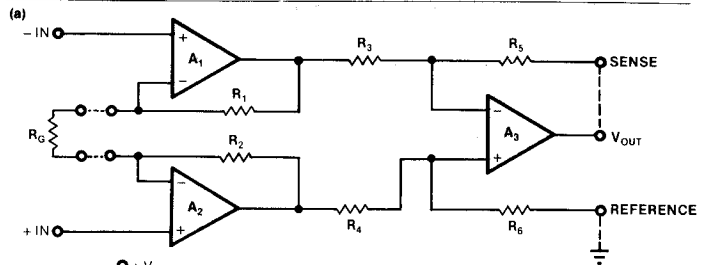

Three op amps compose a typical instrumentation amp (a). Internal feedback resistors around the input amplifiers let one resistor ( $R_G$ ) set overall circuit gain. The monolithic instrumentation amps used in this article's circuits (b) include transistor preamps that extend circuit bandwidth and reduce closed-loop distortion.

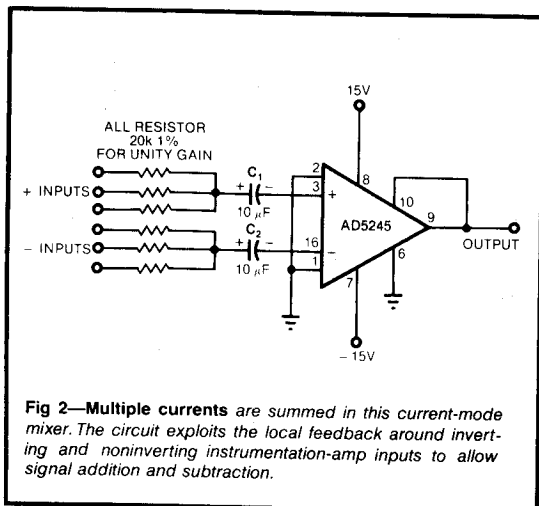

**Fig 2—Multiple currents** are summed in this current-mode mixer. The circuit exploits the local feedback around inverting and noninverting instrumentation-amp inputs to allow signal addition and subtraction.

remain adequately protected. The AD524 includes integral protection to 36V; other instrumentation amps might require 1-kΩ or larger resistors in series with the coupling capacitors. Note, though, that input resistors entail a noise penalty. A 1-kΩ resistor generates 4-nV/√Hz equivalent input noise, which adds in rms fashion to instrumentation-amp input noise (4.7-nV/√Hz for the AD524 in this circuit).

When constructing the mike preamp, be certain to shield the coupling capacitors and their associated input circuitry. In addition, for minimum hum pickup, use balanced, twisted-pair input cables.

### Current summer combines audio signals

Fig 2 illustrates another instrumentation-amp application involving audio-frequency signals. Here, an instrumentation-amp-based current summer linearly combines an arbitrary number of input waveforms, allowing independent sign selection for each signal. The summer accommodates individual gain settings for each discrete input, and gain values can exceed or remain less than unity.

To provide dual-polarity summing, the circuit exploits the local feedback present in each of the instrumentation amp's input stages. Because the amplifier's input transistors incorporate local emitter feedback, when the transistor bases (pins 1 and 2) connect to ground, the total current fed into the emitters (pins 3 and 16) produces linearly dependent output voltages. The AD524 incorporates 20-kΩ feedback resistors, so unity gain results from the use of 20-kΩ input resistors.

In Fig 2's circuit, pin 16 serves as a noninverting input and pin 3 acts as an inverting node. You can use the two inputs separately to sum single-ended currents, or together to algebraically combine differential inputs. Because of internal feedback connections, each input's dynamic impedance remains less than 1Ω at frequencies less than 1 kHz, so crosstalk between individual signal channels remains low. With 20-kΩ input resistors (unity gain), for example, interchannel crosstalk remains 86 dB below input levels.

Because the input transistors' grounded bases force emitter voltages to a level one  $V_{BE}$  drop less than ground, you must use input-coupling capacitors to ensure low offsets. Choose the values of these capacitors so that their reactances at frequencies of interest remain low compared with the input resistors' values; otherwise, gain errors result.

Thanks to the instrumentation amp's low input noise, the summer's signal-to-noise ratio over a 20-kHz bandwidth exceeds 90 dB relative to a 1V input. Moreover, total harmonic distortion remains less than 0.01% over the entire audio range. Gain accuracy, however, depends on matching between input resistors

both low noise and high CMRR and thus place excessive demands on conventional op amps. By providing dual differential inputs, low-noise input stages and easily settable gain, instrumentation amps greatly simplify mike-preamp design.

Fig 1 illustrates a preamplifier built from two Analog Devices AD524J monolithic instrumentation amps. Similar to the crossed-input stacked amplifier described in Ref 1, the circuit functions as a balanced-input/balanced-output active transformer. Its differential output configuration provides a 3-dB signal-to-noise-ratio increase compared with single-ended designs: The 2-amp configuration produces twice the signal voltage of a single-amp circuit while generating only  $\sqrt{2}$  times as much noise. The preamp's differential output arrangement also suits non-audio-related applications. For instance, the circuit can function as a general-purpose active transformer that feeds instrumentation amps further down the signal paths.

For maximum application flexibility, the instrumentation amps' programmable front ends allow overall circuit gains of 20, 200 or 2000. When configured as shown for a gain of 20, the preamp provides 40V p-p output swings, 80-dB CMRR, 0.6-μV-rms noise over a 20-kHz bandwidth, and harmonic distortion less than 0.01%.

The preamp's inputs are ac coupled to a source microphone through capacitors  $C_1$  and  $C_2$ ; resistors  $R_1$  and  $R_2$  serve as return paths for the instrumentation amps' input bias currents. The coupling capacitors furnish ac and dc overload protection for levels to a few volts, but because input transients can become quite large (particularly when mike cables get connected or disconnected), you should ensure that the amplifiers

## High common-mode rejection benefits audio applications

and the instrumentation amp's internal feedback elements. The AD524's 20% feedback-resistor tolerance leads to uncompensated gain errors of  $\pm 1.6$  dB in circuits set for unity gain; you can eliminate such errors by providing input-resistor trimming potentiometers. Note, though, that interchannel gain matching isn't affected by internal tolerances. Because all inputs feed a common node, gain matching depends only on input-resistor tolerances.

Note also that you can use the summer with current-mode analog switches, such as those found in DACs. In such applications, you can preserve dc coupling throughout the circuit by connecting the input transistors' bases to a positive voltage equal to the devices'  $V_{BE}$ . In that case, the emitters rest at ground.

### Buffer a bucket brigade

Instrumentation amplifiers' true differential characteristics also prove beneficial in circuits incorporating

analog delay lines. For minimum clock feedthrough and distortion in such circuits, dual CCD bucket-brigade registers—such as Reticon Corp's SAD-1024—provide two independently addressable delay lines with separate clock inputs. But fully exploiting CCD devices' differential capabilities requires buffer amplifiers with well-balanced inputs.

Fig 3 illustrates a delay circuit that employs the SAD-1024 512 $\times$ 2 CCD register in a differential-in/differential-out configuration. The circuit's input amplifiers, two AD524s, convert single-ended input signals to differential levels that drive the delay line's two inputs. A third instrumentation amp connected to the CCD register's outputs converts delayed differential signals to single-ended waveforms.

The delay line's clock inputs get driven by a pair of CMOS inverters that furnish buffered, complementary clock signals. To satisfy Nyquist's sampling criterion, the clock rate must remain at least twice the highest

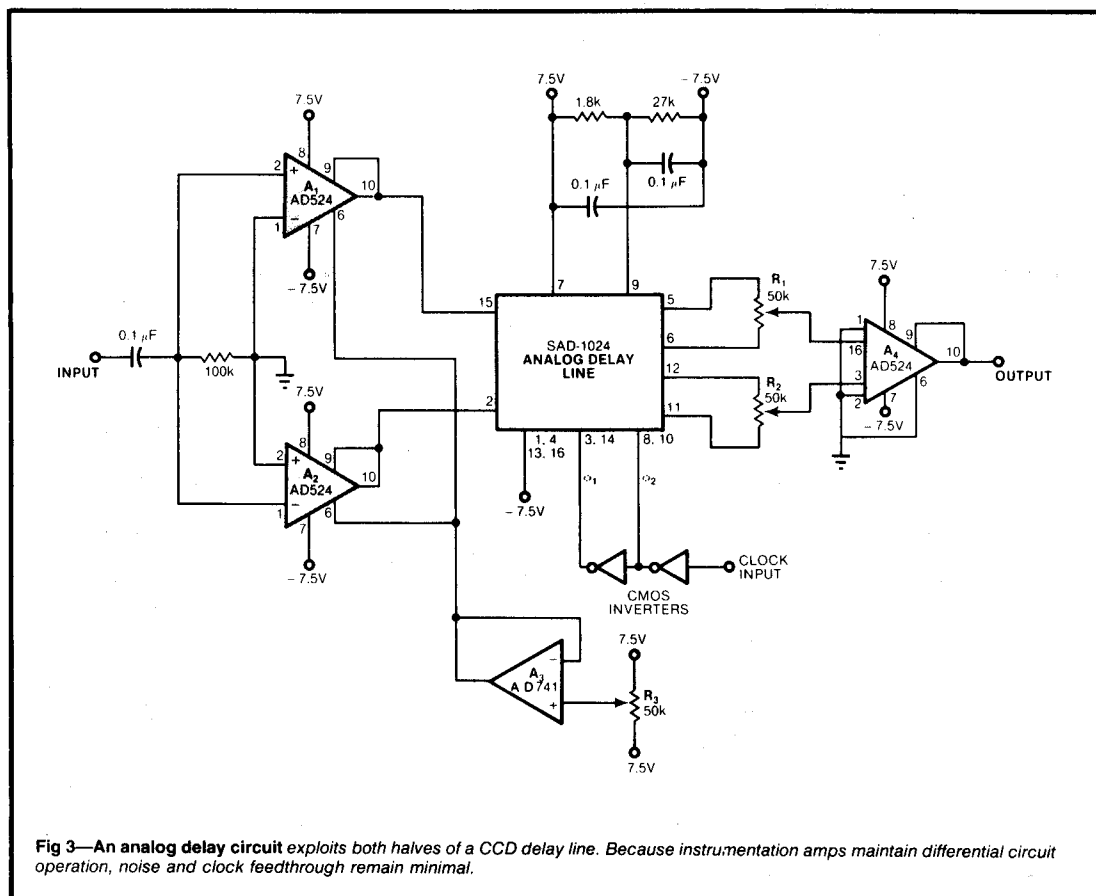

Fig 3—An analog delay circuit exploits both halves of a CCD delay line. Because instrumentation amps maintain differential circuit operation, noise and clock feedthrough remain minimal.

## Internal feedback simplifies circuit design

signal frequency. You can derive the clock from an external VCO and frequency divider.

To ensure minimal clock noise, each of the delay lines' outputs consists of two signals. Potentiometers  $R_1$  and  $R_2$  let you balance these signals' currents and thus maximize clock-noise rejection. The differential, current-summing output configuration further nulls clock feedthrough, resulting in an overall signal-to-noise ratio of 70 dB—a level unattainable using single-ended designs.

As shown, the circuit's input amplifiers exhibit unity gain, but you can configure them for gains to 1000.  $A_3$  and its associated circuitry let you bias the input stages to a level that ensures minimum delay-line harmonic distortion. To trim the circuit, adjust  $R_3$  for the bias level that results in minimum distortion with a 1V rms input signal. When properly adjusted and fed by a 150-kHz clock, the circuit typically operates with 0.2% total harmonic distortion.

### Measuring distortion

You can further exploit instrumentation amps' differential properties to enhance the resolution of distortion-measuring equipment. Typical distortion meters null signal fundamentals by 80 to 100 dB and thus exhibit measurement limits of 0.01 to 0.001%. But by using an instrumentation amp to prenull a device-under-test's (DUT's) output (Fig 4), you can extend a distortion meter's measurement capabilities to 140 dB below fundamental amplitudes. Thus, you can measure distortion as low as 0.00001%.

The prenulling method entails several advantages in addition to greater measurement resolution. First, because an instrumentation amp subtracts signal-source inputs from DUT outputs, test-oscillator errors are cancelled during the measurement process. As a result, you can measure lower distortion levels than most oscillators allow.

In addition, the prenulling method relaxes the dynamic-range requirements normally imposed on distortion meters used for high-resolution tests. The distortion meter processes only signal errors—not fundamentals—so the analyzer need only possess sufficient dynamic range to monitor errors in the instrumentation amp's residual output. And because the test signal is cancelled through subtraction rather than through notch filtering, you can use complex waveforms for intermodulation testing and other harmonic analyses.

In Fig 4's circuit, amplifiers under test drive a load resistor,  $R_L$ . A linear network with a gain of  $1/A$ , where  $A$  equals the amplifier's gain, feeds the voltage across  $R_L$  to one input of the nulling amp. The other instrumentation-amp input serves as a reference port

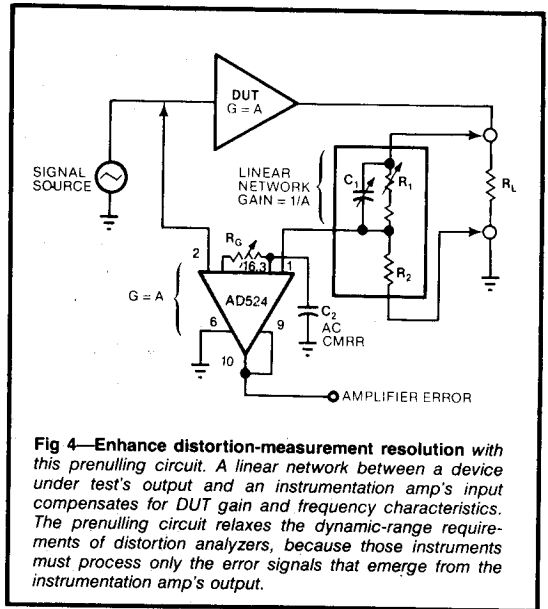

**Fig 4—Enhance distortion-measurement resolution with this prenulling circuit. A linear network between a device under test's output and an instrumentation amp's input compensates for DUT gain and frequency characteristics. The prenulling circuit relaxes the dynamic-range requirements of distortion analyzers, because those instruments must process only the error signals that emerge from the instrumentation amp's output.**

and connects to the DUT's input signal. With the instrumentation amp's gain set to  $A$  (via  $R_G$ ), the nulling circuit's error-output level remains referred to the DUT's output-signal amplitude.

Adjusting the attenuator network proves the most difficult aspect of the nulling circuit's setup procedure. The first—and easiest—step involves adjusting  $R_1$  for dc attenuation equal to  $1+A$ . Then you must trim compensation capacitor  $C_1$  in the same manner that you compensate oscilloscope probes. Time constant  $R_1C_1$  must correspond to the  $-3$ -dB bandwidth of the DUT; otherwise, the instrumentation amp won't fully null high-frequency signal components.

When constructing the attenuator, make certain that  $R_1$  and  $R_2$  are nonreactive and possess thermal- and voltage-nonlinearity coefficients small enough to prevent masking of DUT errors. In addition, you must perform several  $R_1/C_1$  adjustment iterations to ensure optimum nulling.

If you intend to use a meter to display the instrumentation amp's output, you must ensure precise phase tracking between the DUT and the attenuator network;  $1^\circ$  of phase error limits rejection to only 35 dB. If you're feeding a spectrum analyzer, however, you can relax the phase-tracking requirement, so long as residual fundamentals don't overload the analyzer's front end. Fig 5a illustrates a spectrum-analyzer display that shows the results obtained from proper nulling. The fundamental is displayed at a level 106 dB below a 3V rms test signal; the second harmonic,

## Split equalization network improves phono preamp

therefore, is clearly displayed, even at a level 120 dB below the test signal.

Fig 5b shows the results of a prenull-based intermodulation test. In this measurement, 5- and 6-kHz signals are applied simultaneously to the DUT. The analyzer clearly displays the 1- and 11-kHz sum and difference frequencies as well as the 10- and 12-kHz second-harmonic components. Because the instrumentation amp cancels all but a small portion of the test signals, you can use a limited-dynamic-range FFT analyzer to recover output-waveform spectral data, even when harmonic and intermodulation components remain more than 100 dB below test-signal levels.

You can employ a similar difference-amplifier scheme

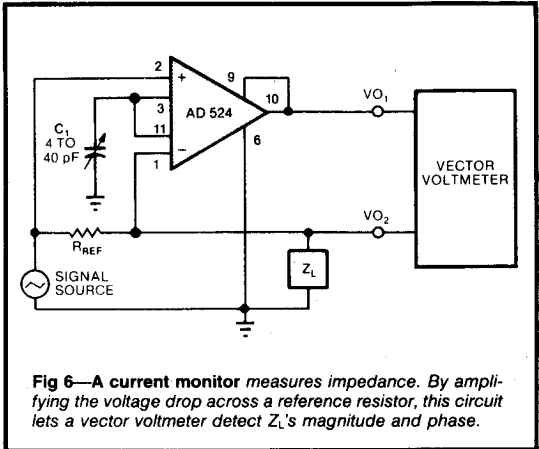
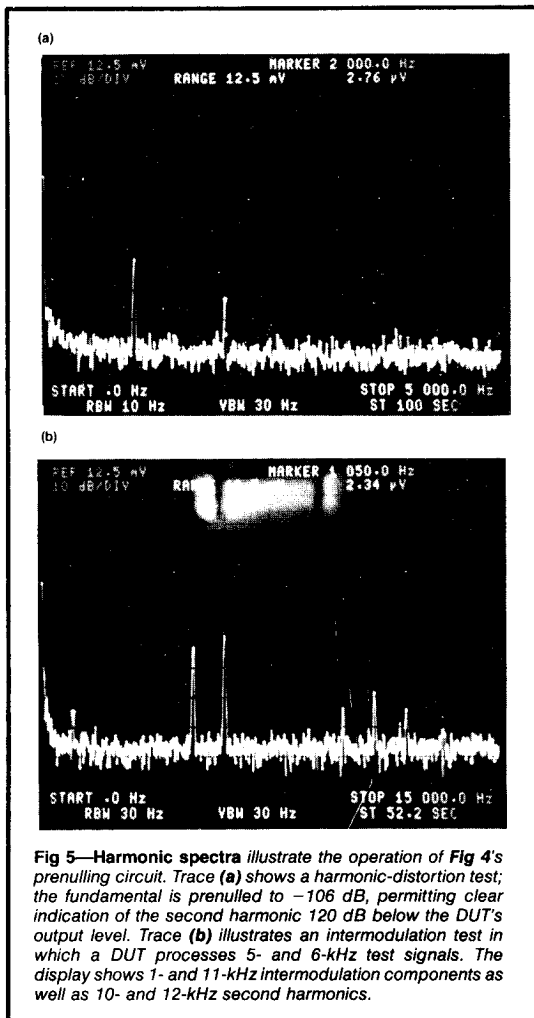

to measure complex impedances. Some instrumentation amps feature very high high-frequency CMRR, trimmable via a single capacitor, so the circuits suit applications involving current sensing on lines with large time-varying components.

In Fig 6's current monitor, for example, a low-impedance sine-wave source feeds a signal to a reference resistor ( $R_{REF}$ ) and one input of an instrumentation amp.  $R_{REF}$  is a precision, nonreactive resistor exhibiting low impedance compared with the network under test ( $Z_L$ ). The instrumentation amp's output equals the voltage across  $R_{REF}$  multiplied by the stage's gain and thus remains proportional to the current through  $Z_L$ . You can trim the circuit for minimum error (maximum CMRR) by shorting  $R_{REF}$  and adjusting  $C_1$  for minimum circuit output.

You can use Fig 6's circuit to measure complex impedances by connecting a vector voltmeter to the instrumentation amp's output and to  $Z_L$ . The vector monitor measures the magnitude and angle of  $V_L \div I_L$  and computes  $R_L = (V_L / I_L) \cos \theta$  and  $X_L = (V_L / I_L) \sin \theta$ .

## Instrumentation amp improves phono preamp

High CMRR also brings advantages to phono-cartridge preamplifiers. Typically, preamps for moving-magnet phono pickups (the cartridges most commonly used in stereo systems) employ op amps with RIAA equalization networks (N) in their feedback loops (Fig 7a). These circuits are quite simple—they employ only one active device—but they impose stringent performance requirements on the op amps they employ. To process low-level signals between 20 Hz and 20 kHz while providing 1-kHz gains of as much as 40 dB, op amps used in conventional phono preamps must exhibit low noise and high speed at unity gain. And to drive complex feedback networks, they must furnish low

## Prenulling circuit ups measurement resolution

output impedance at high frequencies. Most important, single-ended circuits provide poor low-frequency hum rejection.

An alternative phono-preamp approach (Fig 7b), however, exploits instrumentation amps' differential properties and low-input noise to provide excellent signal-to-noise characteristics and equalization-independent gain control. In this circuit, an AD624 instrumentation amp ( $A_1$ ) converts a moving-magnet cartridge's balanced output to a single-ended amplified voltage suiting equalization and further processing.

Two termination resistors ( $R_{TA}$  and  $R_{TB}$ ) provide dc input loading (47 k $\Omega$  typ), and a pair of capacitors ( $C_{TA}$  and  $C_{TB}$ ) furnish cartridge damping (150 pF suffices for most cartridges). The differential network maintains signal balance for maximum hum rejection while ensuring proper cartridge termination. A 4- to 40-pF trimmer or 15-pF fixed capacitor connected to the instrumentation amp's gain terminals increases high-

frequency common-mode rejection. You can further improve the circuit's high-frequency common-mode performance by adjusting the ratio of  $C_{TA}$  to  $C_{TB}$ .

Because most of  $A_1$ 's input current flows through  $R_{TA}$  and  $R_{TB}$ , only the instrumentation amp's offset current flows through the cartridge. And because the AD624's offset current never exceeds 35 nA and typically equals only 10 nA, input-current-induced offset errors remain negligible compared with the instrumentation amp's 250- $\mu$ V input-offset level.

To allow maximum component-choice freedom, Fig 7b's design accomplishes RIAA equalization in two stages. A passive network ( $R_1$  and  $C_1$ ) between  $A_1$  and output buffer  $A_2$  furnishes 75- $\mu$ sec de-emphasis; the responses' 318- and 3180- $\mu$ sec components are generated in  $A_2$ 's feedback loop. This split-network technique results in complete buffering of all equalization components. An alternative equalization technique involves lumping all three RIAA time constants in a single

### The instrumentation amp as op amp

As monolithic instrumentation amps' performance improves, an interesting role reversal occurs: Instrumentation amps are composed of op amps, but they can also serve as op amps. Consider, for example, the nearby figure's precision instrumentation-amp-based op amp. In this circuit, sense and reference resistors connect to the output terminal, thus configuring the instrumentation amp's output amplifier as a Howland current pump (EDN, January 20, pg 85). Because the current pump exhibits very high conductance, the output amplifier operates with considerable gain. Indeed, this gain is bounded only by CMRR restrictions and typically equals 80 dB.

However, the instrumentation-amp-based op amp's total gain exceeds 80 dB when the input amplifiers are connected to the output buffer. With input gain strapped for 100, for example, an op-amp-configured AD524 provides open-loop gain of  $5 \times 10^6$  (134 dB) typ.

In the figure's circuit, closed-

loop gain equals 1000 and -3-dB bandwidth equals 56 kHz. Thus, the amplifier exhibits a gain-bandwidth product of 56 MHz. Such wide bandwidth, coupled with the instrumentation amp's low noise and high stability, results in performance typically unattainable in conventional IC op amps. As an added advantage over conventional op amps, the circuit's damping characteristics depend only on the setting of one resistor ( $R_G$ ).

Such instrumentation-amp-based op amps prove useful in applications requiring closed-loop gains to 100,000 over wide bandwidths. An AD524, for example, provides gain-bandwidth products as high as 1 GHz when its input amplifiers are set for gains of 1000. Note, however, that instrumentation-amp-based op amps remain most effective at high gains; excess front-end phase results in instability at very low closed-loop gains.

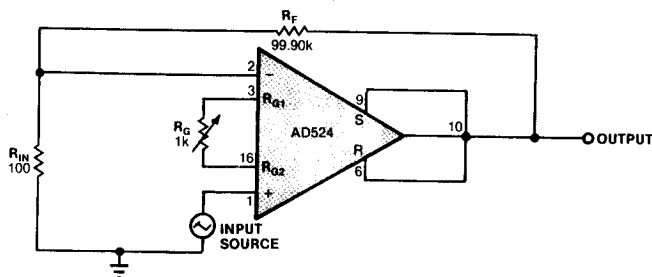

An instrumentation amp acts like an op amp when sense and reference resistors connect to circuit outputs. The dual-feedback arrangement configures the instrumentation amp's output amplifier as a Howland current pump and thus results in high open-loop gain

# A unity-gain buffer overcomes drive limitations

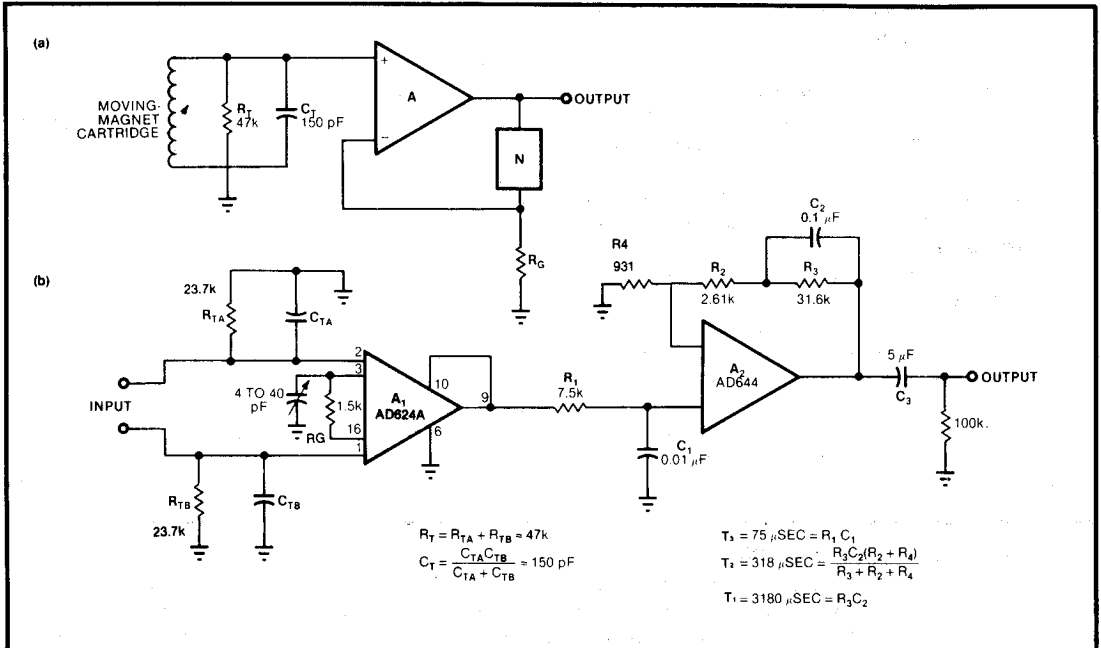

**Fig 7—Conventional phono preamps (a) employ a single RIAA-equalization network (N) in an op amp's feedback loop. Although such circuits are extremely simple, they impose undue demands on op-amp performance. A better circuit (b) uses an instrumentation amp to buffer cartridge outputs. The instrumentation amp's high CMRR results in hum rejection to 100 dB.**

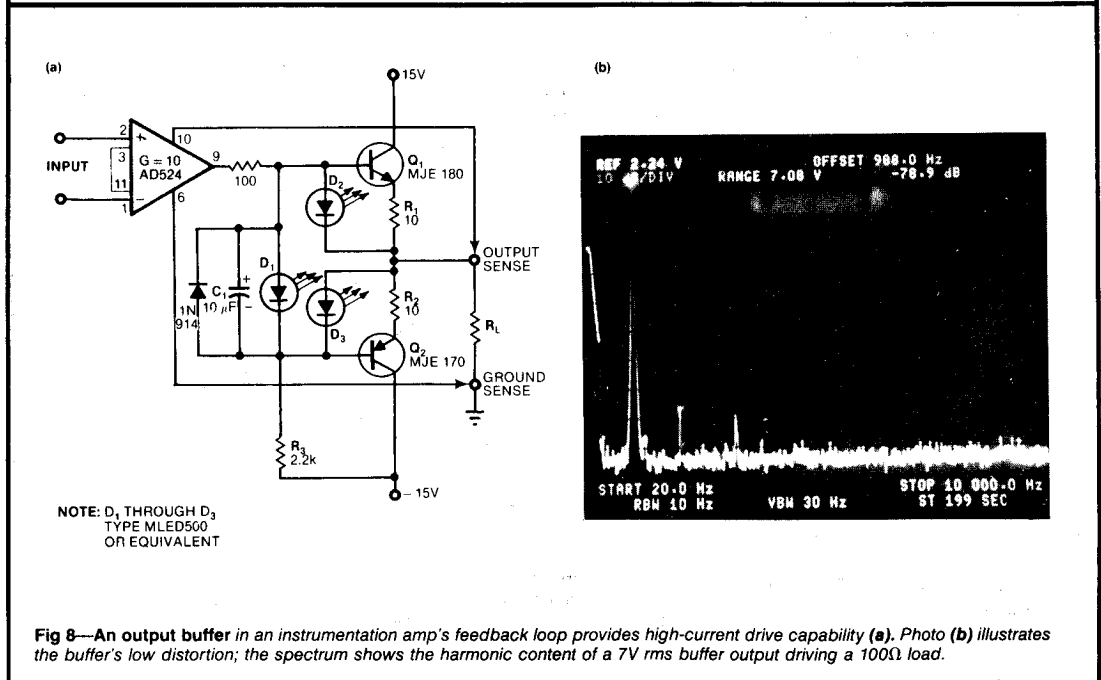

**Fig 8—An output buffer in an instrumentation amp's feedback loop provides high-current drive capability (a). Photo (b) illustrates the buffer's low distortion; the spectrum shows the harmonic content of a 7V rms buffer output driving a 100Ω load.**



network between  $A_1$  and  $A_2$  (Ref 2), but such a scheme results in greater output noise than does the split-equalization method.

In Fig 7b's circuit, lowest noise results when  $A_1$  operates with high gain; greatest overload immunity results when  $A_1$  exhibits relatively little gain. Therefore, you must select the input-stage gain that leads to the best compromise between two conflicting performance attributes. Typically, the best compromise results when  $A_1$ 's gain equals approximately 20;  $A_2$  then must provide the remainder of the network's gain. In Fig 7b's design,  $A_1$  operates with a gain of 28 and  $A_2$  exhibits a dc gain of 38. Total dc gain thus equals 1064 or approximately 60 dB.

In general, the phono preamp's dc gain equals

$$G_{DC} = (1 + 40k/R_G)(1 + (R_2 + R_3)/R_4),$$

and RIAA-equalized 1-kHz gain equals

$$G_{1k} = 0.101G_{DC}.$$

The constant 0.101 represents the ratio between dc and 1-kHz gains as set forth by the RIAA equalization standard. In Fig 7b's circuit, 1-kHz gain equals approximately 40 dB. You can vary the circuit's gain without affecting its equalization characteristics by adjusting  $R_G$ 's value. Similarly, you can alter the circuit's response—to adapt it for tape-head applications, for example—by selecting appropriate values for  $R_1$  through  $R_3$ ,  $C_1$  and  $C_2$ .

As shown, with 40-dB midband gain, the phono preamp furnishes an 80-dB signal-to-noise ratio referred to a 1V output. Low-frequency CMRR equals 100 dB min. Maximum response accuracy and stability result when all equalization-network resistors are metal-film types and all capacitors employ polystyrene or polypropylene dielectrics.

Frequently, instrumentation amps must provide output currents exceeding 5 mA while maintaining full specified accuracy. Most IC instrumentation amps are specified to drive 5 mA into 2-k $\Omega$  loads, but their 100 $\Omega$  typ open-loop output impedances restrict higher current operation. By placing a unity-gain buffer inside an instrumentation amp's feedback loop, however, you can overcome circuit drive limitations.

Fig 8a illustrates a buffered instrumentation-amp circuit that drives load impedances as low as 150 $\Omega$  and delivers as much as 75 mA of output current. The circuit employs a complementary pair of 3A/40V power transistors ( $Q_1$  and  $Q_2$ ) that get forward-biased by LED  $D_1$ . Because of  $D_1$ 's bias voltage,  $R_1$  and  $R_2$  drop approximately 140 mV each, resulting in an output quiescent current of approximately 15 mA with the component values shown. The 15-mA bias level proves

sufficient to prevent output-stage crossover distortion. Two additional LEDs ( $D_2$  and  $D_3$ ) serve as voltage clamps, limiting the current through  $Q_1$  and  $Q_2$  to approximately 100 mA. These LEDs also act as overload indicators.

When constructing Fig 8a's circuit, observe several precautions. First, for maximum linearity, select  $R_3$  so that it forces  $A_1$ 's output stage into Class A operation. You must also sense output voltages from the output terminal, not from internal circuit nodes. In addition, connect the load's common terminal to ground via its own power-supply connection. Otherwise, load currents might perturb the circuit's analog ground. Finally, to prevent high-frequency oscillations, mount bypass capacitors as close as possible to the output transistors' collectors.

## References

1. Wurcer, S A, and Kitchen, C, "Stacked amplifiers lower noise," *EDN*, October 13, 1982, pg 184.
2. Jung, W, "Topology considerations for RIAA phono preamplifiers," 67th Audio Engineering Society Convention, November 1982, Reprint No 1719.
3. Wurcer, S A, and Counts, L W, "A programmable instrumentation amplifier for 12-bit-resolution systems," *IEEE Journal of Solid State Circuits*, Vol SC-17, No 6, December 1982, pgs 1102-1111.
4. Jung, W, *Audio IC Op Amp Applications (second edition)*, Howard W Sams and Co Inc, Indianapolis, IN, 1978.

