

Using the **AD8599** Op Amp as an Ultralow Distortion Driver for the **AD7999** 4-Channel, 8-Bit ADC

CIRCUIT FUNCTION AND BENEFITS

The circuit described in this document provides an ultralow distortion driver circuit for the **AD7999** 8-bit, 4-channel ADC, which is designed to achieve optimum ac and dc performance. The circuit uses the ultralow distortion, ultralow noise **AD8599** dual-supply op amp and ultrahigh precision **AD780** band gap voltage reference to ensure that the maximum **AD7999** performance is achieved, by providing a low impedance driver with adequate settling time and a highly accurate reference voltage. The **AD8599** is a dual operational amplifier that operates with supplies from ± 4.5 V to ± 18 V. The **AD7999** has an I²C-compatible serial interface and is offered in an 8-lead SOT-23 package.

CIRCUIT DESCRIPTION

Table 1. Devices Connected/Referenced

Product	Description
AD7999	4-channel, 8-bit ADC
AD8599	Dual, ultralow distortion, ultralow noise op amp
AD780	Ultrahigh precision band gap voltage reference

It is always recommended to buffer analog input signals before applying them to ADCs with switched capacitor inputs such as the **AD7999**. This is particularly important in applications where the signal source has high source impedance and where low distortion and high signal-to-noise-ratio is important. The circuit illustrated in Figure 1 shows how the **AD8599**, an ideal choice for high accuracy designs, can be used to buffer the analog input channels.

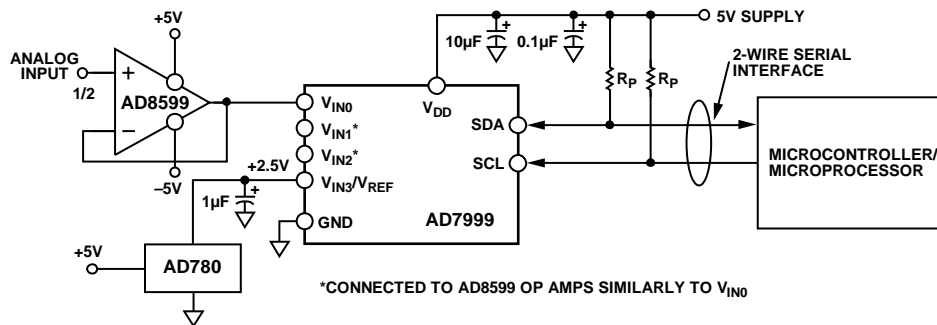

Figure 1. **AD7999** ADC with the **AD8599** Low Distortion Driver and **AD780** Ultrahigh Precision Reference
(Simplified Schematic: Decoupling and All Connections Not Shown)

08484-001

The [AD7999](#) can be operated as a 4-channel input device using V_{DD} as a reference (the input voltage range is 0 V to V_{DD}) or as a 3-channel input device with the fourth channel used as an external reference input, V_{REF} (the input range is 0 V to V_{REF}). These options are programmable via the I²C-compatible interface. The [AD780](#) is a 2.5 V/3 V ultrahigh precision, band gap voltage reference and is recommended for use with [AD7999](#). A 1 μ F decoupling capacitor is recommended on the V_{IN3}/V_{REF} signal for best performance.

Care must be taken to ensure that the analog input signal to the ADC does not exceed the supply rails by more than 300 mV. If the signal does exceed this level, the internal ESD protection diodes become forward-biased and start conducting current into the substrate. Each diode can conduct a maximum current of 10 mA without causing irreversible damage to the part. The [MT-036 Tutorial](#) discusses methods to protect the input circuits of op amps and ADCs against such damage.

In addition, the circuit must be constructed on a multilayer PC board with a large area ground plane. Proper layout, grounding, and decoupling techniques must be used to achieve optimum performance (see [MT-031 Tutorial](#), [MT-101 Tutorial](#), and the [AD7999 evaluation board](#) layout).

COMMON VARIATIONS

If single-supply op amp operation is required for buffering the input signal, the [AD8605](#) is a suitable choice. Note that the output of the [AD8605](#) operating on a single +5 V supply can only go to approximately 20 mV above ground; therefore, the [AD7999](#) input range from 0 V to +20 mV cannot be exercised (see [MT-035 Tutorial](#)).

The [AD7995](#) can accept a reference input voltage from 1.2 V to V_{DD} ; therefore, different voltage reference sources can be used.

LEARN MORE

[MT-031 Tutorial, Grounding Data Converters and Solving the Mystery of "AGND" and "DGND."](#) Analog Devices.

[MT-035 Tutorial, Op Amp Inputs, Outputs, Single-Supply, and Rail-to-Rail Issues.](#) Analog Devices.

[MT-036 Tutorial, Op Amp Output Phase-Reversal and Input Over-Voltage Protection.](#) Analog Devices.

[MT-101 Tutorial, Decoupling Techniques.](#) Analog Devices.

Data Sheets and Evaluation Boards

[AD7999 Data Sheet.](#)

[AD8599 Data Sheet.](#)

[AD8605 Data Sheet.](#)

[AD780 Data Sheet.](#)

[AD7999 Evaluation Board.](#)

REVISION HISTORY

5/13—Rev. A to Rev. B

Changed Document Title from CN-0045 to AN-1233 Universal

9/09—Rev. 0 to Rev. A

Updated Format..... Universal

10/08—Revision 0: Initial Version