

## Aperture Uncertainty and ADC System Performance

by Brad Brannon and Allen Barlow

### APERTURE UNCERTAINTY

Aperture uncertainty is a key ADC concern when performing IF sampling. The terms aperture jitter and aperture uncertainty are synonymous and are frequently interchanged in the literature. Aperture uncertainty is the sample-to-sample variation in the encoding process. It has three distinct effects on system performance. First, it can increase system noise. Second, it can contribute to the uncertainty in the actual phase of the sampled signal itself giving rise to increases in error vector magnitude. Third, it can heighten intersymbol interference (ISI). However, in typical communications applications, an aperture uncertainty that is sufficiently small to meet system noise constraints results in negligible impact on phase uncertainty and ISI. For example, consider the case of sampling an IF of 250 MHz. At that speed, even 1 ps of aperture jitter can limit any ADC's SNR to only 56 dB, while for the same conditions, the phase uncertainty error is only 0.09 degrees rms based on a 4 ns period. This is quite acceptable even for a demanding specification such as GSM. The focus of this analysis is, therefore, on overall noise contribution due to aperture uncertainty.

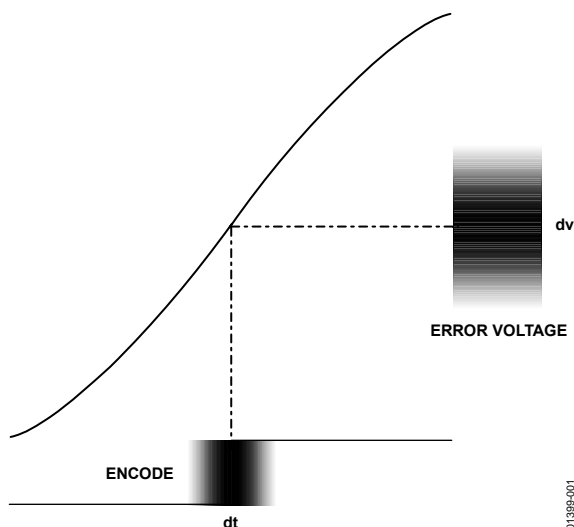

Figure 1. RMS Jitter vs. RMS Noise

Figure 1 illustrates how an error in the sampling instant results in an error in the sampled voltage. Mathematically, the magnitude of the sampled voltage error is defined by the time derivative of the signal function. Consider a sine wave input signal

$$v(t) = A \sin(2\pi ft) \quad (1)$$

The derivative is

$$\frac{dv(t)}{dt} = A 2\pi f \cos(2\pi ft) \quad (2)$$

The maximum error occurs when the cosine function equals 1, that is, at  $t = 0$ .

$$\left. \frac{dv(t)}{dt} \right|_{\max} = A 2\pi f \quad (3)$$

We see from Figure 1 that  $dv$  is the error in the sampled voltage corresponding to the jitter  $dt$ . For conceptual clarity, if we relabel  $dv$  as  $V_{err}$  and  $dt$  as  $t_a$  (aperture error) and rearrange the factors, we get

$$V_{err} = A 2\pi f t_a \quad (4)$$

If  $t_a$  is given as an rms value, the derived  $V_{err}$  is also rms. Although this is the error at maximum input slew and represents an upper bound rather than a nominal, this simple model proves surprisingly accurate and useful for estimating the degradation in SNR as a function of sample clock jitter.

### JITTER AND SNR

As Equation 4 indicates, the error in the sampled voltage increases linearly with input frequency, so at high frequencies, for example, in IF sampled receiver applications, clock purity becomes extremely important. Sampling is a mixing operation: the input signal is multiplied by a local oscillator or in this case, a sampling clock. Because multiplication in time is convolution in the frequency domain, the spectrum of the sample clock is convolved with the spectrum of the input signal. Considering that aperture uncertainty is wideband noise on the clock, it shows up as wideband noise in the sampled spectrum, periodic and repeated around the sample rate.

Because ADC encode inputs have very high bandwidth, the effects of clock input noise can extend out many times the sample rate itself and alias back into the baseband of the converter. Therefore, this wideband noise degrades the noise floor performance of the ADC. Consider a sinusoidal input signal of amplitude A. Utilizing Equation 4, the SNR for an ADC limited by aperture uncertainty is

$$SNR = 20 \log \frac{A}{V_{err}} = -20 \log(2\pi f t_a) \quad (5)$$

Equation 5 illustrates why systems that require high dynamic range and high analog input frequencies also require a low jitter encode source. For an analog input of 200 MHz and only 300 femtoseconds rms clock jitter, SNR is limited to only 68.5 dB, well below the level commonly achieved at lower speeds by 12-bit converters. Note in Equation 5 that the jitter limit of SNR is independent of the converter resolution. (For the case just mentioned, a 14-bit converter would do no better.)

Aperture jitter is not always the performance limiter. Equation 6 shows its effect in superposition with other noise sources. The first term in the brackets is the jitter from Equation 5. To that, we must add terms for quantization noise, DNL, and thermal noise. For other analytic purposes, each of these could be broken out separately, but for simplicity in isolating the effect of jitter, we combine them here in a single additional term.

$$SNR = -20 \log \left[ \left( 2\pi f t_a \right)^2 + \left( \frac{1 + \varepsilon}{2^N} \right)^2 \right]^{1/2} \quad (6)$$

where:

$f$  = analog input frequency.

$t_a$  = aperture uncertainty (jitter).

$\varepsilon$  = “composite rms DNL” in LSBs, including thermal noise.

$N$  = number of bits.

This simple equation provides considerable insight into the noise performance of a data converter.

## MEASURING SUBPICOSECOND JITTER

Aperture uncertainty is readily determined by examining SNR without harmonics as a function of analog input frequency. Two measurements are required for the calculation. The first measurement is done at a sufficiently low analog input frequency that the effects of aperture uncertainty are negligible. Since jitter is negligible, Equation 6 can be simplified and rearranged to solve for  $\varepsilon$ , the “composite DNL.”

$$\varepsilon = 2^N \times 10^{\frac{-SNR}{20}} - 1 \quad (7)$$

Here, SNR is the low frequency value just measured.

Next, an FFT is done at high (IF) frequency. The high frequency chosen should be as high as possible. Again, the SNR value without harmonics is measured. This time jitter is a contributor to noise and solving Equation 6 for  $t_a$  yields

$$t_a = \frac{\sqrt{\left( 10^{\frac{-SNR}{20}} \right)^2 - \left( \frac{1 + \varepsilon}{2^N} \right)^2}}{2\pi f} \quad (8)$$

where:

SNR = the high frequency SNR just measured

$\varepsilon$  = the value determined in the low frequency measurement.

## EXAMPLE: JITTER AND THE AD9246

The example shown here utilizes the AD9246 evaluation board, a 14-bit, 125 MSPS ADC. An external clock oscillator such as a Wenzel Sprinter or Ultra-Low Noise provides a suitable encode source. A mainstream RF synthesizer from Rohde & Schwarz or Agilent can be used for the analog source. Typically, these generators have insufficient phase noise performance for use as the encode source. For more information about configuring Analog Devices evaluation boards, please consult the individual product data sheet.

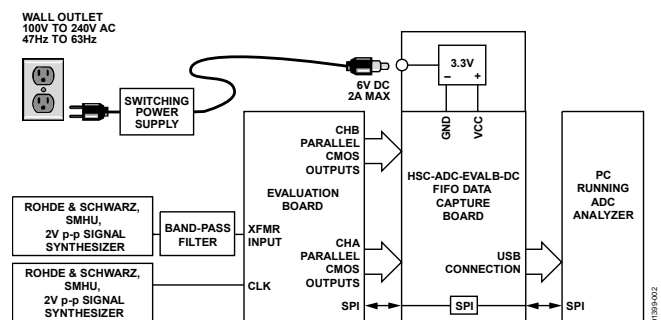

Figure 2. Aperture Uncertainty Measurement Setup with AD9246 Customer Evaluation Board

Figure 3 is a 5 average, 64 K FFT of the AD9246 sampling a 2.3 MHz sine wave at 125 MSPS. Analog Devices’ ADC Analyzer™ Software ([www.analog.com/fifo](http://www.analog.com/fifo)) collects and processes the data to report SNR without harmonics. From the plots, the SNR is 72.05 dBFS.

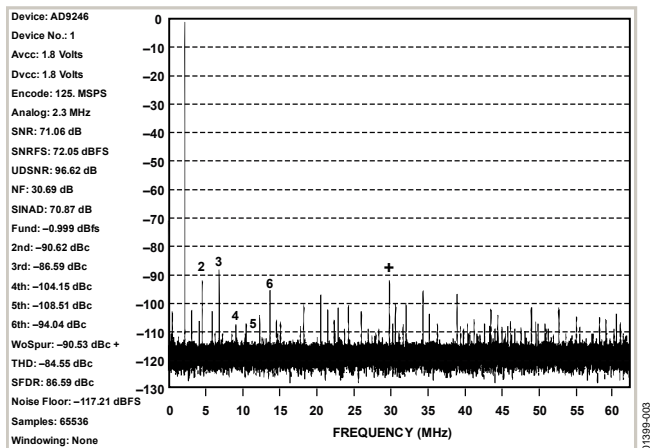

Figure 3. 2.3 MHz FFT

Using this value for SNR in Equation 7 gives a “composite DNL ( $\epsilon$ )” for this converter of 3.09 LSB.

Next, the degradation in SNR as a function of analog input frequency is found. Figure 4 shows data from the same setup and clock, but using an analog input frequency of 201 MHz. Here, the noise floor has risen and the resulting SNR is 69.05 dBFS.

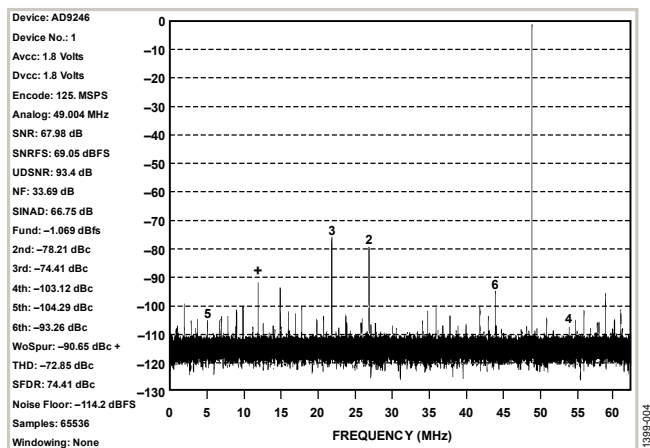

Figure 4. 201 MHz FFT

Using this SNR and the previous solution for  $\epsilon$ , Equation 8 gives

$$t_a = \frac{\sqrt{\left(10^{\frac{-69.05}{20}}\right)^2 - \left(\frac{1 + 3.092}{2^{14}}\right)^2}}{2\pi \cdot 201 \times 10^6} = 197 \text{ fs rms} \quad (9)$$

This value, 197 fs, is the combined aperture uncertainty for the AD9246 plus the clock oscillator. Since total noise squared is the sum of the squares of individual contributors, the jitter of the ADC itself is readily determined if the jitter of the source clock is known. Here a Wenzel ULN clock oscillator with about 50 fs jitter is used, giving a jitter for the ADC of about 190 fs. These simple measurements confirm that it is possible to measure very small aperture uncertainty numbers using readily available hardware and simple numeric calculations.

Figure 5 overlays plots of Equation 5 for various jitter values (the sloped lines) with ideal, quantization noise limited performance at various resolutions (the horizontal lines), and is a useful guide for quickly determining jitter limits based on analog input frequency and SNR requirements.

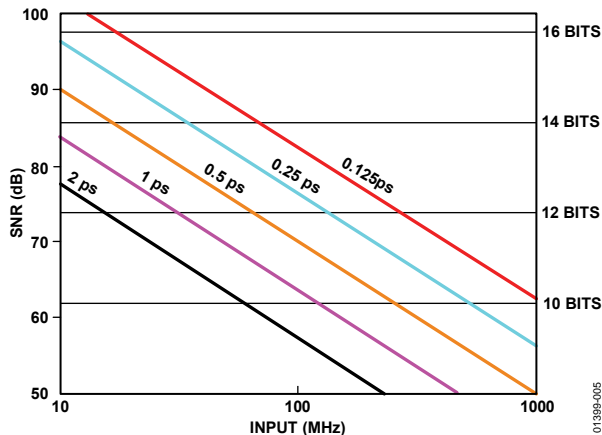

Figure 5. Signal-to-Noise Ratio Due to Aperture Jitter

### CLOCK DISTRIBUTION

System clocks commonly must be distributed to multiple converters, and additionally to the FPGAs, ASICs, and DSPs included in the signal chain. There are several ways to distribute clocks with the low jitter demanded by the converters.

If the sample clock is generated as a sine wave, it can be distributed using power dividers and delivered to the ADC with a transformer as shown in Figure 6. This solution is simple and works well for many applications, especially in situations involving single-ended to differential conversion.

However, more often than not the clock is a logic signal sourced directly from a PLL, VCO, or VCXO. In these cases, it is advantageous to use logic gates to fan out the signal and to drive the data converters. Table 1 summarizes the typical jitter that can be achieved with a variety of logic families. It should be noted that many of the older families, and even current FPGAs, cannot deliver acceptable performance. Some newer, high-speed devices do provide acceptable jitter and have the ability to translate single-ended signals into differential signals as shown in Figure 7.

Table 1.

Gate Type	Jitter
FPGA <sup>1</sup>	33 to 50 ps
74LS00	4.94 ps
74HCT00	2.20 ps
74ACT00	0.99 ps
MC100EL16 (PECL)	0.70 ps
AD9510 Clock Synthesis and Distribution	0.22 ps
NBSG16 (Reduced Swing ECL)	0.20 ps

<sup>1</sup> Does not include the jitter introduced by input structure or internal routing gates, or the jitter associated with the use of internal DLL/PLL structures. Based on product data sheet peak-to-peak values ranging from  $\pm 100$  ps to  $\pm 300$  ps peak.

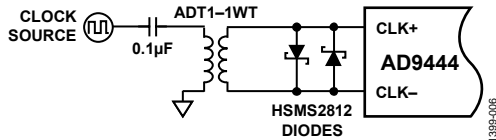

Figure 6. Distribution and Differential Encode Options

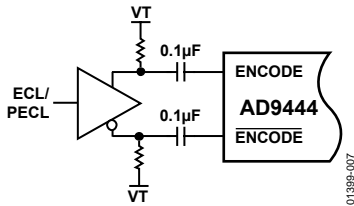

Figure 7. Active Differential Drive Circuit

Clock trees employing cascaded gates are commonly used in digital circuits (see Figure 8), but jitter accumulates as the clock progresses down the tree.

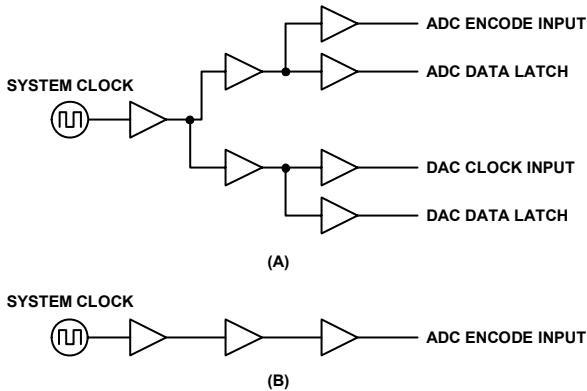

Figure 8. Clock Distribution Chains

In a cascade of just three NBSG16 gates (one of the better performers), the cumulative rms jitter increases to 350 fs, which is a significant impact on system performance of an IF sampling system. It is better to avoid conventional clock trees altogether, and instead, approach clock generation and distribution as a system level function.

Devices such as the AD9510 have optimized the clock paths to minimize total rms noise. By comparing Figure 8 and Figure 9, it is clear that the AD9510 offers the same function for clock distribution as that in Figure 8, but with an additive jitter of only 220 fs. In addition, this part includes an ultra low noise PLL similar to the ADF4106 that allows complete clock cleanup, synthesis, and distribution in a single package.

In addition, the AD9510 includes many other features not available in discrete logic such as selectable output types (LVDS, PECL, and CMOS) and programmable fine delays. Figure 10 shows how the AD9510 can be used in a typical low jitter solution.

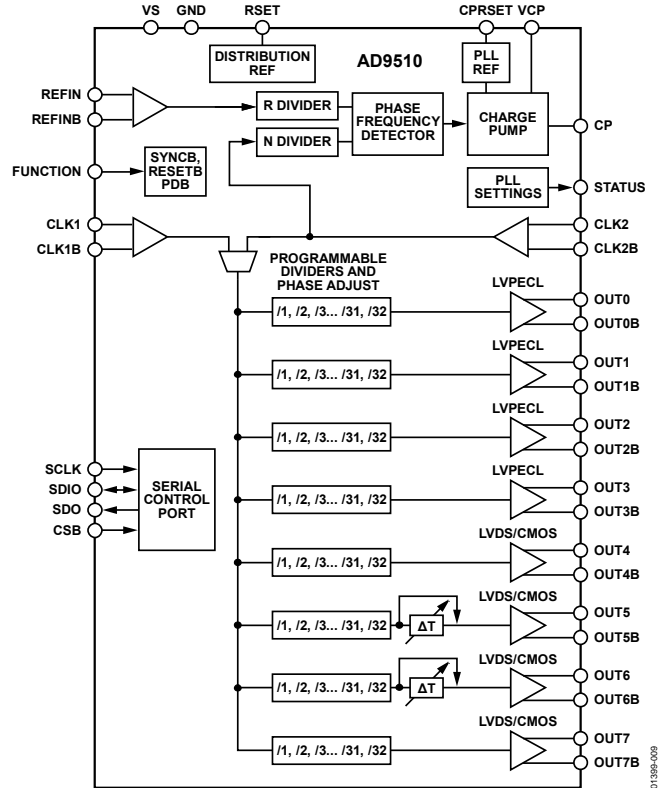

Figure 9. AD9510 Clock Synthesis and Distribution

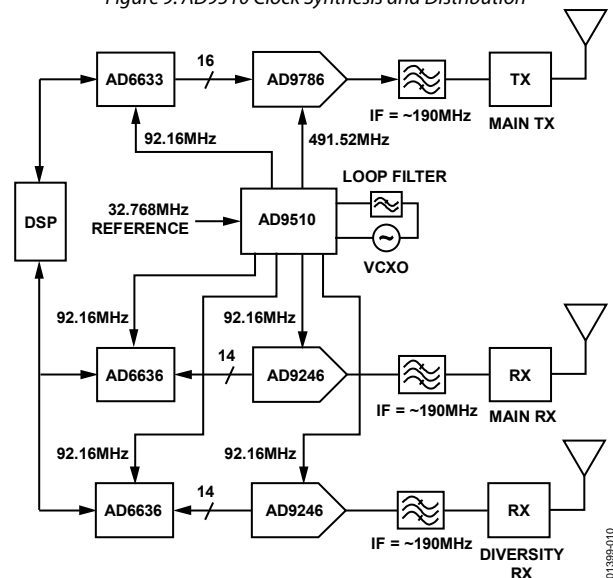

Figure 10. Typical Clock Distribution Application