

Circuits from the Lab™
Reference Circuits

Circuits from the Lab™ reference circuits are engineered and tested for quick and easy system integration to help solve today's analog, mixed-signal, and RF design challenges. For more information and/or support, visit www.analog.com/CN0307.

Devices Connected/Referenced	
AD7625	16-Bit, 6 MSPS, PulSAR, Differential ADC
ADA4897-1/ADA4897-2	Low Power, Low Noise, Single/Dual Amplifier
ADR434	Ultralow Noise XFET Voltage Reference with Current Sink and Source Capability
AD8031/AD8032	2.7 V, 800 μ A, 80 MHz Single/Dual Rail-to-Rail I/O Amplifier

A 16-Bit, 6 MSPS SAR ADC System with Low Power Input Drivers and Reference Optimized for Multiplexed Applications

EVALUATION AND DESIGN SUPPORT

Design and Integration Files

[Schematics](#), [Layout Files](#), [Bill of Materials](#)

CIRCUIT FUNCTION AND BENEFITS

The circuit in Figure 1 is a 16-bit, 6 MSPS, successive approximation (SAR) analog-to-digital converter (ADC) and differential-to-differential driver combination optimized for low noise (signal-to-noise ratio (SNR) = 88.6 dB) and low distortion (total harmonic

distortion (THD) = -110 dBc) at low power. The circuit is ideal for high performance multiplexed data acquisition systems, such as portable digital x-ray systems and security scanners, because the SAR architecture can sample without the latency or pipeline delay typically incurred with pipeline ADCs. The 6 MSPS sampling rate allows fast sampling of multiple channels, and the ADC has true 16-bit dc linearity performance and a serial low voltage differential signaling (LVDS) interface for low pin count and low digital noise.

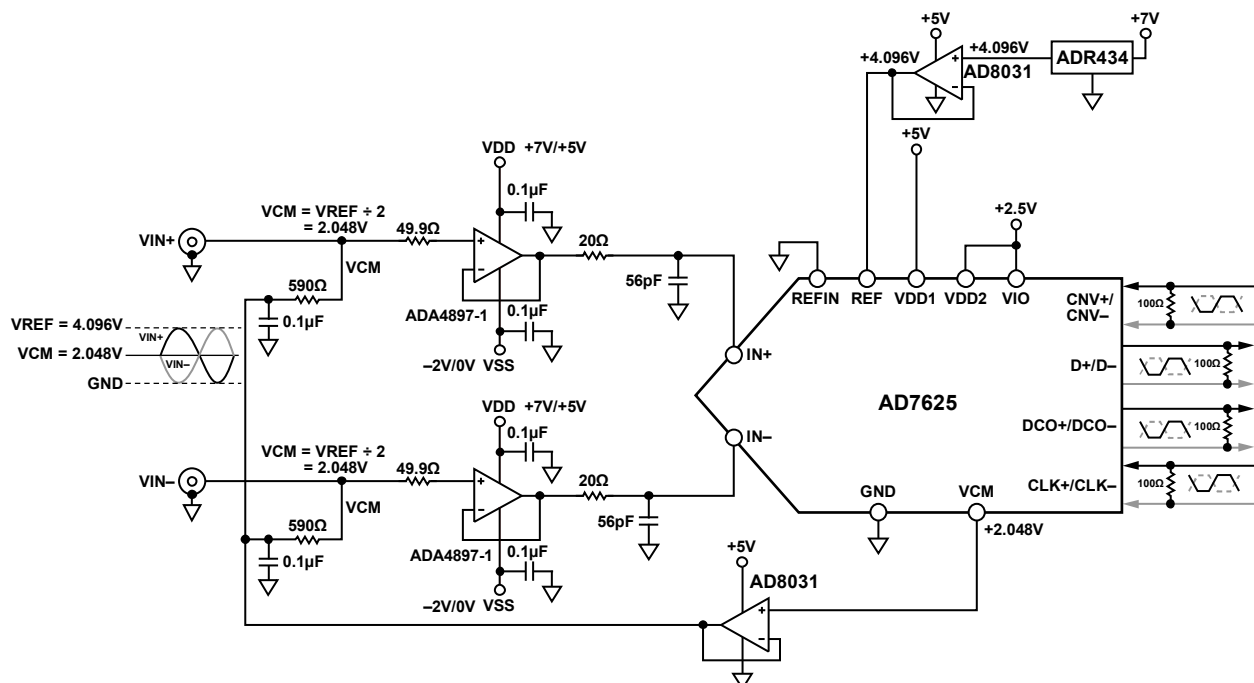

Figure 1. The [ADA4897-1](#) Driving the [AD7625](#) (All Connections and Decoupling Not Shown)

11130-001

Rev. A

Circuits from the Lab™ circuits from Analog Devices have been designed and built by Analog Devices engineers. Standard engineering practices have been employed in the design and construction of each circuit, and their function and performance have been tested and verified in a lab environment at room temperature. However, you are solely responsible for testing the circuit and determining its suitability and applicability for your use and application. Accordingly, in no event shall Analog Devices be liable for direct, indirect, special, incidental, consequential or punitive damages due to any cause whatsoever connected to the use of any Circuits from the Lab circuits. (Continued on last page)

The driver uses two low noise ($1 \text{ nV}/\sqrt{\text{Hz}}$) [ADA4897-1](#) op amps that maintain the dynamic performance of the [AD7625](#) ADC at low power levels (3 mA per amplifier). The fast settling time (45 ns to 0.1%) of [ADA4897-1](#) makes them ideal for multiplexed applications.

This combination offers industry-leading dynamic performance at low power in a small board area with the [AD7625](#) in a 5 mm × 5 mm, 32-lead LFCSP; the [ADA4897-1](#) in an 8-lead SOIC; and the [AD8031](#) in a 5-lead SOT-23 package.

CIRCUIT DESCRIPTION

The [ADA4897-1](#) has low distortion (−93 dB spurious-free dynamic range (SFDR) at 1 MHz), a fast settling time (36 ns to 0.1%), and high bandwidth (230 MHz, −3 dB, $G = 1$). Both [ADA4897-1](#) drivers are configured with a gain of 1. The single-pole 142 MHz low-pass RC filter, using a 20 Ω resistor and 56 pF capacitor, is placed between each of the drivers and the ADC. This filter limits the output noise of the op amp at the inputs of the [AD7625](#) and provides some attenuation of the out-of-band harmonics.

The common-mode voltage at the output of the [ADA4897-1](#) is set by buffering the V_{CM} output voltage (nominally 2.048 V) of the [AD7625](#) using the [AD8031](#) configured as a unity-gain buffer. The common-mode bias voltage is applied to the inputs through the 590 Ω series resistors. The [AD8031](#) is ideal for driving the common-mode voltage because of its low output impedance and fast settling from transient currents.

The [AD7625](#) achieves industry breakthrough dynamic performance of 92 dB SNR at 6 MSPS with a 16-bit (1 LSB) integral nonlinearity (INL) performance using an LVDS interface. The [ADR434](#) voltage reference (4.096 V) is a low noise, high accuracy XFET reference with low temperature drift. It can source up to 30 mA of output current and sink up to 20 mA.

The [ADR434](#) is available in either an 8-lead MSOP or an 8-lead, narrow SOIC package. An [AD8031](#) op amp isolates the [ADR434](#) output from the reference input of the [AD7625](#) and provides low impedance and fast settling to the transient current on the REF input.

The dual driver requires only 54 mW, and when added to the ADC power of 135 mW, and the reference and reference buffer power of 12 mW, yields a total power of only 201 mW for the entire circuit.

The circuit uses supplies of +7 V and −2 V for the input of the [ADA4897-1](#) drivers to minimize power dissipation and to achieve the optimum system distortion performance. The [ADA4897-1](#) output stage is rail-to-rail and swings between 150 mV and 4.85 V when operating on a single 5 V supply. However, the additional 2 V headroom at each end of the range provides lower distortion.

Figure 2 shows the ac performance of the circuit using +7 V and −2 V supplies for the input stage. The SNR = 88.6 dB, THD = −110.7 dB, with a 20 kHz input signal 0.6 dB below full scale (93% full scale).

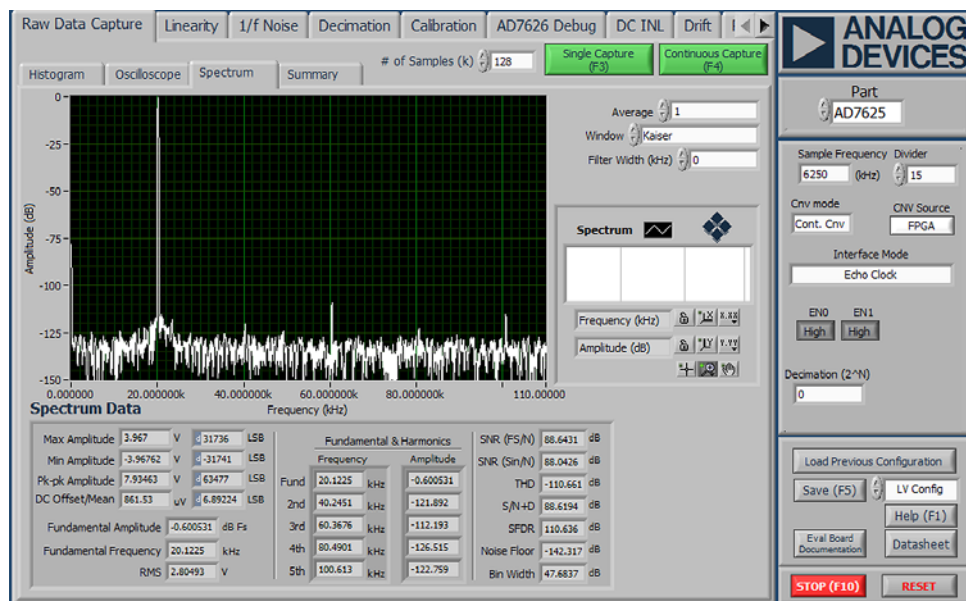

Figure 2. [AD7625](#) and [ADA4897-1](#) in Dual Supply Operation (+7 V, −2 V), SNR = 88.6 dB, THD = −110.7 dB, Fundamental Amplitude = −0.6 dB of Full Scale

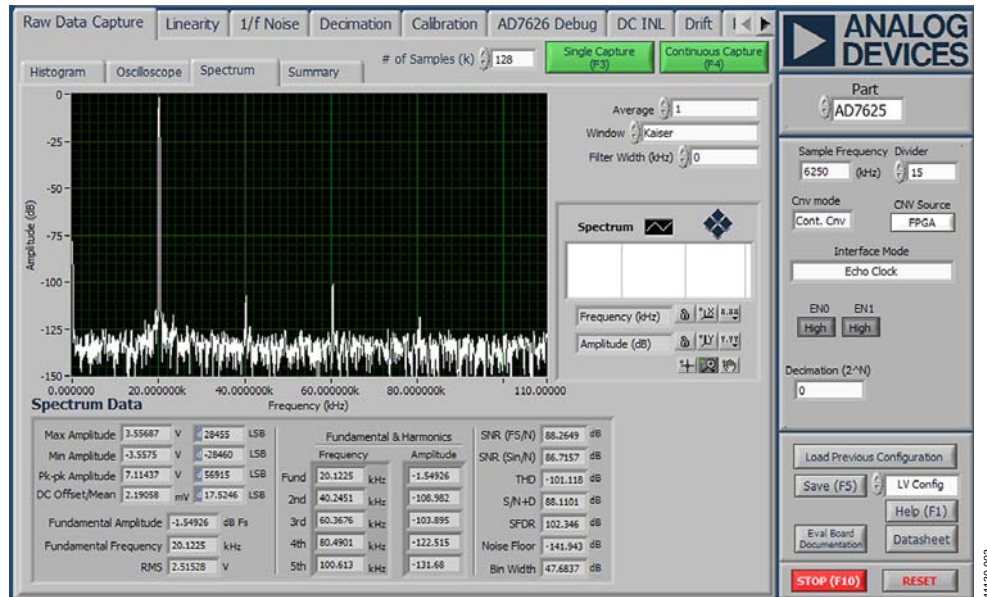

Figure 3. AD7625 and ADA4897-1 in Single Supply Operation (5 V), SNR = 86.7 dB, THD = -101.1 dB, Fundamental Amplitude = -1.55 dB of Full Scale

Figure 3 shows the ac performance of the circuit using a single 5 V supply for the input stage. The SNR = 86.7 dB, THD = -101.1 dB, with a 20 kHz input signal 1.55 dB below full scale (84% full scale).

The data shows an approximate 1.9 dB degradation in SNR and a 9.6 dB degradation in THD due to reducing the supply voltage from -2 V, +7 V to 0 V, +5 V.

The single supply configuration is useful for the users who do not have dual supplies in their system but still must achieve high performance.

COMMON VARIATIONS

The AD7625 has an integrated internal reference as well as two provisions for external references if system requirements dictate. The reference voltage can be generated by applying the ADR3412 reference (1.2 V) output to the REFIN pin, which is amplified internally by the on-chip reference buffer to the correct ADC reference value of 4.096 V. The ADR3412 can be supplied by the same 5 V analog rail used for the AD7625 and also make use of the on-chip reference buffer.

Alternatively, a 4.096 V external reference, such as the ADR434 or ADR444, can be connected to the unbuffered REF input of the ADC using a buffer amplifier such as the AD8031 as shown in Figure 1. This approach is common for multichannel applications where the system reference is shared by several ADCs.

The ADR434 and ADR444 configurations also excel for single channel applications where a low reference temperature coefficient (3 ppm/°C maximum for ADR434B and ADR444B) is required. The 7 V rail used to supply the ADA4897-1 op amps can also supply the V_{IN} supply pin of the ADR434 or ADR444.

Another attractive 4.096 V reference is the ADR4540 low dropout (>300 mV) high accuracy reference that allows operation on a 5 V supply.

The ADA4897-1 and AD8031 single op amps can be replaced with their dual versions (ADA4897-2 and AD8032, respectively) if desired.

For high input frequencies up to 3 MHz, the ADA4899-1 (15 mA/amp) is the recommended driving amplifier.

The ADA4938-1 (37 mA/amp) is excellent for signals up to 10 MHz and can also be used as a single-ended-to-differential converter.

The performance of this or any high speed circuit is highly dependent on proper printed circuit board (PCB) layout. This includes, but is not limited to, power supply bypassing, controlled impedance lines (where required), component placement, signal routing, and power and ground planes. (See MT-031 Tutorial, MT-101 Tutorial, and the article *A Practical Guide to High-Speed Printed-Circuit-Board Layout* for more detailed information regarding PCB layout.)

CIRCUIT EVALUATION AND TEST

The EVAL-AD7625EDZ evaluation board was developed to evaluate and test the AD7625 ADC. To test the circuit shown in Figure 1, the two ADA4899-1 op amps (U13, U14) were replaced with two ADA4897-1 op amps.

A detailed schematic and user instructions are available in the EVAL-AD7625EDZ documentation. This documentation describes how to run the ac tests described in this circuit note. Note that the +7 V and -2 V supplies for the input amplifiers are connected to the EVAL-AD7625EDZ board from the external dual power supply.

A functional block diagram of the test setup is shown in Figure 4, and a photograph of the evaluation board is shown in Figure 5.

Equipment Needed

The following equipment is required to test the circuit:

- The [EVAL-AD7625EDZ](#) modified evaluation board (includes software and 7 V dc wall wart power supply)
- The [EVAL-CED1Z](#) converter evaluation and demonstration platform board

- A low distortion signal generator, such as the Agilent 81150A or Audio Precision SYS2702
- A PC with a USB 2.0 port running Windows® XP, Windows Vista, or Windows 7 (32-Bit or 64-bit)
- A 7 V dc wall wart (included with evaluation board)
- External +7 V and -2 V dc supplies at 50 mA.

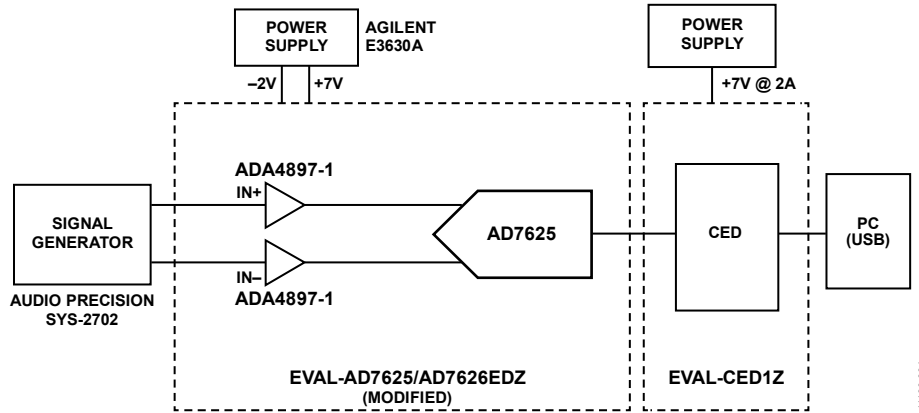

Figure 4. Functional Diagram of Test Setup

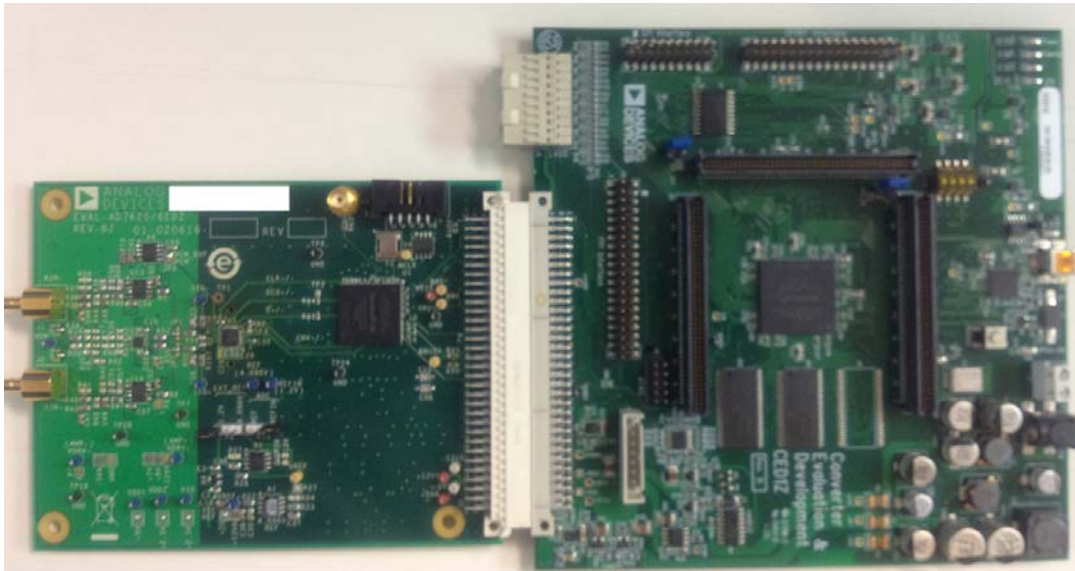

Figure 5. Modified [EVAL-AD7625EDZ](#) Board Connected to [EVAL-CED1Z](#) Board

LEARN MORE

CN-0307 Design Support Package:
<http://www.analog.com/CN0307-DesignSupport>

Ardizzoni, John, and Jonathan Pearson, *High Speed Differential ADC Driver Design Considerations*, Application Note AN-1026, Analog Devices, Inc.

Ardizzoni, John. "A Practical Guide to High-Speed Printed-Circuit-Board Layout," *Analog Dialogue* 39-09, September 2005.

AN-742 Application Note, *Frequency Domain Response of Switched Capacitor ADCs*. Analog Devices.

AN-827 Application Note, *A Resonant Approach to Interfacing Amplifiers to Switched-Capacitor ADCs*. Analog Devices.

Kester, Walt. 2006. *High Speed System Applications*. Analog Devices. Chapter 2, "Optimizing Data Converter Interfaces."

MT-031 Tutorial, *Grounding Data Converters and Solving the Mystery of "AGND" and "DGND."* Analog Devices.

MT-073 Tutorial, *High Speed Variable Gain Amplifiers*. Analog Devices.

MT-074 Tutorial, *Differential Drivers for Precision ADCs*, Analog Devices.

MT-075 Tutorial, *Differential Drivers for High Speed ADCs Overview*, Analog Devices.

MT-076 Tutorial, *Differential Driver Analysis*, Analog Devices.

MT-101 Tutorial, *Decoupling Techniques*. Analog Devices.

Analog Devices DiffAmpCalculator™ Design Tool

Data Sheets and Evaluation Boards

AD7625 Data Sheet

AD7625 Evaluation Board, EVAL-AD7625EDZ

ADA4897-1 Data Sheet

ADA4897-2 Data Sheet

AD8031 Data Sheet

AD8032 Data Sheet

ADR434 Datasheet

REVISION HISTORY**9/2018—Rev. 0 to Rev. A**

Changes to Figure 1 1

Changes to Circuit Description Section..... 2

11/2012—Revision 0: Initial Version

(Continued from first page) Circuits from the Lab circuits are intended only for use with Analog Devices products and are the intellectual property of Analog Devices or its licensors. While you may use the Circuits from the Lab circuits in the design of your product, no other license is granted by implication or otherwise under any patents or other intellectual property by application or use of the Circuits from the Lab circuits. Information furnished by Analog Devices is believed to be accurate and reliable. However, Circuits from the Lab circuits are supplied "as is" and without warranties of any kind, express, implied, or statutory including, but not limited to, any implied warranty of merchantability, noninfringement or fitness for a particular purpose and no responsibility is assumed by Analog Devices for their use, nor for any infringements of patents or other rights of third parties that may result from their use. Analog Devices reserves the right to change any Circuits from the Lab circuits at any time without notice but is under no obligation to do so.