

FEATURES

- Measures up to 8 battery cells in series
- Maximum lifetime total measurement error: 1.5 mV
- Stackable architecture for high voltage battery packs
- Built-in isoSPI interface
 - 2 Mb isolated serial communications
 - Uses a single twisted pair, up to 20 meters
 - Low EMI susceptibility and emissions
 - Bidirectional for broken wire protection
 - Capacitor or transformer coupled
- Hot plug tolerant without external protection
- ADBMS6817WFS models are developed for use in ISO 26262 applications for Automotive Safety Integrity Level Capability D (ASIL D)
- Diagnostics for IC and application circuit failure modes
- 304 μ s to measure all cells in a system
- 16-bit ADC with programmable noise filter
- Passive cell balancing up to 300 mA per channel with programmable PWM
- 7 GPIO or analog inputs
 - Temperature or other sensor inputs
 - Configurable as an I²C or SPI master
- Sleep state supply current: 5.5 μ A
- 48-lead LQFP package with exposed pad
- AEC-Q100 qualified for automotive applications

APPLICATIONS

- Electric and hybrid electric vehicles
- Backup battery systems
- Grid energy storage
- Large portable power banks

GENERAL DESCRIPTION

The ADBMS6817 is a multicell battery stack monitor that measures up to 8 series connected battery cells with a lifetime total measurement error (TME) of less than 1.5 mV. The cell measurement range of 0 V to 5 V makes the ADBMS6817 suitable for most battery chemistries. All 8 cells can be measured in 304 μ s, and lower data acquisition rates can be selected for high noise reduction.

Multiple ADBMS6817 devices can be connected in series, permitting simultaneous cell monitoring of long, high voltage battery strings. Each ADBMS6817 has an isoSPI™ interface for high speed, RF immune, long distance communications. Multiple devices are connected in a daisy chain with one host

For more information on the ADBMS6817, visit the [ADBMS6817 product page](#)

Rev. SpC

[Document Feedback](#)

Information furnished by Analog Devices is believed to be accurate and reliable. However, no responsibility is assumed by Analog Devices for its use, nor for any infringements of patents or other rights of third parties that may result from its use. Specifications subject to change without notice. No license is granted by implication or otherwise under any patent or patent rights of Analog Devices. Trademarks and registered trademarks are the property of their respective owners.

TYPICAL APPLICATION CIRCUIT

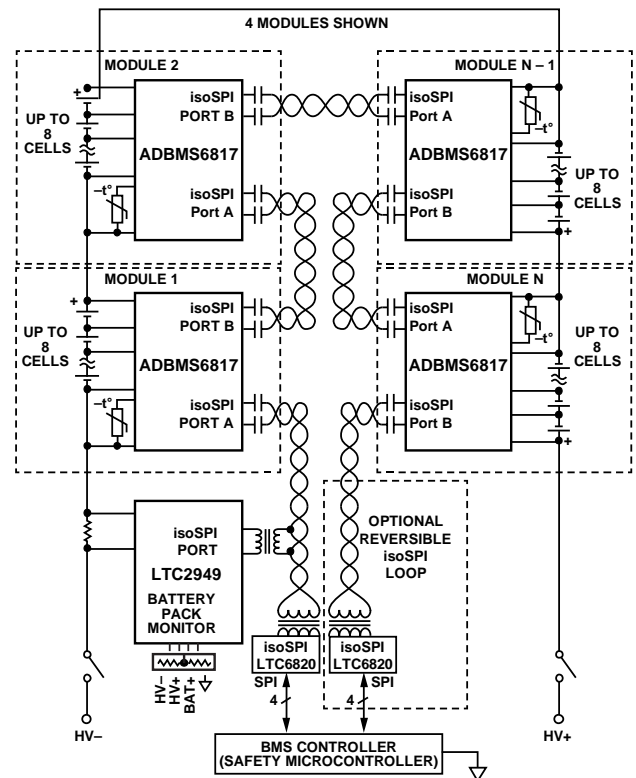

Figure 1.

processor connection for all devices. This daisy chain can be operated bidirectionally, ensuring communication integrity even in the event of a fault along the communication path.

The ADBMS6817 can be powered directly from the battery stack or from an isolated supply. The ADBMS6817 includes passive balancing for each cell, with individual pulse-width modulation (PWM) duty cycle control for each cell. Other features include an on-board 5 V regulator, seven general-purpose input/output (GPIO) lines, and a sleep state, where current consumption is reduced to 5.5 μ A.

The ADBMS6817WFS models are developed for use in ISO 26262 applications for Automotive Safety Integrity Level Capability D (ASIL D).

NOTES

I²C refers to a communications protocol originally developed by Philips Semiconductors (now NXP Semiconductors).