

18-Channel Multicell Battery Monitor

FEATURES

- ▶ Measures up to 18 battery cells in series
- ▶ Maximum lifetime TME: ± 1.8 mV at 3.3 V per cell (-40°C to $+125^{\circ}\text{C}$)
- ▶ Simultaneous and continuous measurement of cell voltages
- ▶ Configurable integrated low-pass filtering
- ▶ Stackable architecture for high voltage battery packs
- ▶ Built-in isoSPI interface
 - ▶ 2 Mbps isolated serial communications
 - ▶ Uses a single twisted pair, up to 20 meters per segment
 - ▶ Low EMI susceptibility and emissions
 - ▶ Bidirectional for broken wire protection
 - ▶ Capacitor or transformer coupled
- ▶ Hot plug tolerant without external protection
- ▶ Passive cell balancing up to 300 mA per channel
- ▶ 10 general-purpose analog inputs or digital I/O
 - ▶ Temperature or other sensor inputs
 - ▶ Configurable as an I²C or SPI master
- ▶ 2 additional analog inputs
- ▶ LPCM for cell and temperature monitoring in key-off state
- ▶ 4 μA sleep mode supply current
- ▶ Provisions for bus bars between channel 9 and 10
- ▶ AEC-Q100 qualified for automotive applications

APPLICATIONS

- ▶ Electric and hybrid electric vehicles
- ▶ Backup battery systems
- ▶ Grid energy storage

GENERAL DESCRIPTION

The ADBMS6832 is a multicell battery stack monitor that measures up to 18 series connected battery cells with a lifetime total measurement error (TME) of less than 2 mV over the full temperature range. The measurement input range of -2.5 V to $+5.5$ V makes the ADBMS6832 suitable for most battery chemistries and allows measurement of voltages across bus bars. A bus bar may also be placed between channel 9 and 10 with no measurement impact, and without dedicating any measurement channels.

All cells can be measured simultaneously and redundantly with two individual analog-to-digital converters (ADCs). The continuously operating ADCs with a high sampling rate of 4.096 MHz allow reduced external analog filtering and aliasing free measurement results. Higher noise reduction can be achieved by subsequent programmable infinite impulse response (IIR) filters.

Multiple ADBMS6832s can be connected in series, permitting simultaneous cell monitoring of long, high voltage battery strings. Each ADBMS6832 has an isolated serial port interface (isoSPI™) for high speed, RF immune, long distance communications. Multiple devices are connected in a daisy chain with one host processor connection. This daisy chain can be operated bidirectionally, ensuring communication integrity even in the event of a fault along the communication path.

The ADBMS6832 can be powered from the battery stack or an isolated supply. The ADBMS6832 includes passive balancing with individual pulse-width modulation (PWM) duty cycle control and up to 300 mA discharge current for each cell. Other features include an on-board 5 V regulator, 10 general-purpose inputs/outputs, and a sleep mode, where current consumption is reduced to 4 μA .

For more information on the ADBMS6832, see the [ADBMS6832 product page](#).

TYPICAL APPLICATION CIRCUIT

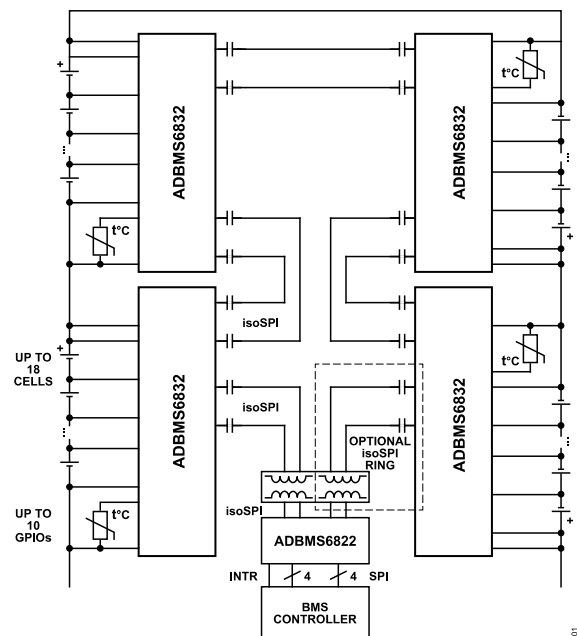

Figure 1.

NOTES