

FEATURES

**P1dB: 19 dBm typical at 2 GHz to 14 GHz
 at 2 GHz to 14 GHz**
Gain: 15.5 dB typical at 14 GHz to 22 GHz
Noise figure: 2.2 dB at 2 GHz to 14 GHz
Output IP3: 24 dBm typical at 2 GHz to 14 GHz
Power supply voltage: 5 V with a 55 mA total supply current
50 Ω matched input and output

APPLICATIONS

Test instrumentation
Microwave radios and very small aperture terminals (VSATs)
Military and space

GENERAL DESCRIPTION

The ADL9006CHIPS is a gallium arsenide (GaAs), pseudomorphic high electron mobility transistor (pHEMT), monolithic microwave integrated circuit (MMIC), low noise amplifier that operates from 2 GHz to 28 GHz. The amplifier provides 15.5 dB of gain, 2.2 dB of noise figure, 24 dBm of output third-order intercept (IP3), 20 dBm of output saturated power (P_{SAT}), and 19 dB of power output for 1 dB compression (P1dB) while requiring a 55 mA power supply current (I_{DD}) from a 5 V total supply voltage. The ADL9006CHIPS is self biased with only a single positive supply needed to achieve an I_{DD} of 55 mA. The ADL9006CHIPS amplifier input and output are internally matched to 50 Ω facilitating integration into multichip modules (MCMs).

FUNCTIONAL BLOCK DIAGRAM

Figure 1.

20122-001

TABLE OF CONTENTS

Features	1	Pin Configuration and Function Descriptions	6
Applications	1	Interface Schematics	6
General Description	1	Typical Performance Characteristics	7
Functional Block Diagram	1	Small Signal Response	7
Revision History	2	Large Signal Response	10
Specifications	3	Theory of Operation	13
2 GHz to 14 GHz	3	Applications Information	14
14 GHz to 22 GHz	3	Typical Application Circuit	14
22 GHz to 28 GHz	4	Mounting and Bonding Techniques for Millimeterwave GaAs MMICs	14
DC Specifications	4	Assembly Diagram	15
Absolute Maximum Ratings	5	Outline Dimensions	16
Thermal Resistance	5	Ordering Guide	16
Electronic Discharge (ESD) Ratings	5		
ESD Caution	5		

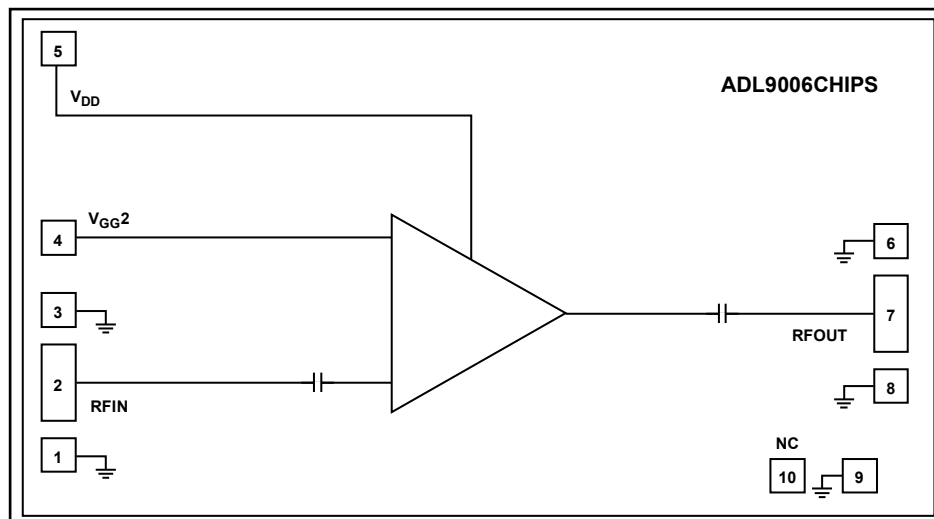
REVISION HISTORY

1/2021—Revision 0: Initial Version

SPECIFICATIONS

2 GHz TO 14 GHz

$V_{DD} = 5\text{ V}$, $I_{DD} = 55\text{ mA}$, $V_{GG2} = \text{open}$, and $T_A = 25^\circ\text{C}$, unless otherwise noted.

Table 1.

Parameter	Symbol	Test Conditions/Comments	Min	Typ	Max	Unit
FREQUENCY RANGE			2		14	GHz
GAIN	S21		13	15		dB
Gain Variation over Temperature				0.008		dB/°C
RETURN LOSS						
Input	S11			15		dB
Output	S22			18		dB
OUTPUT						
Power for 1 dB Compression	P1dB			19		dBm
Saturated Power	P_{SAT}		18	20		dBm
Third-Order Intercept	IP3	Measurement taken at output power (P_{OUT}) per tone = 0 dBm		24		dBm
Second-Order Intercept	IP2	Measurement taken at P_{OUT} per tone = 0 dBm		24		dBm
NOISE FIGURE				2.2		dB

14 GHz TO 22 GHz

$V_{DD} = 5\text{ V}$, $I_{DD} = 55\text{ mA}$, $V_{GG2} = \text{open}$, and $T_A = 25^\circ\text{C}$, unless otherwise noted.

Table 2.

Parameter	Symbol	Test Conditions/Comments	Min	Typ	Max	Unit
FREQUENCY RANGE			14		22	GHz
GAIN	S21		13.5	15.5		dB
Gain Variation over Temperature				0.013		dB/°C
RETURN LOSS						
Input	S11			20		dB
Output	S22			25		dB
OUTPUT						
Power for 1 dB Compression	P1dB			17		dBm
Saturated Power	P_{SAT}		15.5	18		dBm
Third-Order Intercept	IP3	Measurement taken at P_{OUT} per tone = 0 dBm		21		dBm
Second-Order Intercept	IP2	Measurement taken at P_{OUT} per tone = 0 dBm		30		dBm
NOISE FIGURE				2.5		dB

22 GHz TO 28 GHz

$V_{DD} = 5\text{ V}$, $I_{DD} = 55\text{ mA}$, $V_{GG2} = \text{open}$, and $T_A = 25^\circ\text{C}$, unless otherwise noted.

Table 3.

Parameter	Symbol	Test Conditions/Comments	Min	Typ	Max	Unit
FREQUENCY RANGE			22		28	GHz
GAIN	S21		12.5	15		dB
Gain Variation over Temperature				0.018		dB/°C
RETURN LOSS						
Input	S11			18		dB
Output	S22			20		dB
OUTPUT						
Saturated Power	P_{SAT}		15	17		dBm
Third-Order Intercept	IP3	Measurement taken at P_{OUT} per tone = 0 dBm		16.5		dBm
Second-Order Intercept	IP2	Measurement taken at P_{OUT} per tone = 0 dBm		36		dBm
NOISE FIGURE				4		dB

DC SPECIFICATIONS**Table 4.**

Parameter	Symbol	Test Conditions/Comments	Min	Typ	Max	Unit
TOTAL SUPPLY CURRENT	I_{DD}	$V_{DD} = 5\text{ V}$		55		mA
POWER SUPPLY VOLTAGE	V_{DD}		4	5	7	V
V_{GG2}	V_{GG2}	$V_{GG2} = \text{open}$ (nominal condition)	-2.0		+2.6	V

ABSOLUTE MAXIMUM RATINGS

Table 5.

Parameter	Rating
Drain Bias Voltage	8 V
Gate Control (V_{GG2})	-2.6 V to +3.6 V
RFIN	20 dBm
Continuous Power Dissipation (P_{DISS}) at $T_{DIE\ BOTTOM} = 85^{\circ}C$ (Derate 22.1 mW/ $^{\circ}C$ above 85 $^{\circ}C$)	1.72 W
Temperature	
Storage Range	-65 $^{\circ}C$ to +150 $^{\circ}C$
Operating Range (Die Bottom)	-55 $^{\circ}C$ to +85 $^{\circ}C$
Channel to Maintain 1,000,000 Hour Meant Time to Failure (MTTF)	175
Nominal Channel ($T_A = 85^{\circ}C$, $V_{DD} = 5$ V)	97.43

Stresses at or above those listed under Absolute Maximum Ratings may cause permanent damage to the product. This is a stress rating only; functional operation of the product at these or any other conditions above those indicated in the operational section of this specification is not implied. Operation beyond the maximum operating conditions for extended periods may affect product reliability.

THERMAL RESISTANCE

Thermal performance is directly linked to system design and operating environment. Careful attention to printed circuit board (PCB) thermal design is required.

θ_{JC} is the channel to case, thermal resistance, channel to bottom of the die using die attach epoxy.

Table 6. Thermal Resistance

Package	θ_{JC}^1	Unit
C-10-8	45.2	$^{\circ}C/W$

¹ θ_{JC} was determined by simulation under the following conditions: the heat transfer is due solely to the thermal conduction from the channel, to the die bottom, and the die bottom is held constant at the operating temperature of 85 $^{\circ}C$.

ELECTRONIC DISCHARGE (ESD) RATINGS

The following ESD information is provided for handling of ESD-sensitive devices in an ESD protected area only.

Human body model (HBM) per ANSI/ESD A/JEDEC JS-001.

ESD Ratings for ADL9006CHIPS

Table 7. ADL9006CHIPS, 10-Pad Bare Die (CHIP)

ESD Model	Withstand Threshold (V)	Class
HBM	500	1B

ESD CAUTION



ESD (electrostatic discharge) sensitive device. Charged devices and circuit boards can discharge without detection. Although this product features patented or proprietary protection circuitry, damage may occur on devices subjected to high energy ESD. Therefore, proper ESD precautions should be taken to avoid performance degradation or loss of functionality.

PIN CONFIGURATION AND FUNCTION DESCRIPTIONS

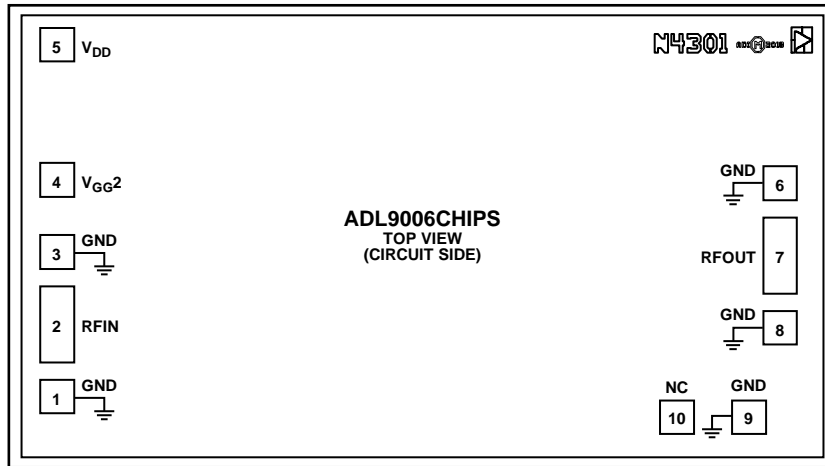

NOTES
1. NC = NO CONNECT. SEE THE ASSEMBLY DIAGRAM, FIGURE 42, FOR PROPER BONDING.

Figure 2. Pad Configuration

20122-002

Table 8. Pad Function Descriptions

Pad No.	Mnemonic	Description
1, 3, 6, 8, 9	GND	Ground. The GND pads are connected to the die bottom using thru die vias. See the assembly diagram for proper bonding (see Figure 42). See Figure 5 for the interface schematic.
2	RFIN	RF Input. RFIN is ac-coupled and matched to 50 Ω. See Figure 3 for the interface schematic.
4	V _{GG2}	Gain Control. V _{GG2} is dc-coupled and accomplishes gain control by reducing the internal voltage and by becoming more negative. Attach bypass capacitors to V _{GG2} as shown in the assembly diagram (see Figure 42). Under normal operating conditions, V _{GG2} is left open. See Figure 4 for the interface schematic.
5	V _{DD}	Power Supply Voltage for the Amplifier. Connect a dc bias to provide quiescent drain current (I _{bQ}). See Figure 6 for the interface schematic.
7	RFOUT	RF Output. RFOUT is ac-coupled and matched to 50 Ω. See Figure 7 for the interface schematic.
10	NC	No Connect. See the assembly diagram, Figure 42, for proper bonding.
Die Bottom	GND	Die bottom must be connected to RF and dc ground. See Figure 5 for the interface schematic.

INTERFACE SCHEMATICS

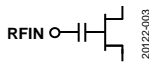

Figure 3. RFIN Interface Schematic

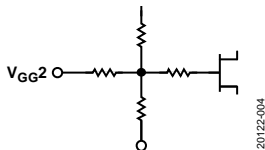

Figure 4. V_{GG2} Interface Schematic



Figure 5. GND Interface Schematic

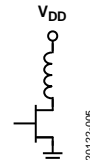

Figure 6. V_{DD} Interface Schematic

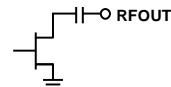

Figure 7. RFOUT Interface Schematic

TYPICAL PERFORMANCE CHARACTERISTICS

SMALL SIGNAL RESPONSE

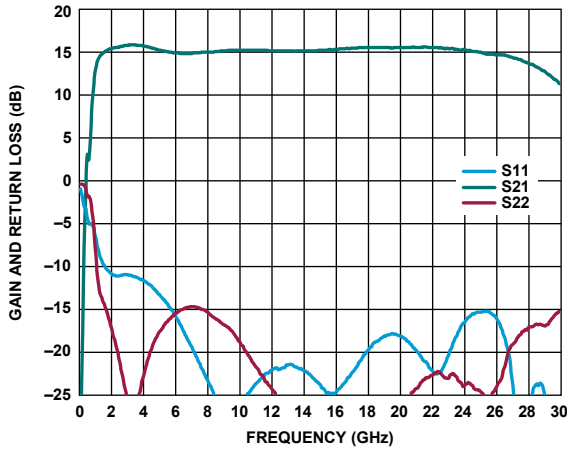

Figure 8. Gain and Return Loss vs. Frequency

20122-008

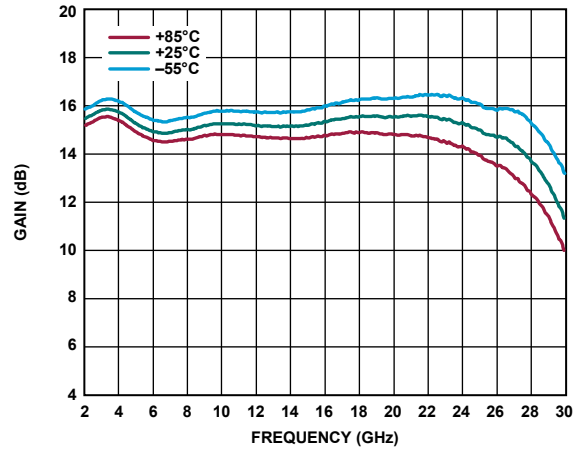

Figure 11. Gain vs. Frequency at Various Temperatures

20122-011

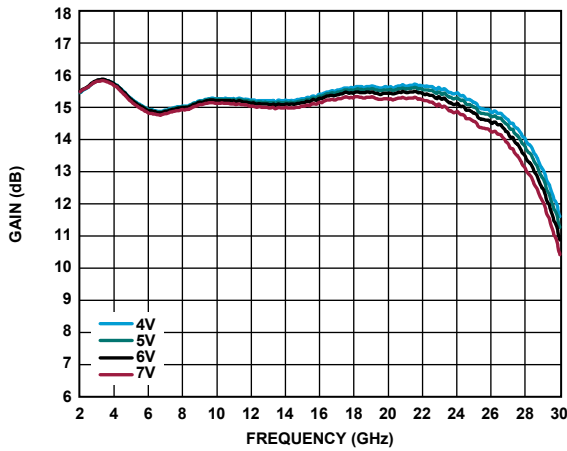

Figure 9. Gain vs. Frequency at Various Supply Voltages

20122-009

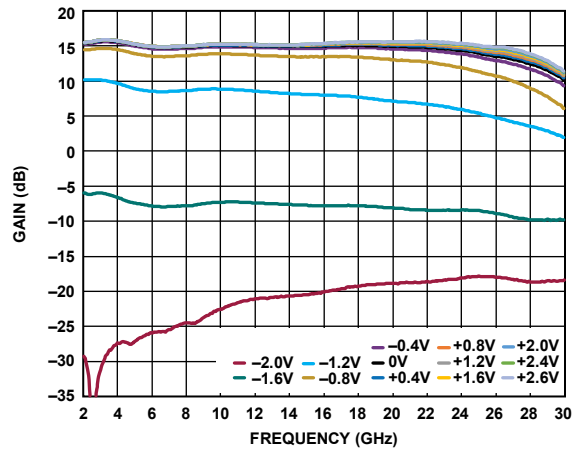

Figure 12. Gain vs. Frequency at Various V_{GG2} Voltages

20122-012

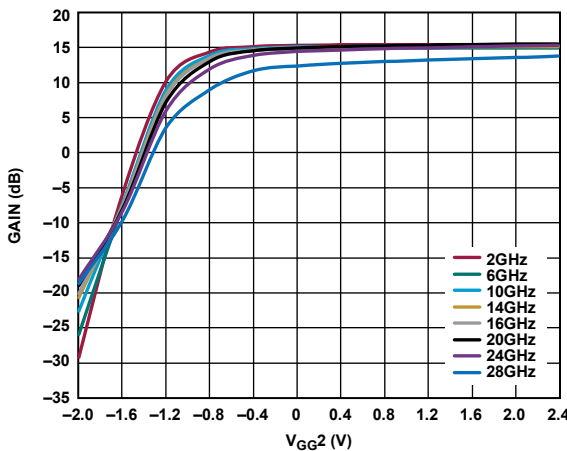

Figure 10. Gain vs. V_{GG2} for Various Frequencies

20122-010

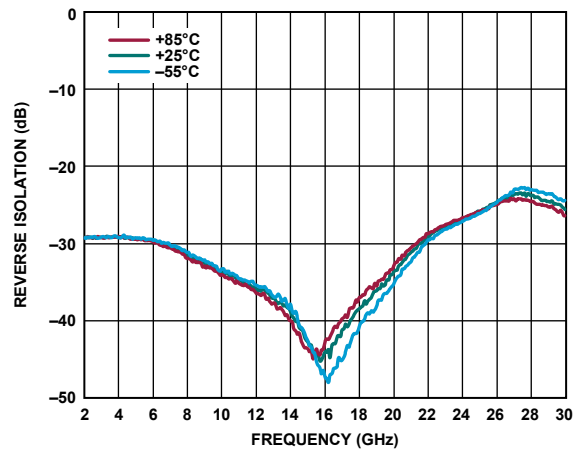

Figure 13. Reverse Isolation vs. Frequency at Various Temperatures

20122-013

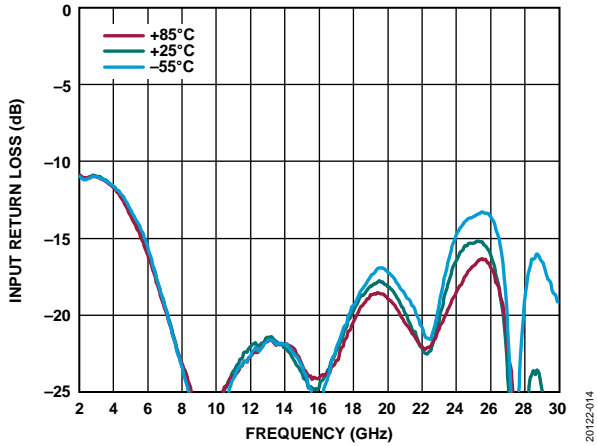

Figure 14. Input Return Loss vs. Frequency at Various Temperatures

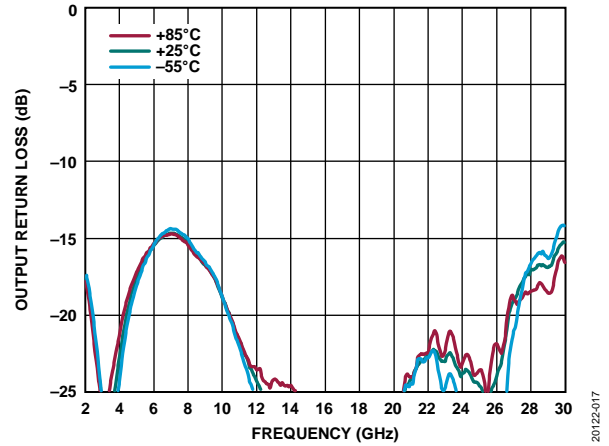

Figure 17. Output Return Loss vs. Frequency at Various Temperatures

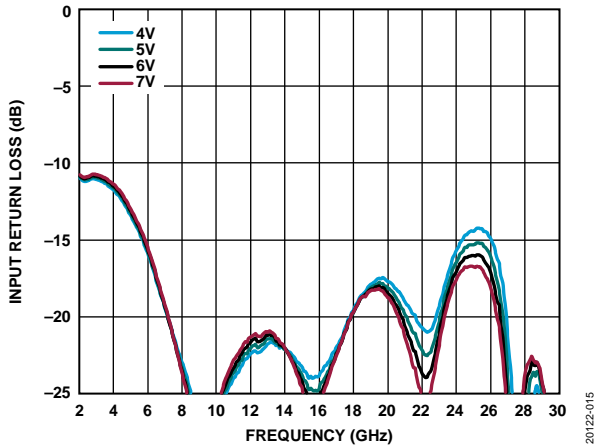

Figure 15. Input Return Loss vs. Frequency at Various Supply Voltages

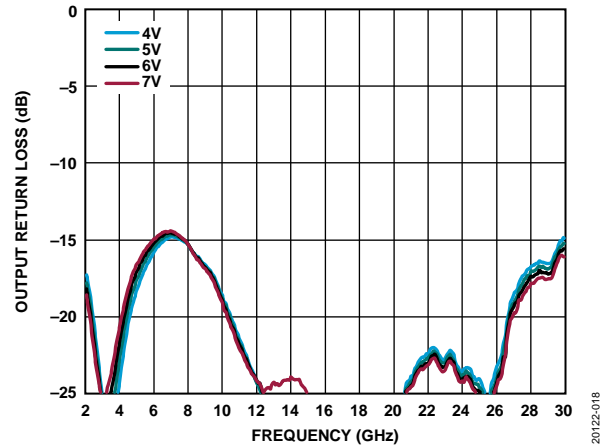

Figure 18. Output Return Loss vs. Frequency at Various Supply Voltages

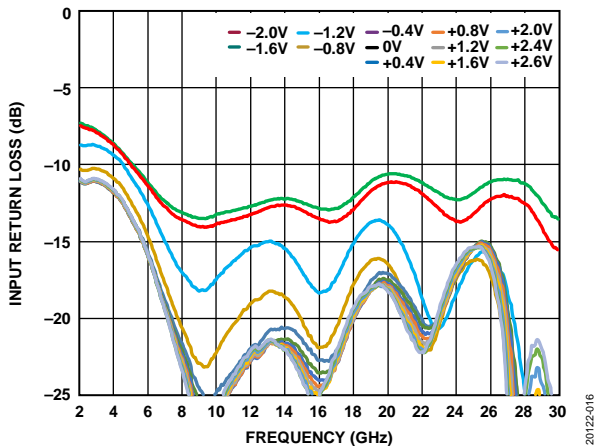

Figure 16. Input Return Loss vs. Frequency at Various V_{GG2} Voltages

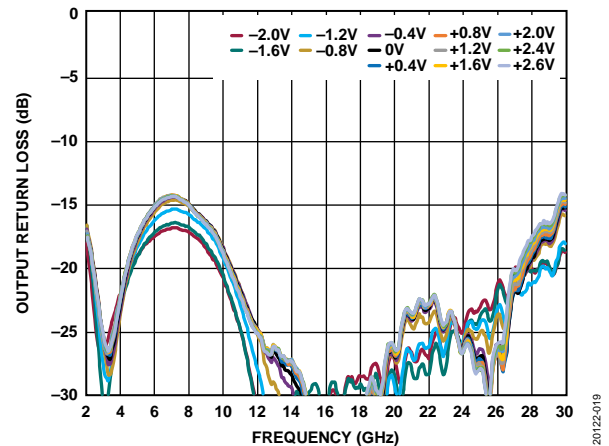

Figure 19. Output Return Loss vs. Frequency at Various V_{GG2} Voltages

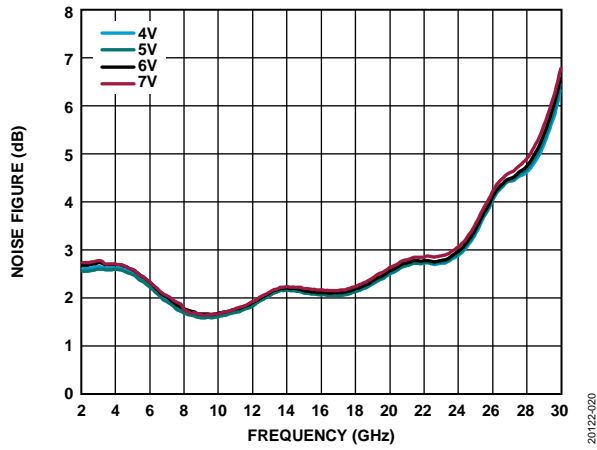

Figure 20. Noise Figure vs. Frequency at Various Supply Voltages

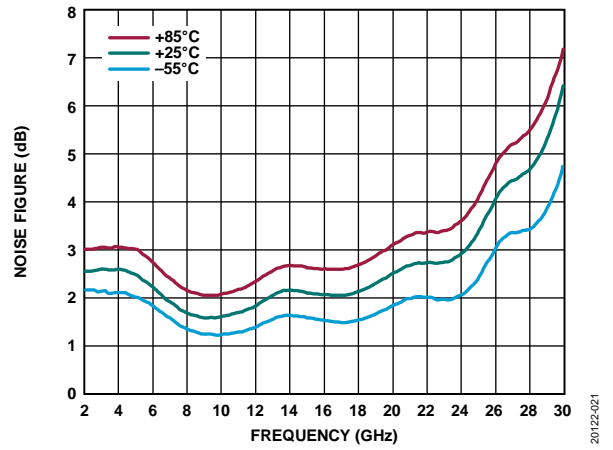

Figure 21. Noise Figure vs. Frequency at Various Temperatures

LARGE SIGNAL RESPONSE

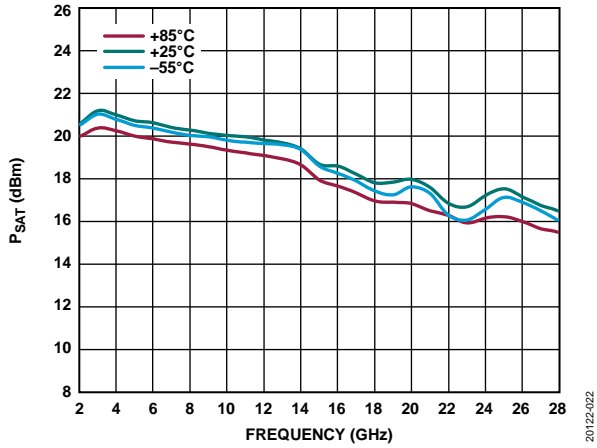

Figure 22. P_{SAT} vs. Frequency at Various Temperatures

20122-022

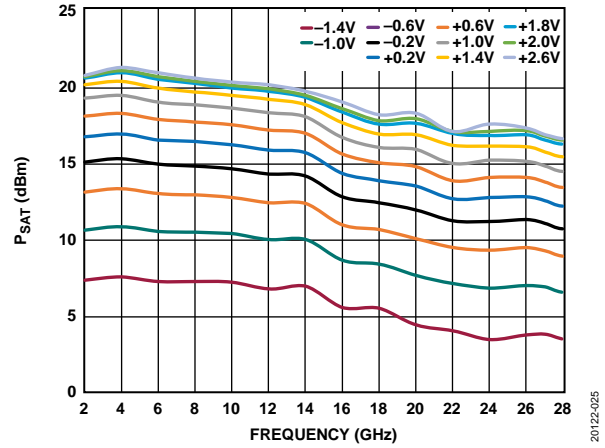

Figure 25. P_{SAT} vs. Frequency at Various V_{GG2} Voltages

20122-025

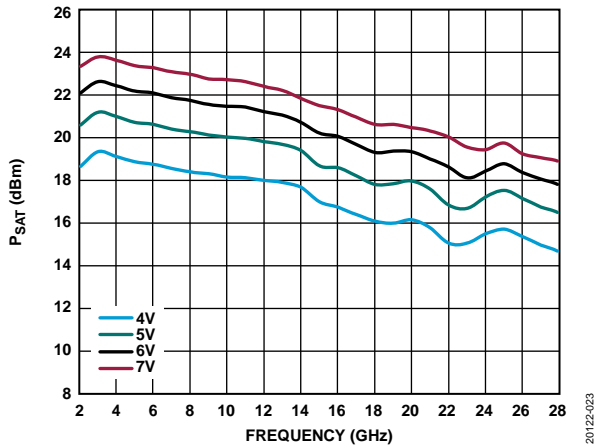

Figure 23. P_{SAT} vs. Frequency at Various Supply Voltages

20122-023

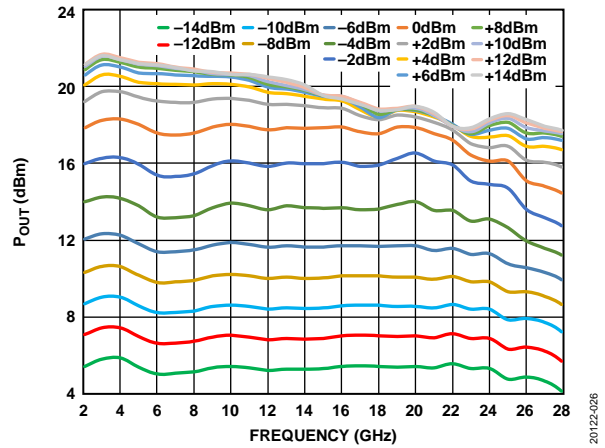

Figure 26. P_{OUT} vs. Frequency at Various Input Power Levels

20122-026

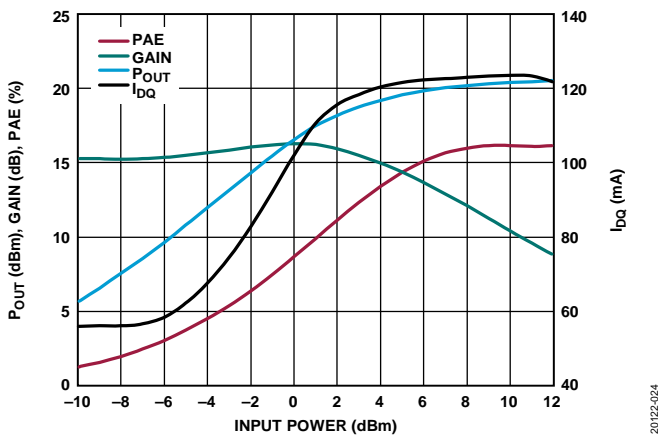

Figure 24. P_{OUT} , Gain, Power Added Efficiency (PAE), and I_{DQ} vs. Input Power, 2 GHz, $V_{DD} = 5$ V

20122-024

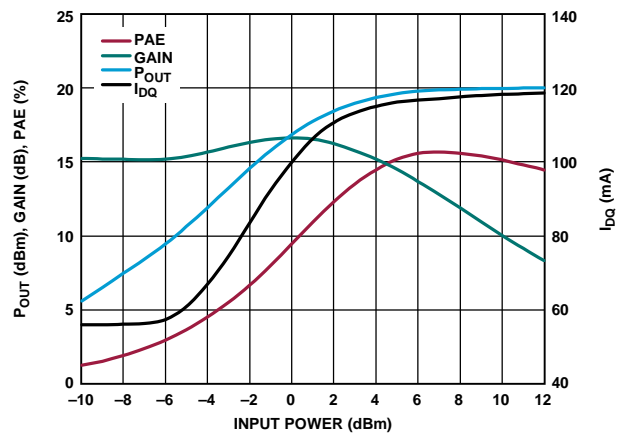

Figure 27. P_{OUT} , Gain, PAE, and I_{DQ} vs. Input Power, 10 GHz, $V_{DD} = 5$ V

20122-027

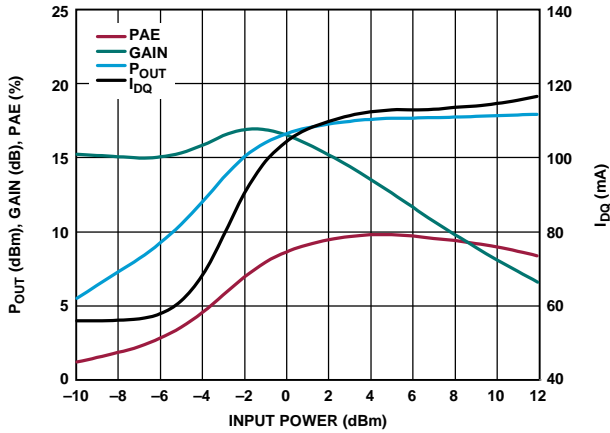

Figure 28. P_{OUT} , Gain, PAE, and I_{DQ} vs. Input Power, 20 GHz, $V_{DD} = 5 V$

20122-028

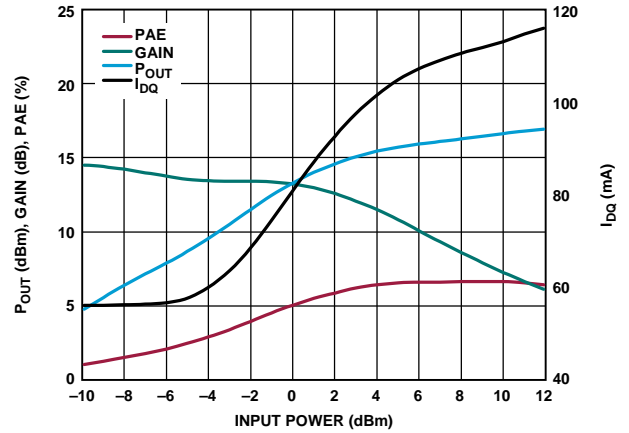

Figure 31. P_{OUT} , Gain, PAE, and I_{DQ} vs. Input Power, 26 GHz, $V_{DD} = 5 V$

20122-031

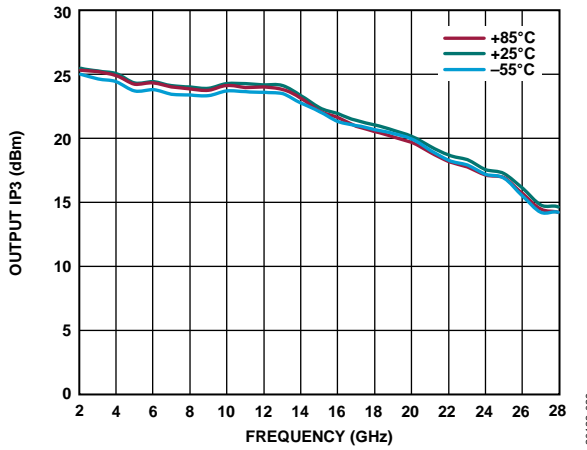

Figure 29. Output IP3 vs. Frequency for Various Temperatures at $P_{OUT} = 0 \text{ dBm per Tone}$

20122-029

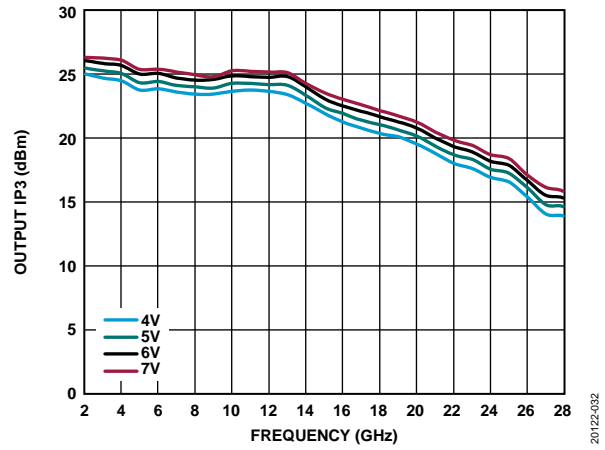

Figure 32. Output IP3 vs. Frequency at Various Supply Voltages at $P_{OUT} = 0 \text{ dBm per Tone}$

20122-032

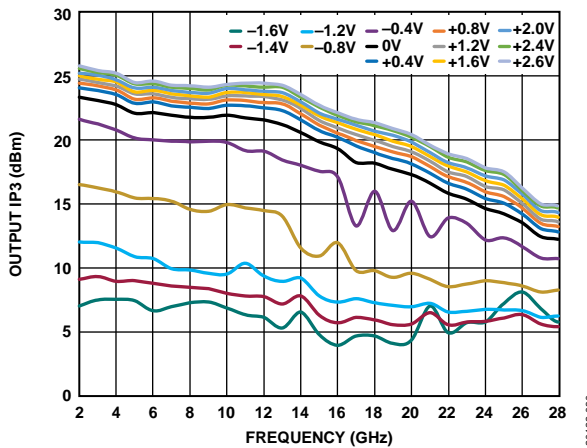

Figure 30. Output IP3 vs. Frequency at Various V_{GG2} Voltages

20122-030

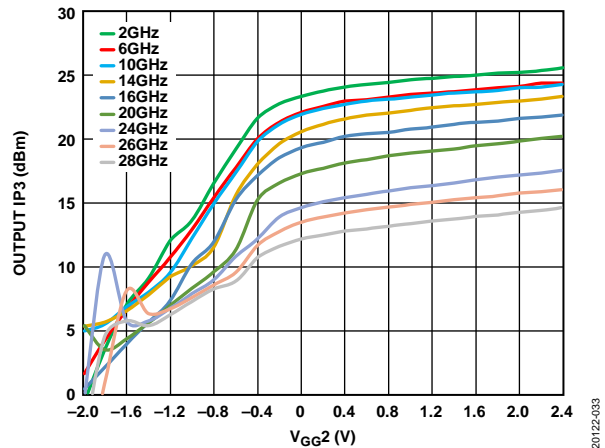

Figure 33. Output IP3 vs. V_{GG2} for Various Frequencies

20122-033

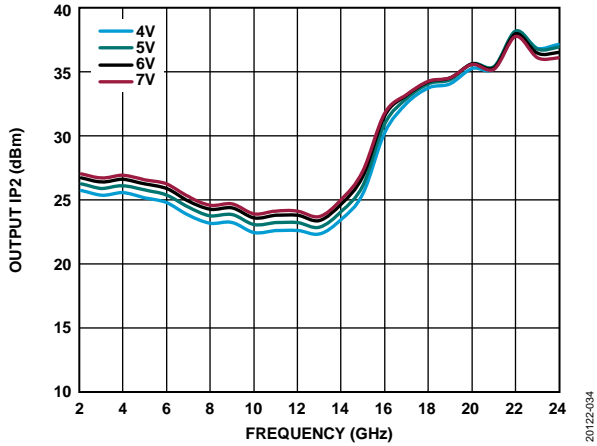

Figure 34. Output IP2 vs. Frequency at Various Supply Voltages at $P_{OUT} = 0$ dBm per Tone

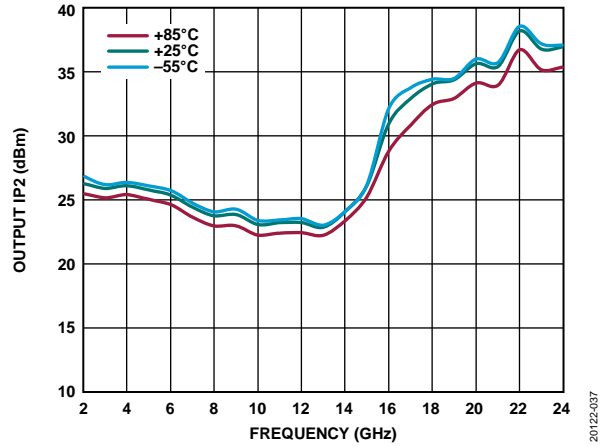

Figure 37. Output IP2 vs. Frequency for Various Temperatures at $P_{OUT} = 0$ dBm per Tone

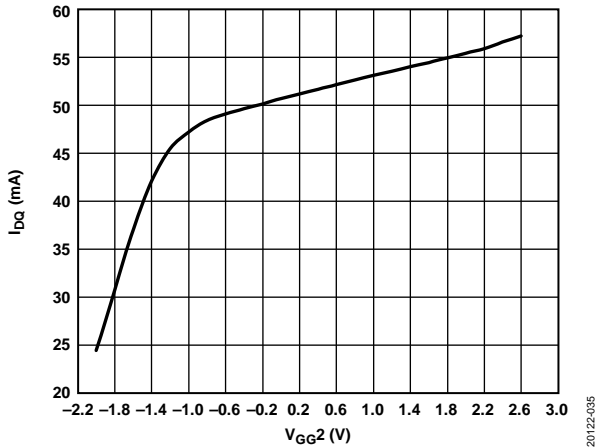

Figure 35. I_{DQ} vs. V_{GG2} Voltages, $V_{DD} = 5$ V

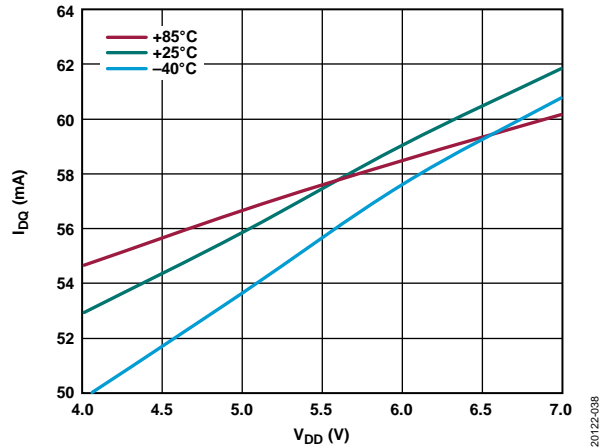

Figure 38. I_{DQ} vs. V_{DD} for Various Temperatures

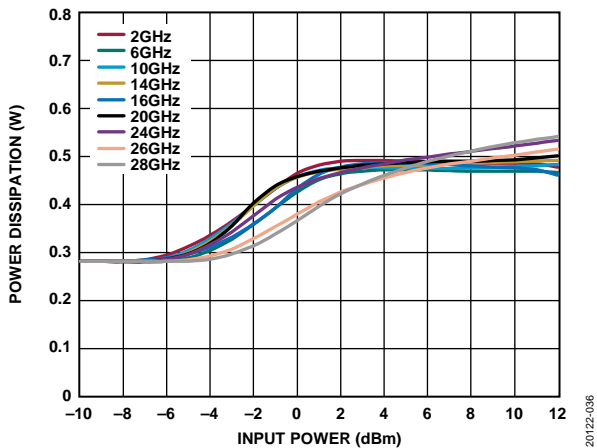

Figure 36. Power Dissipation vs. Input Power at Various Frequencies, $T_A = 85^\circ\text{C}$

20122-034

20122-037

20122-035

20122-038

20122-036

THEORY OF OPERATION

The ADL9006CHIPS is a GaAs, pHEMT, MMIC, low noise amplifier. The basic architecture of the ADL9006CHIPS is that of a single-supply, biased, cascode distributed amplifier with an integrated RF choke for the drain. A simplified schematic of this architecture is shown in Figure 39.

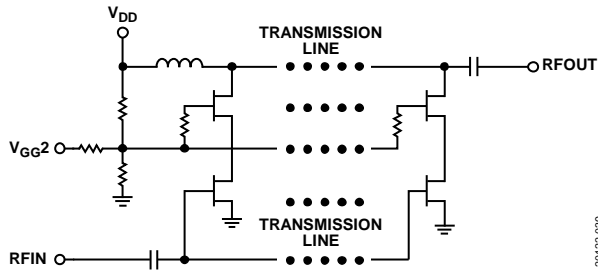

Figure 39. Architecture and Simplified Schematic

Though the gate bias voltages of the upper field effect transistors (FETs) are set internally by a resistive voltage divider tapped off of V_{DD} , the V_{GG2} pin is provided to allow the user an optional means of changing the gate bias of the upper FETs. Adjustment of the V_{GG2} pin voltage across the -2.0 V to $+2.6$ V range changes the gate bias of the upper FETs, thus affecting gain changes depending on the frequency.

APPLICATIONS INFORMATION

TYPICAL APPLICATION CIRCUIT

As shown in the typical application circuit, capacitive bypassing is required for V_{DD} (see Figure 40). Gain control is possible through the application of a dc voltage to V_{GG2} . If gain control is used, V_{GG2} must be bypassed by 100 pF, 0.01 μ F, and 4.7 μ F capacitors. If gain control is not used, V_{GG2} can be either left open or capacitively bypassed.

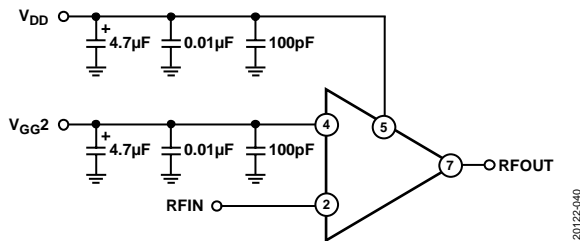

Figure 40. Typical Application Circuit

The recommended power-up bias sequence follows:

1. Set V_{DD} to 5 V (this results in an I_{DQ} near its specified typical value).
2. If the gain control function is used, apply a voltage within the -2.0 V to $+2.6$ V range to V_{GG2} until the desired gain is achieved.
3. Apply the RF input signal.

The recommended power-down bias sequence follows:

1. Turn off the RF input signal.
2. Remove the V_{GG2} voltage or set it to 0 V.
3. Set V_{DD} to 0 V.

Unless otherwise noted, all measurements and data shown were taken using the typical application circuit (see Figure 40) biased per the conditions listed in the Specifications section. The bias conditions detailed in the Specifications section are the operating points recommended to optimize the overall performance. Operation using other bias conditions may provide performance that differs from what is shown in this data sheet. To obtain the best performance while not damaging the device, follow the recommended biasing sequence outlined in this section.

MOUNTING AND BONDING TECHNIQUES FOR MILLIMETERWAVE GaAs MMICs

Attach the die directly to the ground plane with conductive epoxy. To bring the RF to and from the chip, use 50 Ω microstrip transmission lines on 0.127 mm (5 mil) thick alumina, thin film substrates (see Figure 41).

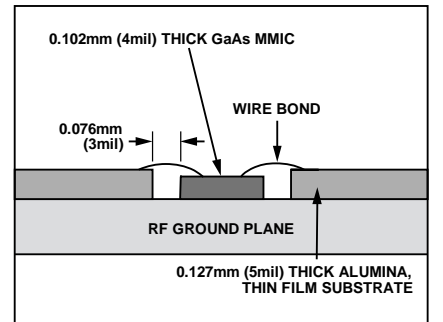

Figure 41. Routing RF Signals

To minimize bond wire length, place microstrip substrates as close to the die as possible. Typical die to substrate spacing is 0.076 mm to 0.152 mm (3 mil to 6 mil). All data is taken with the chip connected via two 0.025 mm (0.98 mil) wire bonds of minimal length, 0.31 mm (1.22 mil).

Handling Precautions

To avoid permanent damage, adhere to the following precautions:

- All bare die ship in either wafer or gel-based ESD protective containers, sealed in an ESD protective bag. After the sealed ESD protective bag is opened, store all die in a dry nitrogen environment.
- Handle the chips in a clean environment. Never use liquid cleaning systems to clean the chip.
- Follow ESD precautions to protect against ESD strikes.
- While bias is applied, suppress instrument and bias supply transients. To minimize inductive pickup, use shielded signal and bias cables.
- Handle the chip along the edges with a vacuum collet or with a sharp pair of bent tweezers. The surface of the chip may have fragile air bridges and must not be touched with vacuum collet, tweezers, or fingers.
- For mounting, the chip is back metallized and can be die mounted with electrically conductive epoxy. The mounting surface must be clean and flat.
- For the epoxy die attachment, the ABLETHERM 2600BT is recommended. Apply a minimum amount of epoxy to the mounting surface so that a thin epoxy fillet is observed around the perimeter of the chip after placing it into position. Cure the epoxy per the schedule provided by the manufacturer. For wire bonding, RF bonds made with 1 mil gold wire are recommended for the RF ports. These bonds must be thermosonically bonded with a force of 40 g to 60 g. DC bonds of 0.025 mm (1 mil) diameter, thermosonically bonded, are recommended. Create ball bonds with a force of 40 g to 50 g and wedge bonds with a force of 18 g to 22 g. Create all bonds with a nominal stage temperature of 150°C. Apply a minimum amount of ultrasonic energy to achieve reliable bonds, and keep all bonds as short as possible, less than 0.305 mm (12 mil).

ASSEMBLY DIAGRAM

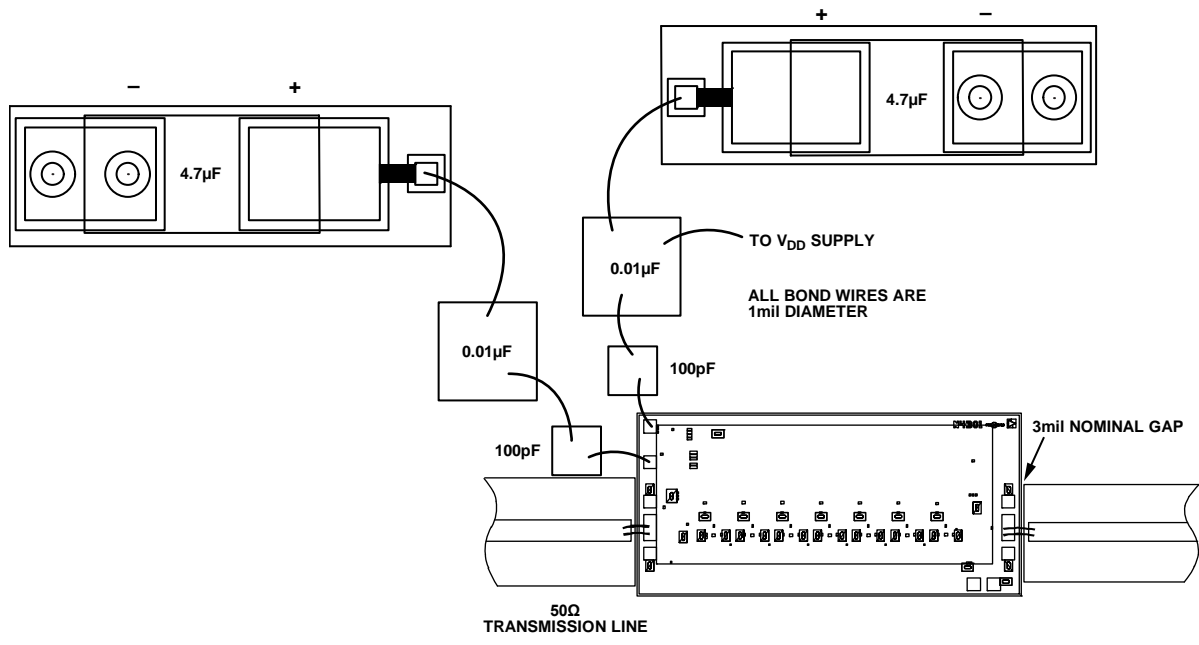
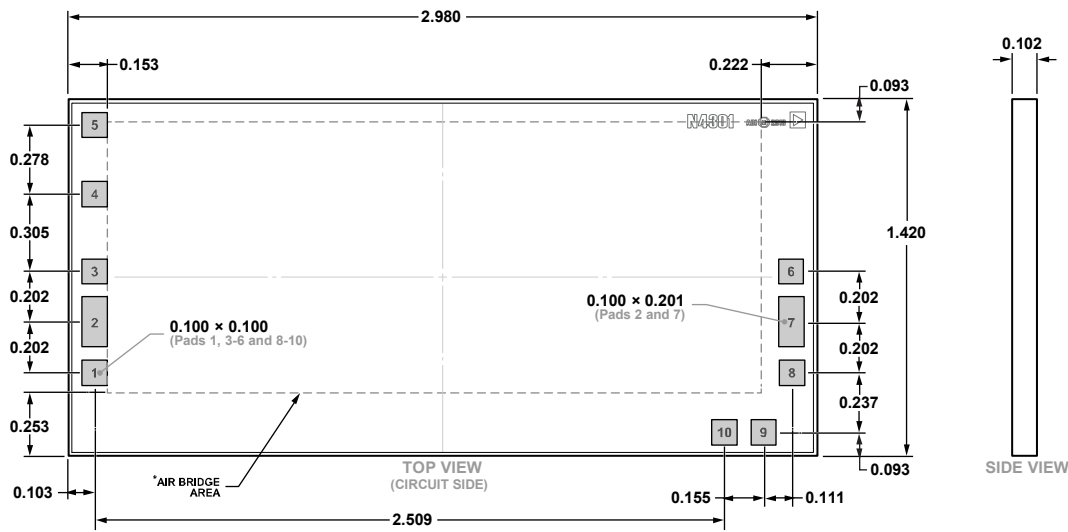

Figure 42. Assembly Diagram

20122-042

OUTLINE DIMENSIONS



*This die utilizes fragile air bridges. Any pickup tools used must not contact this area.

Figure 43. 10-Pad Bare Die [CHIP]
(C-10-8)

Dimensions shown in millimeter

08-26-2020-B

ORDERING GUIDE

Model ^{1,2}	Temperature Range	Package Description	Package Option
ADL9006CHIPS	-55°C to +85°C	10-Pad Bare Die [CHIP]	C-10-8
ADL9006C-KIT	-55°C to +85°C	10-Pad Bare Die [CHIP]	C-10-8

¹ The ADL9006CHIPS and ADL9006C-KIT are RoHS compliant parts.

² The ADL9006C-KIT is a sample order of two devices.