



Low Voltage DC-DC Switching Power Reference Design

Preliminary Technical Data

FCDC 00105b

FEATURES

A high density and cost-effective solution for low voltage DC-DC power conversion

Input Voltage Range: 10.8 V – 13.2 V

Output Voltage: 2.5 V

Output Current: 4 A

Single sided 1" x 1" PCB

Convenient access to many of the features of the ADP1828

LOW VOLTAGE DC-DC SWITCHING POWER REFERENCE DESIGN DESCRIPTION

The ADP1828 Demo Board uses the single channel voltage mode ADP1828 switching controller IC to offer a high density and cost effective solution for converting a 10.8 V to 13.2 V input voltage to 2.5 V capable of supplying 4 A of load current. The demo board is a single sided PCB that is 1" x 1". The converter switches at 600kHz nominally, which allows the design to use a small output inductor and small MLCC output capacitors and still perform well during a high slew rate load transient event (see Performance section).

The ADP1828 Demo Board has multiple pins easily accessible on the board.

- EN (input): Logic High enables the converter. Logic Low disables the converter. See ADP1828 datasheet for threshold and tolerances. Shipped configuration connects EN to Vin via a 0-ohm jumper. Remove Ren1 to use this feature.
- TRK (input): Drive this pin from a voltage divider from the master voltage. Shipped configuration bypasses this feature by connecting the TRK to the VREG node. Remove 0-ohm jumper (Rt3) to use this feature.
- PwrGd (output): Indicates when the output voltage is within regulation. See ADP1828 datasheet for tolerances.
- Sync (input): An external signal applied to this pin will cause the IC to switch at the corresponding frequency. Shipped configuration bypasses this feature by pulling the Sync pin low. Remove this 0-ohm jumper (Rsync) to use this feature.
- CKOut (output): To synchronize another switching controller (ADP1829 or another ADP1828) to the internal clock frequency of the ADP1828 connect the Sync pin of the other IC to this pin on the demo board.

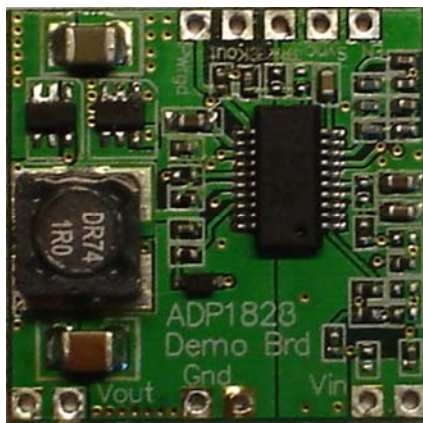

Figure 1. ADP1828 Demo Board

Rev. A

Reference designs are as supplied "as is" and without warranties of any kind, express, implied, or statutory including, but not limited to, any implied warranty of merchantability or fitness for a particular purpose. No license is granted by implication or otherwise under any patents or other intellectual property by application or use of reference designs. Information furnished by Analog Devices is believed to be accurate and reliable. However, no responsibility is assumed by Analog Devices for its use, nor for any infringements of patents or other rights of third parties that may result from its use. Analog Devices reserves the right to change devices or specifications at any time without notice. Trademarks and registered trademarks are the property of their respective owners. Reference designs are not authorized to be used in life support devices or systems.

TABLE OF COTENTS

Features..... 1

Low Voltage DC-DC Switching Power Reference Design Description..... 1

Revision History..... 3

ADP1828 General Description 4

Powering the ADP1828 Demo Board 4

 Input Power Source 4

 Output Load 4

 Input and Output Voltmeters 4

 Turning On the Evaluation Board 5

Schematic 5

Bill of Materials 6

Performance..... 7

PCB Layout Files 15

Notes:..... 21

TABLE OF FIGURES

Figure 1. ADP1828 Demo Board 1

Figure 2. Schematic 5

Figure 3. Efficiency..... 7

Figure 4. Load Regulation 7

Figure 5. Switching regulator turn on at no load: Ch1 = 2.5 V, Ch2 = Vin 8

Figure 6. Switching regulator turn on at full load: Ch1 = 2.5 V, Ch2 = Vin 8

Figure 7. Switching regulator turn off at no load: Ch1 = 3.5 V, Ch2 = Vin 9

Figure 8. Switching regulator turn off at full load: Ch1 = 2.5 V, Ch2 = Vin 9

Figure 9. Vin and Vout Ripple. Load current = 0A. Vin = 13.2V 10

Figure 10. Vin and Vout Ripple. Load Current = 4A. Vin =13.2V 10

Figure 11. Vin and Vout Ripple. Load Current=0A Vin=10.8V 11

Figure 12. Vin and Vout Ripple. Load Current = 4A. Vin = 10.8V 11

Figure 13. Transient. 2A Load Step (2A -> 4A). 2A Load Release (4A ->2A). Vin=10.8) (infinite persistence)..... 12

Figure 14. 2A Load Step (2A->4A). Vin=13.2V (infinite persistence) 12

Figure 15. 2A Load Release (4A-> 2A). Vin = 13.2V (infinite persistence)..... 13

Figure 16. Load Transient. 2A Load Step (2A -> 4A). 2A Load Release (4A ->2A). Vin=10.8V 13

Figure 17. (infinite persistence) 13

Figure 18. 2A Load Step (2A ->4A). Vin=10.8V (infinite persistence) 14

Figure 19. 2A Load Release (4A -> 2A). Vin=10.8V (infinite persistence)..... 14

Figure 20. Top PCB Layer 15

Figure 21. Second PCB Layer 16

Figure 22. Third PCB Layer 17

Figure 23. Fourth PCB Layer 18
Figure 24. Fifth PCB Layer..... 19
Figure 25. Sixth and Bottom PCB Layer 20

REVISION HISTORY

2/28/2008—Revision 0: Initial Version

ADP1828 GENERAL DESCRIPTION

The ADP1828 is a versatile and synchronous PWM voltage mode buck controller. It drives an all N-channel power stage to regulate an output voltage as low as 0.6 V to 85% of the input voltage and is sized to handle large MOSFETs for point-of-load regulators. The ADP1828 is ideal for a wide range of high power applications, such as DSP and processor core I/O power, and general-purpose power in telecommunications, medical imaging, PC, gaming, and industrial applications. It operates from input bias voltages of 3 V to 18 V with an internal LDO that generates a 5 V output for input bias voltages greater than 5.5 V. The ADP1828 operates at a pin-selectable, fixed switching frequency of either 300 kHz or 600 kHz, or at any frequency between 300 kHz and 600 kHz with a resistor. The switching frequency can also be synchronized to an external clock up to 2× the part's nominal oscillator frequency. The clock output can be used for synchronizing additional ADP1828s (or the ADP1829 controllers), thus eliminating the need for an external clock source. The ADP1828 includes soft start protection to limit any inrush current from the input supply during startup, reverse current protection during soft start for a precharged output, as well as a unique adjustable lossless current-limit scheme utilizing external MOSFET RDSON sensing. For applications requiring power-supply sequencing, the ADP1828 provides a tracking input that allows the output voltage to track during startup, shutdown, and faults. The additional supervisory and control features include thermal overload, undervoltage lockout, and power good. The ADP1828 operates over the -40°C to +125°C junction temperature range and is available in a 20-lead QSOP.

POWERING THE ADP1828 DEMO BOARD**INPUT POWER SOURCE**

1. Before connecting the power source to the ADP1828 Demo Board, make sure that it is turned off. If the input power source includes a current meter, use that meter to monitor the input current.
2. Connect the positive terminal of the power source to the VIN terminal on the evaluation board, and the negative terminal of the power source to the GND terminal
3. If the power source does not include a current meter, connect a current meter in series with the input source voltage.
4. Connect the positive lead (+) of the power source to the ammeter positive (+) connection, the negative lead (-) of the power source to the GND terminal, and the negative lead (-) of the ammeter to the VIN terminal on the board.

OUTPUT LOAD

1. Although the ADP1828 Demo Board can sustain the sudden connection of the load, it is possible to damage the load if it is not properly connected.
2. Make sure that the board is turned off before connecting the load.
 - a) If the load includes an ammeter, or if the current is not measured, connect the load directly to the evaluation board with the positive (+) load connection to the VOUT terminal and negative (-) load connection to the GND terminal.
 - b) If an ammeter is used, connect it in series with the load; connect the positive (+) ammeter terminal to the evaluation board VOUT terminal, the negative (-) ammeter terminal to the positive (+) load terminal, and the negative (-) load terminal to the evaluation board GND terminal

Once the load is connected, make sure that it is set to the proper current before powering the ADP1828 Demo Board.

INPUT AND OUTPUT VOLTMETERS

Measure the input and output voltages with voltmeters.

1. Connect the voltmeter measuring the input voltage with the positive (+) lead connected to the VIN terminal on the test board and the negative lead (-) connected to the GND terminal
2. Connect the voltmeter measuring VOUT with the positive lead (+) connected to the VOUT terminal on the evaluation board and the negative lead (-) connected to the GND terminal.

3. Make sure to connect the voltmeters to the appropriate evaluation board terminals and not to the load or power source themselves.
4. If the voltmeters are not connected directly to the evaluation board at these connection points, the measured voltages will be incorrect due to the voltage drop across the leads connecting the evaluation board to both the source and load.

TURNING ON THE EVALUATION BOARD

Once the power source and loads are connected, the board can be powered for operation. Slowly increase the input power source voltage until the input voltage exceeds the minimum input operating voltage of 3V. If the load is not already enabled, enable the load and check that it is drawing the proper current and that the output voltage maintains voltage regulation.

SCHEMATIC

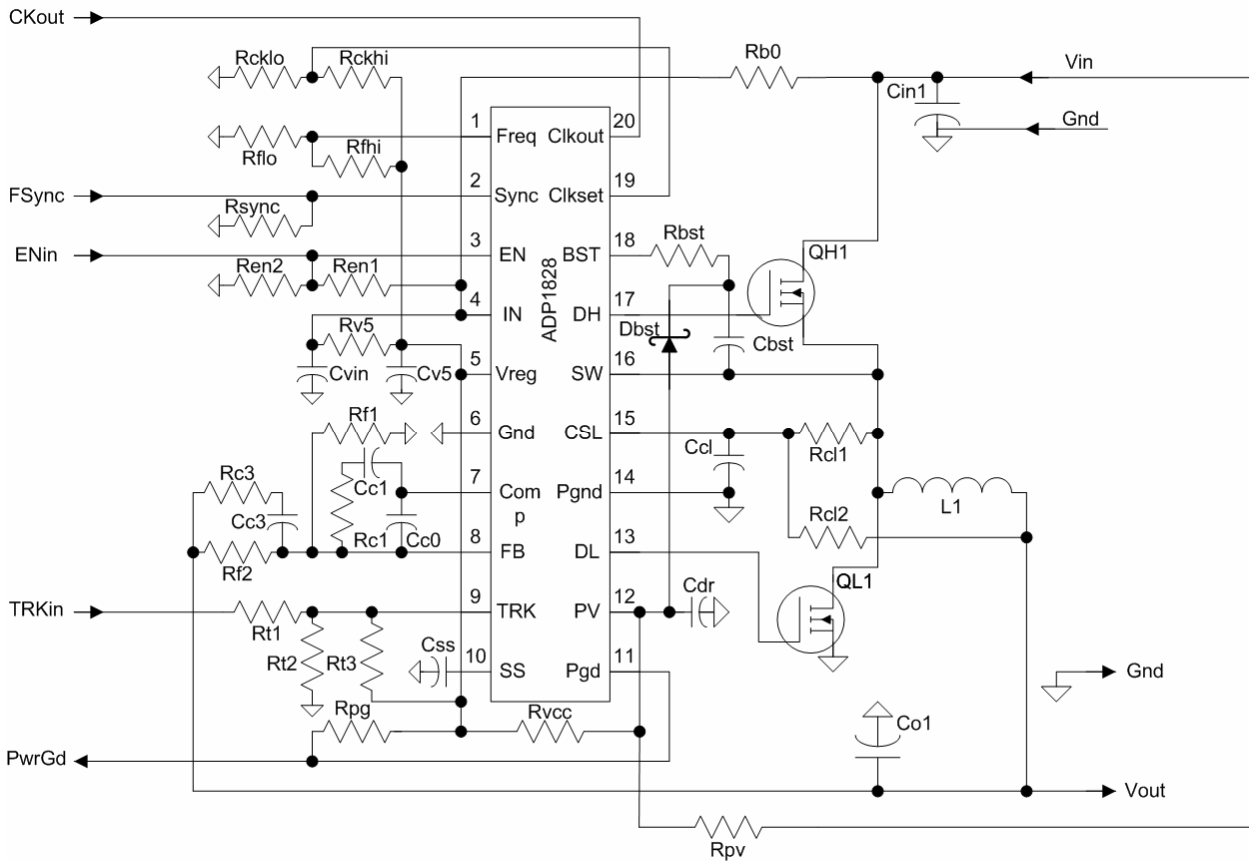

Figure 2. Schematic

BILL OF MATERIALS

Table 1. Bill of Materials

Designator	Part Number	Manufacturer	Value	Package	Comment
U1	ADP1828	Analog Devices		QSOP-20L	Voltage Mode Controller
QH1, QL1	Si5404bdc	Vishay		1206-8	N-Channel MOSFET
L1	DR74-2R2-R	Coiltronics	2.2uH	7.6mm x 7.6mm	Power Inductor / DCR = 9.9mO / Ferrite / Shielded
Cin1	GRM32ER6K476K	Murata	47uF	1210	Input MLCC / X5R / 16V
Co1, Co2	grm32er60j107m	Murata	100uF	1210	Output MLCC / X5R / 6.3V
Cvin, Cv5, Cpv	C2012X7R1C105K	TDK	1uF	0603	MLCC / X7R / 16V
Rf1	Generic 1%	Vishay	6.34k	0402	Feedback Resistor
Rf2	Generic 1%	Vishay	20k	0402	Feedback Resistor
Rc3	Generic 10%	Vishay	76.8ohms	0402	Compensation Resistor
Cc3	Generic 10%	Vishay	860pF	0402	Compensation Capacitor
Rc1	Generic 10%	Vishay	12.1k	0402	Compensation Resistor
Cc1	Generic 10%	Vishay	1.2nF	0402	Compensation Capacitor
Cc0	Generic 10%	Vishay	47pF	0402	Compensation Capacitor
Css	Generic 10%	Vishay	10nF	0402	COG or X7R / Soft Start Capacitor
Rpg	Generic 10%	Vishay	100k	0402	POK1 Resistor
Rvcc, Rb0	Generic 10%	Vishay	10ohms	0402	Decoupling Resistor
Rcl1	Generic 10%	Vishay	5.49k	0402	Current Limit Resistor
Ccl1	Generic 10%	Vishay	33pF	0402	Current Limit Signal Filter Capacitor
Dbst	BAT54	Any		SOD-323	Bootstrap Diode
Cbst	Generic 10%	Vishay	100nF	0402	COG or X7R / Boost Capacitor
Rt1, Rt2, Rpv, Rcl2, Ren2, Rv5, Rflow, Rcklow			NP		
Rt3, Rbst, Ren1, Rsync, Rfhigh, Rckhi			0ohms	0402	

PERFORMANCE

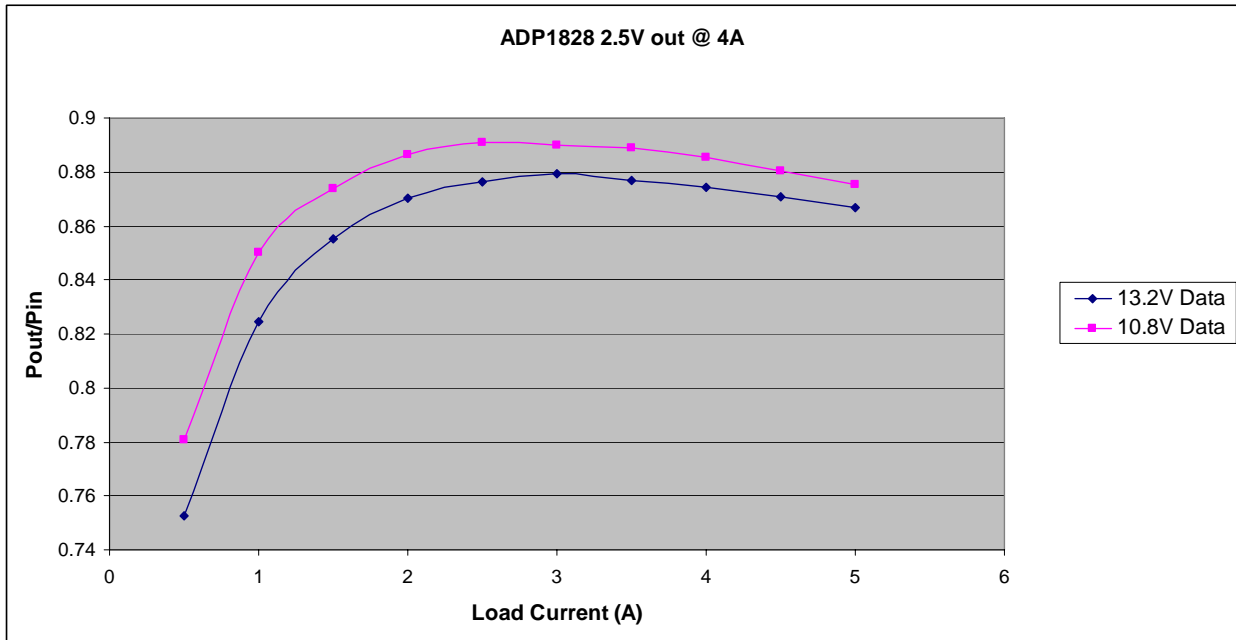

Figure 3. Efficiency

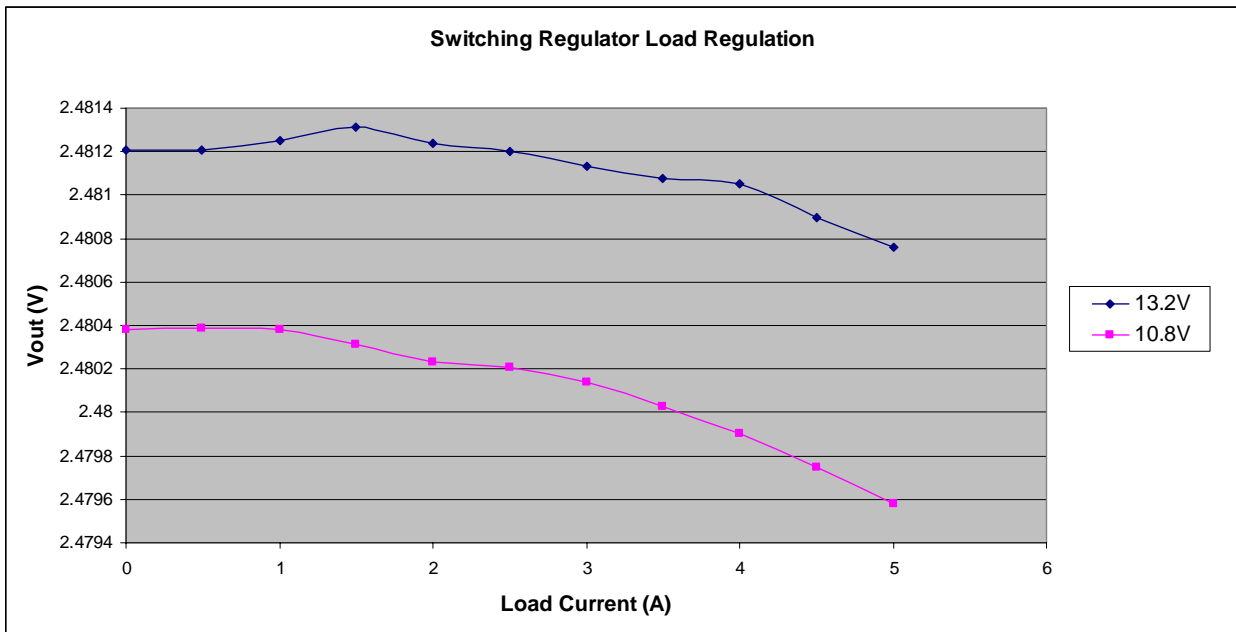

Figure 4. Load Regulation

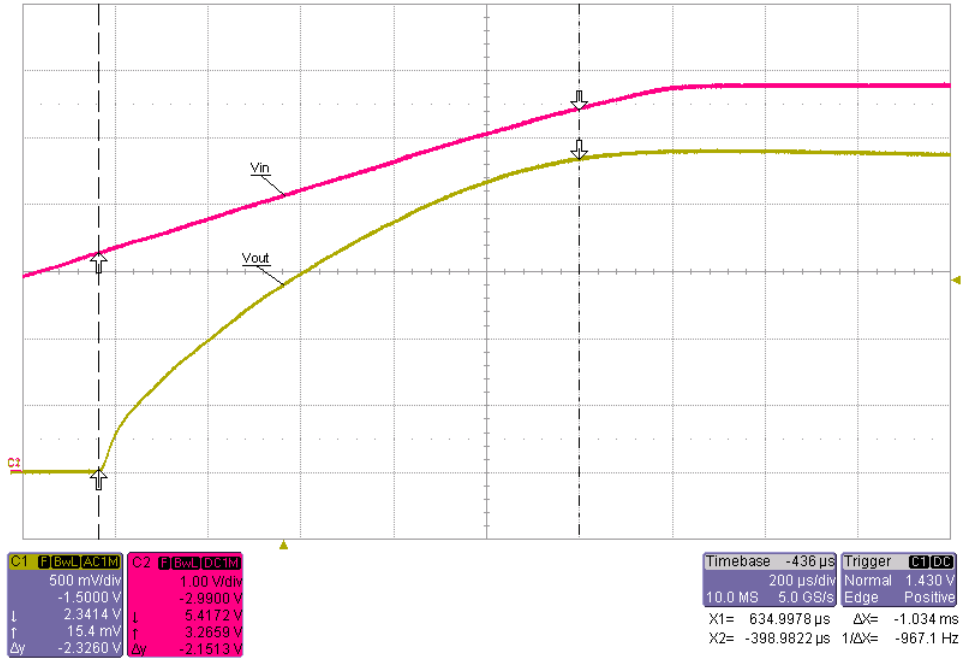

Figure 5. Switching regulator turn on at no load: Ch1 = 2.5 V, Ch2 = Vin

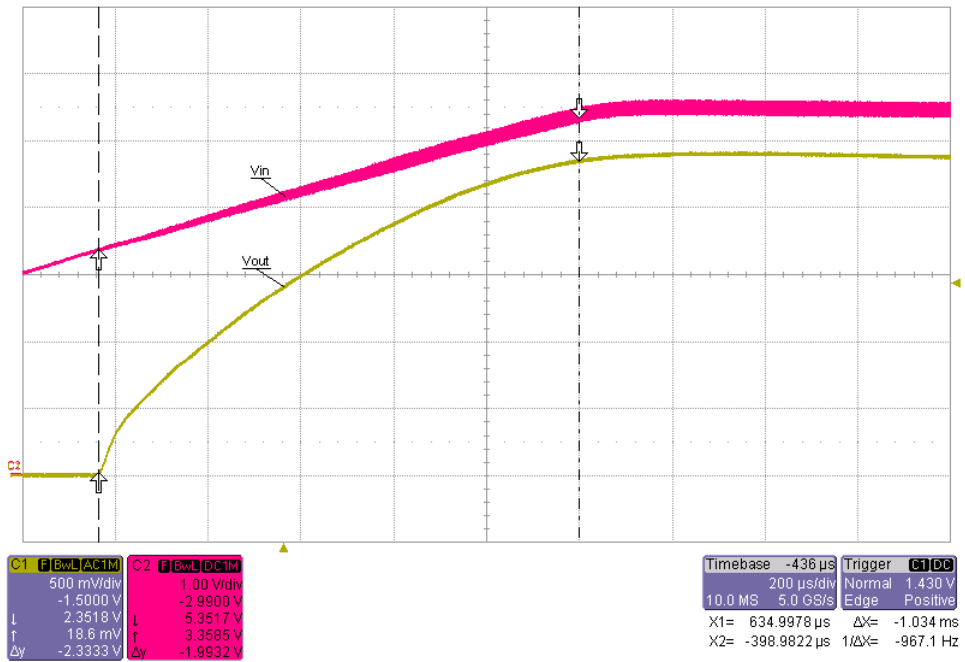

Figure 6. Switching regulator turn on at full load: Ch1 = 2.5 V, Ch2 = Vin

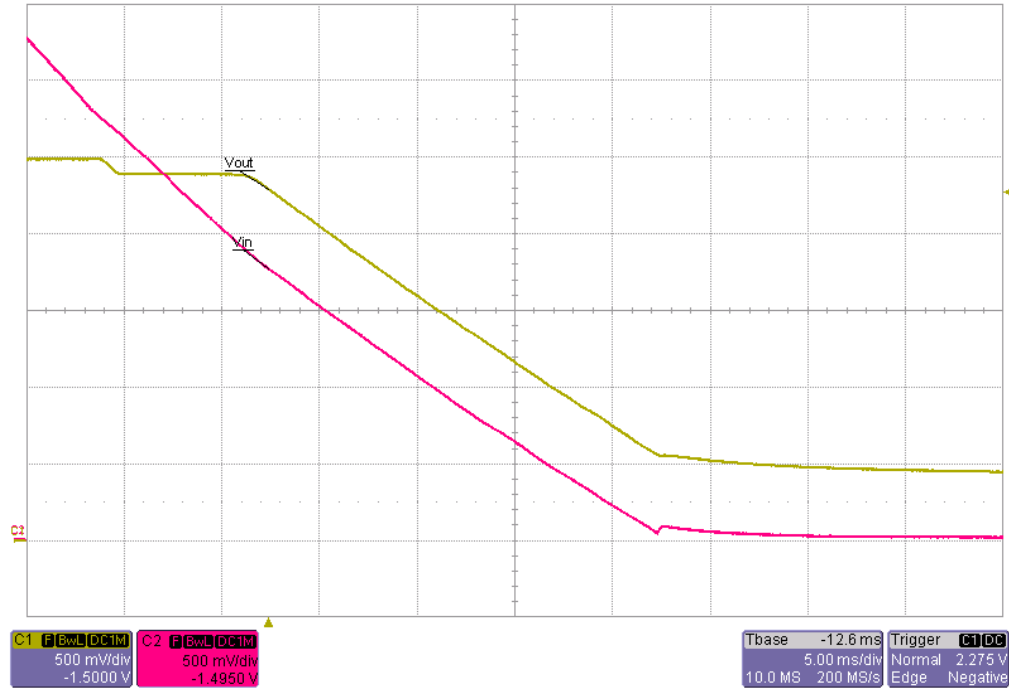

Figure 7. Switching regulator turn off at no load: Ch1 = 3.5 V, Ch2 = Vin

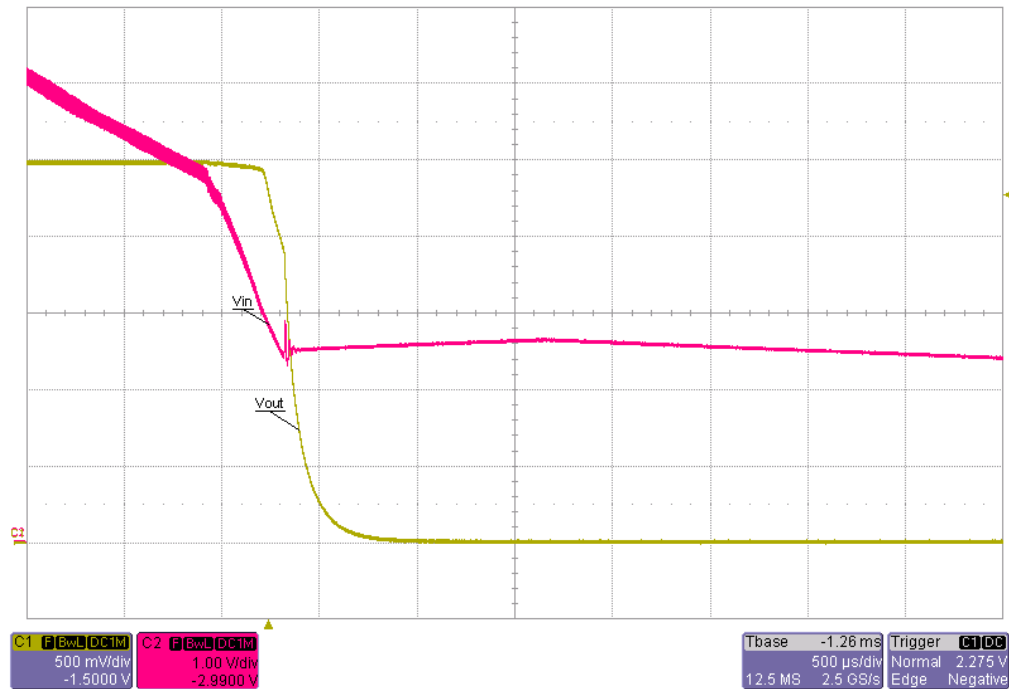

Figure 8. Switching regulator turn off at full load: Ch1 = 2.5 V, Ch2 = Vin

ADP1828 Demo Board Documentation

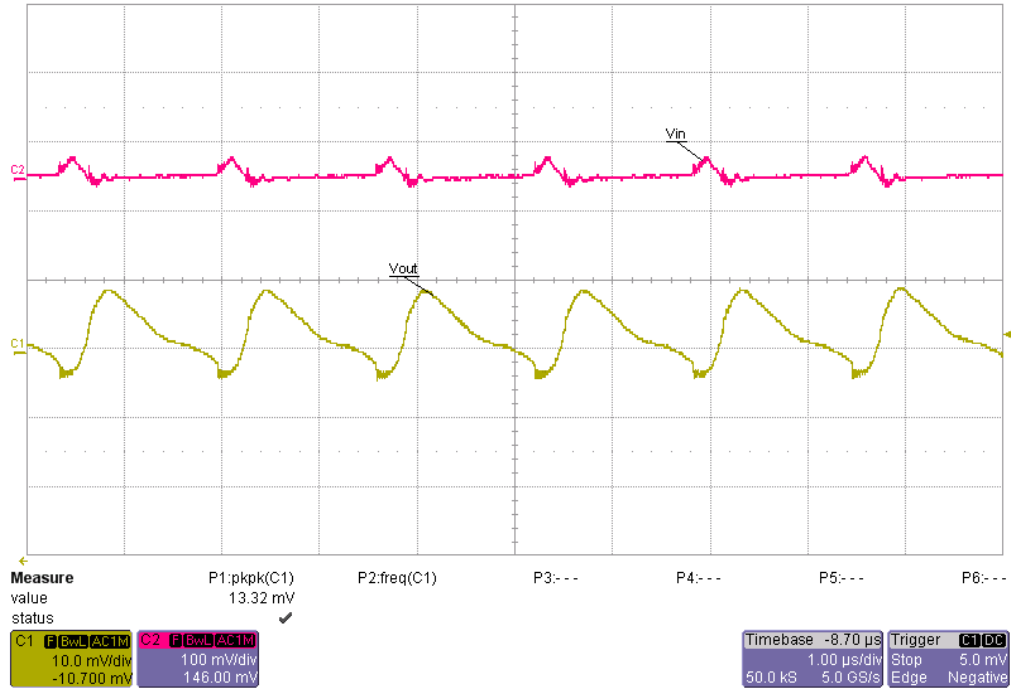

Figure 9. Vin and Vout Ripple. Load current = 0A. Vin = 13.2V

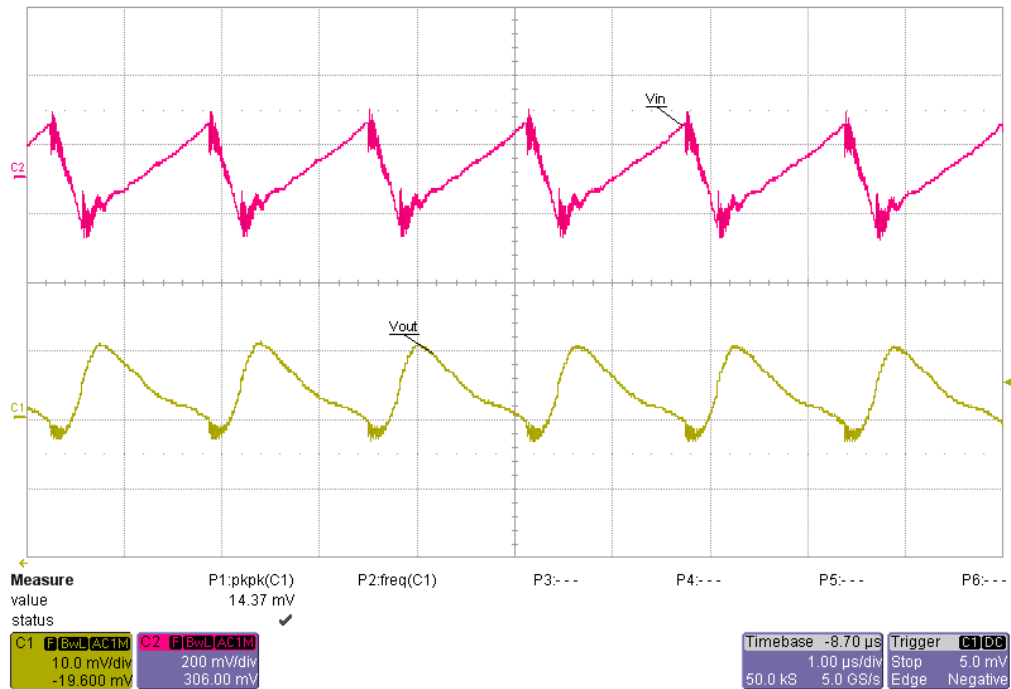

Figure 10. Vin and Vout Ripple. Load Current = 4A. Vin = 13.2V

ADP1828 Demo Board Documentation

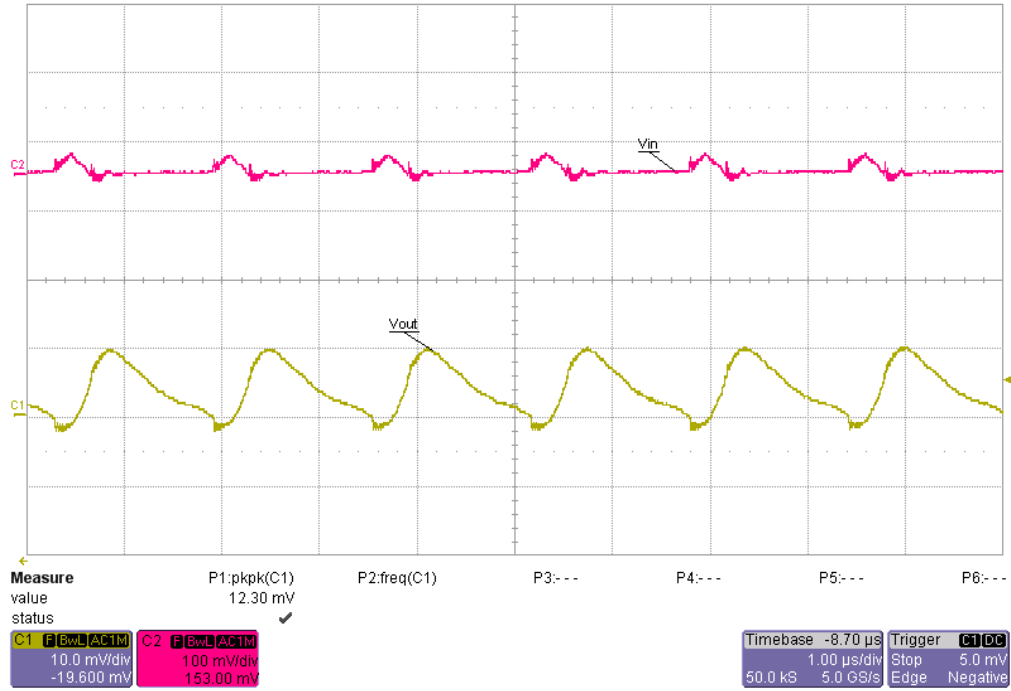

Figure 11. Vin and Vout Ripple. Load Current=0A Vin=10.8V

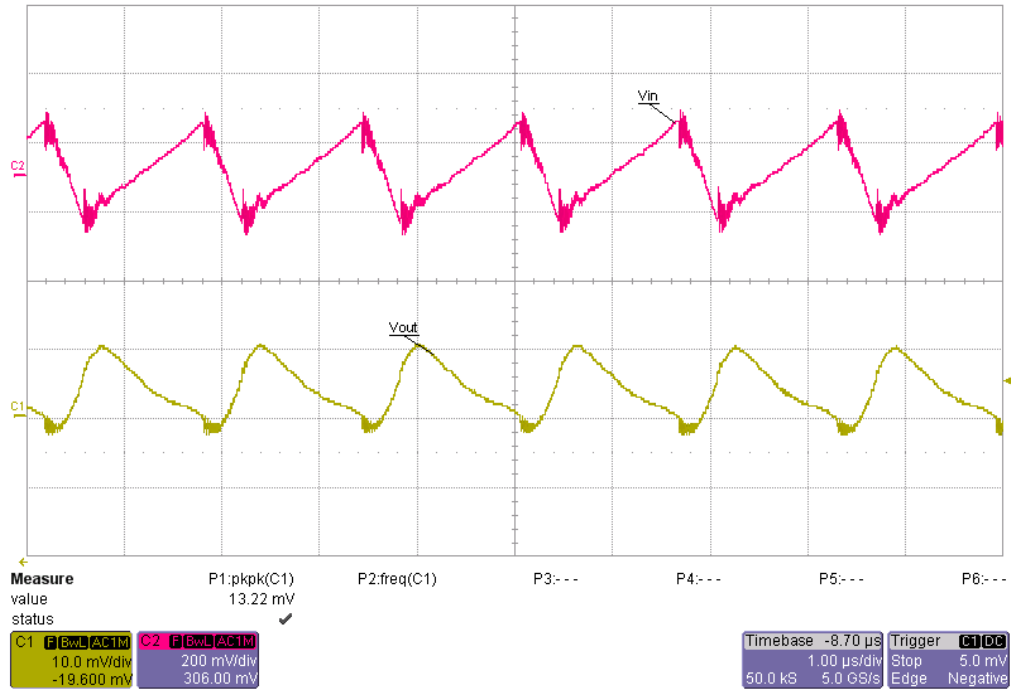

Figure 12. Vin and Vout Ripple. Load Current = 4A. Vin = 10.8V

ADP1828 Demo Board Documentation

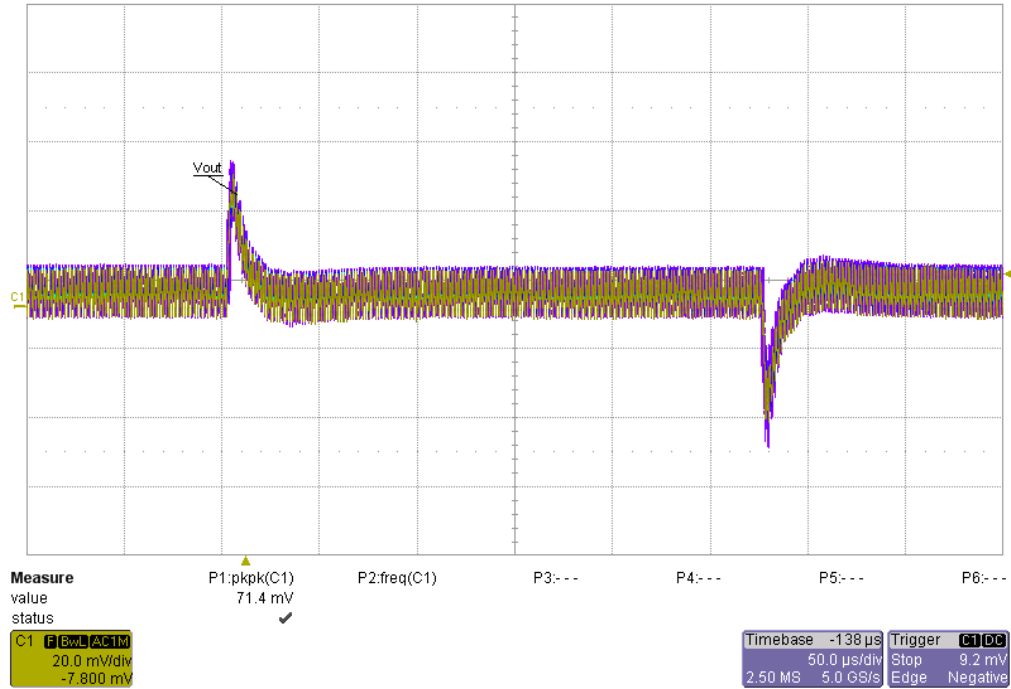

Figure 13. Transient, 2A Load Step (2A \rightarrow 4A), 2A Load Release (4A \rightarrow 2A), V_{in} =10.8 (infinite persistence)

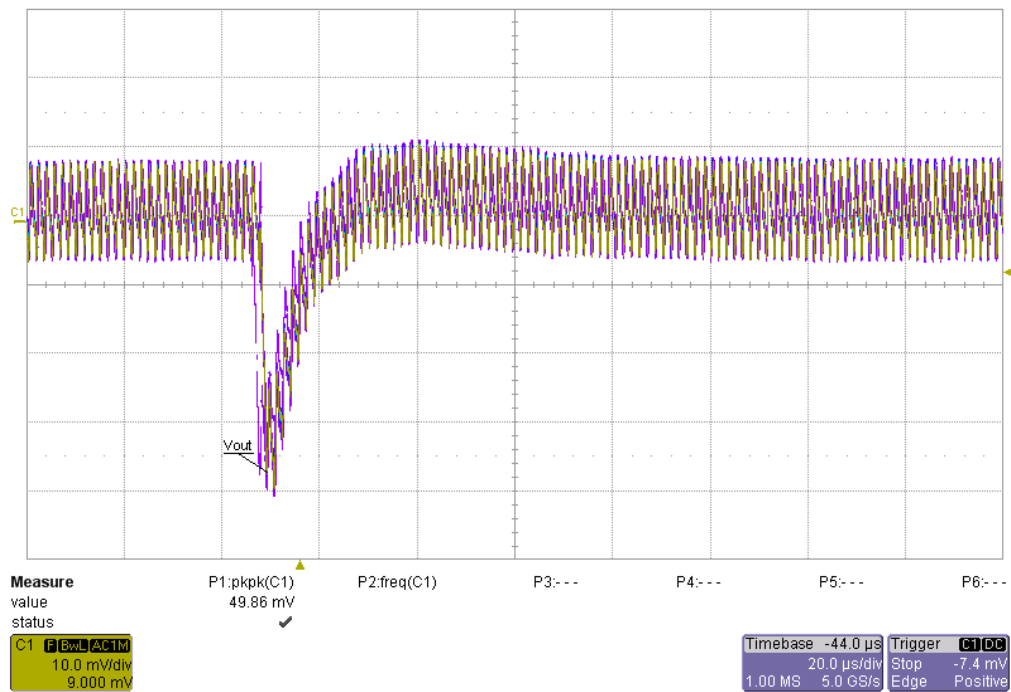

Figure 14. 2A Load Step (2A \rightarrow 4A), V_{in} =13.2V (infinite persistence)

ADP1828 Demo Board Documentation

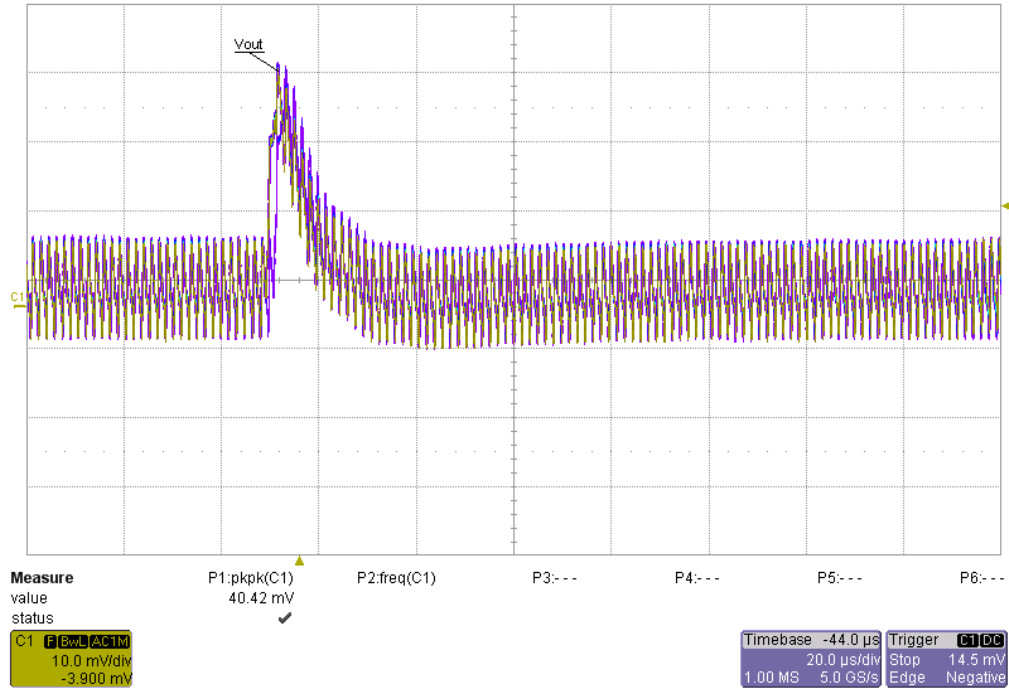

Figure 15. 2A Load Release (4A-> 2A). $V_{in} = 13.2V$ (infinite persistence)

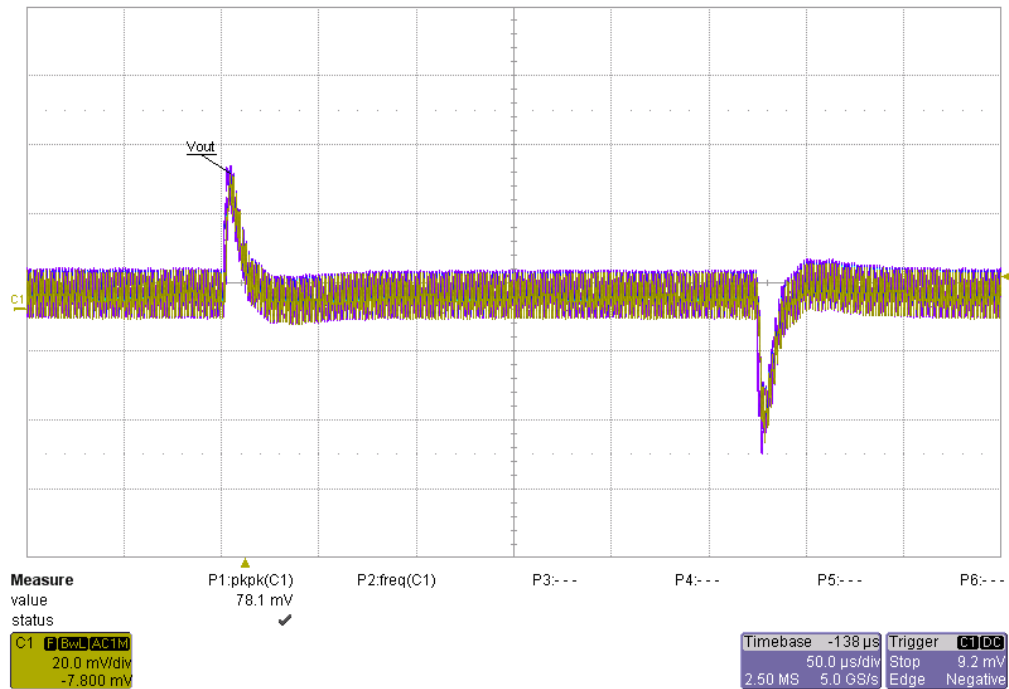

Figure 16. Load Transient. 2A Load Step (2A -> 4A). 2A Load Release (4A ->2A). $V_{in}=10.8V$

Figure 17. (infinite persistence)

ADP1828 Demo Board Documentation

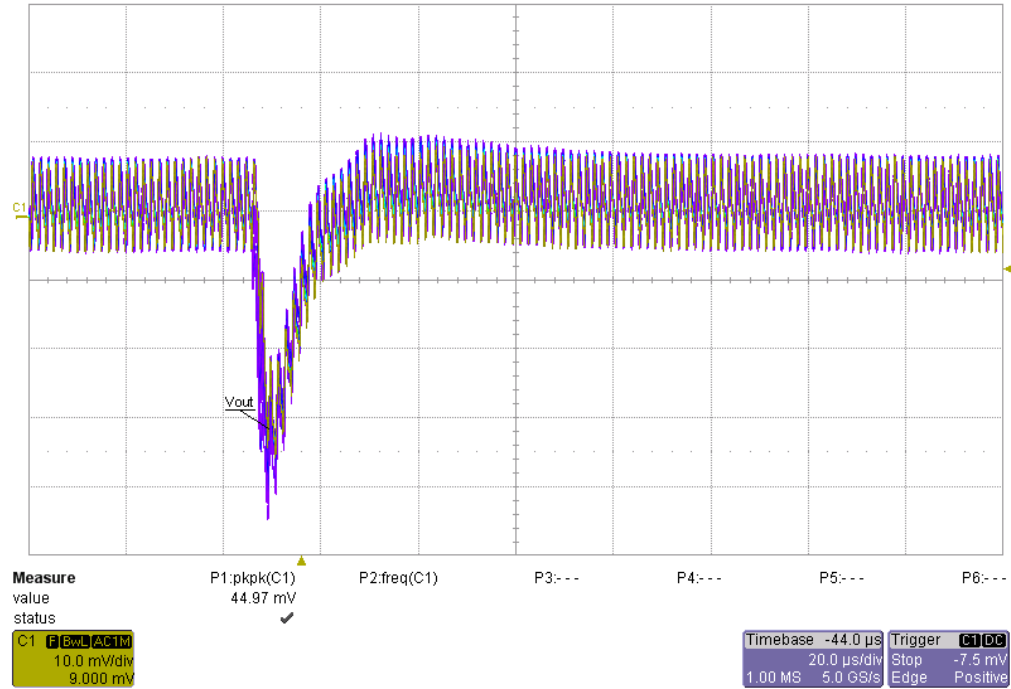

Figure 18. 2A Load Step (2A \rightarrow 4A). V_{in} =10.8V (infinite persistence)

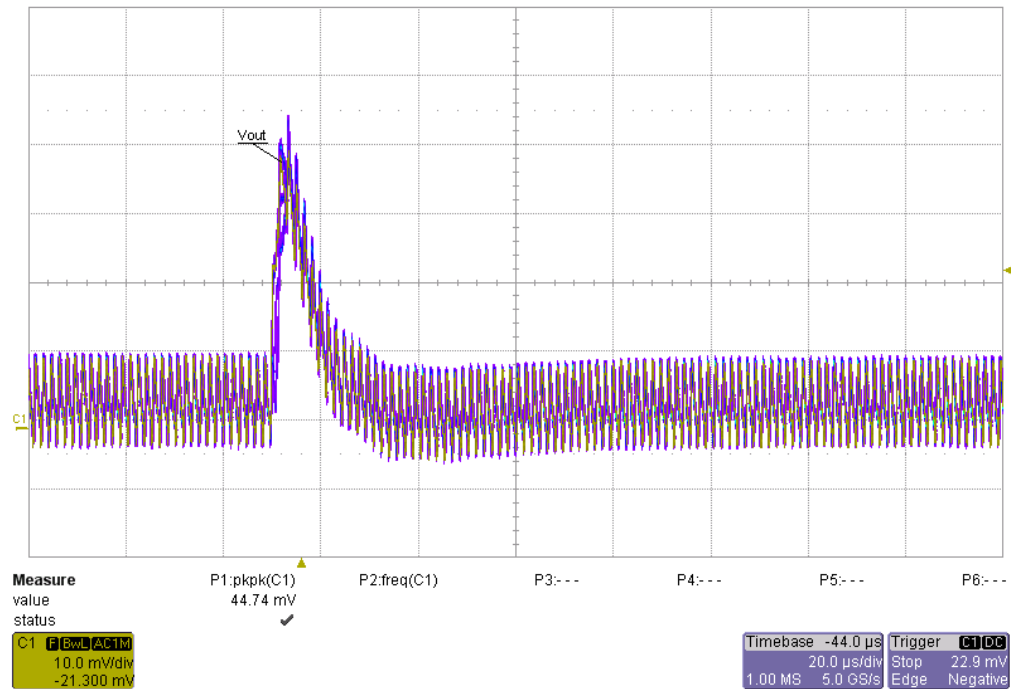

Figure 19. 2A Load Release (4A \rightarrow 2A). V_{in} =10.8V (infinite persistence)

ADP1828 Demo Board Documentation

PCB LAYOUT FILES

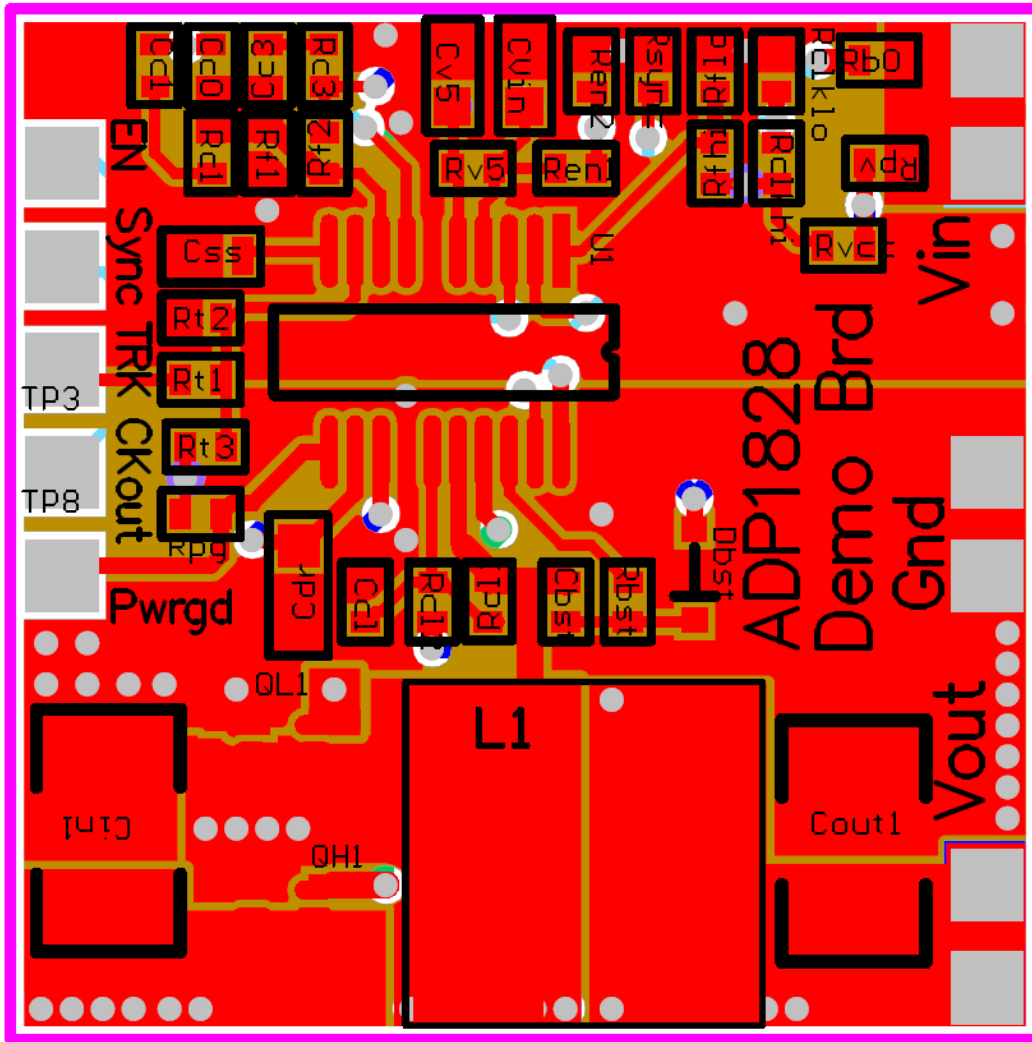

Figure 20. Top PCB Layer

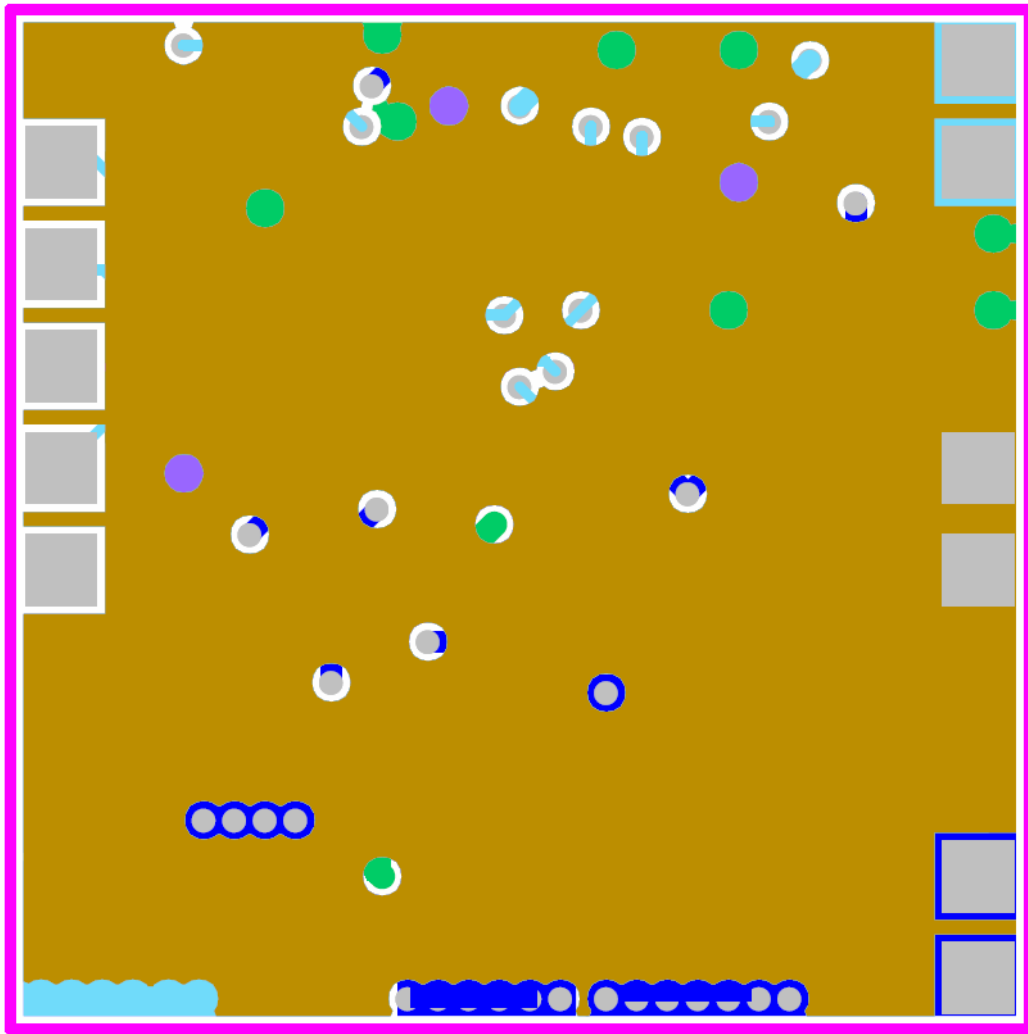

Figure 21. Second PCB Layer

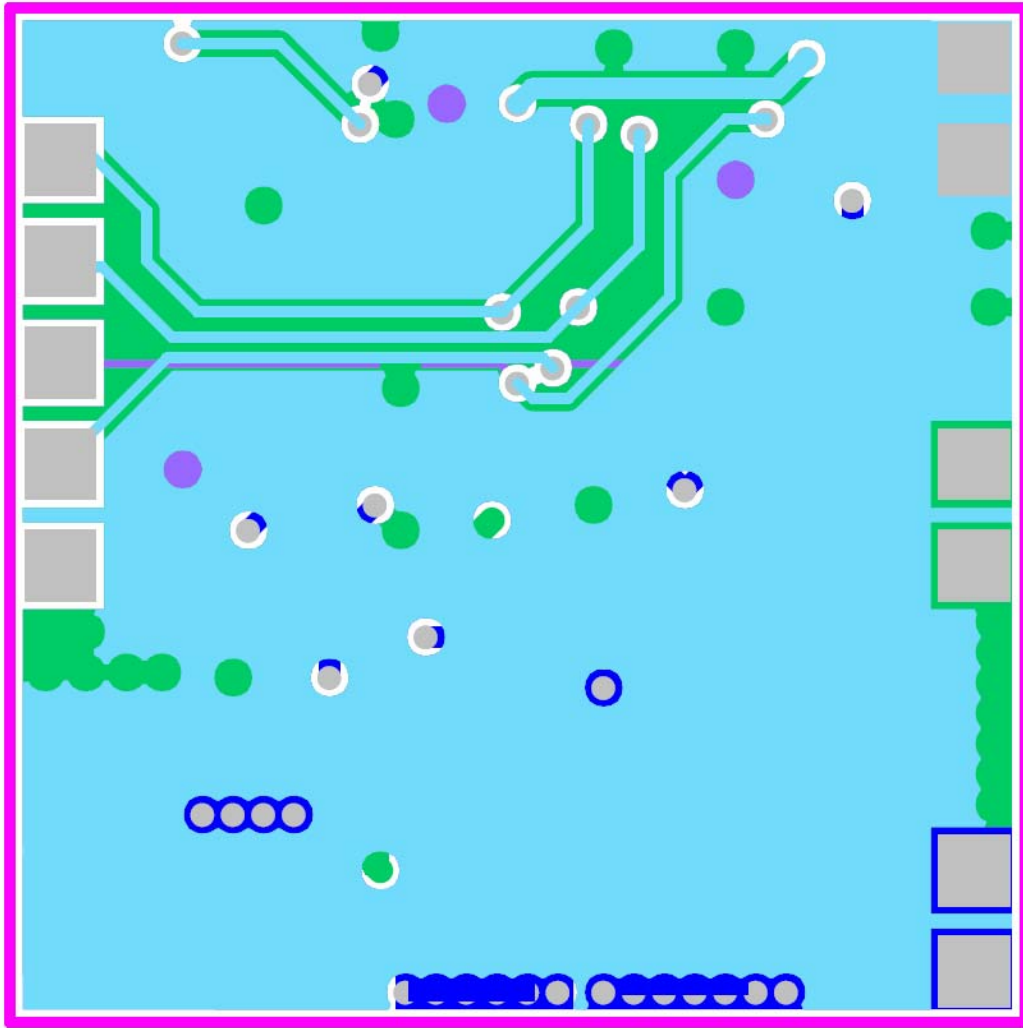

Figure 22. Third PCB Layer

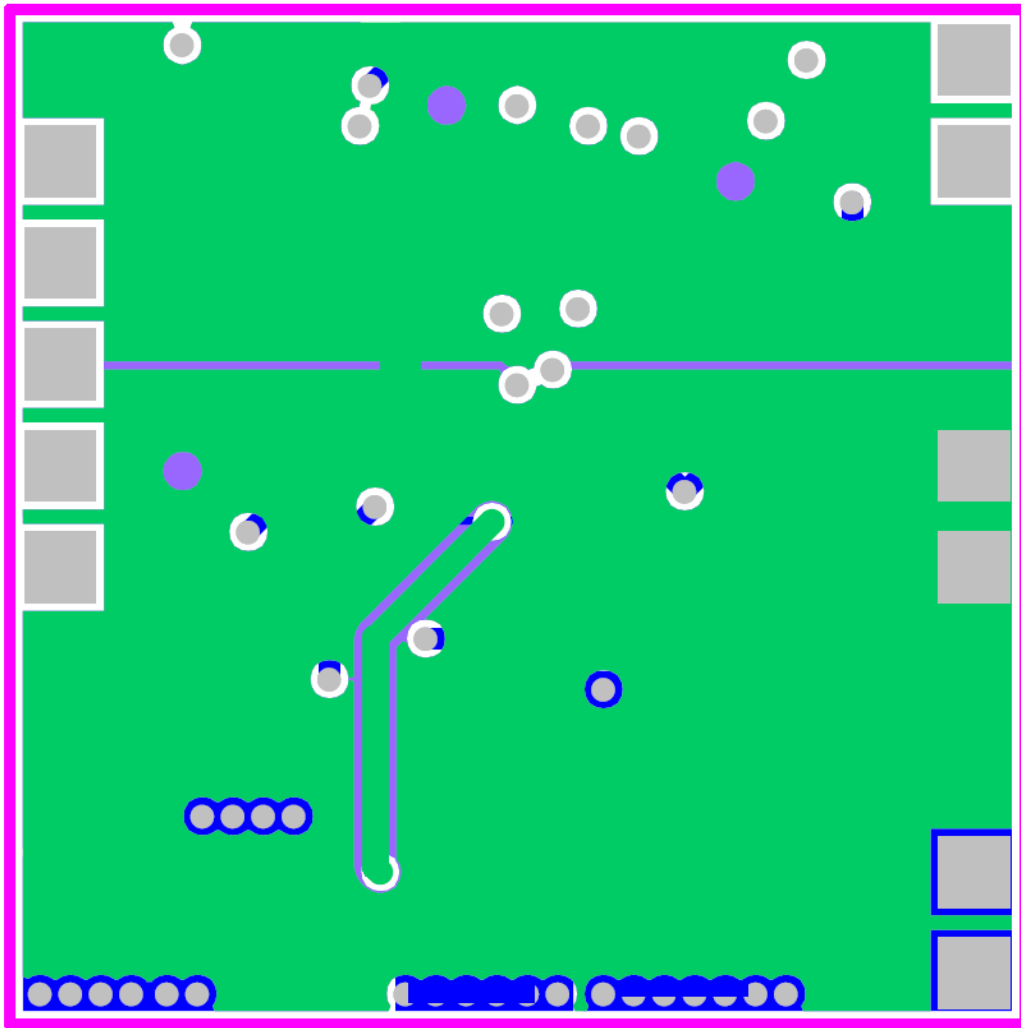

Figure 23. Fourth PCB Layer

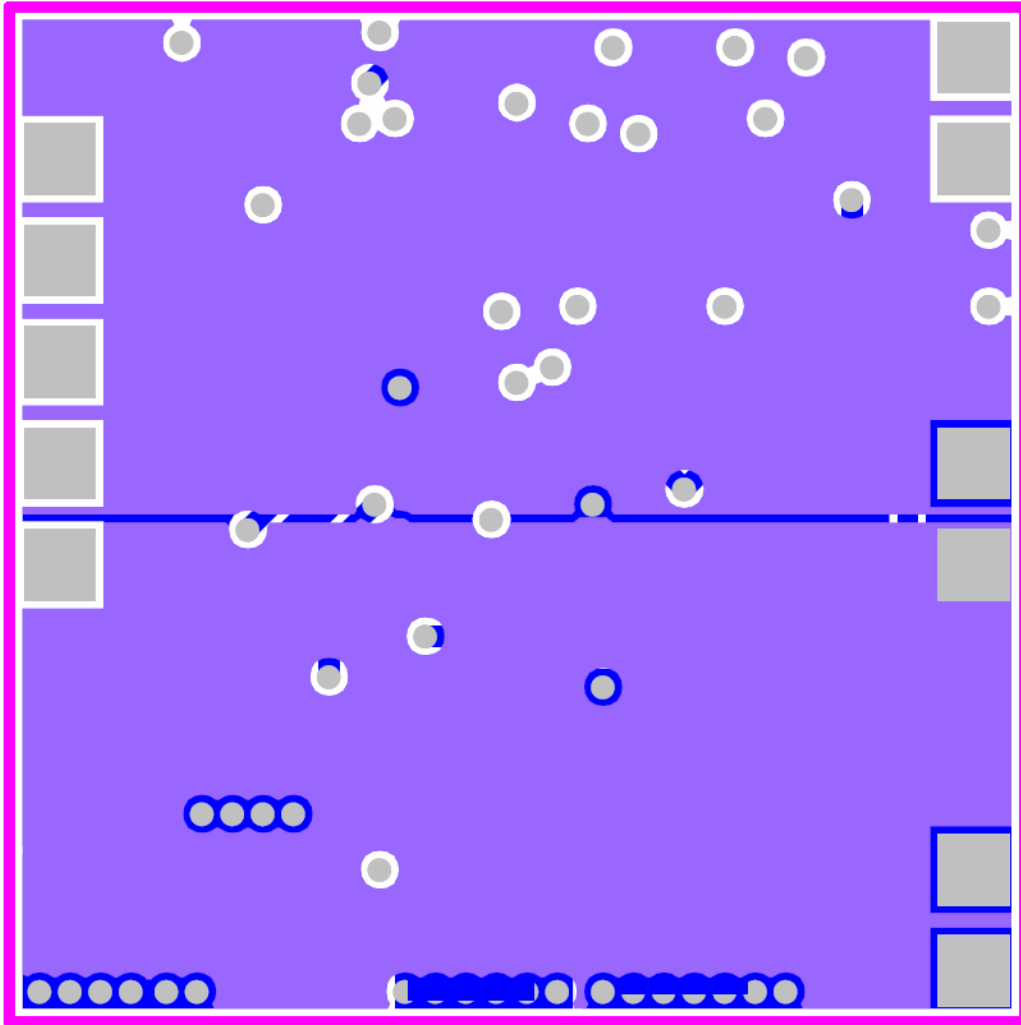

Figure 24. Fifth PCB Layer

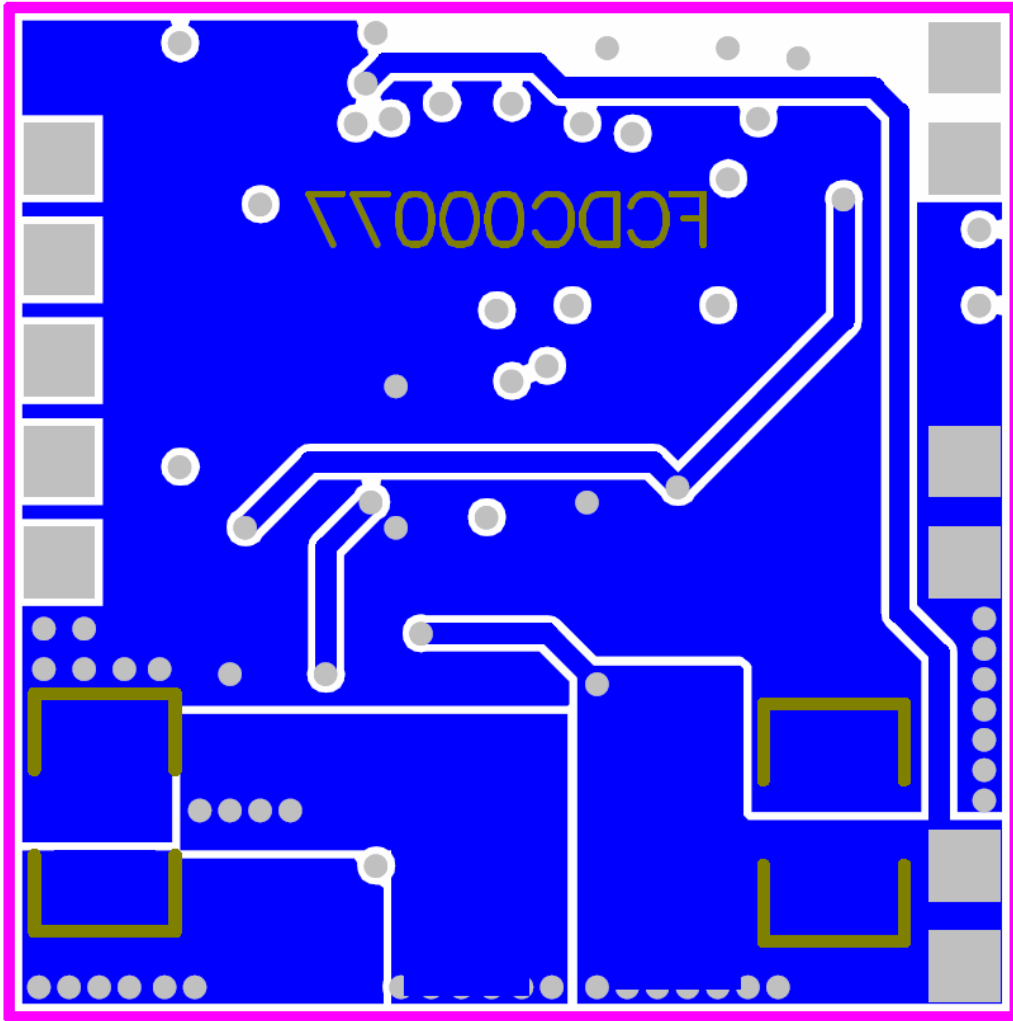

Figure 25. Sixth and Bottom PCB Layer

NOTES:

©2007 Analog Devices, Inc. All rights reserved. Trademarks and registered trademarks are the property of their respective owners. EB0561



www.analog.com