

Evaluation of the ADRF5345 High Linearity, Silicon SP4T Switch, 1.8 GHz to 3.8 GHz

FEATURES

- ▶ Full featured evaluation board for the [ADRF5345](#)
- ▶ Easy connection to test equipment
- ▶ Thru line for calibration

EQUIPMENT NEEDED

- ▶ DC power supplies
- ▶ Network analyzer

GENERAL DESCRIPTION

The ADRF5345 is a high linearity, single-pole, four-throw (SP4T) switch manufactured in the silicon process.

This user guide describes the ADRF5345-EVALZ evaluation board, designed to simply evaluate the features and performance of the ADRF5345. A photograph of the evaluation board is shown in [Figure 1](#).

The ADRF5345 data sheet provides full specifications for the ADRF5345. Consult the ADRF5345 data sheet in conjunction with this user guide when using the ADRF5345-EVALZ.

ADRF5345-EVALZ EVALUATION BOARD PHOTOGRAPH

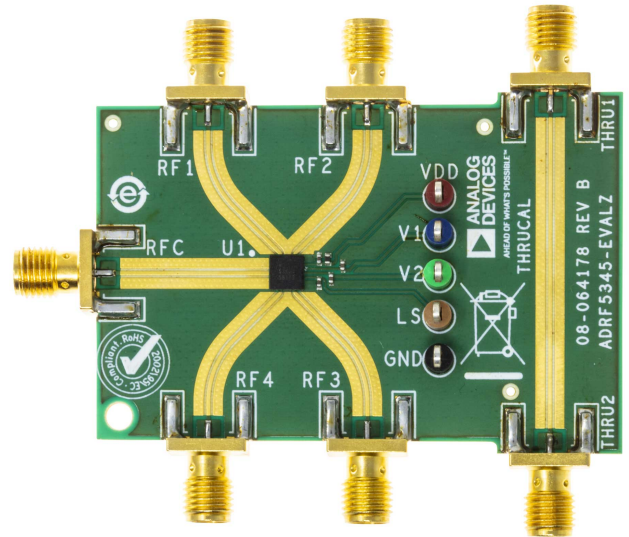

Figure 1. Evaluation Board Photograph

001

TABLE OF CONTENTS

Features.....	1	RF Inputs and Outputs	4
Equipment Needed.....	1	Test Procedure.....	5
General Description.....	1	Biasing Sequence.....	5
ADRF5345-EVALZ Evaluation Board Photograph	1	Expected Results.....	6
Evaluation Board Hardware.....	3	Evaluation Board Schematic and Artwork.....	7
Overview.....	3	Ordering Information.....	8
Board Layout.....	3	Bill of Materials.....	8
Power Supply and Control Inputs.....	3		

REVISION HISTORY**12/2021—Revision 0: Initial Version**

EVALUATION BOARD HARDWARE

OVERVIEW

The ADRF5345-EVALZ is a connectorized board, assembled with the [ADRF5345](#) and its application circuitry. All components are placed on the primary side of ADRF5345-EVALZ. An assembly drawing for the ADRF5345-EVALZ is shown in [Figure 10](#), and an evaluation board schematic is shown in [Figure 9](#).

BOARD LAYOUT

The ADRF5345-EVALZ is designed using RF circuit design techniques on an 8-layer printed circuit board (PCB). The PCB stack-up is shown in [Figure 2](#).

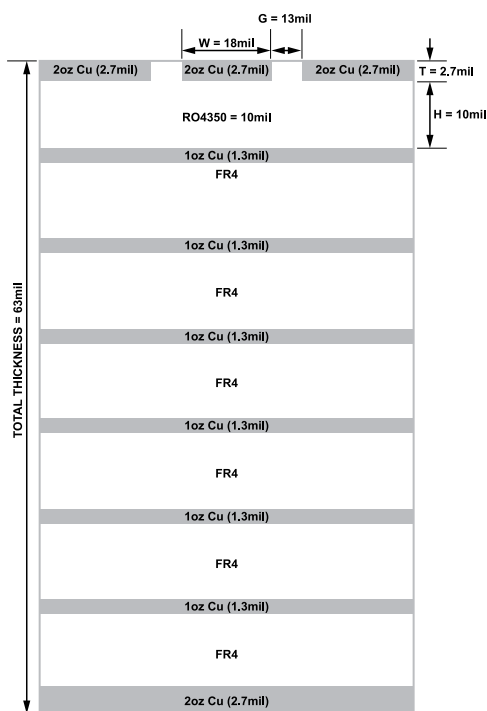

Figure 2. Evaluation Board Stack-Up

The outer copper layers are 2 oz (2.7 mil) thick and the inner layers are 1 oz (1.3 mil) thick.

The top dielectric material is 10 mil Rogers 4350B, which provides 50 Ω controlled impedance and optimizes the high frequency performance. All RF traces are routed on the top layer, and the second layer is used as the ground plane for RF transmission lines. The remaining six layers are also ground planes filled with FR4 material to manage the thermal rise during high power operations, and are supported with dense and filled vias to the PCB bottom for thermal relief. The overall board thickness is approximately 63 mil for mechanical strength.

The RF transmission lines are designed using a coplanar waveguide (CPWG) model with a width of 18 mil and ground spacing of 13 mil to have a characteristic impedance of 50 Ω . Ground via fences are arranged on both sides of a coplanar waveguide to improve isolation between nearby RF lines and other signal lines.

The exposed ground pad of the ADRF5345, which is soldered on the PCB ground pad, is the main thermal conduit for heat dissipation. The PCB ground pad is densely populated with filled, through vias to provide the lowest possible thermal resistance path from the top to the bottom of the PCB. The connections from the package ground leads to ground are kept as short as possible.

POWER SUPPLY AND CONTROL INPUTS

The ADRF5345-EVALZ has one power supply input, three control inputs, and a ground, as shown in [Table 1](#). The dc test points are populated on VDD, V1, V2, LS, and GND. A single 5 V supply is connected to the dc test points on VDD. Ground reference can be connected to GND. Connect the control inputs, V1, V2, and LS, to 3.3 V or 0 V. The typical total current consumption for the ADRF5345 is 2 mA.

The VDD supply pin of the ADRF5345 is decoupled with 100 pF and 4.7 μ F capacitors, and the control pins of the ADRF5345 are decoupled with a 100 pF capacitor.

Table 1. Power Supply and Control Inputs

Test Points	Description
VDD	Supply voltage
V1	Control Input 1
V2	Control Input 2
LS	Logic select
GND	Ground

EVALUATION BOARD HARDWARE

RF INPUTS AND OUTPUTS

The ADRF5345-EVALZ has seven edge-mounted, Subminiature A (SMA) connectors for the RF inputs and outputs, as shown in [Table 2](#).

Table 2. RF Inputs and Outputs

SMA Connectors	Description
RFC	RF common port
RF1	RF Throw Port 1
RF2	RF Throw Port 2
RF3	RF Throw Port 3
RF4	RF Throw Port 4
THRU1	Thru line input and output
THRU2	Thru line input and output

The through calibration line, connecting the THRU1 and THRU2 RF connectors, calibrates out the board loss effects from the measurements of the ADRF5345-EVALZ to determine the device performance at the pins of the IC. [Figure 3](#) shows the typical board

loss for the ADRF5345-EVALZ at room temperature, as well as the embedded and de-embedded insertion loss for the [ADRF5345](#).

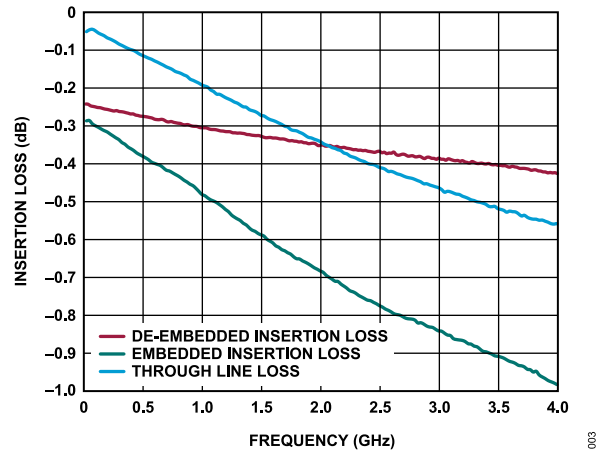

Figure 3. Insertion Loss vs. Frequency

TEST PROCEDURE

BIASING SEQUENCE

To bias up the ADRF5345-EVALZ, perform the following steps:

1. Ground the GND test point.
2. Bias up the VDD1 test point.
3. Bias up the V1, V2, and LS test points.
4. Apply an RF input signal.

The ADRF5345-EVALZ is shipped fully assembled and tested. Figure 4 provides a basic test setup diagram to evaluate the s-parameters using a network analyzer. Perform the following steps to complete the test setup and verify the operation of the ADRF5345-EVALZ:

1. Connect the GND test point to the ground terminal of the power supply.
2. Connect the VDD test point to the voltage output terminal of the 5 V supply. Note that the current must be 2 mA.
3. Connect the V1, V2, and LS test points to the voltage output terminal of the 3.3 V supply. The ADRF5345 can be configured in different modes by connecting the control test points to 3.3 V or 0 V, as shown in Table 3.
4. Connect a calibrated network analyzer to the RFC, RF1, RF2, RF3, and RF4 SMA connectors. If network analyzer port count is not enough, terminate unused RF ports with 50 Ω. Sweep the frequency from 10 MHz to 4 GHz and set the power to -5 dBm.
5. The ADRF5345-EVALZ is expected to have an insertion loss of 0.4 dB at 3.5 GHz. See the expected results in Figure 5.

Additional test equipment is needed to fully evaluate the device functions and performance.

For third-order intercept point evaluation, use two signal generators and a spectrum analyzer. A high isolation power combiner is also recommended.

For power compression and power handling evaluations, use a 2-channel power meter and a signal generator. A high enough power amplifier is also recommended at the input. Test accessories, such as couplers and attenuators, must have enough power handling.

The ADRF5345-EVALZ comes with a support plate attached to the bottom side. To ensure maximum heat dissipation and to reduce thermal rise on the board during high power evaluations, this support plate must be attached to a heat sink using thermal grease.

Note that the measurements performed at the SMA connectors of the ADRF5345-EVALZ include the losses of the SMA connectors and the PCB. The thru line must be measured to calibrate out the effects on the ADRF5345-EVALZ. The thru line is the summation of an RF input line and an RF output line that are connected to the device and equal in length.

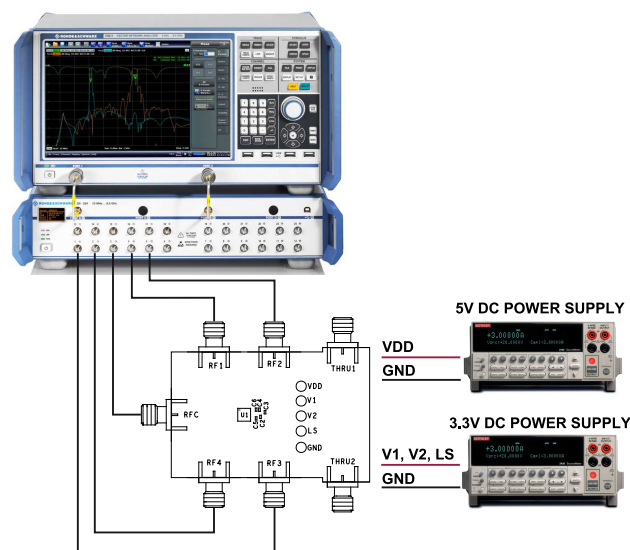

Figure 4. Test Setup Diagram

Table 3. Control Voltage Truth Table

Digital Control Inputs			RFx Paths			
LS	V1	V2	RF1 to RFC	RF2 to RFC	RF3 to RFC	RF4 to RFC
Low	Low	Low	Insertion loss (on)	Isolation (off)	Isolation (off)	Isolation (off)
Low	High	Low	Isolation (off)	Insertion loss (on)	Isolation (off)	Isolation (off)
Low	Low	High	Isolation (off)	Isolation (off)	Insertion loss (on)	Isolation (off)
Low	High	High	Isolation (off)	Isolation (off)	Isolation (off)	Insertion loss (on)
High	Low	Low	Isolation (off)	Isolation (off)	Isolation (off)	Insertion loss (on)
High	High	Low	Isolation (off)	Isolation (off)	Insertion loss (on)	Isolation (off)
High	Low	High	Isolation (off)	Insertion loss (on)	Isolation (off)	Isolation (off)
High	High	High	Insertion loss (on)	Isolation (off)	Isolation (off)	Isolation (off)

TEST PROCEDURE

EXPECTED RESULTS

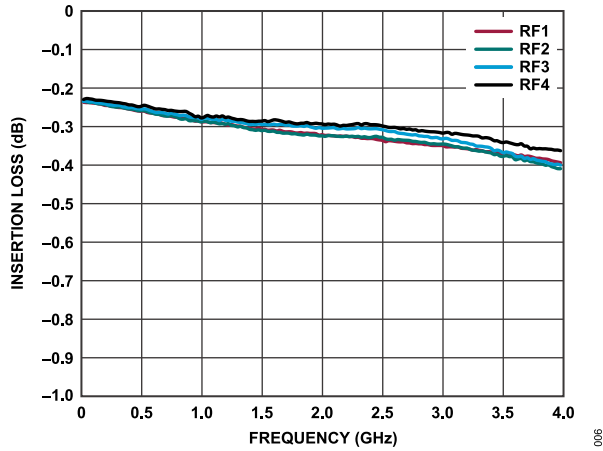

Figure 5. Insertion Loss for RFC to RFx Selected vs. Frequency

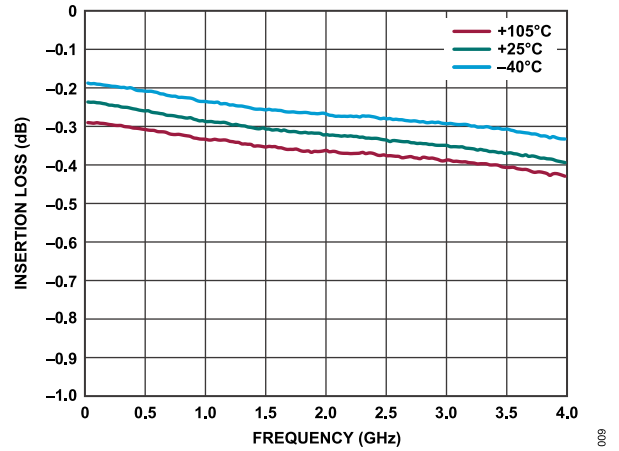

Figure 7. Insertion Loss for RFC to RF1 Selected vs. Frequency over Various Temperatures

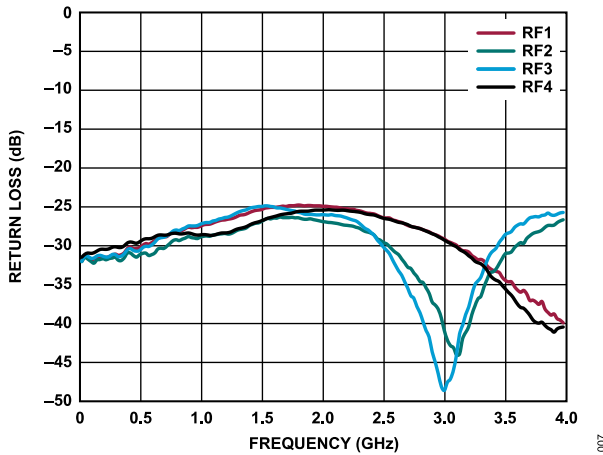

Figure 6. Return Loss for RFC when RFx Selected vs. Frequency

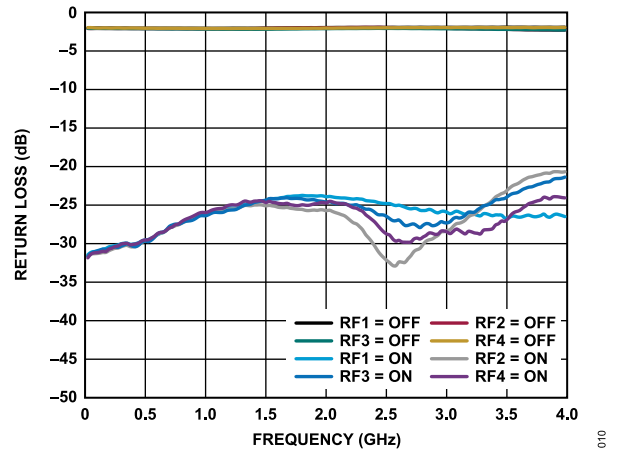

Figure 8. Return Loss for RFC when RFx Selected vs. Frequency

EVALUATION BOARD SCHEMATIC AND ARTWORK

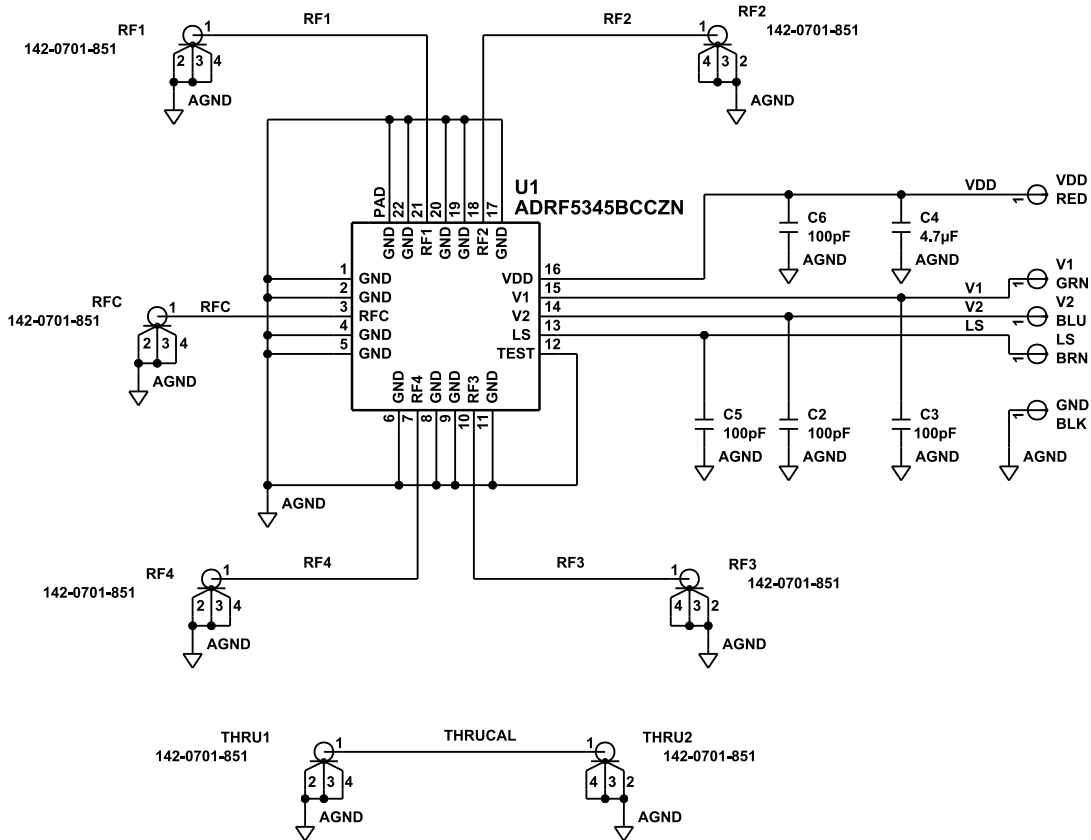

Figure 9. ADRF5345-EVALZ Evaluation Board Schematic

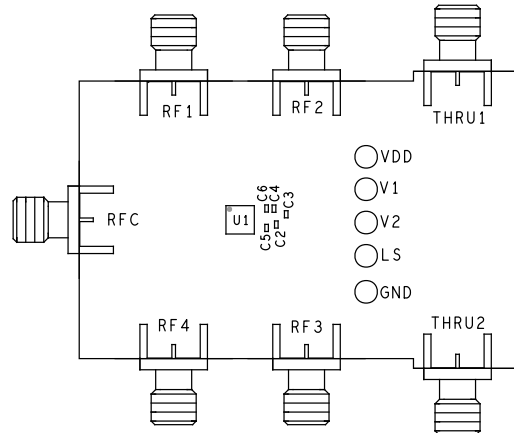

Figure 10. ADRF5345-EVALZ Evaluation Board Assembly Diagram

012

011

ORDERING INFORMATION

BILL OF MATERIALS

Table 4. Bill of Materials for ADRF5345-EVALZ

Qty	Reference Designator	Description	Manufacturer	Part Number
4	C2, C3, C5, C6	Capacitors, 100 pF, 50 V, C0402 package	KEMET	C0402C101J5GACTU
1	C4	Capacitor, 4.7 μ F, 50 V, C0402 package	KEMET	
7	RFC, RF1, RF2, RF3, RF4, THRU1, and THRU2	Edge mount SMA Connectors	Cinch	142-0701-851
5	GND, LS, V1, V2, and VDD	Surface-mount test points	Keystone Electronics	5016
1	U1	High linearity, silicon SP4T switch, 1.8 GHz to 3.8 GHz	Analog Devices, Inc.	ADRF5345BBCZN
1	PCB	ADRF5345-EVALZ	Analog Devices	BR-064178

**ESD Caution**

ESD (electrostatic discharge) sensitive device. Charged devices and circuit boards can discharge without detection. Although this product features patented or proprietary protection circuitry, damage may occur on devices subjected to high energy ESD. Therefore, proper ESD precautions should be taken to avoid performance degradation or loss of functionality.

Legal Terms and Conditions

By using the evaluation board discussed herein (together with any tools, components documentation or support materials, the "Evaluation Board"), you are agreeing to be bound by the terms and conditions set forth below ("Agreement") unless you have purchased the Evaluation Board, in which case the Analog Devices Standard Terms and Conditions of Sale shall govern. Do not use the Evaluation Board until you have read and agreed to the Agreement. Your use of the Evaluation Board shall signify your acceptance of the Agreement. This Agreement is made by and between you ("Customer") and Analog Devices, Inc. ("ADI"), with its principal place of business at Subject to the terms and conditions of the Agreement, ADI hereby grants to Customer a free, limited, personal, temporary, non-exclusive, non-sublicensable, non-transferable license to use the Evaluation Board FOR EVALUATION PURPOSES ONLY. Customer understands and agrees that the Evaluation Board is provided for the sole and exclusive purpose referenced above, and agrees not to use the Evaluation Board for any other purpose. Furthermore, the license granted is expressly made subject to the following additional limitations: Customer shall not (i) rent, lease, display, sell, transfer, assign, sublicense, or distribute the Evaluation Board; and (ii) permit any Third Party to access the Evaluation Board. As used herein, the term "Third Party" includes any entity other than ADI, Customer, their employees, affiliates and in-house consultants. The Evaluation Board is NOT sold to Customer; all rights not expressly granted herein, including ownership of the Evaluation Board, are reserved by ADI. CONFIDENTIALITY. This Agreement and the Evaluation Board shall all be considered the confidential and proprietary information of ADI. Customer may not disclose or transfer any portion of the Evaluation Board to any other party for any reason. Upon discontinuation of use of the Evaluation Board or termination of this Agreement, Customer agrees to promptly return the Evaluation Board to ADI. ADDITIONAL RESTRICTIONS. Customer may not disassemble, decompile or reverse engineer chips on the Evaluation Board. Customer shall inform ADI of any occurred damages or any modifications or alterations it makes to the Evaluation Board, including but not limited to soldering or any other activity that affects the material content of the Evaluation Board. Modifications to the Evaluation Board must comply with applicable law, including but not limited to the RoHS Directive. TERMINATION. ADI may terminate this Agreement at any time upon giving written notice to Customer. Customer agrees to return to ADI the Evaluation Board at that time. LIMITATION OF LIABILITY. THE EVALUATION BOARD PROVIDED HEREUNDER IS PROVIDED "AS IS" AND ADI MAKES NO WARRANTIES OR REPRESENTATIONS OF ANY KIND WITH RESPECT TO IT. ADI SPECIFICALLY DISCLAIMS ANY REPRESENTATIONS, ENDORSEMENTS, GUARANTEES, OR WARRANTIES, EXPRESS OR IMPLIED, RELATED TO THE EVALUATION BOARD INCLUDING, BUT NOT LIMITED TO, THE IMPLIED WARRANTY OF MERCHANTABILITY, TITLE, FITNESS FOR A PARTICULAR PURPOSE OR NON-INFRINGEMENT OF INTELLECTUAL PROPERTY RIGHTS. IN NO EVENT WILL ADI AND ITS LICENSORS BE LIABLE FOR ANY INCIDENTAL, SPECIAL, INDIRECT, OR CONSEQUENTIAL DAMAGES RESULTING FROM CUSTOMER'S POSSESSION OR USE OF THE EVALUATION BOARD, INCLUDING BUT NOT LIMITED TO LOST PROFITS, DELAY COSTS, LABOR COSTS OR LOSS OF GOODWILL. ADI'S TOTAL LIABILITY FROM ANY AND ALL CAUSES SHALL BE LIMITED TO THE AMOUNT OF ONE HUNDRED US DOLLARS (\$100.00). EXPORT. Customer agrees that it will not directly or indirectly export the Evaluation Board to another country, and that it will comply with all applicable United States federal laws and regulations relating to exports. GOVERNING LAW. This Agreement shall be governed by and construed in accordance with the substantive laws of the Commonwealth of Massachusetts (excluding conflict of law rules). Any legal action regarding this Agreement will be heard in the state or federal courts having jurisdiction in Suffolk County, Massachusetts, and Customer hereby submits to the personal jurisdiction and venue of such courts. The United Nations Convention on Contracts for the International Sale of Goods shall not apply to this Agreement and is expressly disclaimed.

