

ADSP-2137x SHARC[®] Processor Hardware Reference

*Includes ADSP-21367, ADSP-21368,
ADSP-21369, ADSP-21371, ADSP-21375*

Revision 2.2, April 2013

Part Number
82-000100-01

Analog Devices, Inc.
One Technology Way
Norwood, Mass. 02062-9106



Copyright Information

© 2013 Analog Devices, Inc., ALL RIGHTS RESERVED. This document may not be reproduced in any form without prior, express written consent from Analog Devices, Inc.

Printed in the USA.

Disclaimer

Analog Devices, Inc. reserves the right to change this product without prior notice. Information furnished by Analog Devices is believed to be accurate and reliable. However, no responsibility is assumed by Analog Devices for its use; nor for any infringement of patents or other rights of third parties which may result from its use. No license is granted by implication or otherwise under the patent rights of Analog Devices, Inc.

Trademark and Service Mark Notice

The Analog Devices logo, Blackfin, SHARC, TigerSHARC, CrossCore, VisualDSP++, and EZ-KIT Lite are registered trademarks of Analog Devices, Inc.

All other brand and product names are trademarks or service marks of their respective owners.

Contents

PREFACE

Purpose of This Manual	xlvi
Intended Audience	xlvi
Manual Contents	xlvi
What's New in This Manual	xlix
Technical Support	xlix
Supported Processors	1
Product Information	1
Analog Devices Web Site	li
EngineerZone	li
Notation Conventions	lii
Register Diagram Conventions	liii

INTRODUCTION

Design Advantages	1-1
SHARC Family Product Offerings	1-2

Contents

Processor Architectural Overview	1-3
Processor Core	1-3
I/O Peripherals	1-3
I/O Processor	1-3
Digital Audio Interface (DAI)	1-4
Interrupt Controller	1-4
Signal Routing Unit	1-4
Digital Peripheral Interface (DPI)	1-5
Interrupt Controller	1-5
Signal Routing Unit 2	1-5
Development Tools	1-6
Differences from Previous Processors	1-7
I/O Architecture Enhancements	1-7

I/O PROCESSOR

Features	2-2
Register Overview	2-3
DMA Channel Registers	2-3
DMA Channel Allocation	2-3
Standard DMA Parameter Registers	2-4
Extended DMA Parameter Registers	2-7
Data Buffers	2-8
Chain Pointer Registers	2-10

TCB Storage	2-11
Serial Port TCB	2-11
SPI TCB	2-11
UART TCB	2-12
External Port TCB	2-12
Clocking	2-17
Functional Description	2-17
Automated Data Transfer	2-17
DMA Transfer Types	2-18
DMA Direction	2-19
Internal to External Memory	2-19
Peripheral to Internal Memory	2-20
Internal Memory to Internal Memory	2-20
DMA Controller Addressing	2-20
Internal Index Register Addressing	2-22
External Index Register Addressing	2-23
DMA Channel Status	2-23
DMA Start and Stop Conditions	2-24
Operating Modes	2-25
DMA Chaining	2-27
TCB Memory Storage	2-27
Chain Assignment	2-28
Starting Chain Loading	2-30

Contents

TCB Chain Loading Priority	2-31
Chain Insert Mode (SPORTs Only)	2-31
Fixed DMA Channel Arbitration	2-31
Peripheral DMA Bus	2-36
External Port DMA Bus	2-37
Rotating DMA Channel Arbitration	2-37
Rotating Priority by Group	2-38
Interrupts	2-38
Sources	2-39
Unchained DMA Interrupts	2-39
Chained DMA Interrupts	2-39
Transfer Completion Types	2-40
Internal Transfer Completion	2-40
Access Completion	2-41
Core Single Word Transfer Interrupts	2-41
Interrupt Versus Channel Priorities	2-41
Debug Features	2-42
Emulation Considerations	2-43
Effect Latency	2-43
Write Effect Latency	2-43
IOP Effect Latency	2-43
IOP Throughput	2-43
Programming Model	2-44
General Procedure for Configuring DMA	2-44

EXTERNAL PORT

Features	3-2
Pin Descriptions	3-4
Pin Multiplexing	3-4
Register Overview	3-4
Clocking	3-5
Functional Description	3-6
External Port Arbitration	3-7
External Port Bus Arbitration Conflicts	3-8
Channel Freezing	3-8
Asynchronous Memory Interface	3-8
AMI Features	3-9
Functional Description	3-9
Asynchronous Reads	3-10
Asynchronous Writes	3-11
Parameter Timing	3-12
Idle Cycles	3-12
Address Mapping	3-12
Operating Modes	3-13
Data Packing	3-13
External Access Extension	3-14
Predictive Reads	3-15

Contents

SDRAM Controller	3-16
Features	3-16
Functional Description	3-17
SDRAM Commands	3-18
Load Mode Register	3-19
Single Bank Activation	3-20
Multibank Activation (ADSP-2137x Processors)	3-21
Single Precharge (ADSP-2137x Processors)	3-21
Precharge All	3-21
Read/Write	3-21
Read/Write Full Page Burst (ADSP-2137x Processors) ...	3-24
Burst Stop (ADSP-2137x Processors)	3-24
Auto-Refresh	3-25
No Operation/Command Inhibit	3-25
Command Truth Table	3-25
Address Mapping	3-26
External Addressing Modes	3-27
Refresh Rate Control	3-32
Internal SDRAM Bank Access	3-34
Single Bank Access	3-34
Multibank Access (ADSP-2137x Processors)	3-34
Multi Bank Operation with Data Packing (ADSP-2137x)	3-36
Timing Parameters	3-36
Fixed Timing Parameters	3-37

Data Mask (DQM)	3-37
Resetting the Controller	3-37
Operating Modes	3-38
Parallel Connection of SDRAMs	3-38
Buffering Controller for Multiple SDRAMs	3-39
SDRAM Read Optimization	3-41
Core Accesses	3-42
DMA Access	3-43
Notes on Read Optimization	3-43
Self-Refresh Mode	3-44
Forcing SDRAM Commands	3-45
Force Precharge All	3-45
Force Load Mode Register (ADSP-2137x Only)	3-46
Force Auto-Refresh	3-46
Shared Memory Interface (ADSP-21368)	3-46
Pin Descriptions	3-48
Functional Description	3-48
Bus Arbitration Protocol	3-48
Bus Synchronization After Reset	3-53
Shared AMI Protocol	3-55
Shared SDRAM Protocol	3-55
Operating Modes	3-56
Rotating Priority Bus Arbitration (RPBA)	3-56
Bus Mastership Time-Out	3-57

Contents

Data Transfer	3-58
Data Buffers	3-59
Receive Buffer	3-59
Transmit Buffer	3-59
Core Access	3-60
External Port Dual Data Fetch	3-60
Conditional Instructions	3-60
External Instruction Fetch (ADSP-2137x)	3-61
Fetching Instructions From External Memory	3-61
External Port DMA Transfers	3-70
External Port DMA Parameter Registers	3-71
Operating Modes	3-73
Internal DMA Addressing	3-73
Standard DMA	3-73
Circular Buffered DMA	3-74
Chained DMA Mode	3-75
Changing DMA Direction on the Fly (ADSP-2137x)	3-75
Scatter/Gather DMA (ADSP-2137x)	3-76
External Address Calculation	3-77
Delay Line DMA	3-81
External Address Calculation for Reads	3-83

Interrupts	3-85
Access Completion (ADSP-2137x)	3-85
Internal Transfer Completion	3-86
Interrupt Dependency on DMA Mode	3-86
External Port Throughput	3-87
AMI Data Throughput	3-87
SDRAM Throughput	3-87
Throughput Conditional Instructions	3-88
External Instruction Fetch Throughput (ADSP-2137x)	3-88
Effect Latency	3-90
Shared Memory	3-90
Write Effect Latency	3-90
Programming Models	3-90
External Port	3-91
AMI Initialization	3-91
DMA	3-91
Standard DMA (ADSP-21367/8/9)	3-92
Chained DMA (ADSP-21367/8/9)	3-93
Standard DMA (ADSP-21371/5)	3-94
Chained DMA (ADSP-21371/5)	3-95
Delay Line DMA	3-96
Disabling and Re-enabling DMA	3-96
Additional Information	3-97

Contents

SDRAM Controller	3-98
Power-Up Sequence	3-98
Output Clock Generator Programming Model	3-99
Self-Refresh Mode	3-100
Changing the VCO Clock During Runtime	3-100
Bus Synchronization with Shared SDRAM	3-101
Bus Synchronization Notes	3-103
Conditional Bus Master Instruction	3-104
External Instruction Fetch	3-104
AMI Configuration	3-104
SDRAM Configuration	3-104
External Memory Access Restrictions	3-105
ADSP-21367/8/9 Only	3-105
ADSP-2137x Only	3-106

MEMORY-TO-MEMORY PORT DMA

Features	4-2
Register Overview	4-2
Clocking	4-2
Functional Description	4-3
Data Transfer	4-3
Data Buffer	4-3
DMA Transfer	4-4
Interrupts	4-4
MTM Throughput	4-5

Effect Latency	4-5
Write Effect Latency	4-5
MTM Effect Latency	4-5
Programming Model	4-5

PULSE WIDTH MODULATION

Features	5-2
Pin Descriptions	5-4
Multiplexing Scheme	5-4
Register Overview	5-5
Clocking	5-6
Functional Description	5-6
Two-Phase PWM Generator	5-6
Switching Frequencies	5-6
Duty Cycles	5-7
Dead Time	5-12
Output Control Unit	5-12
Output Enable	5-13
Output Polarity	5-13
Complementary Outputs	5-13
Crossover	5-13
Emergency Dead Time for Over Modulation	5-14
Output Control Feature Precedence	5-16

Contents

Operating Modes	5-17
Waveform Modes	5-17
Edge-Aligned Mode	5-17
Center-Aligned Mode	5-18
PWM Timer Edge Aligned Update	5-20
Single Update Mode	5-21
Double Update Mode	5-22
Effective Accuracy	5-23
Synchronization of PWM Groups	5-24
Interrupts	5-24
Debug Features	5-26
Status Debug Register	5-26
Emulation Considerations	5-26
Effect Latency	5-27
Write Effect Latency	5-27
PWM Effect Latency	5-27
DIGITAL APPLICATION/DIGITAL PERIPHERAL INTERFACES	
Features	6-2
Register Overview	6-3
Clocking	6-4
Functional Description	6-4
DAI/DPI Signal Naming Conventions	6-7
I/O Pin Buffers	6-7

Pin Buffers as Signal Output	6-8
Pin Buffers as Signal Input	6-10
Pin Buffers as Open Drain	6-11
Programmable Pull-Up Resistors	6-11
DAI/DPI Pin Buffer Status	6-12
Unused DAI/DPI Pins	6-12
Miscellaneous Buffers	6-12
DAI/DPI Peripherals	6-14
Output Signals With Pin Buffer Enable Control	6-14
Output Signals Without Pin Buffer Enable Control	6-16
Signal Routing Units (SRUs)	6-16
Signal Routing Matrix by Groups	6-16
DAI/DPI Group Routing	6-18
Rules for SRU Connections	6-20
Making SRU Connections	6-20
DAI Routing Capabilities	6-24
DPI Routing Capabilities	6-25
Pin Buffer Input	6-26
Pin Buffer Enable	6-26
Miscellaneous Signals	6-27
DAI Default Routing	6-28
DPI Default Routing	6-31
Interrupts	6-32
System versus Exception Interrupts	6-32

Contents

Functional Description	6-33
DAI Interrupt Channels	6-33
DAI Interrupt Priorities	6-34
DPI Interrupt Channels	6-34
DPI Interrupt Priorities	6-34
DAI Miscellaneous Interrupts	6-35
DPI Miscellaneous Interrupts	6-35
DAI/DPI Interrupt Mask Events	6-36
DAI Interrupt Acknowledge	6-38
DPI Interrupt Acknowledge	6-39
Core Versus DAI/DPI Interrupts	6-39
Debug Features	6-40
DAI Shadow Registers	6-40
DPI Shadow Registers	6-40
Loop Back Routing	6-40
Effect Latency	6-42
Write Effect Latency	6-42
Signal Routing Unit Effect Latency	6-42
Programming Model	6-42
DAI Example System	6-43

SERIAL PORTS

Features	7-2
Pin Descriptions	7-4

SRU Programming	7-5
SRU SPORT Receive Master	7-6
SRU SPORT Signal Integrity	7-6
Register Overview	7-7
Clocking	7-8
Master Clock	7-9
Master Frame Sync	7-9
Slave Mode	7-10
Functional Description	7-11
Architecture	7-11
Data Types and Companding	7-12
Companding the Data Stream	7-14
Transmit Path	7-15
Receive Path	7-15
Frame Sync	7-16
Frame Sync and Data Sampling	7-16
Serial Word Length	7-17
Internal Versus External Frame Syncs	7-18
External Frame Sync Sampling	7-19
Logic Level Frame Syncs	7-19
Data-Independent Frame Sync	7-20
Operating Modes	7-20
Mode Selection	7-22
Channel Order First	7-24

Contents

Standard Serial Mode	7-24
Timing Control Bits	7-24
Clocking Options	7-25
Frame Sync Options	7-25
Framed Versus Unframed Frame Syncs	7-25
Early Versus Late Frame Syncs	7-26
Left-Justified Mode	7-28
Master Serial Clock and Frame Sync Rates	7-28
Timing Control Bits	7-29
I ² S Mode	7-29
Master Serial Clock and Frame Sync Rates	7-29
I ² S Compatibility	7-30
Timing Control Bits	7-30
Multichannel Mode	7-31
Clocking Options	7-31
Frame Sync Options	7-32
Frame Sync Delay (MFD)	7-32
Transmit Data Valid Signal	7-33
Transmit Data Valid Output	7-34
Timing Control Bits	7-35
Number of Channels (NCH)	7-35

Packed Mode	7-36
Clocking Options	7-37
Frame Sync Options	7-37
Timing Control Bits	7-37
Active Channel Selection Registers	7-38
Transmit Selection Registers	7-38
Receive Selection Registers	7-39
Companding Selection	7-39
Companding Limitations	7-39
Data Transfer Types	7-40
Data Buffers	7-40
Transmit Buffers (TXSPxA/B)	7-41
Receive Buffers (RXSPxA/B)	7-41
Buffer Status	7-41
Data Buffer Packing	7-43
Core Transfers	7-43
Single Word Transfers	7-43
Frame Sync Generation	7-44
Internal Memory DMA Transfers	7-45
Standard DMA	7-46
DMA Chaining	7-47
DMA Chain Insertion Mode	7-48
Frame Sync Generation	7-49

Contents

Interrupts	7-49
Internal Transfer Completion	7-50
Shared Channels	7-51
Error Detection	7-51
Error Status	7-53
Debug Features	7-54
SPORT Loopback	7-54
LoopBack Routing	7-54
Buffer Hang Disable (BHD)	7-54
Effect Latency	7-55
Write Effect Latency	7-55
SPORT Effect Latency	7-55
Programming Model	7-55
Setting Up and Starting DMA Master Mode	7-56
Setting Up and Starting Chained DMA	7-56
Enter DMA Chain Insertion Mode	7-57
Setting Up and Starting Multichannel Mode	7-57
Multichannel Mode Backward Compatibility	7-58
Programming Packed Mode	7-59
Additional Information for External Frame Sync Operation	7-60
Companding As a Function	7-60

INPUT DATA PORT

Features	8-2
----------------	-----

Pin Descriptions	8-3
SRU Programming	8-4
Register Overview	8-5
Clocking	8-6
Functional Description	8-6
Operating Modes	8-7
PDAP Port Selection	8-9
Data Hold	8-9
PDAP Data Masking	8-10
PDAP Data Packing	8-10
No Packing	8-10
Packing by 2	8-11
Packing by 3	8-12
Packing by 4	8-13
Data Transfer	8-14
Data Buffer	8-14
Core Transfers	8-15
SIP Data Buffer Format	8-16
PDAP Data Buffer Format	8-18
DMA Transfers	8-19
Data Buffer Format for DMA	8-19
DMA Channel Priority	8-20
Standard DMA	8-20
Ping-Pong DMA	8-21

Contents

Multichannel DMA Operation	8-21
Multichannel FIFO Status	8-22
Interrupts	8-23
Interrupt Acknowledge	8-23
Threshold Interrupts	8-23
DMA Interrupts	8-24
FIFO Overflow Interrupts	8-24
Debug Features	8-25
Status Register Debug	8-25
Buffer Hang Disable	8-25
Shadow Registers	8-25
Core FIFO Write	8-26
Effect Latency	8-26
Write Effect Latency	8-26
IDP Effect Latency	8-26
Programming Model	8-27
Setting Miscellaneous Bits	8-27
Starting Core Interrupt-Driven Transfer	8-27
Additional Notes	8-28
Starting A Standard DMA Transfer	8-29
Starting a Ping-Pong DMA Transfer	8-30
Servicing Interrupts for DMA	8-31

ASYNCHRONOUS SAMPLE RATE CONVERTER

Features	9-2
----------------	-----

Pin Descriptions	9-3
SRU Programming	9-3
Register Overview	9-4
Clocking	9-5
Functional Description	9-5
Operating Modes	9-9
TDM Daisy Chain Mode	9-11
TDM Input Daisy Chain	9-11
TDM Output Daisy Chain	9-12
Bypass Mode	9-12
Matched-Phase Mode	9-12
Data Format Matched-Phase Mode	9-14
Group Delay	9-14
Decimation Rate	9-15
Muting Modes	9-15
Soft Mute	9-15
Hard Mute	9-16
Auto Mute	9-16
Interrupts	9-16
Debug Features	9-17
Effect Latency	9-17
Write Effect Latency	9-17
SRC Effect Latency	9-18

Contents

SONY/PHILIPS DIGITAL INTERFACE

Features	10-2
Pin Descriptions	10-3
SRU Programming	10-5
Register Overview	10-6
Clocking	10-7
S/PDIF Transmitter	10-7
Functional Description	10-7
Input Data Format	10-10
Operating Modes	10-12
Full Serial Mode	10-12
Standalone Mode	10-12
Data Output Mode	10-13
S/PDIF Receiver	10-14
Functional Description	10-14
Clock Recovery	10-16
Output Data Format	10-16
Channel Status	10-17
Operating Modes	10-17
Compressed or Non-linear Audio Data	10-17
Emphasized Audio Data	10-18
Single-Channel Double-Frequency Mode	10-19

Clock Recovery Modes	10-19
Digital On-Chip PLL	10-19
External Analog PLL	10-20
Interrupts	10-20
Transmitter Interrupt	10-20
Receiver Interrupts	10-21
Receiver Error Interrupts	10-21
Debug Features	10-22
Loop Back Routing	10-22
Effect Latency	10-22
Write Effect Latency	10-22
S/PDIF Effect Latency	10-22
S/PDIF Transmit	10-22
S/PDIF Receive	10-23
Programming Model	10-23
Programming the Transmitter	10-24
Programming the Receiver	10-24
Interrupted Data Streams on the Receiver	10-25

PRECISION CLOCK GENERATOR

Features	11-2
Pin Descriptions	11-3
SRU Programming	11-4
Register Overview	11-5
Clocking	11-5

Contents

Functional Description	11-6
Serial Clock	11-6
Frame Sync	11-7
Frame Sync Output	11-7
Divider Mode Selection	11-8
Phase Shift	11-8
Pulse Width	11-9
Default Pulse Width	11-10
Timing Example for I2S Mode	11-10
Operating Modes	11-11
Normal Mode	11-11
Bypass Mode	11-12
One-Shot Mode	11-13
External Event Trigger	11-14
External Event Trigger Delay	11-15
Audio System Example	11-15
Clock Configuration Examples	11-17
Effect Latency	11-18
Write Effect Latency	11-18
PCG Effect Latency	11-19
Programming Model	11-19
Frame Sync Phase Setting	11-20
External Event Trigger	11-20
Debug Features	11-21

SERIAL PERIPHERAL INTERFACE PORTS

Features	12-2
Pin Descriptions	12-3
SRU Programming	12-4
Register Overview	12-6
Clocking	12-6
Choosing the Pin Enable for the SPI Clock	12-7
Functional Description	12-8
Single Master Systems	12-10
Multi Master Systems	12-11
Operating Modes	12-13
Transfer Initiate Mode	12-13
SPI Modes	12-14
Slave Select Outputs	12-16
Frame Delay for Slave	12-17
Data Transfer	12-18
Data Buffer	12-18
Core Transfers	12-19
DMA Transfers	12-20
Slave DMA Transfer Preparation	12-21
SPI DMA Chaining	12-22
Setting Up and Starting Chained DMA	12-22

Contents

Core and DMA Transfers	12-23
Changing SPI Configuration	12-23
Starting and Stopping SPI Data Transfers	12-24
Interrupts	12-25
Interrupt Sources	12-26
Internal Transfer Completion	12-27
Multi Master Error	12-27
Debug Features	12-28
Shadow Receive Buffers	12-29
Internal Loopback Mode	12-29
Loop Back Routing	12-29
Effect Latency	12-30
Write Effect Latency	12-30
SPI Effect Latency	12-30
Programming Model	12-30
Master Mode Core Transfers	12-30
Multimaster Transfers	12-32
Slave Mode Core Transfers	12-32
Master Mode DMA Transfers	12-34
Slave Mode DMA Transfers	12-35
Chained DMA Transfers	12-37
Stopping Core Transfers	12-37
Stopping DMA Transfers	12-38
Switching from Transmit To Transmit/Receive DMA	12-39

Switching from Receive to Receive/Transmit DMA	12-40
DMA Error Interrupts	12-42

PERIPHERAL TIMERS

Features	13-2
Pin Descriptions	13-3
SRU Programming	13-3
Register Overview	13-4
Read-Modify-Write	13-5
Clocking	13-5
Functional Description	13-6
Operating Modes	13-7
Pulse Width Modulation Mode (PWM_OUT)	13-8
PWM Waveform Generation	13-10
Single-Pulse Generation	13-12
Pulse Mode	13-12
Pulse Width Count and Capture Mode (WDTH_CAP)	13-13
External Event Watchdog Mode (EXT_CLK)	13-15
Interrupts	13-17
Sources	13-18
Watchdog Functionality	13-19
Debug Features	13-19
Loop Back Routing	13-19
Emulation Considerations	13-19

Contents

Effect Latency	13-20
Write Effect Latency	13-20
Peripheral Timers Effect Latency	13-20
Programming Model	13-20
PWM Out Mode	13-21
WDTH_CAP Mode	13-23
EXT_CLK Mode	13-24

UART PORT CONTROLLER

Features	14-2
SRU Programming	14-3
Register Overview	14-3
Clocking	14-4
Functional Description	14-6
Serial Communication	14-7
Operating Modes	14-8
Data Packing	14-8
9-Bit Transmission Mode	14-9
Packed Mode	14-10
Data Transfer	14-10
Data Buffers	14-11
Transmit Holding Registers (UARTxTHR)	14-11
Receive Buffer Registers (UARTxRBR)	14-12
Core Transfers	14-13

DMA Transfers	14-14
DMA Chaining	14-15
Interrupts	14-15
Interrupt Routing	14-16
DPI	14-16
UART	14-17
DMA Interrupts	14-17
Core Interrupts	14-18
Error Interrupts	14-20
Debug Features	14-21
Shadow Registers	14-21
Shadow Buffer	14-21
Loop Back Routing	14-21
Effect Latency	14-21
Write Effect Latency	14-22
UART Effect Latency	14-22
Programming Model	14-22
Autobaud Detection	14-22
Programming Model for DMA Transfers	14-23
Setting Up and Starting Chained DMA	14-24
Notes on Using UART DMA	14-24
Programming Model for Core Transfers	14-25

TWO-WIRE INTERFACE CONTROLLER

Features	15-2
----------------	------

Contents

Pin Descriptions	15-3
SRU Programming	15-4
Clocking	15-4
Register Overview	15-5
Functional Description	15-6
Bus Arbitration	15-9
Start and Stop Conditions	15-10
Slave Mode Addressing	15-11
Master Mode Addressing	15-11
Data Transfer	15-11
Data Buffers	15-11
8-Bit Transmit FIFO Register	15-12
16-Bit Transmit FIFO Register	15-12
8-Bit Receive FIFO Register	15-13
16-Bit Receive FIFO Register	15-13
Operating Modes	15-14
General Call Addressing	15-14
Fast Mode	15-15
Interrupts	15-15
Interrupt Routing	15-16
DPI	15-16
TWI	15-16
Interrupt Sources	15-17

Debug Features	15-18
Buffer Hang Disable	15-18
Loop Back Routing	15-18
Effect Latency	15-18
Write Effect Latency	15-19
TWI Effect Latency	15-19
Programming Model	15-19
General Setup	15-19
Slave Mode	15-20
Master Mode Clock Setup	15-21
Master Mode Transmit	15-22
Master Mode Receive	15-23
Repeated Start Condition	15-24
Transmit/Receive Repeated Start Sequence	15-25
Receive/Transmit Repeated Start Sequence	15-26
Electrical Specifications	15-27
 POWER MANAGEMENT	
Features	16-1
Register Overview	16-1
Phase-Locked Loop (PLL)	16-2
Functional Description	16-2
PLL Input Clock	16-3
Pre Divider Input	16-3

Contents

PLL Multiplier	16-4
PLL Hardware Control	16-4
PLL Software Control	16-4
PLL VCO	16-5
Output Clock Generator	16-6
Core Clock (CCLK)	16-6
IOP Clock (PCLK)	16-6
SDRAM Clock (SDCLK)	16-6
Default PLL Hardware Settings	16-7
Operating Modes	16-7
Bypass Mode	16-7
Normal Mode	16-8
Clocking Golden Rules	16-8
Power-Up Sequence	16-8
PLL Start-Up	16-9
Power Management	16-10
Peripherals	16-10
DAI Routing Unit	16-10
External Port Control	16-11
Example for Clock Management	16-11
General Notes on Power Savings	16-12

Programming Model	16-12
Post Divider	16-13
Multiplier and Post Divider Programming Model	16-13
Back to Back Bypass	16-15

SYSTEM DESIGN

Features	17-2
Pin Descriptions	17-2
Register Overview	17-2
Processor Reset	17-3
Hardware Reset	17-4
Software Reset	17-4
Running Reset (ADSP-2137x Only)	17-5
System Considerations	17-6
External Host	17-7
Processor Booting	17-7
Boot Mechanisms	17-8
External Port Booting	17-8
SPI Port Booting	17-12
Master Boot Mode	17-13
Master Header Information	17-14
Slave Boot Mode	17-16

Contents

SPI Boot Packing	17-17
32-Bit SPI Packing	17-19
16-Bit SPI Packing	17-20
8-Bit SPI Packing	17-21
Kernel Boot Time	17-22
ROM Booting	17-23
Programming Model	17-23
Running Reset	17-24
Running The Boot Kernel	17-24
Loading the Boot Kernel Using DMA	17-24
Executing the Boot Kernel	17-25
Loading the Application	17-25
Loading the Application's Interrupt Vector Table	17-25
Starting Program Execution	17-26
Memory Aliasing in Internal Memory	17-26
Pin Multiplexing	17-27
Core FLAG Pins Multiplexing	17-27
Backward Compatibility	17-28
External Port Pin Multiplexing	17-28
Multiplexed External Port Pins	17-29
Backward Compatibility	17-30
Parallel Connection of External Port and DPI Flag Pins	17-30
External Port Multiplexing Examples	17-32

High Frequency Design	17-33
Circuit Board Design	17-33
Clock Input Specifications and Jitter	17-33
RESETOUT	17-34
Input Pin Hysteresis	17-34
Pull-Up/Pull-Down Resistors	17-35
Memory Select Pins	17-35
Edge Triggered I/O	17-36
Asynchronous Inputs	17-36
Decoupling and Grounding	17-37
Circuit Board Layout	17-37
Other Recommendations and Suggestions	17-37
EZ-KIT Lite Schematics	17-39
Oscilloscope Probes	17-39
Recommended Reading	17-40
System Components	17-41
Supervisory Circuits	17-41
Definition of Terms	17-43

REGISTERS REFERENCE

Overview	A-2
Register Diagram Conventions	A-2
Bit Types and Settings	A-3

Contents

System and Power Management Registers	A-4
System Control Register (SYSCTL)	A-4
Power Management Control Registers (PMCTL)	A-7
Running Reset Control Register (RUNRSTCTL)	A-11
Peripheral Registers	A-11
External Port Registers	A-11
Control Register (EPCTL)	A-12
ADSP-21367/8/9 External Port DMA Control Registers (DMACx)	A-15
ADSP-2137x External Port DMA Control Registers (DMACx)	A-17
AMI Control Registers (AMICTLx)	A-21
AMI Status Register (AMISTAT)	A-24
SDRAM Registers	A-25
Control Register (SDCTL)	A-25
Control Status Register (SDSTAT)	A-29
Refresh Rate Control Register (SDRRC)	A-30
Shared Memory Status Register (SYSTAT, ADSP-21368 Only)	A-31
Memory-to-Memory Registers	A-32
DMA Control (MTMCTL Register)	A-32
Pulse Width Modulation Registers	A-33
Global Control Register (PWMGCTL)	A-33
Global Status Register (PWMGSTAT)	A-35
Control Register (PWMCTLx)	A-35
Status Registers (PWMSTATx)	A-37

Output Disable Registers (PWMSEGx)	A-37
Polarity Select Registers (PWMPOLx)	A-38
Period Registers (PWMPERIODx)	A-39
Duty Cycle High Side Registers (PWMAx, PWMBx)	A-39
Duty Cycle Low Side Registers (PWMALx, PWMBLx)	A-40
Dead Time Registers (PWMDTx)	A-40
Debug Status Registers (PWMDBGx)	A-40
DAI Signal Routing Unit Registers	A-40
Clock Routing Control Registers (SRU_CLKx, Group A)	A-41
Serial Data Routing Registers (SRU_DATx, Group B)	A-46
Frame Sync Routing Control Registers (SRU_FSx, Group C)	A-51
Pin Signal Assignment Registers (SRU_PINx, Group D)	A-55
Miscellaneous Signal Routing Registers (SRU_MISCx, Group E)	A-61
Pin Buffer Enable Registers (SRU_PBENx, Group F)	A-64
Pin Buffer Registers	A-68
Pin Buffer Status Registers (DAI_PIN_STAT)	A-68
Resistor Pull-up Enable Register (DAI_PIN_PULLUP)	A-68
Interrupt Controller Registers	A-69
Peripherals Routed Through the DAI	A-70
Serial Port Registers	A-70
Divisor Registers (DIVx)	A-70

Contents

Serial Control Registers (SPCTLx)	A-71
Multichannel Control Registers (SPMCTLx)	A-87
Multichannel Active Channel Select Registers	A-91
Transmit Channel Select Registers (MTxCSy)	A-92
Transmit Channel Compand Select Registers (MTxCCSy)	A-92
Receive Channel Select Registers (MRxCSy)	A-92
Receive Compand Channel Select Registers (MRxCCSy)	A-93
Error Control Register (SPERRCTLx)	A-93
Error Status Register (SPERRSTAT)	A-95
Input Data Port Registers	A-95
Serial Input Port Control Register 0 (IDP_CTL0)	A-95
Serial Input Port Control Register 1 (IDP_CTL1)	A-98
Parallel Data Acquisition Port Control Register (IDP_PP_CTL)	A-99
Status Register (DAI_STAT0)	A-101
Status Debug Register 1 (DAI_STAT1)	A-103
Sample Rate Converter Registers	A-104
Control Registers (SRCCTLx)	A-104
Mute Register (SRCMUTE)	A-108
Ratio Registers (SRCRATx)	A-109
Precision Clock Generator Registers	A-111
Control Registers (PCG_CTLxy)	A-111
Pulse Width Registers (PCG_PWx)	A-113
Frame Synchronization Registers (PCG_SYNCx)	A-115

Sony/Philips Digital Interface Registers	A-119
Transmitter Registers	A-119
Transmit Control Register (DITCTL)	A-119
Transmit Status Bit Registers for Subframe A/B (DITCHANAx/Bx)	A-121
Transmit User Bits Buffer Registers for Subframe A/B Registers (DITUSRBITAx/Bx)	A-122
User Bit Update Register (DITUSRUPD)	A-123
Receiver Registers	A-124
Receive Control Register (DIRCTL)	A-124
Receive Status Register (DIRSTAT)	A-126
Receive Status Registers for Subframe A (DIRCHANL)	A-129
Receive Status Registers for Subframe B (DIRCHANR)	A-129
DPI Signal Routing Unit Registers	A-129
Miscellaneous Signal Routing Registers (SRU2_INPUTx, Group A)	A-130
Pin Assignment Signal Routing (SRU2_PINx, Group B)	A-134
Pin Enable Signal Routing (SRU2_PBENx, Group C)	A-138
Pin Buffer Registers	A-141
Pin Buffer Status Register (DPI_PIN_STAT)	A-142
Resistor Pull-up Enable Register (DPI_PIN_PULLUP) ...	A-142
Interrupt Controller Registers	A-143

Peripherals Routed Through the DPI	A-144
Serial Peripheral Interface Registers	A-144
Control Registers (SPICTL, SPICTLB)	A-144
DMA Configuration Registers (SPIDMAC, SPIDMACB)	A-151
Baud Rate Registers (SPIBAUD, SPIBAUDB)	A-153
Status Registers (SPISTAT, SPISTATB)	A-153
Flags Registers (SPIFLG, SPIFLGB)	A-155
UART Control and Status Registers	A-157
Line Control Register (UARTxLCR)	A-157
Line Status Registers (UARTxLSR, UARTxLSRSH)	A-159
Interrupt Enable Register (UARTxIER)	A-160
Interrupt Identification Registers (UARTxIIR, UARTxIIRSH) ..	A-161
Divisor Latch Registers (UARTxDLL, UARTxDLH)	A-163
Scratch Register (UARTxSCR)	A-163
Mode Register (UARTxMODE)	A-163
Buffer Control Registers (UARTxTXCTL, UARTxRXCTL)	A-165
DMA Status Registers (UARTxTXSTAT, UARTxRXSTAT)	A-166
Two-Wire Interface Registers	A-167
Master Internal Time Register (TWIMITR)	A-167
Clock Divider Register (TWIDIV)	A-168
Slave Mode Control Register (TWISCTL)	A-168
Slave Address Register (TWISADDR)	A-170
Slave Status Register (TWISSTAT)	A-170
Master Control Register (TWIMCTL)	A-170

Master Address Register (TWIMADDR)	A-173
Master Mode Status Register (TWIMSTAT)	A-173
FIFO Control Register (TWIFIFOCTL)	A-176
FIFO Status Register (TWIFIFOSTAT)	A-177
Interrupt Latch Register (TWIIRPTL)	A-179
Interrupt Mask Register (TWIIMASK)	A-180
Peripheral Timer Registers	A-182
Read-Modify-Write Timer Control Register	A-182
Control Registers (TMxCTL)	A-183
Status Registers (TMxSTAT)	A-184
Register Listing	A-186

PERIPHERAL INTERRUPT CONTROL

Interrupt Latency	B-1
Interrupt Acknowledge	B-2
Interrupt Completion	B-3
Interrupt Priority	B-4
Peripherals with Multiple Interrupt Vector Addresses	B-6
Priority Interrupt Control Registers (PICRx)	B-7

AUDIO FRAME FORMATS

Overview	C-2
Standard Serial Mode	C-2
I ² S Mode	C-3
Left-Justified Mode	C-5

Right-Justified Mode	C-5
TDM Mode	C-6
Packed TDM Mode	C-7
MOST Mode	C-8
AES/EBU/SPDIF Formats	C-9
Subframe Format	C-12
Channel Coding	C-14
Preambles	C-15

PREFACE

Thank you for purchasing and developing systems using ADSP-21367/8/9 and ADSP-21371/75 SHARC® processors from Analog Devices, Inc.

Purpose of This Manual

ADSP-2137x SHARC Processor Hardware Reference contains information about the peripheral set and I/O properties for the ADSP-21367/8/9 and ADSP-2137x processors. These are 32-bit, fixed- and floating-point digital signal processors from Analog Devices for use in computing, communications, and consumer applications.

The manual provides information on the processor's I/O architecture and the operation of the peripherals associated with each model.

Intended Audience

The primary audience for this manual is a programmer who is familiar with Analog Devices processors. The manual assumes the audience has a working knowledge of the appropriate processor architecture and instruction set. Programmers who are unfamiliar with Analog Devices processors can use this manual, but should supplement it with other texts, such as hardware and programming reference manuals that describe their target architecture.

Manual Contents

This manual consists of:

- Chapter 1, “[Introduction](#)”
Provides an architectural overview of the ADSP-21367/8/9 and ADSP-2137/75 SHARC processors.
- Chapter 2, “[I/O Processor](#)”
Describes the input/output processor architecture, and provides direct memory access (DMA) procedures for the processor peripherals.
- Chapter 3, “[External Port](#)”
Describes how the processor’s on-chip DMA controller acts as a machine for transferring data without core interruption.
- Chapter 4, “[Memory-to-Memory Port DMA](#)”
The memory-to-memory port DMA module is used for internal memory transfers only.
- Chapter 5, “[Pulse Width Modulation](#)”
Describes the implementation and use of the pulse width modulation module which provides a technique for controlling analog circuits with the microprocessor’s digital outputs.
- Chapter 6, “[Digital Application/Digital Peripheral Interfaces](#)”
Provides information about the digital audio interface (DAI) which allows you to attach an arbitrary number and variety of peripherals to the processor while retaining high levels of compatibility.
- Chapter 7, “[Serial Ports](#)”
Describes the up to eight dual data line serial ports. Each SPORT contains a clock, a frame sync, and two data lines that can be configured as either a receiver or transmitter pair.

- Chapter 8, “[Input Data Port](#)”
Discusses the function of the input data port (IDP) which provides a low overhead method of routing signal routing unit (SRU) signals back to the core’s memory.
- Chapter 9, “[Asynchronous Sample Rate Converter](#)”
Provides information on the sample rate converter (SRC) module. This module performs synchronous or asynchronous sample rate conversion across independent stereo channels, without using any internal processor resources.
- Chapter 10, “[Sony/Philips Digital Interface](#)”
Provides information on the use of the Sony/Philips Digital Interface which is a standard audio file transfer format that allows the transfer of digital audio signals from one device to another without having to be converted to an analog signal.
- Chapter 11, “[Precision Clock Generator](#)”
Details the precision clock generators (PCG), each of which generates a pair of signals derived from a clock input signal.
- Chapter 12, “[Serial Peripheral Interface Ports](#)”
Describes the operation of the serial peripheral interface (SPI) port. SPI devices communicate using a master-slave relationship and can achieve high data transfer rate because they can operate in full-duplex mode.
- Chapter 13, “[Peripheral Timers](#)”
In addition to the internal core timer, the processors contain identical 32-bit peripheral timers that can be used to interface with external devices.
- Chapter 14, “[UART Port Controller](#)”
Describes the operation of the Universal Asynchronous Receiver/Transmitter (UART) which is a full-duplex peripheral compatible with PC-style industry-standard UART.

Manual Contents

- Chapter 15, “[Two-Wire Interface Controller](#)”
The two-wire interface is fully compatible with the widely used I²C bus standard. It is designed with a high level of functionality and is compatible with multimaster, multislave bus configurations.
- Chapter 16, “[Power Management](#)”
Contains information on managing the clock, PLL and the peripherals in order to maximize system efficiency with minimum power consumption.
- Chapter 17, “[System Design](#)”
Describes system design features of the SHARC processors. These, include resetting and booting the processor, as well as pin descriptions and other system-level information.
- Appendix A, “[Registers Reference](#)”
Provides a graphical presentation of all registers and describes the bit usage in each register.
- Appendix B “[Peripheral Interrupt Control](#)”
Provides a complete listing of the registers that are used to configure and control interrupts.
- Appendix C “[Audio Frame Formats](#)”
Provides specific information on all the serial timing protocols used for audio inter-chip communications.



This hardware reference is a companion document to the *SHARC Processor Programming Reference*. The programming reference provides information relating to the processor core, such as processing elements, internal memory, and program sequencing. It also provides programming specific information, such as complete descriptions of the ADSP-21xxx instruction set and the compute operations, including their assembly language syntax and opcode fields.

What's New in This Manual

This manual is Revision 2.2 of ADSP-2137x SHARC Processor Hardware Reference for the ADSP-21362/3/4/5/6 Processors. This revision corrects minor typographical errors and the following issues:

- TCB list for delay line DMA in [Chapter 3, “External Port”](#).
- Note on shared memory booting requirement in [Chapter 3, “External Port”](#).
- Corrected SPICLK baud rate expression in [Appendix A, “Registers Reference”](#).

Technical Support

You can reach Analog Devices processors and DSP technical support in the following ways:

- Post your questions in the processors and DSP support community at EngineerZone[®]:
<http://ez.analog.com/community/dsp>
- Submit your questions to technical support directly at:
<http://www.analog.com/support>
- E-mail your questions about processors, DSPs, and tools development software from CrossCore[®] Embedded Studio or VisualDSP++[®]:

Choose **Help > Email Support**. This creates an e-mail to processor.tools.support@analog.com and automatically attaches your CrossCore Embedded Studio or VisualDSP++ version information and `license.dat` file.

Supported Processors

- E-mail your questions about processors and processor applications to:
processor.support@analog.com or
processor.china@analog.com (Greater China support)
- In the **USA only**, call 1-800-ANALOGD (1-800-262-5643)
- Contact your Analog Devices sales office or authorized distributor. Locate one at:
www.analog.com/adi-sales
- Send questions by mail to:
Processors and DSP Technical Support
Analog Devices, Inc.
Three Technology Way
P.O. Box 9106
Norwood, MA 02062-9106
USA

Supported Processors

The name “*SHARC*” refers to a family of high-performance, floating-point embedded processors. Refer to the CCES or VisualDSP++ online help for a complete list of supported processors.

Product Information

Product information can be obtained from the Analog Devices Web site and the CCES or VisualDSP++ online help.

Analog Devices Web Site

The Analog Devices Web site, www.analog.com, provides information about a broad range of products—analog integrated circuits, amplifiers, converters, and digital signal processors.

To access a complete technical library for each processor family, go to http://www.analog.com/processors/technical_library. The manuals selection opens a list of current manuals related to the product as well as a link to the previous revisions of the manuals. When locating your manual title, note a possible errata check mark next to the title that leads to the current correction report against the manual.

Also note, [myAnalog](#) is a free feature of the Analog Devices Web site that allows customization of a Web page to display only the latest information about products you are interested in. You can choose to receive weekly e-mail notifications containing updates to the Web pages that meet your interests, including documentation errata against all manuals. [myAnalog](#) provides access to books, application notes, data sheets, code examples, and more.

Visit [myAnalog](#) to sign up. If you are a registered user, just log on. Your user name is your e-mail address.



EngineerZone

EngineerZone is a technical support forum from Analog Devices, Inc. It allows you direct access to ADI technical support engineers. You can search FAQs and technical information to get quick answers to your embedded processing and DSP design questions.

Use EngineerZone to connect with other DSP developers who face similar design challenges. You can also use this open forum to share knowledge and collaborate with the ADI support team and your peers. Visit <http://ez.analog.com> to sign up.

Notation Conventions

Text conventions in this manual are identified and described as follows.

Example	Description
File > Close	Titles in reference sections indicate the location of an item within the IDE environment's menu system (for example, the Close command appears on the File menu).
{this that}	Alternative required items in syntax descriptions appear within curly brackets and separated by vertical bars; read the example as <i>this</i> or <i>that</i> . One or the other is required.
[this that]	Optional items in syntax descriptions appear within brackets and separated by vertical bars; read the example as an optional <i>this</i> or <i>that</i> .
[this,...]	Optional item lists in syntax descriptions appear within brackets delimited by commas and terminated with an ellipsis; read the example as an optional comma-separated list of <i>this</i> .
.SECTION	Commands, directives, keywords, and feature names are in text with letter gothic font.
<i>filename</i>	Non-keyword placeholders appear in text with italic style format.
	Note: For correct operation, ... A Note provides supplementary information on a related topic. In the online version of this book, the word Note appears instead of this symbol.
	Caution: Incorrect device operation may result if ... Caution: Device damage may result if ... A Caution identifies conditions or inappropriate usage of the product that could lead to undesirable results or product damage. In the online version of this book, the word Caution appears instead of this symbol.
	Warning: Injury to device users may result if ... A Warning identifies conditions or inappropriate usage of the product that could lead to conditions that are potentially hazardous for devices users. In the online version of this book, the word Warning appears instead of this symbol.

Register Diagram Conventions

Register diagrams use the following conventions:

- The descriptive name of the register appears at the top, followed by the short form of the name in parentheses.
 - If the register is read-only (RO), write-1-to-set (W1S), or write-1-to-clear (W1C), this information appears under the name. Read/write is the default and is not noted. Additional descriptive text may follow.
 - If any bits in the register do not follow the overall read/write convention, this is noted in the bit description after the bit name.
 - If a bit has a short name, the short name appears first in the bit description, followed by the long name in parentheses.
 - The reset value appears in binary in the individual bits and in hexadecimal to the right of the register.
 - Bits marked *x* have an unknown reset value. Consequently, the reset value of registers that contain such bits is undefined or dependent on pin values at reset.
 - Shaded bits are reserved.
-  To ensure upward compatibility with future implementations, write back the value that is read for reserved bits in a register, unless otherwise specified.

Register Diagram Conventions

The following figure shows an example of these conventions.

Timer Configuration Registers (TIMERx_CONFIG)

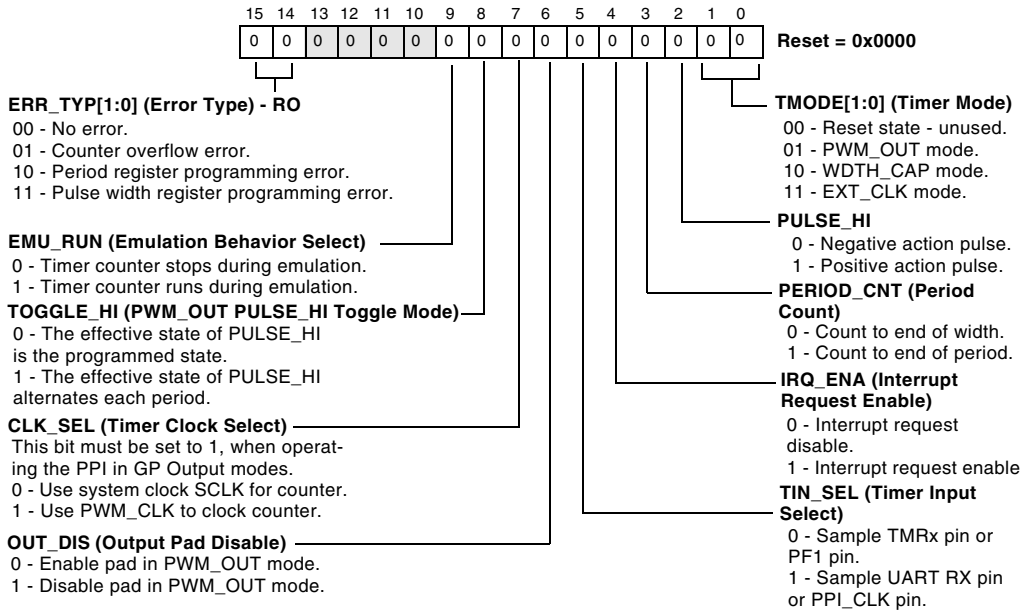

Figure 1. Register Diagram Example

1 INTRODUCTION

The ADSP-21367/8/9 and ADSP-21371/75 SHARC processors are high performance 32-bit processors used for high quality audio, medical imaging, communications, military, test equipment, 3D graphics, speech recognition, motor control, imaging, and other applications. By adding on-chip SRAM, integrated I/O peripherals, and an additional processing element for single-instruction, multiple-data (SIMD) support, this processor builds on the ADSP-21000 family DSP core to form a complete system-on-a-chip.

Design Advantages

A digital signal processor's data format determines its ability to handle signals of differing precision, dynamic range, and signal-to-noise ratios. Because floating-point DSP math reduces the need for scaling and the probability of overflow, using a floating-point processor can simplify algorithm and software development. The extent to which this is true depends on the floating-point processor's architecture. Consistency with IEEE workstation simulations and the elimination of scaling are clearly two ease-of-use advantages. High level language programmability, large address spaces, and wide dynamic range allow system development time to be spent on algorithms and signal processing concerns, rather than assembly language coding, code paging, and/or error handling. The SHARC processors are highly integrated, 32-bit floating-point processor which provides all of these design advantages.

Design Advantages

SHARC Family Product Offerings

Table 1-1 provides information on the products covered in this manual. Note that some models are available for automotive applications with controlled manufacturing. These special models may have specifications that differ from the general release models. For information on which models are available as automotive, see the product-specific data sheet.

Table 1-1. SHARC Processor Family Features

Feature	ADSP-21367 ¹	ADSP-21368	ADSP-21369	ADSP-21371	ADSP-21375
RAM	2M bit			1M bit	0.5M bit
ROM	6M bit			4M bit	2M bit
Audio Decoders in ROM ²	Yes	No			
Serial Ports	8				4
UART	2			1	
Pulse Width Modulation	Yes				No
S/PDIF	Yes		No		
Shared Memory	No	Yes	No		
SRC Performance	128 dB	140 dB	128 dB	128 dB	No SRC
Package Option ³	256-ball BGA 208-lead LQFP, exposed pad	256-ball BGA	256-ball BGA 208-lead LQFP, exposed pad	208-lead LQFP, exposed pad	
Processor Speed	400 MHz			266 MHz	

- 1 The ADSP-21367 processor includes a customer-definable ROM block. Please contact your Analog Devices sales representative for additional details.
- 2 Audio decoding algorithms include PCM, Dolby Digital EX, PCM, Dolby Digital EX, Dolby Prologic IIx, DTS 96/24, Neo:6, DTS ES, MPEG2 AAC, MPEG2 2channel, MP3, and functions like bass management, delay, speaker equalization, graphic equalization, and more. Decoder/post-processor algorithm combination support will vary depending upon the chip version and the system configurations. Please visit www.analog.com/sharc for complete information.
- 3 Analog Devices offers these packages in RoHS compliant versions.

Processor Architectural Overview

The ADSP-21367/8/9 and ADSP-2137x processors form a complete system-on-a-chip, integrating a large, high speed SRAM and I/O peripherals supported by a dedicated I/O bus. The following sections summarize the features of each functional block in the processor architecture.

Processor Core

The processor core contains two processing elements (each with three computation units and data register file), a program sequencer, two data address generators, a timer, and an instruction cache. All digital signal processing occurs in the processor core. For complete information, see *SHARC Processor Programming Reference*.

I/O Peripherals

These peripherals are coupled with the external port and therefore independent from the routing units.

- Asynchronous Memory Interface (AMI)
- SDRAM controller
- Shared Memory controller (ADSP-21368 only)
- 4 PWM modules

I/O Processor

The input/output processor (IOP) manages the off-chip data I/O to free the core from this burden. Up to thirty-four channels of DMA are available on the ADSP-21367/8/9 and ADSP-2137x processors—sixteen via the serial ports, 8 via the input data port, 4 for the UARTs, 2 for the SPI interface, 2 for the external port, and 2 for memory-to-memory transfers.

Processor Architectural Overview

The I/O processor can perform DMA transfers between the peripherals and internal memory at the full core clock speed. The architecture of the internal memory allows the IOP and the core to access internal memory simultaneously with no reduction in throughput.

Digital Audio Interface (DAI)

The digital audio interface (DAI) unit consists of an interrupt controller, a signal routing unit, and many peripherals:

- 8 or 4 serial ports (SPORT)
- Input Data Port (IDP)
- Four precision clock generators (PCG)
- Some family members have an S/PDIF receiver/transmitter
- Four asynchronous sample rate converters (ASRC)
- DTCP encryption

Interrupt Controller

The DAI contains its own interrupt controller that indicates to the core when DAI audio events have occurred. This interrupt controller offer 32 independently configurable channels.

Signal Routing Unit

Conceptually similar to a “patch-bay” or multiplexer, the SRU provides a group of registers that define the interconnection of the DAI peripherals to the DAI pins or to other DAI peripherals.

Digital Peripheral Interface (DPI)

The digital audio interface (DPI) unit consists of an interrupt controller, a signal routing unit, and many peripherals:

- 2 serial peripheral interface ports (SPI)
- 2 peripheral timers
- 1 or 2 UARTs
- 1 TWI controller (I²C compatible)

Interrupt Controller

The DPI contains its own interrupt controller that indicates to the core when DPI audio events have occurred. This interrupt controller offer 12 independently configurable channels.

Signal Routing Unit 2

Conceptually similar to a “patch-bay” or multiplexer, the SRU2 provides a group of registers that define the interconnection of the DPI peripherals to the DPI pins or to other DPI peripherals.

Development Tools

The processor is supported by a complete set of software and hardware development tools, including Analog Devices' emulators and the Cross-Core Embedded Studio or VisualDSP++ development environment. (The emulator hardware that supports other Analog Devices processors also emulates the processor.)

The development environments support advanced application code development and debug with features such as:

- Create, compile, assemble, and link application programs written in C++, C, and assembly
- Load, run, step, halt, and set breakpoints in application programs
- Read and write data and program memory
- Read and write core and peripheral registers
- Plot memory

Analog Devices DSP emulators use the IEEE 1149.1 JTAG test access port to monitor and control the target board processor during emulation. The emulator provides full speed emulation, allowing inspection and modification of memory, registers, and processor stacks. Nonintrusive in-circuit emulation is assured by the use of the processor JTAG interface—the emulator does not affect target system loading or timing.

Software tools also include Board Support Packages (BSPs). Hardware tools also include standalone evaluation systems (boards and extenders). In addition to the software and hardware development tools available from Analog Devices, third parties provide a wide range of tools supporting the Blackfin processors. Third party software tools include DSP libraries, real-time operating systems, and block diagram design tools.

Differences from Previous Processors

This section identifies differences between the ADSP-21367/8/9 and ADSP-2137x processors and previous SHARC processors: ADSP-21161, ADSP-21160, ADSP-21060, ADSP-21061, ADSP-21062, and ADSP-21065L. Like the ADSP-2116x family, the ADSP-2136x SHARC processor family is based on the original ADSP-2106x SHARC family. The ADSP-21367/8/9 and ADSP-2137x processors preserve much of the ADSP-2106x architecture and is code compatible to the ADSP-21160, while extending performance and functionality. For background information on SHARC processors and the ADSP-2106x family DSPs, see *ADSP-2106x SHARC User's Manual* or *ADSP-21065L SHARC DSP Technical Reference*.

I/O Architecture Enhancements

The I/O processor provides much greater throughput than the ADSP-2106x processors. This architecture incorporates two independent DMA buses versus the previous SHARC DMA controllers:

- one peripheral DMA bus (IOD0)
- one external port DMA bus (IOD1)

This allows to operate all external port DMA accesses independently from the peripheral busses since up to four internal memory blocks are addressable without any bus conflicts.

Differences from Previous Processors

2 I/O PROCESSOR

In applications that use extensive off-chip data I/O, programs may find it beneficial to use a processor resource other than the processor core to perform data transfers. The SHARC contains an I/O processor (IOP) that supports a variety of DMA (direct memory access) operations. Each DMA operation transfers an entire block of data. The I/O processor specifications are shown in [Table 2-1](#).

Table 2-1. I/O Processor Specifications

Feature	Availability
Total DMA channels	34
Rotating DMA channel priority	Yes
SPORT DMA channels	16
IDP DMA channel	8
UART DMA channel	4
SPI DMA channel	2
MTM/DTCP DMA channel	2
External Port DMA channel	2
PDAP DMA channel	1
DMA channel interrupts	16
Clock Operation	Peripheral clock (PCLK)

Features

I/O processor features are briefly described in the following list.

- Internal memory ↔ SPORT (DAI)
- Internal memory ← IDP (DAI) unidirectional
- Internal memory ↔ SPI
- Internal memory ↔ UART
- Internal memory ↔ External memory (External port)
- Internal memory ↔ Internal memory (MTM, External port)

By managing DMA, the I/O processor frees the processor core, allowing it to perform other operations while off-chip data I/O occurs as a background task. The multi-bank architecture of the processor's internal memory allows the core and IOP to simultaneously access the internal memory if the accesses are to different memory banks. This means that DMA transfers to internal memory do not impact core performance. The processor core continues to perform computations without penalty.

To further increase off-chip I/O, multiple DMAs can occur at the same time. The IOP accomplishes this by managing multiple DMAs of processor memory through the different peripherals. Each DMA is referred to as a *channel* and each channel is configured independently.

Register Overview

Two global IOP registers control the DMA arbitration over the I/O buses—the first for the peripheral bus and the second for the external port bus. This section provides brief descriptions of the major IOP registers. For complete information, see “[System Control Register \(SYSCTL\)](#)” on [page A-4](#) and “[External Port Registers](#)” on [page A-11](#).

System control register (SYSCTL). Controls the peripheral DMA operation for fixed or rotating DMA channel arbitration.

External port control register (EPCTL). Controls the external port DMA operation for fixed or rotating DMA channel arbitration and between the core and DMA.

DMA Channel Registers

The following sections provide information on the registers that control all DMA operations for each peripheral. Additional information on DMA operations can be found in specific peripheral chapters. Note that all DMA parameter registers are read-write (RW). For details of the DMA related registers, see “[Register Listing](#)” on [page A-186](#).

DMA Channel Allocation

Each DMA channel has a set of parameter registers which are used to set up DMA transfers. [Table 2-22 on page 2-32](#) shows the DMA channel allocation and parameter register assignments for the ADSP-2136x and ADSP-2137x processors.



DMA channels vary by processor model. For a breakdown of DMA channels for a particular model, see the appropriate product data sheet. Also note that each DMA channel has a specific peripheral assigned to it.

Standard DMA Parameter Registers

The parameter registers described below control the source and destination of the data, the size of the data buffer, and the step size used.

Index registers. Shown in [Table 2-2](#), provide an internal memory address, acting as a pointer to the next internal memory DMA read or write location. All internal index addresses are based on an internal memory offset of 0x80000.

Table 2-2. Index Registers

Register Name	Width (Bits)	Description
IISP0-7A	19	SPORTA
IISP0-7B	19	SPORTB
IISPI	19	SPI
IISPIB	19	SPIB
IDP_DMA_I0-7	19	IDP
IDP_DMA_I0-7A	19	IDP index A (ping pong)
IDP_DMA_I0-7B	19	IDP index B (ping pong)
IUART0RX	19	UART0 Receiver
IUART1RX	19	UART1 Receiver
IUART0TX	19	UART0 Transmitter
IUART1TX	19	UART1 Transmitter
IIMTMW	19	MTM Write
IIMTMR	19	MTM Read
IIEP0-1	19	External Port
EIEP0-1	28	External Port (external)

Modify registers. Shown in [Table 2-3](#), provide the signed increment by which the DMA controller post-modifies the corresponding memory index register after the DMA read or write.

Table 2-3. Modify Registers

Register Name	Width (Bits)	Description
IMSP0-7A	16	SPORTA
IMSP0-7B	16	SPORTB
IMSPI	16	SPI
IMSPIB	16	SPIB
IDP_DMA_M0-7	6	IDP
IDP_DMA_M0-7A	6	IDP modify A (ping pong)
IDP_DMA_M0-7B	6	IDP modify B (ping pong)
IMUART0RX	16	UART0 Receiver
IMUART1RX	16	UART1 Receiver
IMUART0TX	16	UART0 Transmitter
IMUART1TX	16	UART1 Transmitter
IMMTMW	16	MTM Write
IMMTMR	16	MTM Read
IMEP0-1	16	External Port
EMEP0-1	27	External Port (external)

DMA Channel Registers

Count registers. Shown in [Table 2-4](#), indicate the number of words remaining to be transferred to or from memory on the corresponding DMA channel.

Table 2-4. Count Registers

Register Name	Width (Bits)	Description
ICSP0-7A	16	SPORTA
ICSP0-7B	16	SPORTB
ICSPI	16	SPI
ICSPIB	16	SPIB
IDP_DMA_C0-7	16	IDP
CUART0RX	16	UART0 Receiver
CUART1RX	16	UART1 Receiver
CUART0TX	16	UART0 Transmitter
CUART1TX	16	UART1 Transmitter
ICMTMW	16	MTM Write
ICMTMR	16	MTM Read
ICEP0-1	16	External Port
ECEP0-1	16	External Port (external)

Chain pointer registers. Shown in [Table 2-5](#), chain pointer registers hold the starting address of the TCB (parameter register values) for the next DMA operation on the corresponding channel. These registers also control whether the I/O processor generates an interrupt when the current DMA process ends.

Table 2-5. Chain Pointer Registers

Register Name	Width (Bits)	Description
CPSP0-7A	29	SPORTA
CPSP0-7B	29	SPORTB
CPSPI	20	SPI
CPSPIB	20	SPIB
CPUART0RX	20	UART0 Receiver
CPUART1RX	20	UART1 Receiver
CPUART0TX	20	UART0 Transmitter
CPUART1TX	20	UART1 Transmitter
CPEP0-1	21	External Port

Extended DMA Parameter Registers

This section describes the enhanced parameter registers used for the external port.

Base registers. Shown in [Table 2-6](#), base registers indicate the start address of the circular buffer to be transferred to/from memory on the corresponding DMA channel.

DMA Channel Registers

Table 2-6. Base Registers

Register Name	Width (Bits)	Description
EBEP0-1	28	External Port (external base)

Length registers. Shown in [Table 2-7](#), define the length of the circular buffer to be transferred to/from memory on the corresponding DMA channel.

Table 2-7. Length Registers

Register Name	Width (Bits)	Description
ELEP0-1	26	External Port (external length)

Miscellaneous External Port Parameter registers. Shown in [Table 2-8](#), these registers are used for the delay line and scatter/gather DMA to read from tap list buffers, store counters and index pointers.

Table 2-8. Miscellaneous External Port Parameter Registers

Register Name	Width (Bits)	Description
RCEP	16	Delay line DMA read block size
REIP	19	Delay line DMA read internal index
RMEP	27	Delay line DMA read external modifier
TCEP	16	Delay line DMA tap list count
TPEP	19	Delay line DMA tap list pointer

Data Buffers

The data buffers or FIFOs (shown in [Table 2-9](#)) are used by each DMA channel to store data during the priority arbitration time period. The buffers (depending on the peripheral) are accessed by both DMA and the core. Note that all transmit buffers are write-only-to-clear (WOC) and all receive buffers are read-only-to-clear (ROC) bit types.

Table 2-9. Data Buffers

Buffer Name	FIFO Depth	Description
TXSP0-7A	2	SPORTA Transmit
TXSP0-7B	2	SPORTB Transmit
RXSP0-7A	2	SPORTA Receive
RXSP0-7B	2	SPORTB Receive
TXSPI	2	SPI Transmit
TXSPIB	2	SPIB Transmit
RXSPI	2	SPI Receive
RXSPIB	2	SPIB Receive
RXSPI_SHADOW	2	SPI Receive Shadow (RO)
RXSPIB_SHADOW	2	SPIB Receive Shadow (RO)
SPI DMA	4	DMA only
SPIB DMA	4	DMA only
IDP_FIFO	8	IDP FIFO Receive
UARTRBR0	1	UART0 Receiver
UARTRBR1	1	UART1 Receiver
UARTTHR0	1	UART0 Transmitter
UARTTHR1	1	UART1 Transmitter
MTM read/write	2	DMA only
DFEP0-1	6	DMA only
TPEP0-1	4	Delay Line DMA (ADSP-2136x only)
AMIRX	1	AMI Receive Packer
AMITX	1	AMI Transmit Packer
TXTWI8	1 (1 byte)	TWI Transmit
TXTWI16	1 (2 bytes)	TWI Transmit
RXTWI8	1 (1 byte)	TWI Receive
RXTWI16	1 (2 bytes)	TWI Receiver

Chain Pointer Registers

The chain pointer registers, described in [Table 2-10](#) (generic) and [Table 2-11](#) (external port) are 20 bits wide. The lower 19 bits are the memory address field. Like other I/O processor address registers, the chain pointer register's value is offset to match the starting address of the processor's internal memory before it is used by the I/O processor. On the SHARC processor, this offset value is 0x80000.

 The example chain pointer register shown in [Table 2-10](#) is valid for all peripherals unless otherwise noted.

Table 2-10. Generic Chain Pointer Register (CPx)

Bit	Name	Description
18–0	IIX address	Next chain pointer address
19	PCI	Program controlled interrupt 0 = interrupt after end of entire chain 1 = interrupt after current TCB

Table 2-11. External Port Chain Pointer Register (EPCPx)

Bit	Name	Description
18–0	IIX address	Next chain pointer address
19	PCI	Program controlled interrupt 0 = interrupt after end of entire chain 1 = interrupt after current TCB
20	CPDR	DMA direction for next TCB 0 = write to internal memory 1 = read from internal memory (ADSP-2137x only)

Bit 19 of the chain pointer register is the program controlled interrupt (PCI) bit. This bit controls whether an interrupt is latched after every DMA in the chain (when set = 1), or whether the interrupt is latched after the entire DMA sequence completes (if cleared = 0).

 The `PCI` bit only effects DMA channels that have chaining enabled. Also, interrupt requests enabled by the `PCI` bit are maskable with the `IMASK` register.

TCB Storage

This section lists all the different TCB memory allocations used for DMA chaining on the peripherals. Note that all TCBs must be located in internal memory.

Serial Port TCB

The serial ports support single and chained DMA. [Table 2-12](#) shows the required TCBs for chained DMA. Note that when using the serial ports, programs can insert a TCB in an active chain.

Table 2-12. SPORT TCBs

Address	Register
CP[18:0]	CPSPx Chain Pointer
CP[18:0] + 0x1	ICSPx Internal Count
CP[18:0] + 0x2	IMSPx Internal Modifier
CP[18:0] + 0x3	IISPx Internal Index

SPI TCB

[Table 2-13](#) shows the required TCBs for a SPI chained DMA.

TCB Storage

Table 2-13. SPI/SPIB TCBs

Address	Register
CP[18:0]	CPSPI/B Chain Pointer
CP[18:0] + 0x1	ICSPI/B Internal Count
CP[18:0] + 0x2	IMSPI/B Internal Modifier
CP[18:0] + 0x3	IISPI/B Internal Index

UART TCB

Table 2-14 shows the required TCBs for chained UART DMA.

Table 2-14. UART1–0 TCBs

Address	Register
CP[18:0]	CPUARTxRX/CPUARTxTX Chain Pointer
CP[18:0] + 0x1	ICUARTxRX/ICUARTxTX Internal Count
CP[18:0] + 0x2	IMUARTxRX/IMUARTxTX Internal Modifier
CP[18:0] + 0x3	IIUARTxRX/IIUARTxTX Internal Index

External Port TCB

The external port interface supports many different types of DMA, resulting in different lengths of TCBs. The TCB size varies from six locations (chained DMA) to 10 locations (circular scatter/gather DMA). Table 2-15 shows the required TCBs for chained DMA.



This TCB is also valid for the ADSP-21367/8/9 processors in circular buffering mode (the EBEP and ELEP registers are not part of the TCB).

Table 2-15. External Port TCBs for Standard DMA

Address	Register
CP[18:0]	CPEP
CP[18:0] + 0x1	EMEP
CP[18:0] + 0x2	EIEP
CP[18:0] + 0x3	ICEP
CP[18:0] + 0x4	IMEP
CP[18:0] + 0x5	IIEP

The order in which the descriptors are fetched with circular buffering enabled is shown in [Table 2-16](#).

Table 2-16. External Port TCBs for Circular DMA (ADSP-2137x Only)

Address	Register
CP[18:0]	CPEP
CP[18:0] + 0x1	ELEP
CP[18:0] + 0x2	EBEP
CP[18:0] + 0x3	EMEP
CP[18:0] + 0x4	EIEP
CP[18:0] + 0x5	ICEP
CP[18:0] + 0x6	IMEP
CP[18:0] + 0x7	IIEP

TCB Storage

For delay line DMA, TCB loading is split into two sequences to improve overall priority. The first TCB loads the write parameters and the second loads the read parameters. This two-stage loading is transparent to the application.

Table 2-17 shows the order in which descriptors are fetched with circular buffering enabled for ADSP-21367/8/9 processors.

Table 2-17. External Port TCBs for Delay Line DMA
(ADSP-21367/8/9 Only)

Address	Register
Delay Line Write	
CP[18:0]	CPEP
CP[18:0] + 0x1	TPEP
CP[18:0] + 0x2	RCEP
CP[18:0] + 0x3	RIEP
CP[18:0] + 0x4	ELEP
CP[18:0] + 0x5	EBEP
CP[18:0] + 0x6	EMEP
Delay Line Read	
CP[18:0] + 0x7	EIEP
CP[18:0] + 0x8	ICEP
CP[18:0] + 0x9	IMEP
CP[18:0] + 0xA	IIEP

Table 2-18 shows the order in which descriptors are fetched with circular buffering enabled for ADSP-2137x processors.

Table 2-18. External Port TCBs for Delay Line DMA (ADSP-2137x Only)

Address	Register
Delay Line Read	
CP[18:0]	CPEP
CP[18:0] + 0x1	TPEP
CP[18:0] + 0x2	TCEP
CP[18:0] + 0x3	RMEP
CP[18:0] + 0x4	RCEP
CP[18:0] + 0x5	RIEP
Delay Line Write	
CP[18:0] + 0x6	ELEP
CP[18:0] + 0x7	EBEP
CP[18:0] + 0x8	EMEP
CP[18:0] + 0x9	EIEP
CP[18:0] + 0xA	ICEP
CP[18:0] + 0xB	IMEP
CP[18:0] + 0xC	IIEP

TCB Storage

The order in which the descriptors are fetched for scatter/gather DMA with circular buffering enabled is shown in [Table 2-19](#) and [Table 2-20](#).

Table 2-19. External Port TCBs for Scatter/Gather DMA

Address	Register
CP[18:0]	CPEP
CP[18:0] + 0x1	TPEP
CP[18:0] + 0x2	TCEP
CP[18:0] + 0x3	EMEP
CP[18:0] + 0x4	EIEP
CP[18:0] + 0x5	ICEP
CP[18:0] + 0x6	IMEP
CP[18:0] + 0x7	IIEP

Table 2-20. External Port TCBs for Circular Scatter/Gather DMA

Address	Register
CP[18:0]	CPEP
CP[18:0] + 0x1	ELEP
CP[18:0] + 0x2	EBEP
CP[18:0] + 0x3	TPEP
CP[18:0] + 0x4	TCEP
CP[18:0] + 0x5	EMEP
CP[18:0] + 0x6	EIEP
CP[18:0] + 0x7	ICEP
CP[18:0] + 0x8	IMEP
CP[18:0] + 0x9	IIEP

Clocking

The fundamental timing clock of the IOP is peripheral clock ($PCLK$). All DMA data transfers over the IO0 or IO1 buses are clocked at $PCLK$ speed.

Functional Description

The following several sections provide detail on the function of the I/O processor.

Automated Data Transfer

Because the IOP registers are memory-mapped, the processors have access to program DMA operations. A program sets up a DMA channel by writing the transfer's parameters to the DMA parameter registers. After the index, modify, and count registers (among others) are loaded with a starting source or destination address, an address modifier, and a word count, the processor is ready to start the DMA.

The peripherals each have a DMA enable ($xDEN$) bits in their channel control registers. Setting this bit for a DMA channel with configured DMA parameters starts the DMA on that channel. If the parameters configure the channel to receive, the I/O processor transfers data words received at the buffer to the destination in internal memory. If the parameters configure the channel to transmit, the I/O processor transfers a word automatically from the source memory to the channel's buffer register. These transfers continue until the I/O processor transfers the selected number of words as determined by the count parameter. DMA through the IDP ports occurs in internal memory only.

DMA Transfer Types

Standard DMA. A standard DMA (once it is configured) transfers data from location A to location B. An interrupt can be used to indicate the end of the transfer. To start a new DMA sequence after the current one is finished, a program must first clear the DMA enable bit (control register), write new parameters to the index, modify, and count registers (parameter registers), then set the DMA enable bit to re-enable DMA (control register).

An instance where standard DMA can be used is to copy data from a peripheral to internal memory for processor booting. With the help of the loader tool, the tag (header information) of the boot stream is decoded to get the storage information which includes the index, modify, and count of a specific array to start another standard DMA.

Chained DMA. Chained DMA sequences are a set of multiple DMA operations, each autoinitializing the next in line. To start a new DMA sequence after the current one is finished, the IOP automatically loads new index, modify, and count values from an internal memory location (or external memory location for DMA to external ports) pointed to by that channel's chain pointer register. Using chaining, programs can set up consecutive DMA operations and each operation can have different attributes.

Chained DMA with direction on the fly (External Port). The external port DMA controller supports chained DMA sequences with the an additional feature that allows the port to change the data direction for each individual TCB. An additional bit in the TCB differentiates between a read or write operation.



The IDP port does not support DMA chaining.

Ping-pong DMA (IDP). In ping-pong DMA, the parameters have two memory index values (index A and index B), one count value and one modifier value. The DMA starts the transfer with the memory indexed by A. When the transfer is completed as per the value in the count register, the DMA restarts with the memory location indexed by B. The DMA restarts with index A after the transfer to memory with index B is completed as per the count value. This repeats until the DMA is stopped by resetting the DMA enable bit.

Circular Buffering DMA (External Port). This mode resembles the chained DMA mode, however two additional registers (base and length) are used. This mode performs DMA within the circular buffer, which is useful for filter implementation since core interaction is limited, conserving bandwidth.

DMA Direction

The IOP supports DMA in three directions. These are described in the following sections.

Internal to External Memory

DMA transfers between internal memory and external memory devices use the processor's external port. For these types of transfers, the application code provides the DMA controller with the internal memory buffer size, address, and address modifier, as well as the external memory buffer size, address, address modifier, and the direction of transfer. After setup, the DMA transfers begin when the program enables the channel and continues until the I/O processor transfers the entire buffer to processor memory. [Table 2-22 on page 2-32](#) shows the parameter registers for each DMA channel.

Functional Description

Peripheral to Internal Memory

Similarly, DMA transfers between internal memory and serial, IDP, or SPI ports have DMA parameters. When the I/O processor performs DMA between internal memory and one of these ports, the program sets up the parameters, and the I/O uses the port instead of the external bus.

The direction (receive or transmit) of the peripheral determines the direction of data transfer. When the port receives data, the I/O processor automatically transfers the data to internal memory. When the port needs to transmit a word, the I/O processor automatically fetches the data from internal memory. [Figure 2-1 on page 2-21](#) shows more detail on DMA channel data paths.

Internal Memory to Internal Memory

The ADSP-2136x and ADSP-2137x processors can use memory-to-memory DMA to transfer 64-bit blocks of data between internal memory locations.

DMA Controller Addressing

[Figure 2-1](#) shows a block diagram of the I/O processor's address generator (DMA controller). "[Standard DMA Parameter Registers](#)" on [page 2-4](#) lists the parameter registers for each DMA channel. The parameter registers are uninitialized following a processor reset.

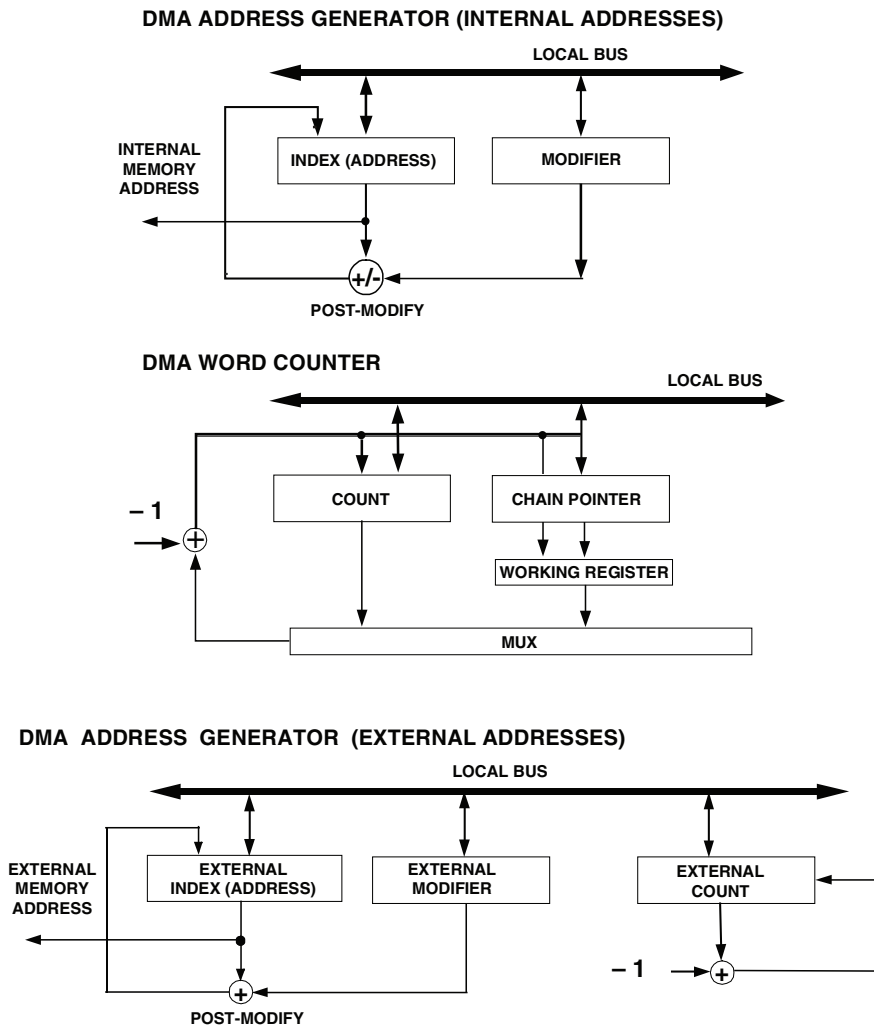

Figure 2-1. DMA Address Generator

Functional Description

The I/O processor generates addresses for DMA channels much the same way that the Data Address Generators (DAGs) generate addresses for data memory accesses. Each channel has a set of parameter registers including an index register and modify register that the I/O processor uses to address a data buffer in internal memory. The index register must be initialized with a starting address for the data buffer. As part of the DMA operation, the I/O processor outputs the address in the index register onto the processor's I/O address bus and applies the address to internal memory during each DMA cycle—a clock cycle in which a DMA transfer is taking place.

Internal Index Register Addressing

All addresses in the index registers are offset by a value matching the processor's first internal normal word addressed RAM location, before the I/O processor uses the addresses. For the products in this manual, this offset value is 0x0008 0000.

The following rules for data transfers must be followed.

- DMA index addresses must always be normal word space (32-bit).
- DMA Data packing can only happen in the associated peripheral, for example external port booting, the AMI does 8 to 32-bit packing via the external port DMA channel 0.



The DMA controller only supports index addresses in the normal word space (32-bit).

After transferring each data word to or from internal memory, the I/O processor adds the modify value to the index register to generate the address for the next DMA transfer and writes the modified index value to the index register. The modify value in the modify register is a signed integer, which allows both increment and decrement modifies. The modify value can have any positive or negative integer value. Note that:

- If the I/O processor modifies the internal index register past the maximum 19-bit value to indicate an address out of internal memory, the index wraps around to zero. With the offset for the SHARC processor, the wraparound address is 0x80000.
 - If a DMA channel is disabled, the I/O processor does not service requests for that channel, whether or not the channel has data to transfer.
-  If a program loads the count register with zero, the I/O processor does not disable DMA transfers on that channel. The I/O processor interprets the zero as a request for 2^{16} transfers. This count occurs because the I/O processor starts the first transfer before testing the count value. The only way to disable a DMA channel is to clear its DMA enable bit.

External Index Register Addressing

The external port DMA channels each contain additional parameter registers: the external index registers ($EIEP_x$), external modify registers ($EMEP_x$), and external count registers ($ECEP_x$). The DMA controller generates 28-bit external memory addresses over the IOD1 bus using the $EIEP_x$ register during DMA transfers between internal memory and external memory.

DMA Channel Status

There are two methods the processor uses to monitor the progress of DMA operations; interrupts, which are the primary method, and status polling. The same program can use either method for each DMA channel.

Programs can check the appropriate DMA status bits (for example the status bits in the $SPMCTL$ register for the serial ports) to determine which channels are performing a DMA or chained DMA. All DMA channels can be active or inactive. If a channel is active, a DMA is in progress on that

Functional Description

channel. The I/O processor indicates the active status by setting the channel's bit in the status register.

 Note that there is 1 PCLK cycle latency between a change in DMA channel status and the status update in the corresponding register.

The peripheral's DMA controller tracks status information of the channels in each of the peripheral registers (for example SPMCTLx, SPIDMACx, DAI_STAT, DMACx, and MTMCTL).

- DMA channel status (status bit is set until the DMA terminates)
- TCB chain loading status (status bit is set until TCB loading completes)

If polling the status of a chained DMA, the DMA status bit is first set when the TCB has terminated, then it is cleared. The TCB status loading bit is set until the load is finished and cleared on load completion. This procedure is repeated for all subsequent DMA blocks.

Note that polling the DMA status registers (especially chained DMA) reduces I/O bandwidth.

DMA Start and Stop Conditions

The difference between single DMA and chained DMA is based on the auto-linkage process where the DMA's attributes are stored in internal memory and automatically loaded by the IOP if requested.

A DMA sequence starts when one of the following occurs.

- Chaining is disabled, and the DMA enable bit transitions from low to high.
- Chaining is enabled, DMA is enabled, and the chain pointer register address field is written with a non zero value. In this case, TCB chain loading of the channel parameter registers occurs first.

- Chaining is enabled, the chain pointer register address field is non-zero, and the current DMA sequence finishes. Again, TCB chain loading occurs.

A DMA sequence ends when one of the following occurs.

- The count register decrements to zero, and the chain pointer register is zero.
- Chaining is disabled and the channel's DMA enable bit transitions from high to low. If the DMA enable bit goes low (=0) and chaining is enabled, the channel enters chain insertion mode (SPORT only) and the DMA sequence continues.

Once a program starts a DMA process, the process is influenced by two external controls; DMA channel priority and DMA chaining.

Operating Modes

This section provides information on IOP operating modes.

The SHARC processor contains two independent 32-bit DMA buses (Figure 2-2). The IOD0 bus is used for the peripherals to the internal memory and the IOD1 bus is used for external-to-internal memory transfers.

Operating Modes

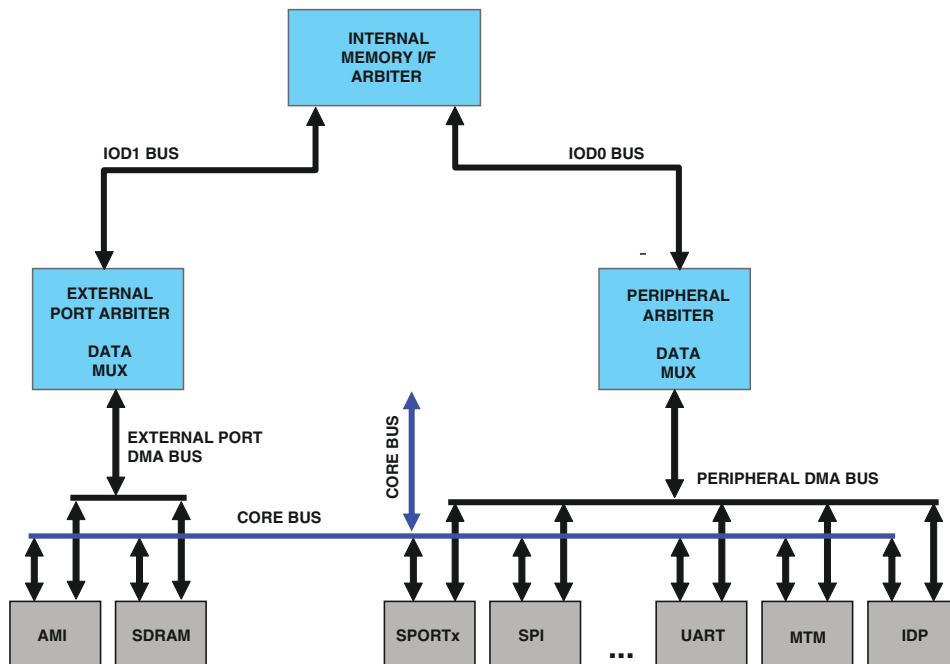

Figure 2-2. I/O Processor Bus Structure

The IOD0 bus is the path that the IOP uses to transfer data between internal memory and the peripherals. When there are two or more peripherals with active DMAs in progress, they may all require data to be moved to or from memory in the same cycle. For example, the SPI port may fill its buffer just as a SPORT shifts a word into its buffer. To determine which word is transferred first, the DMA channels for each of the processor's I/O ports negotiate channel priority with the I/O processor using an internal DMA request/grant handshake.



The IOD0 and IOD1 buses operate independently. However, in some cases there may be address conflicts if both buses access the same internal memory block. In this case, the IOD0 bus has first priority.

Each I/O port has one or more DMA channels, and each channel has a single request and a single grant. When a particular channel needs to read or write data to internal memory, the channel asserts an internal DMA request. The I/O processor prioritizes the request with all other valid DMA requests. When a channel becomes the highest priority requester, the I/O processor asserts the channel's internal DMA grant. In the next clock cycle, the DMA transfer starts. [Table 2-22 on page 2-32](#) shows the paths for internal DMA requests within the I/O processor.

DMA Chaining

In the SHARC processors, DMA data transfers can be set up as continuous or periodic. Furthermore, these DMA transfers can be configured to run automatically using chained DMA. With chained DMA, the attributes of a specific DMA are stored in internal memory and are referred to as a *Transfer Control Block* or TCB. The DMA controller loads these attributes in chains for execution. This allows for multiple chains that are a finite or infinite.



If chaining is enabled on a DMA channel, programs should not use polling to determine channel status as this gives inaccurate information where the DMA appears inactive if it is sampled while the next TCB is loading.

TCB Memory Storage

The location of the DMA parameters for the next sequence comes from the chain pointer register that points to the next set of DMA parameters stored in the processor's internal memory. In chained DMA operations, the processor automatically initializes and then begins another DMA transfer when the current DMA transfer is complete. Each new set of parameters is stored in a user-initialized memory buffer or TCB for a chosen peripheral. [Table 2-21](#) provides a brief description of the TCBs.

Operating Modes

Table 2-21. Principal TCB Allocation for a Serial Peripheral

Address	Register	Description
CPx	Chain pointer register	Chain pointer for DMA chaining
CPx + 0x1 (ICx)	Internal count register	Length of internal buffer
CPx + 0x2 (IMx)	Internal modify register	Stride for internal buffer
CPx + 0x3 (IIx)	Internal index register	Internal memory buffer

 The size of TCB varies and is based on the peripheral to be used: the SPORTs and SPI require four locations, the external port requires six to 13 locations. Allowing different TCB sizes reduces the memory load since only the required TCBs are allocated in internal memory.

Chain Assignment

The structure of a TCB is conceptually the same as that of a traditional linked-list. Each TCB has several data values and a pointer to the next TCB. Further, the chain pointer of a TCB may point to itself to continuously re run the same DMA. The I/O processor reads each word of the TCB and loads it into the corresponding register (see [Listing 2-1](#)).

 The address in the chain pointer register points to the highest address of the TCB (containing the index parameter). This means that if a program declares an array to hold the TCB, the chain pointer register should point to the last location of the array and not to the first TCB location.

Programs must assign the TCB in memory in the order shown in [Figure 2-3](#), placing the index parameter at the address pointed to by the chain pointer register of the previous DMA operation of the chain. The end of the chain (no further TCBs are loaded) is indicated by a TCB with a chain pointer register value of zero.

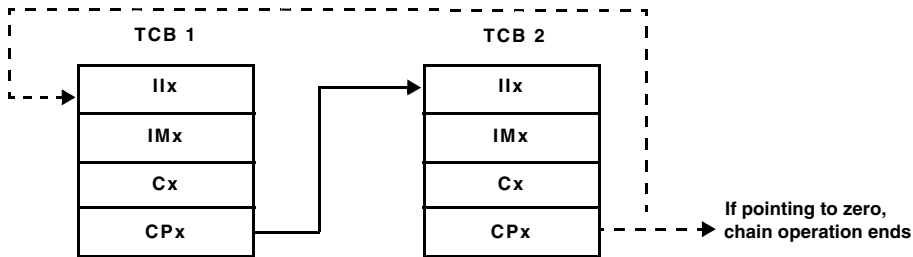

Figure 2-3. Chaining in the SPI and Serial Ports

The address field of the chain pointer registers is only 19 bits wide. If a program writes a symbolic address to bit 19 of the chain pointer there may be a conflict with the PCI bit. Programs should clear the upper bits of the address then AND the PCI bit separately, if needed, as shown below.

i Clear the chain pointer register before chaining is enabled.

Listing 2-1. Chain Assignment

Chain Assignment (according to [Figure 2-3](#)):

```

R0=0;
dm(CPx)=R0;          /* clear CPx register */

/* init DMA control registers */

R2=(TCB1+3) & 0x7FFFF; /* load IIX address of next TCB
                        and mask address */
R2=bset R2 by 19;     /* set PCI bit */
dm(TCB2)=R2;         /* write address to CPx location of
                    current TCB */
R2=(TCB2+3) & 0x7FFFF; /* load IIX address of next TCB and
                        mask address*/

R2=bclr R2 by 19;    /* clear PCI bit */

dm(TCB1)=R2;         /* write address to CPx location of
                    current TCB */

dm(CPx)=R2;         /* write IIX address of TCB1 to CPx
                    register to start chaining*/

```

Operating Modes

-  Chained DMA operations may only occur within the same channel. The processor does not support cross-channel chaining.

Starting Chain Loading

A DMA sequence is defined as the sum of the DMA transfers for a single channel, from when the parameter registers initialize to when the count register decrements to zero. Each DMA channel has a chaining enable bit (CHEN) in the corresponding control register.

To start the chain, write the internal index address of the first TCB to the chain pointer register. When chaining is enabled, DMA transfers are initiated by writing a memory address to the chain pointer register. This is also an easy way to start a single DMA sequence, with no subsequent chained DMAs.

During TCB chain loading, the I/O processor loads the DMA channel parameter registers with values retrieved from internal memory.

-  When starting chain loading, note that the SPI port is an exception to the above. To execute the first DMA in a chain for this peripheral, the DMA parameter registers also need to be explicitly programmed. [For more information, see “DMA Transfers” on page 12-20.](#)

The chain pointer register can be loaded at any time during the DMA sequence. This allows a DMA channel to have chaining disabled (chain pointer register address field = 0x0) until some event occurs that loads the chain pointer register with a non zero value. Writing all zeros to the address field of the chain pointer register also disables chaining.

TCB Chain Loading Priority

A TCB chain load request is prioritized like all DMA channels. Therefore, the TCB chain loading request has the same priority level as the DMA channel itself. The I/O processor latches a TCB loading request and holds it until the load request has the highest priority. If multiple chaining requests are present, the I/O processor services the TCB block for the highest priority DMA channel first.

 A channel that is in the process of chain loading cannot be interrupted by any other request (TCB, DMA channel). The chain loading sequence is atomic and the I/O bus is locked until all the DMA parameter registers are loaded. For a list of DMA channels in priority order, see [Table 2-22](#).

Chain Insert Mode (SPORTs Only)

It is possible to insert a single SPORT DMA operation or another DMA chain within an active SPORT DMA chain. Programs may need to perform insertion when a high priority DMA requires service and cannot wait for the current chain to finish. This is supported only for SPORT DMA channels only. [For more information, see Chapter 7, Serial Ports.](#)

Fixed DMA Channel Arbitration

The shaded region in [Table 2-22](#) (DMA channels 32 and 33) illustrates that the priority shown is only valid if the IOD1 bus (external port DMA channels) has a memory address block conflict with the IOD0 peripherals bus. Otherwise, the IOD1 bus operates fully independently. Also note the external port DMA channel changes priority, depending on the external index addresses. If an external index address is assigned to an internal index address, then the DMA channel priority will change.

Operating Modes

Table 2-22. DMA Channel 0–33 Priorities

DMA Channel Number	Peripheral Group	Control/Status Registers	Parameter Registers	Data Buffer	Description
IOD0 Peripheral Bus					
0 (Highest Priority)	A	SPCTL1, SPMCTL1	IISP1A, IMSP1A, CSP1A, CPSP1A	RXSP1A or TXSP1A	Serial Port 1A Data
1			IISP1B, IMSP1B, CSP1B, CPSP1B	RXSP1B or TXSP1B	Serial Port 1B Data
2		SPCTL0, SPMCTL0	IISP0A, IMSP0A, CSP0A, CPSP0A	RXSP0A or TXSP0A	Serial Port 0A Data
3			IISP0B, IMSP0B, CSP0B, CPSP0B	RXSP0B or TXSP0B	Serial Port 0B Data
4	B	SPCTL3, SPMCTL3	IISP3A, IMSP3A, CSP3A, CPSP3A	RXSP3A or TXSP3A	Serial Port 3A Data
5			IISP3B, IMSP3B, CSP3B, CPSP3B	RXSP3B or TXSP3B	Serial Port 3B Data
6		SPCTL2, SPMCTL2	IISP2A, IMSP2A, CSP2A, CPSP2A	RXSP2A or TXSP2A	Serial Port 2A Data
7			IISP2B, IMSP2B, CSP2B, CPSP2B	RXSP2B or TXSP2B	Serial Port 2B Data
8	C	SPCTL5, SPMCTL5	IISP5A, IMSP5A, CSP5A, CPSP5A	RXSP5A or TXSP5A	Serial Port 5A Data
9			IISP5B, IMSP5B, CSP5B, CPSP5B	RXSP5B or TXSP5B	Serial Port 5B Data
10		SPCTL4, SPMCTL4	IISP4A, IMSP4A, CSP4A, CPSP4A	RXSP4A or TXSP4A	Serial Port 4A Data
11			IISP4B, IMSP4B, CSP4B, CPSP4B	RXSP4B or TXSP4B	Serial Port 4B Data

Table 2-22. DMA Channel 0–33 Priorities (Cont'd)

DMA Channel Number	Peripheral Group	Control/Status Registers	Parameter Registers	Data Buffer	Description
12	D	IDP_CTL0, IDP_CTL1, IDP_PP_CTL, DAI_STAT	IDP_DMA_I0, IDP_DMA_M0, IDP_DMA_C0, IDP_DMA_I0A, IDP_DMA_I0B, IDP_DMA_PC0	IDP_FIFO	DAI IDP or PDAP (only channel 0 supports both)
13			IDP_DMA_I1, IDP_DMA_M1, IDP_DMA_C1, IDP_DMA_I1A, IDP_DMA_I1B, IDP_DMA_PC1		Serial Input DAI IDP Channel 1
14			IDP_DMA_I2, IDP_DMA_M2, IDP_DMA_C2, IDP_DMA_I2A, IDP_DMA_I2B, IDP_DMA_PC2		Serial Input DAI IDP Channel 2
15			IDP_DMA_I3, IDP_DMA_M3, IDP_DMA_C3, IDP_DMA_I3A, IDP_DMA_I3B, IDP_DMA_PC3		Serial Input DAI IDP Channel 3

Operating Modes

Table 2-22. DMA Channel 0–33 Priorities (Cont'd)

DMA Channel Number	Peripheral Group	Control/Status Registers	Parameter Registers	Data Buffer	Description
16	D	IDP_CTL0, IDP_CTL1, DAI_STAT	IDP_DMA_I4, IDP_DMA_M4, IDP_DMA_C4, IDP_DMA_I4A, IDP_DMA_I4B, IDP_DMA_PC4	IDP_FIFO	Serial Input DAI IDP Channel 4
17			IDP_DMA_I5, IDP_DMA_M5, IDP_DMA_C5, IDP_DMA_I5A, IDP_DMA_I5B, IDP_DMA_PC5		Serial Input DAI IDP Channel 5
18			IDP_DMA_I6, IDP_DMA_M6, IDP_DMA_C6, IDP_DMA_I6A, IDP_DMA_I6B, IDP_DMA_PC6		Serial Input DAI IDP Channel 6
19			IDP_DMA_I7, IDP_DMA_M7, IDP_DMA_C7, IDP_DMA_I7A, IDP_DMA_I7B, IDP_DMA_PC7		Serial Input DAI IDP Channel 7
20	E	SPICTL, SPIDMAC, SPIBAUD SPISTAT	IISPI, IMSPI, CSPI, CPSPI	RXSPI or TXSPI and DMA Buffer	SPI Data
21	G	SPICTLB, SPIDMACB, SPIBAUDB, SPISTATB	IISPIB, IMSPIB, CSPIB, CPSPIB	RXSPIB or TXSPIB and DMA Buffer	SPI B Data
22	H	MTMCTL (or DTCP)	IIMTMW, IMMTMW, CMTMW	MTM FIFO	Memory-to- memory write data

Table 2-22. DMA Channel 0–33 Priorities (Cont'd)

DMA Channel Number	Peripheral Group	Control/Status Registers	Parameter Registers	Data Buffer	Description
23	I	MTMCTL (or DTCP)	IIMTMR, IMMTMR, CMTMR	MTM FIFO	Memory-to-memory read data
24	J	UART0RXCTL, UART0RX-STAT	IUART0RX, IMUART0RX, CUART0RX, CPUART0RX,	UART0RBR	UART0 Receive Buffer Register
25	J	UART0TXCTL, UART0TX-STAT	IUART0TX, IMUART0TX, CUART0TX, CPUART0TX,	UART0THR	UART0 Transmit Holding Register
26	J	UART1RXCTL, UART1RX-STAT	IUART1RX, IMUART1RX, CUART1RX, CPUART1RX,	UART1RBR	UART1 Receive Buffer Register
27	J	UART1TXCTL, UART1TX-STAT	IUART1TX, IMUART1TX, CUART1TX, CPUART1TX,	UART1THR	UART1 Transmit Holding Register
28	L	SPCTL7, SPMCTL7	IISP7A, IMSP7A, CSP7A, CPSP7A	RXSP7A or TXSP7A	Serial Port 7A Data
29	L		IISP7B, IMSP7B, CSP7B, CPSP7B	RXSP7B or TXSP7B	Serial Port 7B Data
30	L	SPCTL6, SPMCTL6	IISP6A, IMSP6A, CSP6A, CPSP6A	RXSP6A or TXSP6A	Serial Port 6A Data
31	L		IISP6B, IMSP6B, CSP6B, CPSP6B	RXSP6B or TXSP6B	Serial Port 6B Data

Operating Modes

Table 2-22. DMA Channel 0–33 Priorities (Cont'd)

DMA Channel Number	Peripheral Group	Control/Status Registers	Parameter Registers	Data Buffer	Description
IOD1 External Port Bus					
32	Q	DMAC0	IIEP0, IMEP0, ICEP0, EIEP0, EMEP0, ELEP0, EBEP0, RIEP0, RCEP0, RMEP0, TCEP0, TPEP0, CPEP0	DFEP0 and AMIRX AMITX (AMI only)	External Port Memory DMA 0
33	R	DMAC1	IIEP1, IMEP1, ICEP1, EIEP1, EMEP1, ELEP1, EBEP1, RIEP1, RCEP1, RMEP1, TCEP1, TPEP1, CPEP1	DFEP1 and AMIRX AMITX (AMI only)	External Port Memory DMA 1. Note if the DMAC0 channel runs int-int memory and DMAC1 channel int-ext memory, then DMAC1 has higher priority (ADSP-2137x only).

Peripheral DMA Bus

DMA-capable peripherals execute DMA data transfers to and from internal memory over the IOD0 bus. When more than one of these peripherals requests access to the IOD0 bus in a clock cycle, the bus arbiter, which is attached to the IOD0 bus, determines which master should have access to the bus and grants the bus to that master.

IOP channel arbitration can be set to use either a fixed or rotating algorithm by setting or clearing `RPBR` bit in the `SYSCTL` register as follows.

- (=0) fixed arbitration (default)
- (=1) rotating arbitration

In the fixed priority scheme, the lower indexed peripheral has the highest priority.

External Port DMA Bus

External port DMA channels transfer data between internal memories or between internal and external memory over the IOD1 bus. When both external port channels request access to the IOD1 bus in a clock cycle, the external port bus arbiter, which is attached to the IOD1 bus, determines which master should have access to the bus and grants the bus to that master.

IOP/external port channel arbitration can be set to use either a fixed or rotating algorithm by setting or clearing the `DMAPR` bits in the `EPCTL` register as follows.

- (=10) fixed arbitration channel 0
- (=11) rotating arbitration (default)

Note the independency is only broken if there is an internal memory block conflict. In this case, if both rotating bits are set, the peripheral DMA channels always have the highest priority and the `DMAPR` bit allows the change in priority among the two external port DMA channels.

Rotating DMA Channel Arbitration

DMA channel arbitration is the method that the arbiter uses to determine how groups rotate priority with other channels. The default DMA channel priority is fixed prioritization by DMA channel group.

Interrupts

Rotating Priority by Group

In the rotating priority scheme, the default priorities at reset are the same as that of the fixed priority. However, the peripheral priority is determined by group, not individually by DMA channel. Peripheral groups are shown in [Table 2-22 on page 2-32](#).

Initially, group A has the highest priority and group I the lowest. As one group completes its DMA operation, it is assigned the lowest priority (moves to the back of the line) and the next group is given the highest priority.

When none of the peripherals request bus access, the highest priority peripheral, for example, peripheral 0, is granted the bus. However, this does not change the currently assigned priorities to various peripherals.

Within a peripheral group, the priority is highest for the higher indexed peripheral (see [Table 2-22 on page 2-32](#)). For example, of the SPORT pair SP01 (which is in group A), SP1 has the highest priority.

Programs can change DMA arbitration modes between fixed and rotate on the fly which incurs an effect latency of 2 PCLK cycles.

Interrupts

The primary type of DMA communication is interrupt driven I/O where the core continues to execute instructions while DMA executes in the background. This allows high levels of parallelism achieving over all better system performance. Because the interrupt vector directs the core to respond to specific transactions very efficiently, programs do not need to poll status bits.

During interrupt-driven DMA, programs use the interrupt mask bits in the IMASK, LIRPTL, DPI_IMASK, DAI_IMASK_x registers to selectively mask DMA channel interrupts that the I/O processor latches into the IRPTL, LIRPTL, DPI_IRPTL, DAI_IRPTL_x registers. A channel interrupt mask in the

IMASK, LIRPTL, DPI_IMASK, DAI_IMASK_x registers determines whether a latched interrupt is serviced or not. When an interrupt is masked, it is latched but not serviced.

Sources

The following sections describe the two sources of interrupts.

Unchained DMA Interrupts

When an unchained (single block) DMA process reaches completion (the DMA count decrements to zero) on any DMA channel, the I/O processor latches that DMA channel's interrupt. It does this by setting the DMA channel's interrupt latch bit in the IRPTL, LIRPTL, DPI_IRPTL, or DAI_IRPTLH_x registers.

Chained DMA Interrupts

For chained DMA, the channel generates interrupts in one of two ways:

1. If $PCI = 1$, (bit 19 of the chain pointer register is the program controlled interrupts, or PCI bit) an interrupt occurs for each DMA in the chain.
2. If $PCI = 0$, an interrupt occurs at the end of a completed chain. For more information on DMA chaining, see [“Functional Description” on page 2-17](#).

[Figure 2-4](#) shows the PCI timing during TCB loading. After the DMA count for the last word of frame N becomes zero, the PCI interrupt is latched. At the same time the DMA reloads the TCB for that specific channel (assuming no higher priority DMA requests). Finally the DMA channel resumes operation for frame N-1.

Interrupts

- i** By clearing a channel's PCI bit during chained DMA, programs mask the DMA complete interrupt for a DMA process within a chained DMA sequence.

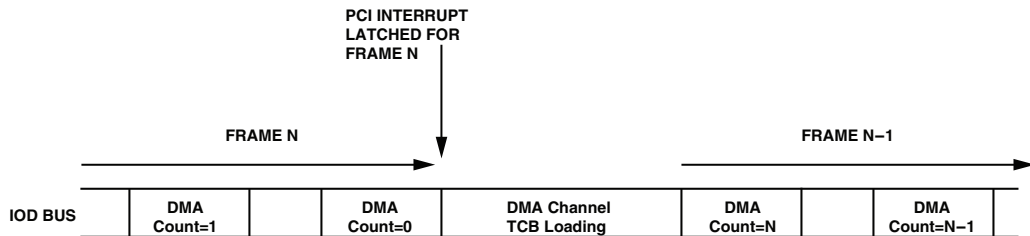

Figure 2-4. DMA Chaining

Transfer Completion Types

The next two sections describe the two types of interrupts that are used to signal interrupt completion. These are based on the type of peripheral used.

Internal Transfer Completion

This mode of interrupt generation resembles the traditional SHARC DMA interrupt generation. The interrupt is generated once the DMA internal transfers are complete, independent of whether the DMA is a transmit or receive. Therefore, for external transmit DMAs, when the completion interrupt is generated there may still be an external access pending at the external DMA interface.

- i** The I/O processor only generates a DMA complete interrupt when the channel's count register decrements to zero as a result of actual DMA transfers. Writing zero to a count register does not generate the interrupt. To stop a DMA preemptively, write a one to the count register. This causes one additional word to be transferred or received, and an interrupt is then generated.

Access Completion

A DMA complete interrupt is generated when accesses are finished. For an external write DMA, the DMA complete interrupt is generated only after the external writes on the DMA external interface are complete. For an external read DMA, the complete interrupt is generated when the internal DMA writes are complete. In this DMA mode the DMA interface could be disabled as soon as the interrupt is received.

This mode is supported by the external port on the ADSP-2137x processors only.

Core Single Word Transfer Interrupts

When a DMA channel's buffer is not being used for a DMA process, the core can generate an interrupt on single word transfers (writes or reads) of the buffer of the respective peripheral. This interrupt service differs slightly for each peripheral. In this case, the peripheral's buffer generates an interrupt when data becomes available at the receive buffer or when the transmit buffer is not full (when there is room for the core to write to the buffer). Generating interrupts in this manner lets programs implement interrupt-driven I/O under control of the processor core. Refer to the specific peripheral chapter for more information.

Interrupt Versus Channel Priorities

At their default setting shown in [Table 2-23](#), the DMA interrupt priorities do not match the DMA channel priorities. However, if both priorities schemes should match, the DMA interrupt priorities can be re-assigned by dedicated settings of the `PICRx` registers.

Debug Features

Table 2-23. Default Channel vs. Interrupt Priorities

Programmable Interrupt	Default Interrupt Priority	Priorities	DMA Channel Priority (EPDMA on Separate DMA Bus)	
P0I	DAIHI	Highest	SPORT5–0, 12 channels IDP7–0, 8 channels SPI – 1 channel SPI B – 1 channel MTM (WR/RD) – 2 channels UART0(Tx/Rx) – 2 channels UART1(Tx/Rx) – 2 channels SPORT7–6, 4 channels	
P1I	SPII			
P3I	SP1I			
P4I	SP3I			
P5I	SP5I			
P6I	SP0I			
P7I	SP2I			
P8I	SP4I			
P9I	EP0I			
P11I	SP7I			
P12I	DAILI			
P13I	EP1I			
P14I	DPII			
P15I	MTMI			
P16I	SP6I			
P18I	SPIBI			Lowest

Debug Features

The JTAG interface provides some user debug features for DMA in that it allows programs to place breakpoints on the IOD buses. Programmers can then insert DMA related breakpoints. For more information, see the CrossCore or VisualDSP++ tools documentation and *SHARC Processor Programming Reference*.

Emulation Considerations

An emulation halt will optionally stop the DMA engine. The JTAG interface provides some user debug features for DMA. Placing breakpoints on the IOD address buses allows DMA related breakpoints. For more information, see the tools documentation and *SHARC Processor Programming Reference*.

Effect Latency

The total effect latency is a combination of the write effect latency (core access) plus the peripheral effect latency (peripheral specific).

Write Effect Latency

For details on write effect latency, see *SHARC Processor Programming Reference*.

IOP Effect Latency

[Table 2-24](#) lists the time required to load a specific TCB from the internal memory into the DMA controller. During this time, both buses (for a peripheral DMA, the IOD0 bus and for external port DMA the IOD1 bus) are locked and cannot be interrupted.

IOP Throughput

Since the I/O processor controls two I/O buses (peripheral and external port) the maximum bandwidth per IOD bus is gained for:

- Internal memory writes with $f_{\text{PCLK}} \times 32\text{-bit}$
- Internal memory reads with $f_{\text{PCLK}}/2 \times 32\text{-bit}$

Programming Model

assuming no address conflict in internal memory. [Table 2-24](#) shows the number of core clock cycles needed to execute a chained TCB.

Table 2-24. I/O Processor TCB Chain Loading Access

Chained TCB Type	TCB Size	Number of Core Cycles
SPI DMA, SPORT DMA	4	26
External Port standard DMA, Delay Line DMA read	6	34
External Port Circular Buffer DMA, Delay Line DMA write	7	40
External Port Scatter/Gather DMA	8	42
External Port Circular Buffer Scatter/Gather DMA	10	50

Programming Model

The following sections describe the programming model for the I/O processor.

General Procedure for Configuring DMA

To configure the processors to use DMA, use the following general procedure. Note this is a generic model. For specific information refer to the individual programming model section in the peripheral-specific chapter.

1. Clear all relevant registers (DMA/peripheral control, chain pointer).
2. Determine interaction method (enable `IRQEN/IMASK` setting or status polling).
3. Define the DMA channels interrupt priority (`PICR` registers).
4. Determine the DMA channel priority (fixed or rotating).

5. Determine the DMA address region for source and destination (index, modifier, count).
6. Determine the DMA transfer type (standard, chained, circular).
7. Set the DMA enabled bit/write index address of first TCB to the chain pointer register.

Programming Model

3 EXTERNAL PORT

The external port interface houses the external port access arbitration, the AMI (asynchronous memory interface) the SDRAM controller (synchronous DRAM) and the shared memory interface (ADSP-21368 only). The external port allows memory mapped access to the external world with the help of up to four memory banks.

The interface specifications are shown in [Table 3-1](#).

Table 3-1. External Port Specifications

Feature	Asynchronous Memory Interface	SDRAM Interface
Connectivity		
Multiplexed Pinout	Yes (External Port)	Yes (External Port)
SRU DAI Required	No	No
SRU DAI Default Routing	N/A	N/A
SRU2 DPI Required	No	No
SRU2 DPI Default Routing	N/A	N/A
Interrupt Control	Yes	Yes

Features

Table 3-1. External Port Specifications (Cont'd)

Feature	Asynchronous Memory Interface	SDRAM Interface
Protocol		
Master Capable	Yes	Yes
Slave Capable	No	No
Transmission Simplex	Yes	Yes
Transmission Half-Duplex	Yes	Yes
Transmission Full-Duplex	No	No
Access Type		
Data Buffer	Yes	Yes
Core Data Access	Yes	Yes
DMA Data Access	Yes	Yes
DMA Channels	2	2
DMA Chaining	Yes	Yes
Boot Capable	Yes	No
Clock Operation	SDCLK	SDCLK

Features

The external ports contain are described in the following list.

- Supports access to the external memory by core and DMA accesses. The external memory address space is divided in to four banks. Any bank can be programmed as either asynchronous or synchronous memory.
- An asynchronous memory interface which communicates with SRAM, FLASH, and other devices that meet the standard asynchronous SRAM access protocol.

- A SDRAM controller that supports a glue-less interface with any of the standard SDRAMs.
- Arbitration Logic to coordinate core and DMA transfers between internal and external memory over the external port.
- External code execution supported from 8-, and 16-, and 32-bit AMI/SDRAM.
- Dual data fetch instruction (Type 1) to external memory (ADSP-2137x only) and support for conditional instruction access for SDRAM and AMI.
- External port supports various ratios of CCLK to SDCLK determined by programming bits in the power management control registers (PMCTL). [For more information, see “Power Management Control Registers \(PMCTL\)” on page A-7.](#)
- A cluster of up to four ADSP-21368 processors to create shared external bus systems (ADSP-21368 only).

Note that previous ADSP-2126x/ADSP-2136x SHARC processors have a parallel port (multiplexed address/data bus). In the ADSP-21367/8/9 and ADSP-2137x processors the external port allows direct core access to external memory, and supports glueless SDRAM/AMI. Furthermore, the external port supports two separate DMA channels.

Pin Descriptions

For the external port pin descriptions of the AMI and SDRAM interfaces, see the appropriate processor-specific data sheet.

For proper booting to take place, ensure that the DSP whose ID is 001 comes out of reset earlier or at the same time as other DSPs. If that DSP comes out of reset later than any other DSP, synchronization issues prevent any processor from booting. If the tSRST spec in the datasheet is met, it could be ensured that all the DSPs come out of reset at the same time.

Pin Multiplexing

The external port pins are multiplexed together with Flag, PWM and PDAP pins. For more information on multiplexing schemes refer to [“Pin Multiplexing” on page 17-27](#).

Register Overview

This section provides brief descriptions of the major registers. The registers are listed for the external port, AMI and SDRAM controller. For complete register information, see [Appendix A, Registers Reference](#).

External Port Control Register (EPCTL). This register enables the external banks for the SDRAM or the AMI. Moreover controls accesses between the processor core and DMA, and between different DMA channels.

Power Management Control Register (PMCTL). Controls the $SDCLK$ to core clock ratio related to the AMI or SDRAM timing.

AMI Control Registers (AMICTLx). These registers control the mode of operations for the four banks of external memory. Note for all AMI timing bit settings, all defined cycles are derived from the SDRAM clock.

AMI Status Register (AMISTAT). This register provides status information for the AMI interface and can be read at any time.

SDRAM Control Register (SDCTL). Configures various aspects of SDRAM operation. These are control clock operation, bank configuration, and SDRAM commands. Programmable parameters associated with the SDRAM access timing.

SDRAM Control Status Register (SDSTAT). Provides information on the state of the controller. This information can be used to determine when it is safe to alter SDRAM control parameters or as a debug aid.

SDRAM Refresh Rate Control Register (SDRRC). Provides a flexible mechanism for specifying auto-refresh timing.

Shared Memory Control (SYSCTL). Provides control settings on the shared memory logic.

Shared Memory Status (SYSTAT). Provides status information on the shared memory arbitration logic.

Clocking

The fundamental timing clock of the external port is SDRAM clock (SDCLK).

The AMI/SDRAM controller is capable of running at up to 166 MHz and can run at various frequencies, depending on the programmed SDRAM clock (SDCLK) to core clock (CCLK) ratios. The various possible AMI/SDRAM clock to core clock frequency ratios are shown in [Table 3-2](#).

Functional Description

For information processor instruction rates, see the appropriate processor data sheets.

 The SDRAM clock ratio settings are independent from the peripheral clock (PCLK).

Table 3-2. SDRAM Controller Clock Frequencies

CCLK:SDCLK Clock Ratio	CCLK = 400 MHz	CCLK = 333 MHz	CCLK = 266 MHz	CCLK = 200 MHz
1:2.0	N/A	166	133	100
1:2.5	160	133	106	80
1:3.0	133	111	88	67
1:3.5	114	95	76	57
1:4.0	100	83	66	25

 To obtain certain higher SDRAM frequencies, the core frequency may need to be reduced.

Functional Description

The external port ([Figure 3-1](#)) has three ports for communication:

- Peripheral core bus for control of external port IOP registers
- External port core bus for core access to external memory banks
- External port DMA bus for transfers between the external port and internal memory

As shown in [Figure 3-1](#), the external port is a fundamental block since every access in the external memory space is handled by this port. The AMI or the SDRAM controller modules act as peripherals to the external world and as such they are responsible for filling the buffers with data

based on the protocol used. The external port also keeps track of the two DMA channels which can serve as data streams via the external and internal memory. The optional shared memory module allows ADSP-21368 processors to share data between up to 4 processors in a system.

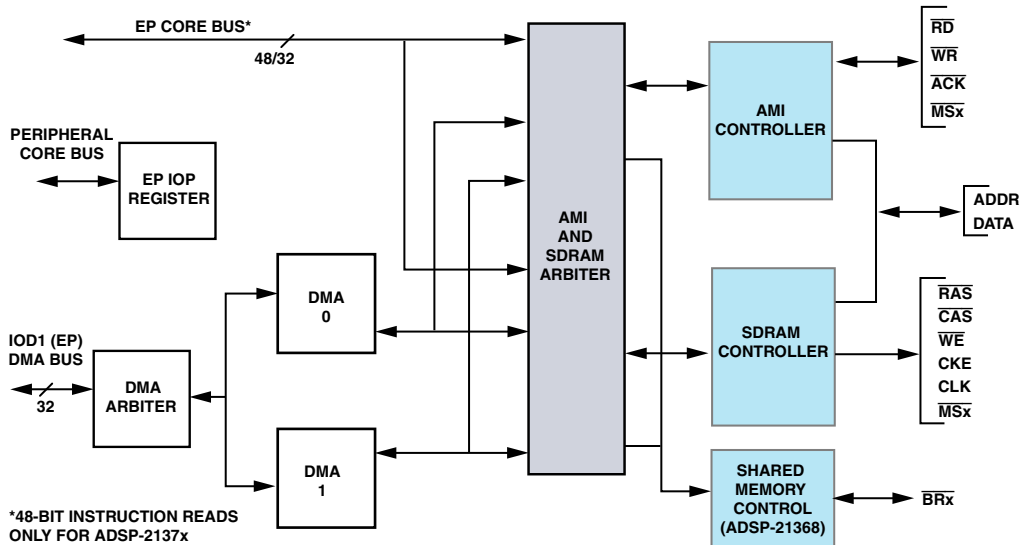

Figure 3-1. External Port Functional Block Diagram

External Port Arbitration

The external port uses a two stage arbitration process whereby all DMA requests need to pass the first stage until one request wins. The winning DMA channel then has a last arbitration process with the core.

1. External port DMA channels 0/1 rotating priority or high/low priorities.
2. Winning DMA channel arbitrating with core access.

Asynchronous Memory Interface

In the EPCTL register, the EBPR and DMAPR bits define the priorities. All the bits of EPCTL register can be changed only when the external port is idle (when all DMA engines are IDLE and no core accesses to external memory are pending).

External Port Bus Arbitration Conflicts

There is a 3:1 bus conflict resolution ratio at the external port interface. The three internal buses DMD, PMD and IOD1 to one external bus, in addition to the 2:1 or greater clock ratio between the processor's internal clock and the external SDRAM clock (SDCLK). Systems that feed data through the external port must tolerate at least one cycle-and possibly many additional cycles.

Channel Freezing

When multiple DMA channels are reading data from SDRAM memory, channel freezing can improve the data throughput. By setting the freeze bits in the EPCTL register (FRZDMA, bits 10–9 and FRZCR, bits 14–13), each channel is frozen for programmed accesses. For example, if the processor core is frozen for 32 accesses, and if the core requests 32 accesses to SDRAM sequentially, data throughput improves.

Freezing is based on the fact that sequential accesses to the SDRAM provide better throughput than non-sequential accesses.

 Channel freezing has no effect on write accesses.

Asynchronous Memory Interface

The ADSP-2137x SHARC processors support a glueless interface with any of the standard SRAMs. The AMI controller can support up to 62M words of SRAMs in four banks. Bank 0 can accommodate up to 14M words, and banks 1, 2, and 3 can accommodate up to 16M words each.

AMI Features

The AMI has the following features and capabilities.

- Clock Speed up to 166 MHz with I/O supply of 3.3 V
- User defined combinations of programmable wait states
- External hardware acknowledge signals
- Data packing support for 8/16 to 32 bits
- External instruction fetch from 8, 16 and 32 bits (ADSP-2137x)
- Both the processor core and the I/O processor have access to external memory using the AMI

Functional Description

The following sections provide a functional overview of the asynchronous memory interface.

The Asynchronous Memory Interface communicates with SRAM, FLASH and any other memory device that conforms to its protocol. It provides a DMA interface between internal memory and external memory, performs instruction (48-bit) fetch from external memory, and directs core access to external memory locations. It supports 8, 16 and 32-bit data access to external memory.

The AMI also supports 48-bit data packing for instruction fetch. The AMI supports 16M Words of external memory in Bank 1, Bank 2, Bank 3 and 12M Words of external memory in Bank 0. The maximum external data is 64M bytes on Bank 1. A core access (read/write) takes a minimum of 3 peripheral clock cycles to complete.

Asynchronous Memory Interface

The external interface follows standard asynchronous SRAM access protocol. The programmable wait states, hold cycle and idle cycles are provided to interface memories of different access times. To extend access the $\overline{\text{ACK}}$ signal can be pulled low by the external device as an alternative to using wait states.

Asynchronous Reads

Figure 3-2 shows an asynchronous read bus cycle. Asynchronous read bus cycles proceed as follows.

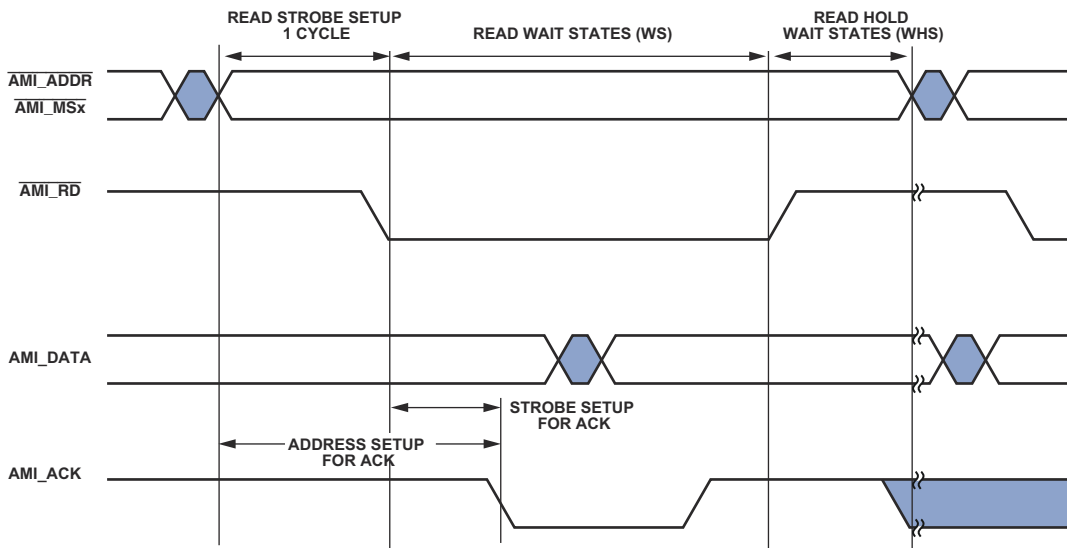

Figure 3-2. AMI Asynchronous Reads

1. At the start of the setup period, $\overline{\text{MSx}}$ and $\overline{\text{RD}}$ assert. The address bus becomes valid.
2. At the beginning of the read access period $\overline{\text{RD}}$ asserts.
3. After 3 cycles the read strobe is de-asserted, which samples the current data followed by the start of hold period.

- At the end of the hold period, some $\overline{\text{TDL}}\overline{\text{E}}$ cycles happened in the case the read is followed by a write. Also, $\overline{\text{MSx}}$ de-asserts unless the next cycle is to the same memory bank.

Asynchronous Writes

Figure 3-3 shows an asynchronous write bus cycle. Asynchronous write bus cycles proceed as follows.

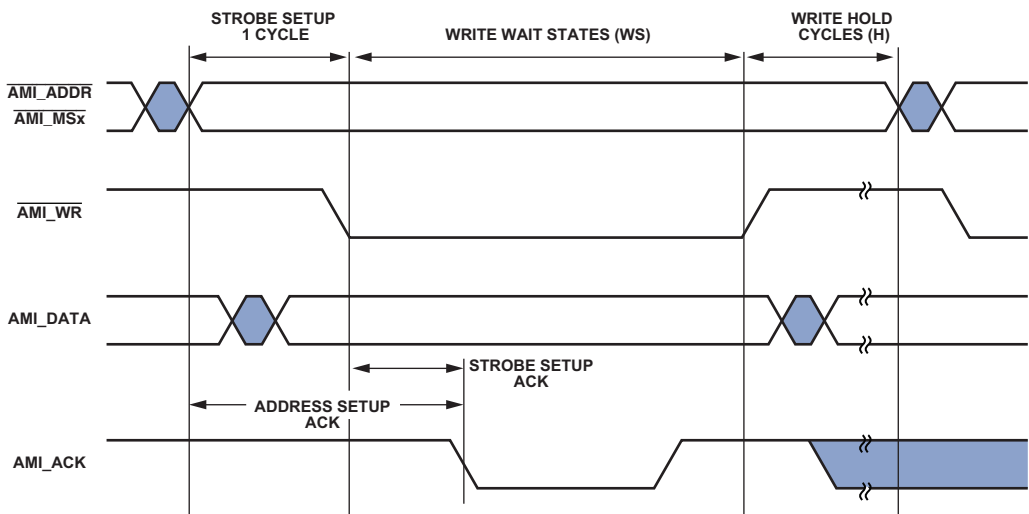

Figure 3-3. AMI Asynchronous Writes

- At the start of the setup period, $\overline{\text{MSx}}$, the address bus, data buses, become valid.
- At the beginning of the write access period, $\overline{\text{WR}}$ asserts.
- At the beginning of the hold period, $\overline{\text{WR}}$ de-asserts.
- One hold cycle is introduced before next access can happen. Also, $\overline{\text{MSx}}$ de-asserts unless the next cycle is to the same memory bank.

Asynchronous Memory Interface

Parameter Timing

This section describes the programmable timing parameter for the AMI. The AMI controller allows to program access timing parameters (wait states for idle or hold cycles) with the effect being flexible and efficient whether initiation is from the core or from DMA, and the sequence of transactions (read followed by read, read followed by write, and so on). Note that the strobe setup time is fixed to one $SDCLK$ cycle.

Idle Cycles

An idle cycle is inserted by default for an AMI read followed by write or a read followed by a read from a different bank or a read followed by an external access by another device in order to provide bus contention.

If an idle cycle is programmed for a particular bank, then a minimum of 1 idle cycle is inserted for reads even if they are from the same bank. In order to achieve better read throughput, an idle cycle should be programmed as 0. For more information refer to the product-specific data sheet.

Address Mapping

The processors have the ability to use logical addressing when an external memory smaller than 32 bits is used. When logical addresses are used, multiple external addresses seen by the memory correspond to a single internal address, depending on the width of the memory being accessed, and the packing mode setting of the AMI controller. The external physical address map is shown in [Table 3-3](#).



External memory address space is supported in normal word addressing mode only. Extended precision, short word and long word addressing modes are not supported.

Table 3-3. AMI Address Memory Map

Bus Width/Data Packing	External BANK	Logical Address	Physical Address
32-bit (or PKDIS=1)	0	0x0020_0000 to 0x00FF_FFFF	0x0020_0000 to 0x00FF_FFFF
32-bit (or PKDIS=1)	1	0x0400_0000 to 0x04FF_FFFF	0x0400_0000 to 0x04FF_FFFF
	2	0x0800_0000 to 0x08FF_FFFF	0x0800_0000 to 0x08FF_FFFF
	3	0x0C00_0000 to 0x0CFF_FFFF	0x0C00_0000 to 0x0CFF_FFFF
16-bit (and PKDIS=0)	0	0x0020_0000 to 0x007F_FFFF	0x0040_0000 to 0x00FF_FFFF
16-bit (and PKDIS=0)	1	0x0400_0000 to 0x047F_FFFF	0x0400_0000 to 0x04FF_FFFF
	2	0x0800_0000 to 0x087F_FFFF	0x0800_0000 to 0x08FF_FFFF
	3	0x0C00_0000 to 0x0C7F_FFFF	0x0C00_0000 to 0x0CFF_FFFF
8-bit (and PKDIS=0)	0	0x0020_0000 to 0x003F_FFFF	0x0080_0000 to 0x00FF_FFFF
8-bit (and PKDIS=0)	1	0x0400_0000 to 0x043F_FFFF	0x0400_0000 to 0x04FF_FFFF
	2	0x0800_0000 to 0x083F_FFFF	0x0800_0000 to 0x08FF_FFFF
	3	0x0C00_0000 to 0x0C3F_FFFF	0x0C00_0000 to 0x0CFF_FFFF

Operating Modes

The AMI operating modes are described in the following sections.

Data Packing

The combination of the BW, PKDIS and MSWF bits allow different combinations of data packing. These modes are summarized in [Table 3-4](#).

Asynchronous Memory Interface

Table 3-4. Data Packing Bit Settings (PKDIS)

BW Bits	PKDIS Bit	MSBF Bit	Description
32	1	N/A	32-bit data is written to external memory.
16	1	N/A	16-bit data received is zero filled. For transmitted data only 16-bit of the 32-bit data word is written to external memory.
8	0	N/A	8-bit data received is zero filled. For transmitted data only the 8-bit LSB part of the 32-bit data word is written to external memory.
32	0	0	32-bit data is written to external memory.
16	0	0	16-bit received data is packed to 32-bit data and transmitted 32-bit data is unpacked to 2 16-bit data. First 16-bit word read/written occupies the least significant position in the 32-bit packed word.
8	0	0	8-bit received data is packed to 32-bit data and transmitted 32-bit data is unpacked to 4 8-bit data. First 8-bit word read/written occupies the least significant position in the 32-bit packed word.
16	0	1	16-bit received data is packed to 32-bit data and transmitted 32-bit data is unpacked to 2 16-bit data. First 16-bit word read/written occupies the most significant position in the 32-bit packed word.
8	1	1	8-bit received data is packed to 32-bit data and transmitted 32-bit data is unpacked to 4 8-bit data. First 8-bit word read/written occupies the most significant position in the 32-bit packed word.

External Access Extension

The AMI controller has an **ACK** pin which can be used for external access extension. When **ACK** is enabled, the wait state value should be set to indicate when the processor can sample **ACK** after the $\overline{RD}/\overline{WR}$ edge goes low (refer to [Figure 3-2](#) and [Figure 3-3](#)). If **ACK** is not enabled, the minimum value for **WS** is 2 (a wait state value of 0 corresponds to 32 wait cycles). If **ACK** is enabled, the minimum allowed value for **WS** is 1.

When `ACK` is enabled (`ACKEN = 1`), the processor samples the `ACK` signal after two wait states plus the expiration of the wait state count programmed in the `AMICTLx` register. It is imperative that the `WS` value is initialized when the acknowledge enable bit (`ACKEN`) is set.

Predictive Reads

The AMI controller allows two types of read access:

- predictive reads (default)
- non predictive reads

Predictive read (`PREDIS` bit = 0) reduces the time delay between two reads. The predictive address is generated and compared with the actual address. If they do not match, then that read data is ignored. Every last read access is therefore a duplication of the 2nd to last read with the same address. Note that this redundant read does not update the memory location.

In contrast, when no predictive read (`PREDIS` bit = 1) is used, the delay between two reads increases. Note that both DMA and the processor core have predictive read capability. Further note that the `PREDIS` bit should not be changed when the AMI is performing an access. Predictive reads reduce peripheral performance.

If an access to an external FIFO is required at maximum speed, programs can also clear `PREDIS` (=0). The last access before a non AMI access should be a dummy AMI write access. This ensures that the last predictive read is omitted.



The `PREDIS` bit (bit 21) is a global bit that when set in any of the `AMICTLx` registers provides access to all memory banks.

SDRAM Controller

The ADSP-21367/8/9 and ADSP-2137x SHARC processors support a glueless interface with any of the standard SDRAMs. The following sections provide detail about this interface.

Features

The SDRAM controller can support up to 254M words of SDRAM in four banks. Bank 0 can accommodate up to 62M words, and banks 1, 2, and 3 can accommodate up to 64M words each. The interface has the following additional features.

- I/O width 16-bit or 32-bits, I/O supply 3.3 V.
- Types of 32, 64, 128, 256, and 512M bit with I/O of x4, x8, x16 and x32.
- Page sizes of 128, 256, 512, 1k, 2k words.
- No-burst mode (BL = 1) with sequential burst type.
- Optional full page burst (ADSP-2137x only).
- Open page policy—any open page is closed only if a new access in another page of the same bank occurs.
- Supports multibank operation within the SDRAM (ADSP-2137x only).
- Uses a programmable refresh counter to coordinate between varying clock frequencies and the SDRAM's required refresh rate.
- Provides multiple timing options to support additional buffers between the processor and SDRAM.
- Allows independent auto-refresh while the asynchronous memory interface (AMI) has control of the external port.

- Supports self-refresh mode for power savings.
- Supports instruction fetch (ADSP-2137x only).

Table 3-5. SDRAM Overview Comparison by Product

Feature	ADSP-2136x	ADSP-2137x
Force LMR	No	Yes
Burst length	1	1 or Full Page
Multi-bank support	No	Yes ($\overline{MS0}/\overline{MS1}$)
External Instruction Fetch	No	Yes

Functional Description

The AMI normally generates an external memory address, which then asserts the corresponding \overline{CS} select on the SDRAM, along with \overline{RD} and \overline{WR} strobes. However these control signals are not used by the SDRAM controller. The internal strobes are used to generate pulsed commands (\overline{MSx} , \overline{SDCKE} , \overline{SDRAS} , \overline{SDCAS} , \overline{SDWE}) within a truth table [Table 3-6](#). The memory access to SDRAM is based by mapping ADDR_{27-0} causing an internal memory select to SDRAM space.

The configuration is programmed in the SDCTL register. The SDRAM controller can hold off the processor core or DMA controller with an internally connected acknowledge signal, as controlled by refresh, or page miss latency overhead.

A programmable refresh counter is provided which generates background auto-refresh cycles at the required refresh rate based on the clock frequency used. The refresh counter period is specified with the RDIV field in the SDRAM refresh rate control register (“[Refresh Rate Control Register \(SDRRC\)](#)” on page A-30).

SDRAM Controller

The internal 32-bit non-multiplexed address is multiplexed into:

- SDRAM column address
- SDRAM row address
- Internal SDRAM bank address

The lowest bits are mapped into the column address, next bits are mapped into the row address, and the final two bits are mapped into the internal bank address. This mapping is based on the $SDCAW$ and $SDRAW$ values programmed into the SDRAM control register.

The SDRAM controller uses no burst mode ($BL = 1$) for read and write operations. This requires the controller to post every read or write address on the bus as for non-sequential reads or writes, but does not cause any performance degradation. For ADSP-2137x processors, the default burst is full page ($BL = 0$). However, for full page burst, every single access is immediately interrupted by another access resulting in no burst mode.

For read commands, there is a latency from the start of the read command to the availability of data from the SDRAM, equal to the CAS latency. This latency is always present for any single read transfer. Subsequent reads do not have latency.

For more information on commands used by the SDRAM controller, see [“SDRAM Commands” on page 3-18](#).

SDRAM Commands

This section provides a description of each of the commands that the controller uses to manage the SDRAM interface. These commands are handled automatically by the controller. A summary of the various commands used by the on-chip controller for the SDRAM interface follows and is shown in [Table 3-6 on page 3-26](#).

-  The SDRAM controller requires a dummy access to the SDRAM space to trigger the 3 commands for power-up (PRE, MRS, REF).
- Load mode register—initializes the SDRAM operation parameters during the power-up sequence.
 - Single precharge—closes a specific internal bank depending on user code (ADSP-2137x processors only).
 - Precharge all—closes all internal banks, preceding any auto-refresh command.
 - Activate—activates a page in the required internal SDRAM bank.
 - Read/write
 - Auto-refresh—causes the SDRAM to execute an internal CAS before RAS refresh.
 - Self-refresh entry—places the SDRAM in self-refresh mode, in which the SDRAM powers down and controls its refresh operations internally.
 - Self-refresh exit—exits from self-refresh mode by expecting auto-refresh commands from the controller.
 - NOP/command inhibit—no operation used to insert wait states for activate and precharge cycles.
 - Burst Stop command—used to interrupt any full page burst operation (ADSP-2137x processors only).

Load Mode Register

This command initializes SDRAM operation parameters. It is a part of the SDRAM power-up sequence. Load mode register uses the address bus of the SDRAM as data input. The power-up sequence is prepared by writing 1 to the SDPSS bit in the SDCTL register. The exact order of the power-up sequence is determined by the SDPM bit of the SDCTL register.

SDRAM Controller

The load mode register command initializes the following parameters.

- Burst length = 1, bits 2–0, always zero
- Optional burst length = full page, bits 2–0, all ones (ADSP-2137x processors only)
- Wrap type = sequential, bit 3, always zero
- Ltmode = latency mode (CAS latency), bits 6–4, programmable in the SDCTL register
- Bits 14–7, always zero

While executing the load mode register command, the unused address pins are set to zero. During the first SDCLK cycle following load mode register, the controller issues only NOP commands to satisfy the t_{MRD} specification.



The SDRAM controller does not support extended mode register set.

Single Bank Activation

The bank activation command is required for first access to any internal bank in SDRAM. Any subsequent access to the same internal bank but different row is preceded by a precharge and activation command to that bank.

However, if an access to another bank occurs, the controller closes the current page open and issues another bank activate command before executing the read or write command to that bank. With this method, called *single bank* operation, only one page can be open at a time.

Multibank Activation (ADSP-2137x Processors)

Unlike this command for the ADSP-21367/8/9 processors, if any other access to another bank occurs, the controller leaves the current page open and issues a bank activate command before executing the read or write command to that bank. With this method, called multibank operation, one page per bank can be open at a time, which results in a maximum of four pages. [For more information, see “Multibank Access \(ADSP-2137x Processors\)” on page 3-34.](#)

 Multibank activation is only supported for the external banks 0 and 1.

Single Precharge (ADSP-2137x Processors)

For a page miss during reads or writes in any specific internal SDRAM bank, the SDRAM controller uses the single precharge command to close that bank. All other internal banks are untouched.

 This command is only supported for the external banks 0 and 1.

Precharge All

The precharge all command is given to precharge all internal banks at the same time before executing an auto-refresh. All open banks are automatically closed. This is possible since the controller uses a separate SDA10 pin which is asserted high during this command. This command proceeds the auto-refresh command. Also, for single bank operation, this command is used to close any open bank after a page miss detection.

Read/Write

This command is executed if the next read/write access is in the present active page. During the read command, the SDRAM latches the column address. The delay between activate and read commands is determined by the t_{RCD} parameter. Data is available from the SDRAM after the CAS latency has been met.

SDRAM Controller

In the write command, the SDRAM latches the column address. The write data is also valid in the same cycle. The delay between activate and write commands is determined by the t_{RCD} parameter.

The controller does not use the auto-precharge function of SDRAMs, which is enabled by asserting SDA_{10} high during a read or write command.

Figure 3-4 and Figure 3-5 show the SDRAM write and read timing of the ADSP-21367/8/9 processors respectively. Figure 3-6 and Figure 3-7 show the SDRAM write and read timing for the ADSP-2137x processors.

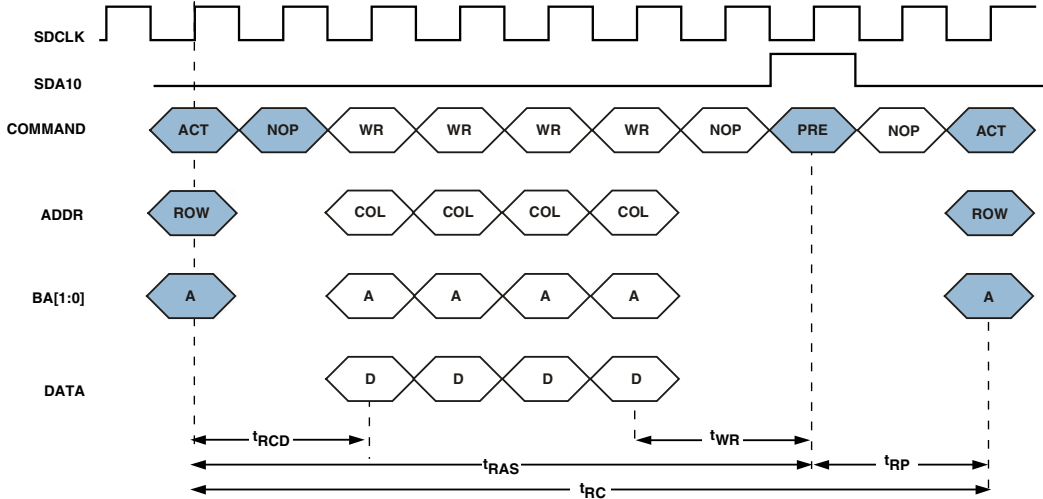

Figure 3-4. Write Timing Diagram ADSP-21367/8/9

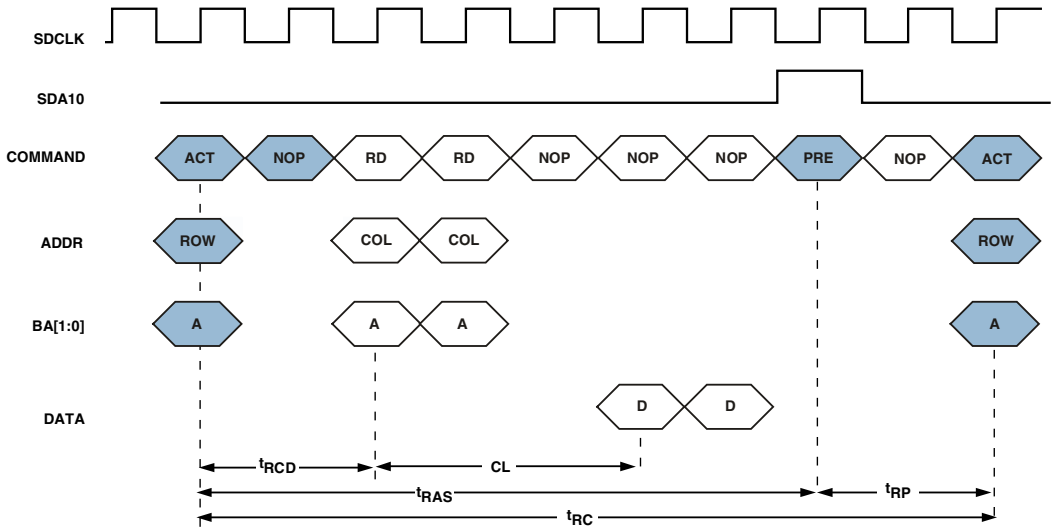

Figure 3-5. Read Timing Diagram ADSP-21367/8/9

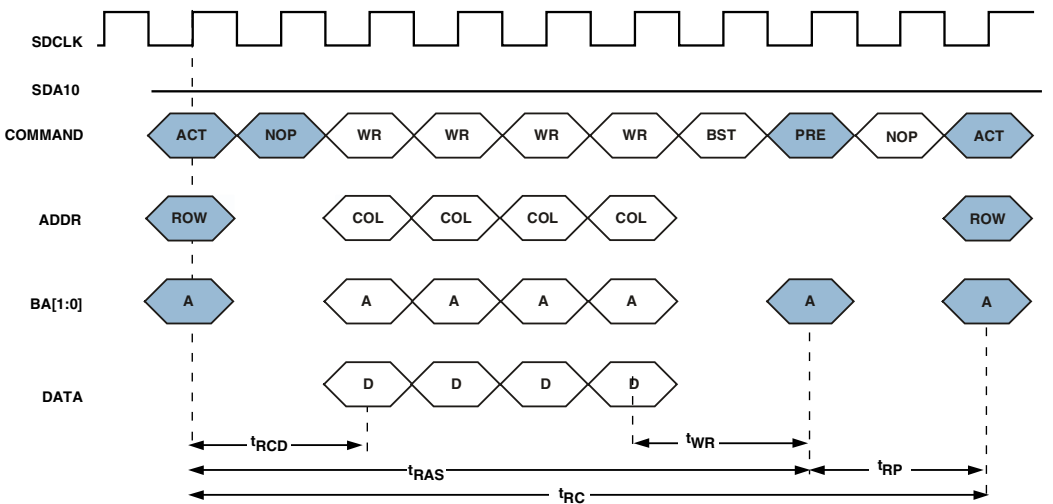

Figure 3-6. Write Timing Diagram (ADSP-2137x, Full Page Burst)

SDRAM Controller

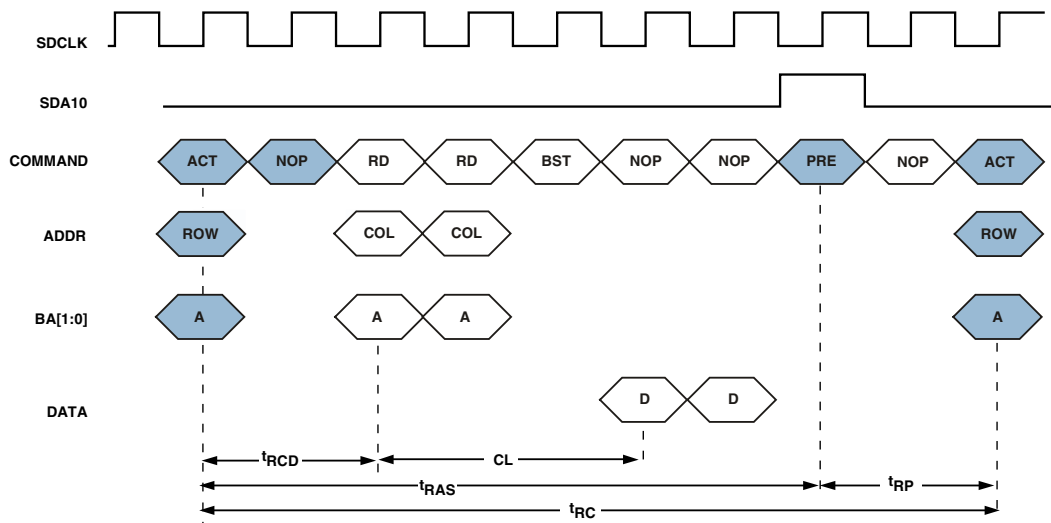

Figure 3-7. Read Timing Diagram (ADSP-2137x, Full Page Burst)

Read/Write Full Page Burst (ADSP-2137x Processors)

If full page burst is selected in the `SDCTL` register, the controller configures the SDRAM during the `MRS` command in full page burst mode. However, it does not use the full page burst protocol (post only the start address on the bus and `NOPS` for continue burst in case for sequential addresses). Instead, for every access it issues an address (as for burst length = 1). Note this mode is required for SDRAMs which don't support `BL = 1`.

Burst Stop (ADSP-2137x Processors)

If full page burst (`SDNOBSTOP` bit in the `SDCTL` register) is selected, the controller posts a burst stop command after every read/write access end. This is required to ensure that the internal SDRAM burst counter does not continue and drive/latch invalid data. If an interrupt is required (a system interrupt or auto-refresh command for example), the controller also issues a burst stop command. Note that by executing a burst stop command, the specific page remains open.

Auto-Refresh

The SDRAM internally increments the refresh address counter and causes a CAS before RAS (CBR) refresh to occur internally for that address when the auto-refresh command is given. The controller generates an auto-refresh command after the refresh counter times out. The $RDIV$ value in the SDRAM refresh rate control register (SDRRC) must be set so that all addresses are refreshed within the t_{REF} period specified in the SDRAM timing specifications.

Before executing the auto-refresh command, the controller executes a pre-charge all command to all external banks. The next activate command is not given until the t_{RFC} specification ($t_{RFC} = t_{RAS} + t_{RP}$) is met.

Auto-refresh commands are also issued by the controller as part of the power-up sequence and after exiting self-refresh mode.

No Operation/Command Inhibit

The no operation (NOP) command to the SDRAM has no effect on operations currently in progress. The command inhibit command is the same as a NOP command; however, the SDRAM is not chip-selected. When the controller is actively accessing the SDRAM but needs to insert additional commands with no effect, the NOP command is given. When the controller is not accessing any SDRAM external banks, the command inhibit command is given.

Command Truth Table

Table 3-6 provides the bit states of the SDRAM for specific SDRAM commands. Note that an X means do not care.

SDRAM Controller

Table 3-6. SDRAM Pin States During Controller Commands

Command	SDCKE (n-1)	SDCKE (n)	MS3-0	SDRAS	SDCAS	SDWE	SDA10	Addresses
Mode register set	1	1	0	0	0	0	Opcode	Opcode
Activate	1	1	0	0	1	0	Valid	Valid
Read	1	1	0	1	0	1	0	Valid
Single Precharge	1	1	0	0	1	0	0	Valid
Precharge all	1	1	0	0	1	0	1	X
Write	1	1	0	1	0	0	0	Valid
Auto-refresh	1	1	0	0	0	1	X	X
Self-refresh entry	1	0	0	0	0	1	X	X
Self-refresh	0	0	X	X	X	X	X	X
Self-refresh exit	0	1	1	X	X	X	X	X
Burst Stop	1	1	0	1	1	0	X	X
Nop	1	1	0	1	1	1	X	X
Inhibit	1	1	1	X	X	X	X	X

Address Mapping

The address that is seen from the processor core and DMA controller is referred to as internal address space IA31-0 in the following sections. The internal address is divided into three parts to generate the SDRAM row, column, and bank addresses as shown in [Figure 3-8](#).

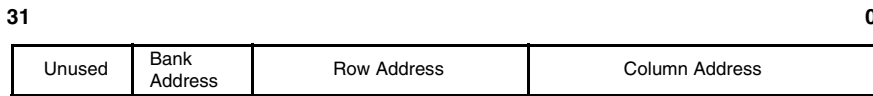



Figure 3-8. Core Address Mapping to Bank, Row, and Column Addresses

To access SDRAM, the controller multiplexes the internal 32-bit, non-multiplexed address into a row and column address. The row and column address mappings for 32-bit and 16-bit addresses are shown in [Table 3-7 on page 3-28](#) through [Table 3-10 on page 3-31](#). The row and column addresses are multiplexed to pins A14–A0 of the processor. The SDRAM address pin A10 is connected to the processor's SDA10 pin. The controller's bank address pins BA0 and BA1 are connected to the processor's A17 and A18 pins.

 For two-banked SDRAMs, connect BA with A17.

External Addressing Modes

The ADSP-21367/8/9 and ADSP-2137x processors have the ability to use logical addressing when an external memory smaller than 32 bits is used. When logical addresses are used, multiple external addresses seen by the memory correspond to a single internal address, depending on the width of the memory being accessed by the SDRAM controller.

 The mapping of the addresses depends on the row address width (SDRAW), column address width (SDCAW), and the X16DE bit setting.

32-Bit Address Mapping

In the following sections and in [Table 3-7](#) through [Table 3-10](#), the mapping of internal addresses to the external addresses is discussed. The mapping of the addresses depends on the row address width (SDRAW), column address width (SDCAW), and the X16DE bit setting.

SDRAM Controller

In [Table 3-7](#), $X16DE = 0$, $SDRAW2-0 = 100$ (12 bits), and $SDCAW1-0 = 10$ (10 bits).

Table 3-7. 32-Bit Column, Row, and Bank Address Mapping (1K Words)

Pin	Column Address	Row Address	Bank Address	Pins of SDRAM
A[18]			IA[23]	BA[1]
A[17]			IA[22]	BA[0]
A[13]				A[12]
A[12]		IA[21]		A[11]
SDA10		IA[20]		A[10]
A[10]	IA[9]	IA[19]		A[9]
A[9]	IA[8]	IA[18]		A[8]
A[8]	IA[7]	IA[17]		A[7]
A[7]	IA[6]	IA[16]		A[6]
A[6]	IA[5]	IA[15]		A[5]
A[5]	IA[4]	IA[14]		A[4]
A[4]	IA[3]	IA[13]		A[3]
A[3]	IA[2]	IA[12]		A[2]
A[2]	IA[1]	IA[11]		A[1]
A[1]	IA[0]	IA[10]		A[0]
A[0]	Not USED for 32-bit SDRAMs			

In [Table 3-8](#), $X16DE = 0$, $SDRAW2-0 = 100$ (12 bits), and $SDCAW1-0 = 11$ (11 bits).

Table 3-8. 32-Bit Column, Row and Bank Address Mapping (2K Words)

Pin	Column Address	Row Address	Bank Address	Pins of SDRAM
A[18]			IA[24]	BA[1]
A[17]			IA[23]	BA[0]
A[13]				A[12]
A[12]	IA[10]	IA[22]		A[11]
SDA10		IA[21]		A[10]
A[10]	IA[9]	IA[20]		A[9]
A[9]	IA[8]	IA[19]		A[8]
A[8]	IA[7]	IA[18]		A[7]
A[7]	IA[6]	IA[17]		A[6]
A[6]	IA[5]	IA[16]		A[5]
A[5]	IA[4]	IA[15]		A[4]
A[4]	IA[3]	IA[14]		A[3]
A[3]	IA[2]	IA[13]		A[2]
A[2]	IA[1]	IA[12]		A[1]
A[1]	IA[0]	IA[11]		A[0]
A[0]	Not USED for 32-bit SDRAMs			

SDRAM Controller

16-Bit Address Mapping

Even if the external data width is 16 bits, the processor supports only 32-bit data accesses. If X_{16DE} is enabled (=1) the controller performs two 16-bit accesses to get and place 32-bit data. The controller takes the IA address and appends one extra bit to the LSB to generate the address externally.

For example, if the processor core requests address 0x200–0000 for a 32-bit access, the controller performs two 16-bit accesses at 0x000–0000 and 0x000–0001, using $\overline{MS0}$ to get one 32-bit data word. The column and row addresses seen by 16-bit SDRAMs is shown in [Table 3-9](#) where $X_{16DE} = 1$, $SDRAW2-0 = 100$ (12 bits), and $SDCAW1-0 = 10$ (10 bits) and [Table 3-10](#) where $X_{16DE} = 1$, $SDRAW2-0 = 100$ (12 bits), and $SDCAW1-0 = 11$ (11 bits).

Table 3-9. 16-Bit Row and Column Address Mapping (1K Words)

Pin	Column Address	Row Address	Bank Address	Pins of SDRAM
A[18]			IA[22]	BA[1]
A[17]			IA[21]	BA[0]
A[13]				
A[12]				A[12]
A[11]		IA[20]		A[11]
SDA10		IA[19]		A[10]
A[9]	IA[8]	IA[18]		A[9]
A[8]	IA[7]	IA[17]		A[8]
A[7]	IA[6]	IA[16]		A[7]
A[6]	IA[5]	IA[15]		A[6]
A[5]	IA[4]	IA[14]		A[5]
A[4]	IA[3]	IA[13]		A[4]

Table 3-9. 16-Bit Row and Column Address Mapping (1K Words) (Cont'd)

Pin	Column Address	Row Address	Bank Address	Pins of SDRAM
A[3]	IA[2]	IA[12]		A[3]
A[2]	IA[1]	IA[11]		A[2]
A[1]	IA[0]	IA[10]		A[1]
A[0]	1/0	IA[9]		A[0]

Table 3-10. 16-Bit Row and Column Address Mapping (2K Words)

Pin	Column Address	Row Address	Bank Address	Pins of SDRAM
A[18]			IA[23]	BA[1]
A[17]			IA[22]	BA[0]
A[13]				
A[12]				A[12]
A[11]	IA[9]	IA[21]		A[11]
SDA10		IA[20]		A[10]
A[9]	IA[8]	IA[19]		A[9]
A[8]	IA[7]	IA[18]		A[8]
A[7]	IA[6]	IA[17]		A[7]
A[6]	IA[5]	IA[16]		A[6]
A[5]	IA[4]	IA[15]		A[5]
A[4]	IA[3]	IA[14]		A[4]
A[3]	IA[2]	IA[13]		A[3]
A[2]	IA[1]	IA[12]		A[2]
A[1]	IA[0]	IA[11]		A[1]
A[0]	1/0	IA[10]		A[0]

Refresh Rate Control

The SDRAM refresh rate control register provides a flexible mechanism for specifying auto-refresh timing. The controller provides a programmable refresh counter which has a period based on the value programmed into the lower 12 bits of this register. This coordinates the supplied clock rate with the SDRAM device's required refresh rate.

The delay (in number of $SDCLK$ cycles) between consecutive refresh counter time-outs must be written to the $RDIV$ field. A refresh counter time-out triggers an auto-refresh command to the external SDRAM bank. Programs should write the $RDIV$ value to the $SDRRC$ register before the SDRAM power-up sequence is triggered. Change this value only when the controller is idle as indicated in the $SDSTAT$ register.

To calculate the value to write to the $SDRRC$ register, use the following equation.

$$RDIV \leq \left(\frac{f_{SDCLK} \times t_{REF}}{NRA} \right) - (t_{RAS} + t_{RP})$$

Where:

- f_{SDCLK} = $SDCLK$ frequency (SDRAM clock frequency)
- t_{REF} = SDRAM refresh period
- NRA = Number of row addresses in SDRAM (refresh cycles to refresh whole SDRAM)
- t_{RAS} = Active to precharge time ($SDTRAS$ bits in the SDRAM memory control register) in number of clock cycles
- t_{RP} = RAS to precharge time (in the SDRAM memory control register) in number of clock cycles

This equation calculates the number of clock cycles between required refreshes and subtracts the required delay between bank activate commands to the same bank ($t_{RC} = t_{RAS} + t_{RP}$). The t_{RC} value is subtracted, so that in the case where a refresh time-out occurs while an SDRAM cycle is active, the SDRAM refresh rate specification is guaranteed to be met. The result from the equation is always rounded down to an integer. Below is an example of the calculation of $RDIV$ for a typical SDRAM in a system with a 133 MHz SDRAM clock.

- $f_{SDCLK} = 133 \text{ MHz}$
- $t_{REF} = 64 \text{ ms}$
- $NRA = 8192 \text{ row addresses}$
- $t_{RAS} = 6$
- $t_{RP} = 3$

$$RDIV = \left(\frac{133 \times (10^6) \times 64 \times (10^{-3})}{8192} \right) - (6 + 3) = 1030$$

This means $RDIV$ is 0x406 (hex) and the SDRAM refresh rate control register is written with 0x406.

The $RDIV$ value must be programmed to a nonzero value if the SDRAM controller is enabled. When $RDIV = 0$, operation of the SDRAM controller is not supported and can produce undesirable behavior. Values for $RDIV$ can range from 0x001 to 0xFFF.



Notice that some SDRAM vendors use separate timing specifications for the row active time (t_{RC}) and row refresh time (t_{RFC}). The controller does ignore the t_{RFC} spec. For auto-refresh, it uses the equation $t_{RC} = t_{RAS} + t_{RP}$. However since both timing

SDRAM Controller

specifications must meet (especially for extended temperature range) the modification of t_{RAS} specification resolves the timing equation without performance degradation ($t_{RFC} = t_{RAS} + t_{RP}$).

Internal SDRAM Bank Access

The following sections describe the different scenarios for SDRAM bank access.

Single Bank Access

The SDRAM controller keeps only one page open at a time, however, driving four external memory selects populated with SDRAM, the effective page size is increased up to four pages.

Multibank Access (ADSP-2137x Processors)

The ADSP-2137x processors are capable of supporting multibank operation, thus taking advantage of the SDRAM architecture.

 Operations using single versus multibank accesses depend only on the address to be posted to the device, these are NOT operation modes.

Any first access to SDRAM bank (A) forces an activate command before a read or write command. However, if any new access falls into the address space of the other banks (B, C, or D) the controller leaves bank (A) open and activates any of the other banks (B, C, or D). Bank (A) to bank (B) active time is controlled by $t_{RRD} = t_{RCD} + 1$. This scenario is repeated until all four banks (A–D) are opened and results in an effective page size of up to four pages.

This is because the absence of latency allows switching between these open pages (as compared to one page in only one bank at a time). Any access to any closed page in any opened bank (A–D) forces a precharge command only to that bank. If, for example, two external port DMA channels are pointing to the same internal SDRAM bank, this always forces precharge

and activation cycles to switch between the different pages. However, if the two external port DMA channels are pointing to different internal SDRAM banks, there is no additional overhead. See [Figure 3-9](#).

Furthermore the controller supports four external memory selects containing each SDRAM. However only the external banks 0 and 1 ($\overline{MS0}$ and $\overline{MS1}$) provide multibank support, so the maximum number of open pages is $2 \times 4 + 2 \times 1 = 10$ pages.

i Multibank access reduces precharge and activation cycles by mapping opcode/data among different internal SDRAM banks driven by the A18–17 pins and external memory selects (\overline{MSx}).

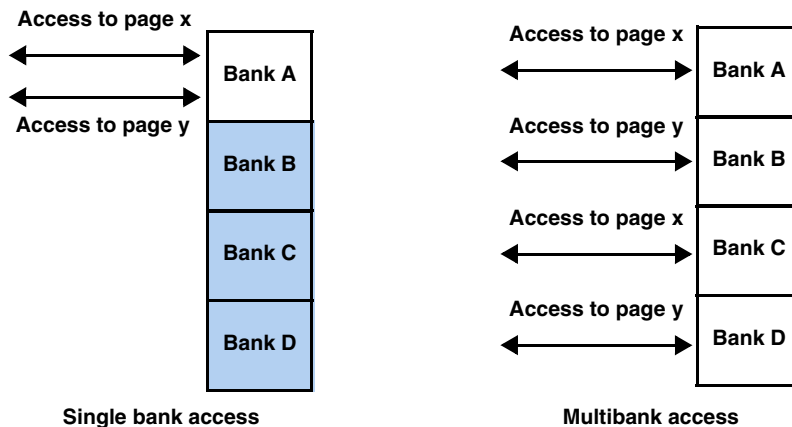

Figure 3-9. Single Versus Multibank Access

For example a populated SDRAM of $2M \times 32 \times 4$ with 512 words page size connected to external bank 0 has a logical mapping:

```
0x200000 logical start address int bankA
0x2001FF logical end address int bankA

0x400000 logical start address int bankB
0x4001FF logical end address int bankB
```

SDRAM Controller

```
0x600000 logical start address int bankC
0x6001FF logical end address int bankC

0x800000 logical start address int bankD
0x8001FF logical end address int bankD
```

Multi Bank Operation with Data Packing (ADSP-2137x)

If there is no data packing enabled ($X16DE$ bit =0), a logical addresses correspond to a physical address. However if this bit is set, a logical address correspond to 2 physical addresses. Consequently a physical address for example of 512 x 16 page size translates into a logical address of 256 x 16 words to satisfy the packing. According to this all row addresses are shifted by 2.

For example a populated SDRAM of 2M x 16 x 4 with 512 words page size connected to external bank 0 has a logical mapping:

```
0x200000 logical start address int bankA
0x2000FF logical end address int bankA

0x300000 logical start address int bankB
0x3000FF logical end address int bankB

0x400000 logical start address int bankC
0x4000FF logical end address int bankC

0x500000 logical start address int bankD
0x5000FF logical end address int bankD
```

Timing Parameters

The controller requires many timing settings in order to correctly access the SDRAM devices. Those that are user configurable can be found in [“SDRAM Registers” on page A-25](#).

Fixed Timing Parameters

The timing specifications below are fixed by the controller.

- t_{MRD} (mode register delay). Required delay time to complete the mode register write. This parameter is fixed to 2 cycles.
- t_{RRD} (row active A to row active B delay). Required delay between two different SDRAM banks. This parameter is fixed to $t_{RCD} + 1$ cycle.
- t_{RC} (row access cycle). Required delay time to open and close a single row. This parameter is fixed to $t_{RC} = t_{RAS} + t_{RP}$ cycles.
- t_{RFC} (row refresh cycle). Required delay time to refresh a single row. This parameter is fixed to $t_{RFC} = t_{RC}$ cycles.
- t_{XSR} (exit self-refresh mode). Required delay to exit the self-refresh mode. This parameter is fixed to $t_{XSR} = t_{RC}$ cycles.

Data Mask (DQM)

Since the SHARC processors do not support byte addressing, there is no need to mask data during partial writes (for example, higher or lower byte on a 16-bit wide SDRAM).



All SDRAM DQM pins must be tied low.

Resetting the Controller

Like any other peripheral, the SDRAM controller can be reset by a hard or a soft reset. A hard reset puts the PLL in bypass mode where the SDRAM clock runs at a lower frequency.

SDRAM Controller

A soft reset also causes data loss, and programs need to re-initialize SDRAM before it can be used again.

 Running reset ($\overline{\text{RESETOUT}}$ pin as an input) does not reset the SDRAM controller.

Operating Modes

The following sections provide on the operating modes of the SDRAM interface.

Parallel Connection of SDRAMs

To specify a SDRAM system, multiple possibilities are given based on the different memory sizes. For a 32-bit I/O capability, the following can be configured.

- 1 x 32-bit/page 256 words
- 2 x 16-bit/page 512 words
- 4 x 8-bit/page 1k words
- 8 x 4-bit/page 2k words

The SDRAM's page size is used to determine the system you select. All four systems have the same external bank size, but different page sizes. Note that larger page sizes, allow higher performance but larger page sizes require more complex hardware layouts.

 Even if connecting SDRAMs in parallel, the controller always considers the cluster as one external SDRAM bank because all address and control lines feed the parallel parts as shown in [Figure 3-10](#).

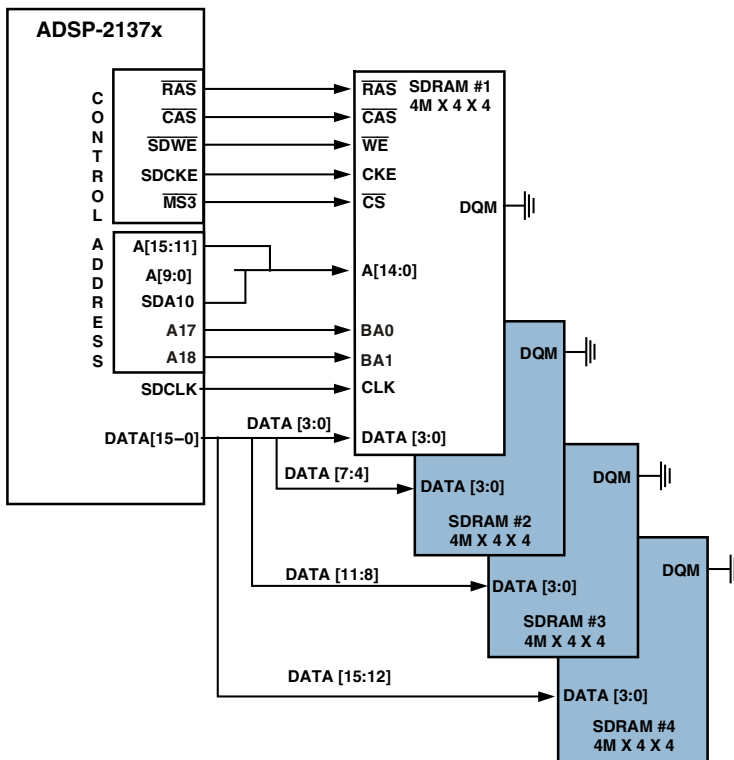

Figure 3-10. Single Processor System With Multiple SDRAM Devices

Buffering Controller for Multiple SDRAMs

If using multiples SDRAMs or modules, the capacitive load will exceed the controller's output drive strength. In order to bypass this problem an external latch can be used for decoupling by setting the SDBUF (bit 23). This adds a cycle of data buffering to read and write accesses. An example single processor system is shown in [Figure 3-11 on page 3-40](#).

SDRAM Controller

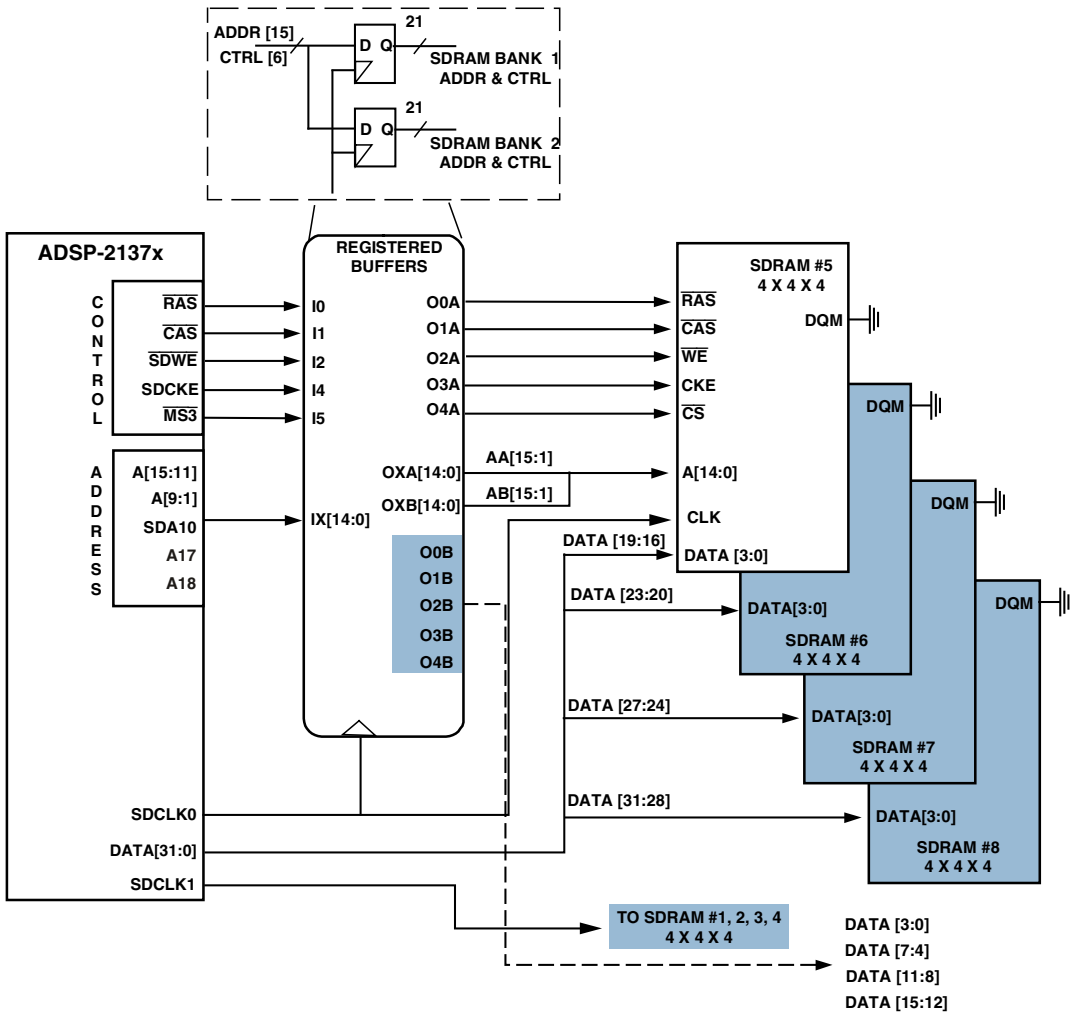

Figure 3-11. Uniprocessor System With Multiple Buffered SDRAM Devices

SDRAM Read Optimization

To achieve better performance, read addresses can be provided in a predictive manner to the SDRAM memory. This is done by setting (=1) the `SDROPT` bit (bit 16) and correctly configuring the `SDMODIFY` bits (bits 20-17) in the `SDRRC` register according to the core's DAG modifier or the DMA's modify parameter register.

The predictive address given to the memory depends on the `SDMODIFY` bit values. For example, if the DAG modifier = 2, the `SDMODIFY` value should also be 2, in which case the address + 2 is the predictive value provided to the SDRAM address pins. Programs may choose to determine whether read optimization is used or not. If read optimization is disabled, then each read takes 7 cycles for a CAS latency of 3, even for sequential reads.

With read optimization enabled, 32 sequential reads, with offsets ranging from 0 to 15, take only 37 `SDCLK` cycles. Read optimization should not be enabled while reading at the external bank boundaries. For example, if `SDMODIFY` = 1, then 32 locations in the boundary of the external banks should not be used. These locations can be used without optimization enabled. If `SDMODIFY` = 2, then 64 locations cannot be used at the boundaries of the external bank (if it is fully populated).

It is advisable to use read optimization for core and DMA, with a constant modifier to achieve better performance. With multiple channels running with ping-pong accesses, use arbitration freezing to get better throughput.

 By default, the read optimization is enabled (`SDROPT` = 1) with a modifier of 1 (`SDMODIFY` = 1). Read optimization assumes that the SDRAM pointer has a constant modifier. For non-sequential accesses, the optimization should be turned off.

SDRAM Controller

Core Accesses

Any break of sequential reads of 32 accesses can cause a throughput loss due to a maximum of eight extra reads in 32-bit memories or four extra reads (eight 16-bit reads). [Listing 3-1](#) shows how to achieve maximum throughput using core accesses. Any cycle between consecutive reads to an SDRAM address results in non-sequential reads.

Listing 3-1. Maximum Throughput Using Sequential Reads

```
ustat1=dm(SDCTL);
bit set ustat1 SDRPT|SDMODIFY1;
dm(SDCTL)=ustat1;
nop;
IO = sdram_addr;
MO = 1;
Lcntr = 1024, do(PC,1) until lce;
RO = RO + R1, RO = dm (IO, MO);
```

The example shows read optimization can be used efficiently using core accesses. All reads are on the same page and it takes 1184 cycles to perform 1024 reads.

Without read optimization, 1024 reads use 6144 processor cycles if all of the reads are on the same page. With read optimization ([Listing 3-2](#)), 1024 reads take 7168 cycles, due to the breaking of sequential reads.

Listing 3-2. Interrupted Reads With Read Optimization

```
ustat1=dm(SDCTL);
bit set ustat1 SDRPT|SDMODIFY2;
dm(SDCTL)=ustat1;
nop;
IO = sdram_addr;
MO = 2;
```

```

Lcntr = 1024, do(PC,2) until lce;
R0 = R0 + R1, R0 = dm (I0, M0);
NOP;

```

DMA Access

[Listing 3-3](#) shows an example of external port DMA using read optimization.

Listing 3-3. External Port DMA With Read Optimization

```

ustat1=dm(SDCTL);
bit set ustat1 SDRPT|SDMODIFY2;
dm(SDCTL)=ustat1;
nop;

r0=DFLSH;
dm(DMAC1)=r0;
r0=intmem;    dm(IIEP1)=r0;
r0=2;        dm(IMEP1)=r0;
r0=N;        dm(ICEP1)=r0;
r0=2;        dm(EMEP1)=r0;
r0=extmem;   dm(EIEP1)=r0;
r0=DEN;
dm(DMAC1)=r0;

```

Notes on Read Optimization

The core and the DMA engine take advantage of the major improvements during reads using read optimization. However, in situations where both the core and DMA need to read from different internal memory banks with different modifiers at the same time, programs need to choose whether or not to use optimization. Note that from a throughput perspective, external port arbitration also is a factor. A good rule is that the requester with the higher priority should have the same modifier as `SDMODIFY`. In other words, if DMA has a higher priority over the core, then the DMA modifier should match the `SDMODIFY` setting.

Self-Refresh Mode

This mode causes refresh operations to be performed internally by the SDRAM, without any external control. This means that the controller does not generate any auto-refresh cycles while the SDRAM is in self-refresh mode.

Self-refresh entry—Self-refresh mode is enabled by writing a 1 to the `SDSRF` bit of the SDRAM memory control register (`SDCTL`). This de-asserts the `SDCKE` pin and puts the SDRAM in self-refresh mode if no access is currently underway. The SDRAM remains in self-refresh mode for at least t_{RAS} and until an internal access (read/write) to SDRAM space occurs.

Self-refresh exit—When any SDRAM access occurs, the controller asserts `SDCKE` high which causes the SDRAM to exit from self-refresh mode. The controller waits to meet the t_{XSR} specification ($t_{XSR} = t_{RAS} + t_{RP}$) and then issues an auto-refresh command. After the auto-refresh command, the controller waits for the t_{RFC} specification ($t_{RFC} = t_{RAS} + t_{RP}$) to be met before executing the activate command for the transfer that caused the SDRAM to exit self-refresh mode. Therefore, the latency from when a transfer is received by the controller while in self-refresh mode, until the activate command occurs for that transfer, is $2 \times (t_{RC} + t_{RP})$ cycles.

System clock during self-refresh mode. Note that the `SDCLK` is not disabled by the SDRAM controller during self-refresh mode. However, software may disable the clocks by clearing the `DSDCTL` bit in the `SDCTL` register. Programs should ensure that all applicable clock timing specifications are met before the transfer to SDRAM address space (which causes the controller to exit the self-refresh mode). If a transfer occurs to SDRAM address space when the `DSDCTL` bit is cleared, an internal bus error is generated, and the access does not occur externally, leaving the SDRAM in self-refresh mode.

The following steps are required when using self-refresh mode.

1. Set the `SDSRF` bit to enter self-refresh mode.
2. Poll the `SDSRA` bit in the SDRAM status register (`SDSTAT`) to determine if the SDRAM has already entered self-refresh mode.
3. Optionally: set the `DSDCTL` bit to freeze `SDCLK`.
4. Optionally: clear the `DSDCTL` bit to re-enable `SDCLK`.
5. SDRAM access occurs the SDRAM exits from self-refresh mode.

 The minimum time between a subsequent self-refresh entry and exit command is the t_{RAS} cycle. If a self-refresh request is issued during any external port DMA, the controller grants the request with the t_{RAS} cycle and continues DMA operation afterwards.

Forcing SDRAM Commands

The SDRAM controller has specific bits that can be used to aid in debug and in specific system solutions.

Force Precharge All

Whenever an auto-refresh or a mode register set command is issued, the internal banks are required to be in idle state. Setting bit 21 (=1) forces a precharge all command to accomplish this. If the precharge all command is not issued, the auto-refresh and mode register set commands can be illegal depending on the current state.

Note that it is a good practice always to perform a force precharge all command before a forced refresh/mode register command.

Shared Memory Interface (ADSP-21368)

Force Load Mode Register (ADSP-2137x Only)

Programs can use the Force LMR command by setting bit 22 (=1) in the `SDCTL` register. This command is preceded by a precharge all (if banks not idle) followed by a mode register write.

The Force LMR bit allows changes to the `MODE` register based settings during runtime. These settings include the CL (CAS latency) timing specification which needs to be changed to adapt to a new frequency operation.

Force Auto-Refresh

Bit 20 (=1) forces the auto refresh to be immediately executed (not waiting until the refresh counter has expired). This is useful for test purposes but also to synchronize the refresh time base with a system relevant time base.

Shared Memory Interface (ADSP-21368)

The ADSP-21368 processor supports connections to a common shared external memory of other ADSP-21368 processors. These connections create shared external bus processor systems. This support includes:

- Shared memory space $\overline{MS3-0}$ for AMI and SDRAM
- Distributed, on-chip arbitration for the shared external bus
- Fixed and rotating priority bus arbitration
- Bus time-out logic
- Bus lock
- Booting

Figure 3-12 illustrates a basic shared memory system. In a system with several processors sharing the external bus, any of the processors can become the bus master. The bus master has control of the bus, which consists of the DATA31-0 and ADDR23-0 pins and associated control lines.

 In a shared memory system, programs should not reset the current bus master as this leads to system synchronization problems.

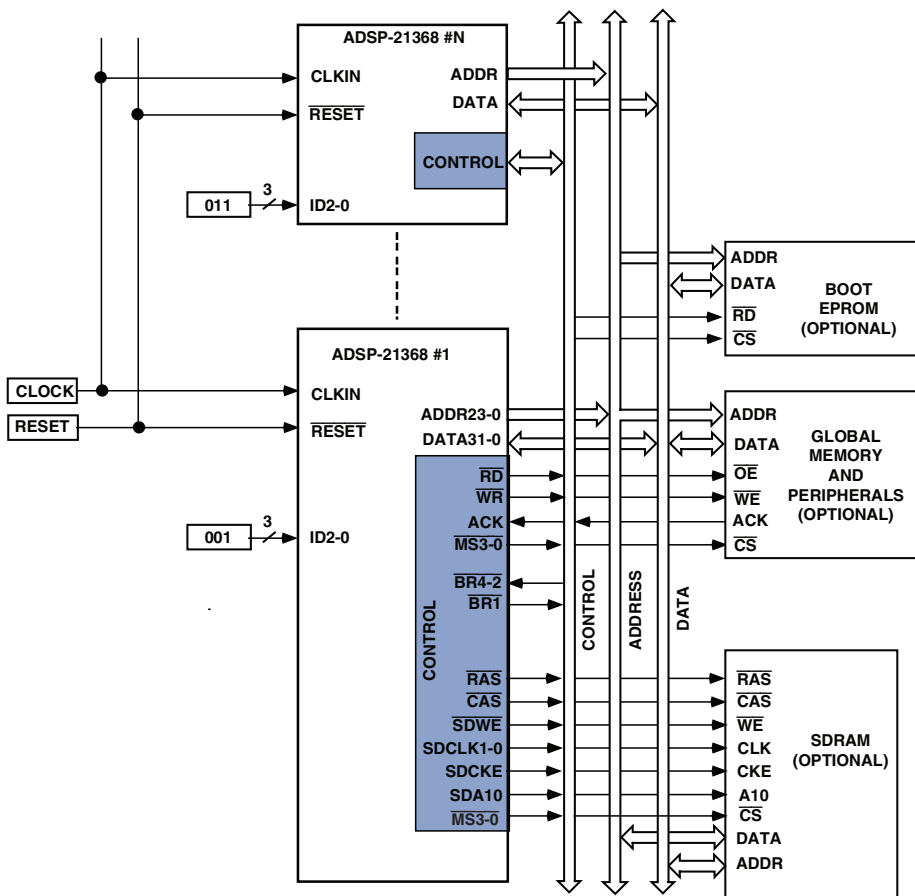

Figure 3-12. ADSP-21368 Shared Memory System

Shared Memory Interface (ADSP-21368)

Pin Descriptions

The pins used by the shared external memory interface are described in *ADSP-21367/ADSP-21368/SHARC/ADSP-21369 Processor Data Sheet*.

Functional Description

Multiple processors can share the external bus with no additional arbitration logic as shown in [Figure 3-12](#). Arbitration logic is included on chip to allow the connection of up to four ADSP-21368 processors.

The processor accomplishes bus arbitration through the $\overline{\text{BR1-4}}$ signals which arbitrate between multiple processors. The priority scheme for bus arbitration is determined by the RPBA pin setting.

The ID2-0 pins provide a unique identity for each processor in a multiprocessing system. The first processor should be assigned $\text{ID} = 001$, the second should be assigned $\text{ID} = 010$, and so on. One of the processors must be assigned $\text{ID} = 001$ in order for the bus synchronization scheme to function properly.

 The processor with $\text{ID} = 001$ holds the external bus control lines stable (pull-up enabled) during reset.

A processor in a shared memory system can determine which processor is the current bus master by reading the CRBM2-0 bits of the SYSTAT register (see *SHARC Processor Programming Reference*). These bits provide the values of the ID2-0 inputs of the current bus master.

Bus Arbitration Protocol

The bus request ($\overline{\text{BR1-4}}$) pins are connected between each processor in a shared memory system, where the number of $\overline{\text{BRx}}$ lines used is equal to the number of processors in the system. Each processor drives the $\overline{\text{BRx}}$ pin that corresponds to its ID2-0 inputs and monitors all others.

 If less than four processors are used in the system, the unused $\overline{\text{BRx}}$ pins should be tied high.

When one of the slave processors needs to perform an access to the shared memory space it needs to become bus master, it automatically initiates the bus arbitration process by asserting its $\overline{\text{BRx}}$ line at the beginning of the cycle. Later in the same cycle, the processor samples the value of the other $\overline{\text{BRx}}$ lines.

The cycle in which mastership of the bus is passed from one processor to another is called a bus transition cycle (BTC). A BTC occurs when the current bus master's $\overline{\text{BRx}}$ pin is deasserted and one or more of the slave's $\overline{\text{BRx}}$ pins is asserted. The bus master can retain bus mastership by keeping its $\overline{\text{BRx}}$ pin asserted.

By observing all of the $\overline{\text{BRx}}$ lines, each processor can detect when a bus transition cycle occurs and which processor has become the new bus master. A bus transition cycle is the only time that bus mastership is transferred.

After conditions determine that a bus transition cycle is going to occur, every processor in the system evaluates the priority of the $\overline{\text{BRx}}$ lines asserted within that cycle. For a description of bus arbitration priority, see [“Rotating Priority Bus Arbitration \(RPBA\)” on page 3-56](#). The processor with the highest priority request becomes the bus master on the following cycle, and all of the processors update their internal records to indicate which processor is the current bus master. [Figure 3-13](#) shows typical timing for bus arbitration.

Shared Memory Interface (ADSP-21368)

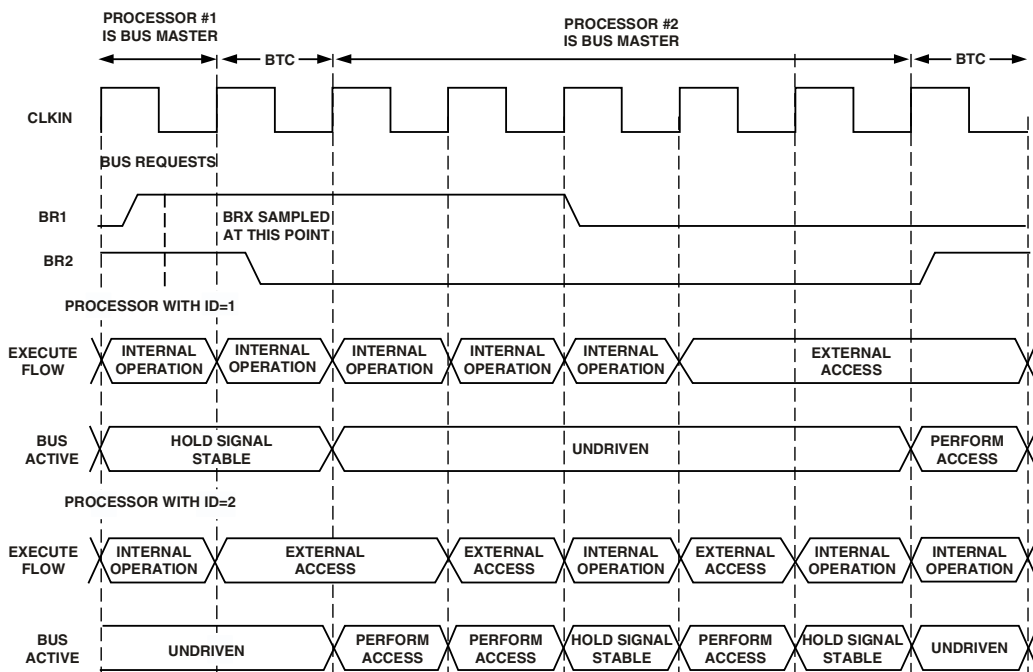

Figure 3-13. Bus Arbitration Timing

The actual transfer of bus mastership is accomplished by the current bus master three-stating the external bus— DATA_{31-0} , ADDR_{23-0} , $\overline{\text{RD}}$, $\overline{\text{WR}}$, and $\overline{\text{MS}}_{3-0}$ (or SDRAM control signals)—at the end of the bus transition cycle and the new bus master driving these signals at the beginning of the next cycle. The bus strobes $\overline{\text{RD}}$, $\overline{\text{WR}}$, and $\overline{\text{MS}}_{3-0}$ (or SDRAM control signals) are driven high (inactive) before three-stating occurs. The ACK signal must be sampled high by the new master before it starts a new bus operation. For more information, see [Figure 3-14](#).

During bus transition cycle delays, execution of external accesses are delayed. When one of the slave processors needs to perform a read or write to the shared memory space, it automatically initiates the bus arbitration process by asserting its $\overline{\text{BR}}_{\text{x}}$ line. This read or write is delayed until the

processor receives bus mastership. If the read or write was generated by the processor's core or the I/O processor, program execution stops on that processor until the instruction is completed.

i The next bus master requester of an ADSP-21368 can't interrupt a current DMA to the shared memory unlike previous SHARCs by using \overline{PA} pins. Instead the new bus master has to wait until the DMA has completed.

The following steps occur as a slave acquires bus mastership and performs an external read or write over the bus as shown in [Figure 3-14](#).

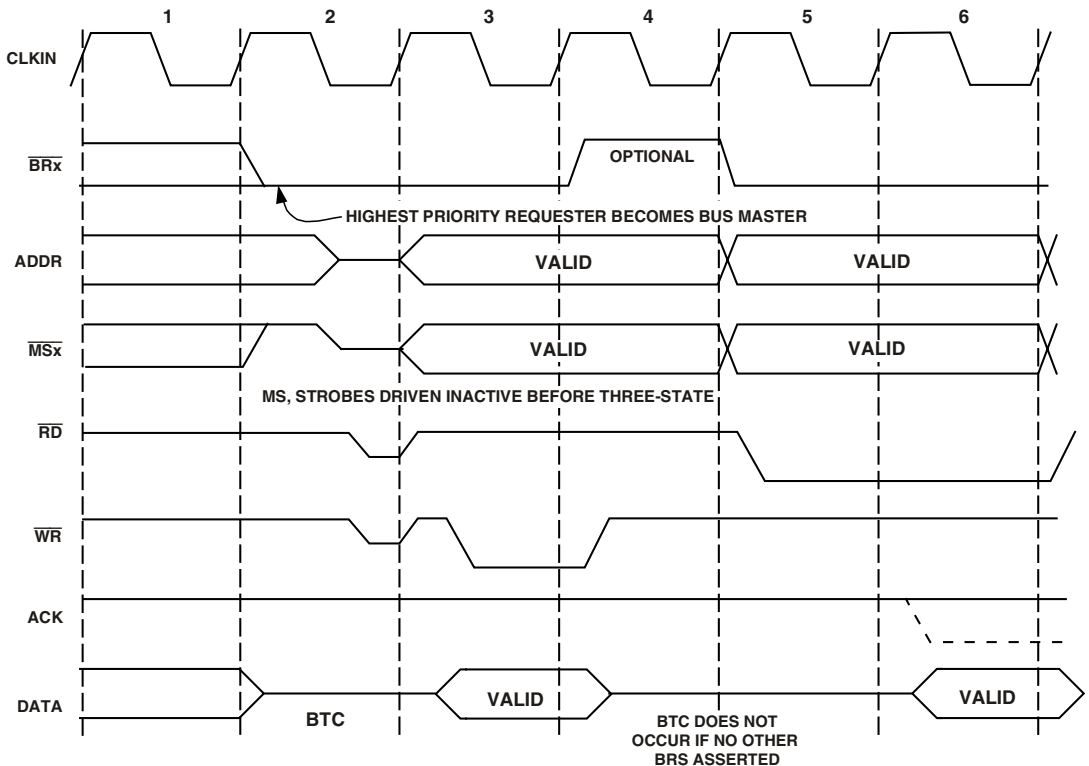



Figure 3-14. Bus Request and Read/Write Timing

Shared Memory Interface (ADSP-21368)

1. The slave determines that it is executing an instruction which requires an off-chip access. It asserts its $\overline{\text{BRX}}$ line at the beginning of the cycle. Extra cycles are generated by the core processor (or I/O processor) until the slave acquires bus mastership.
2. To acquire bus mastership, the slave waits for a bus transition cycle in which the current bus master deasserts its $\overline{\text{BRX}}$ line. If the slave has the highest priority request in the BTC, it becomes the bus master in the next cycle. If not, it continues waiting.
3. At the end of the BTC, the current bus master releases the bus and the new bus master starts driving.

During the CLKIN cycle in which the bus master deasserts its $\overline{\text{BRX}}$ output, it three-states its outputs in case another bus master wins arbitration and enables its drivers in the next CLKIN cycle. If the current bus master retains control of the bus in the next cycle, it enables its bus drivers, even if it has no bus operation to run.

-  The fundamental clock for the bus arbitration is the CLKIN input. Therefore all bus members must share the same CLKIN oscillator. Note the higher CLKIN the higher the bus arbitration speed.

The ADSP-21368 processor with $\text{ID} = 001$ enables internal pull-up devices on key signals, including the address and data buses, strobes, and ACK . These devices provide a weak current source or sink (approximate 20 $\text{k}\Omega$ impedance) to keep these signals from drifting near input receiver thresholds when all drivers are three-stated. Note that single processor systems with $\text{ID} = 000$ also enable these pull-up devices.

When the bus master stops using the bus, its $\overline{\text{BRx}}$ line is deasserted, allowing other processors to arbitrate for mastership if they need it. If no other processors are asserting their $\overline{\text{BRx}}$ line when the master deasserts its $\overline{\text{BRx}}$, the master retains control of the bus and continues to drive the memory control signals until:

1. it needs to use the bus again
2. another processor asserts its $\overline{\text{BRx}}$ line

Bus Synchronization After Reset

When a shared memory system comes out of reset (after $\overline{\text{RESET}}$ is asserted), the bus arbitration logic on each processor must synchronize, ensuring that only one processor drives the external bus. One processor must become the bus master, and all other processors must recognize it before actively arbitrating for the bus. The bus synchronization scheme also lets the system safely bring individual processors into and out of reset.

One of the processors in the system must be assigned $\text{ID} = 001$ in order for the bus synchronization scheme to function properly. This processor also holds the external bus control lines stable during reset.

 Bus arbitration and synchronization are disabled if the processor is in a single processor system ($\text{ID} = 000$).

To synchronize their bus arbitration logic and define the bus master after a system reset, the multiple processors obey the following rules:

- All processors except the one with $\text{ID} = 001$ deassert their $\overline{\text{BRx}}$ line during reset. They keep their $\overline{\text{BRx}}$ deasserted for at least two cycles after reset and until their bus arbitration logic is synchronized.
- After reset, a processor considers itself synchronized when it detects a cycle in which only one $\overline{\text{BRx}}$ line is asserted. The processor identifies the bus master by recognizing which $\overline{\text{BRx}}$ is asserted and updates its internal record to indicate the current master.

Shared Memory Interface (ADSP-21368)

- The processor with $ID = 001$ asserts its \overline{BRX} during reset and for at least two cycles after reset. If no other \overline{BRX} lines are asserted during these cycles, the processor with $ID = 001$ drives the memory control signals to prevent glitches. Although the processor with $ID = 001$ is asserting its \overline{BRX} and driving the memory control signals during these cycles, this processor does not perform reads or writes over the bus.
- While in reset, the processor with $ID = 001$ attempts to gain control of the bus by asserting \overline{BRI} .
- While in reset, the processor with $ID = 001$ drives the \overline{RD} , \overline{WR} , and $\overline{MS3-0}$ signals only if it determines that it has control of the bus. For the processor to decide it has control of the bus: 1) its \overline{BRI} signal must be asserted and 2) in the previous cycle, no other processor's \overline{BRX} signals were asserted.

The processor with $ID = 001$ continues to drive the \overline{RD} , \overline{WR} , and $\overline{MS3-0}$ signals for two cycles after reset, as long as other \overline{BRX} lines are asserted.

If the processor with $ID = 001$ is synchronized by the end of the two cycles following reset, it becomes the bus master. If it is not synchronized at this time, it deasserts its \overline{BRX} and stops driving the memory control signals and does not arbitrate for the bus until it becomes synchronized. When a processor has synchronized itself, it sets the $BSYN$ bit in the $SYSTAT$ register.

Note the $BSYN$ bit ($SYSTAT$ register) will be set after de-assertion of $\overline{RESET-OUT}$ pin for minimum delay of 1 $CLKIN$ cycle or more.

If one processor comes out of reset after the others have synchronized and started program execution, that processor may not be able to synchronize immediately (for example, if it detects more than one \overline{BRX} line asserted). If the non-synchronized processor tries to execute an instruction with an off-chip read or write, it cannot assert its \overline{BRX} line to request the bus and execution is delayed until it can synchronize and correctly arbitrate for the bus.

During reset, the `ACK` line is pulled high internally by the processor bus master with a 20 k Ω equivalent resistor.

Shared AMI Protocol

If the optional `ACK` signal is enabled (`AMICTLx`), it must be sampled high by the new master before it starts a new bus operation.

 The `ACK` pin is optional for AMI usage to insert wait states, it is not required for SDRAM systems.

Shared SDRAM Protocol

In a shared memory environment, the SDRAM is shared among two or more ADSP-21368 processors. SDRAM input signals (including clock) are always driven by the bus master. The current bus master continues to hold the bus for $t_{RASmin} - 1$ cycles before giving up the bus to the new bus master.

The SDRAM clock is three-stated on releasing the bus, and command lines are driven for one extra cycle with a `NOP` instruction. The new bus master also drives a `NOP` on the command lines immediately after acquiring the bus mastership. This prevents latching of invalid commands due to glitches on the clock, (if any) during bus mastership changeover.

The following should be noted when using the SDRAM controller in a shared memory system.

1. Processors do not track SDRAM commands on the bus (unlike previous SHARCs).
2. The master processor issues a refresh command immediately after getting bus-mastership and clearing its refresh counter. This simplifies the design and avoids maintaining the refresh counters in sync on all processors using an overhead of a few clock cycles on each mastership changeover.

Shared Memory Interface (ADSP-21368)

3. For shared SDRAM timing, all processors must have the same $SDCLK$ frequency, and the same core clock ($CCLK$) to SDRAM clock ($SDCLK$) ratio. This implies that all processors must use the same settings in their respective control ($SDCTL$) and refresh rate ($SDRRC$) registers.

Operating Modes

The following sections describe the operating modes that can be used with shared memory.

Rotating Priority Bus Arbitration (RPBA)

To resolve competing bus requests, there are two available priority schemes—fixed and rotating. The $RPBA$ pin selects the scheme. When $RPBA$ is high, rotating priority bus arbitration is selected, and when $RPBA$ is low, fixed priority is selected. The $RPBA$ pin must be set to the same value on each processor in a multiprocessing system.

In the fixed priority scheme, the processor with the lowest ID number among the competing bus requests becomes the bus master. If, for example, the processor with $ID = 010$ and the processor with $ID = 100$ request the bus simultaneously, the processor with $ID=010$ becomes bus master in the following cycle.

 Each processor knows the ID of the other processors requesting the bus, because the ID corresponds to the \overline{BRX} line being used for each processor.

The rotating priority scheme gives roughly equal priority to each processor. When rotating priority is selected, the priority of each processor is reassigned after every transfer of bus mastership. Highest priority is rotated from processor to processor as if they were arranged in a circle—the processor with the next highest ID setting from the current bus master is the one that receives highest priority. [Table 3-11](#) shows an example of how rotating priority changes on a cycle-by-cycle basis.

Table 3-11. Rotating Priority Arbitration Example

Cycle Number	Hardwired Processor IDs and Priority ¹			
	ID1	ID2	ID3	ID4
1 ²	M	1	2- $\overline{\text{BR}}$	3
2	2	3- $\overline{\text{BR}}$	M- $\overline{\text{BR}}$	1
3	2	3- $\overline{\text{BR}}$	M	1
4	3- $\overline{\text{BR}}$	M	1	2- $\overline{\text{BR}}$
5 ³	1- $\overline{\text{BR}}$	2	3	M

- 1 The following symbols appear in these cells: 1-3 = assigned priority, M = bus mastership (in that cycle), $\overline{\text{BR}}$ = requesting bus mastership with $\overline{\text{BRx}}$.
- 2 Initial priority assignments.
- 3 Final priority assignments.

Bus Mastership Time-Out

In either the fixed or rotating priority scheme, systems may need to limit how long a bus master can retain the bus. This is accomplished by forcing the bus master to deassert its $\overline{\text{BRx}}$ line after a specified number of CLKIN cycles and giving the other processors a chance to acquire bus mastership.

To set up a bus master time-out, a program must load the bus time-out maximum (BMAX register, 16-bit) with the maximum number of CLKIN cycles (minus 2) that allows the processor to retain bus mastership. This equation is shown below.

$$\text{BMAX} = (\text{maximum number of bus mastership } \text{CLKIN} \text{ cycles}) - 2$$

The minimum value for BMAX is 2, which lets the processor retain bus mastership for four CLKIN cycles. Setting $\text{BMAX}=1$ is not allowed. To disable the bus master time-out function, set $\text{BMAX}=0$.

Data Transfer

Each time a processor acquires bus mastership, its bus time-out counter (BCNT register, 16-bit) is loaded with the value in BMAX. The BCNT is then decremented in every CLKIN cycle in which the master performs a read or write over the bus and any other (slave) processors are requesting the bus. Any time the bus master deasserts its $\overline{\text{BRX}}$ line, BCNT is reloaded from BMAX.

When BCNT decrements to zero, the bus master first completes its off-chip read/write and then deasserts its own $\overline{\text{BRX}}$ (any new off-chip accesses are delayed), which allows transfer of bus mastership. If the ACK signal is holding off an access when BCNT reaches zero, bus mastership is not relinquished until the access can complete.

If BCNT reaches zero while bus lock is active, the bus master does not deassert its $\overline{\text{BRX}}$ line until bus lock is removed. Bus lock is enabled by the BUSLK bit (bit 29 of SYSCTL register). For more information, see “[Bus Synchronization Notes](#)” on page 3-103.

 Note that the priority abort feature ($\overline{\text{PA}}$ pins) from previous ADSP-2116x processors is not implemented. During any access (core/external port DMA), the new master requesting the bus must wait until the present master releases the bus. The new master can not interrupt current bus master transfers. If the current master doesn't have an external transfer, it releases the bus (even before BCOUNT CLKIN cycles).

Data Transfer

The AMI can access data from both the core and through DMA. The following sections describe these options.

Data Buffers

The asynchronous memory interface has two 1 deep data buffers, one each for the transmit and receive operations. These are described in the sections that follow.

Receive Buffer

Reads from external memory are done through the 1 deep transmit packing buffer (AMIRX). When an external address that is mapped to the AMI in the EPCTL register is accessed, it receives 8-bit data and packs the data based on the packing and control modes in the AMI control register (AMICTLx). Once a full packed word is received, the internal status signal is de-asserted and new reads are allowed.

The AMI provides the interface to the external data pins as well as to the processor core or to the internal DMA controller. When the AMI receives data, it is passed by internal hardware to the DMA controller or to the external port control bus, depending on which entity requested the data.

Transmit Buffer

Writes to external memory are done through the 1 deep transmit packing buffer (AMITX). When an external address that is mapped to the AMI in the EPCTL register is accessed, it receives data from internal memory using the DMA controller or through direct core writes.

Once a full word is transferred out of the AMI, the internal status signal is de-asserted and new writes are allowed. No more external transfers can start while the AMI module is not empty.

Whenever the AMITX buffer is empty, the DMA controller or a direct access from the processor core can write new data into the AMI. If the register is full, further writes from the core (or DMA controller) are stalled.

Data Transfer



For core and DMA access, the received data is also unpacked, depending on the setting of the `PKDIS` bit. The order of unpacking is dependent on the `MSWF` bit in `AMICTLx` registers.

Core Access

For core-driven external port transfers, the instruction needs to read or write from a valid external port address.

External Port Dual Data Fetch

On the ADSP-2137x processors, the dual data fetch instruction (Type 1) allows the processor to access external data from both DAGs. In such an instruction, the accesses are executed sequentially (not simultaneously as in internal memory). For example:

```
r4=r2+r3, r2=dm(i6,m6), r3=pm(i10,m10);
```

The DAG1 access (operand `r2`) is executed first followed by the second DAG2 access (operand `r3`).

Conditional Instructions

On the SHARC processors, almost all instruction types can be conditional. The ADSP-2137x processors allow access to external data based on a conditional instruction. For example:

```
r10=pass r9;  
If EQ r4=r2+r3, r2=dm(i6,m6);
```

The instruction is only executed if the condition is true.

External Instruction Fetch (ADSP-2137x)

The ADSP-2137x SHARC processors support direct fetch of instructions from external memory, using the 16-bit external port (on the ADSP-21375) or the 32-bit external port (as on the ADSP-21371). Fetching is supported from external memory bank 0 space which is selected by $\overline{MS0}$. This external memory can either be SDRAM, or asynchronous memory, such as SRAM or flash.

 While 16-bit to 48-bit packing, and 32-bit to 48-bit packing are supported when the external memory is SDRAM, the external asynchronous memory interface (AMI) also supports 8-bit to 48-bit, 16-bit to 48-bit, and 32-bit to 48-bit instruction packing.

Fetching Instructions From External Memory

The SDRAM controller along with the processor core incorporates appropriate enhancements so that instruction code can be fetched from the SDRAM at the maximum possible throughput. Throughput is limited only by the SDRAM when the code is non sequential.

The address map for code is same as for data. Each address refers to a 32-bit word. Any address produced by the sequencer is checked to determine if it falls in the external memory and if so, the SDRAM controller initiates access to the SDRAM. Because the sequencer address bus is limited to 24 bits, only part of the external memory address area can be used to store code. As explained in the following section, the address generated by the sequencer undergoes translation to produce a physical address, since the SDRAM data bus width is less than 48 bits.

Interrupt Vector Table (IVT)

On ADSP-2137x processors, the interrupt vector table can be located in the internal ROM (0x80000, $IIVT$ bit = 0) or internal RAM (0x90000, $IIVT$ bit = 1) based on the selected boot mode. However for all boot modes except the reserved boot mode, the default $IIVT$ bit setting is 1 (SYSCTL).

Data Transfer

Therefore, if instruction fetch from external memory is desired upon reset, the program needs to set up the appropriate interrupt vector tables in internal memory as part of the boot-up code before beginning to fetch these instructions.

When an unmasked interrupt occurs and is serviced, program execution automatically jumps to the location of the corresponding interrupt vector table in internal memory. Upon returning from the interrupt, the sequencer resumes fetching instructions from external memory because locating the IVT in external memory is not supported.

Instruction Packing

Any address produced by the sequencer which falls in external memory is first translated into the physical address in external memory based on the actual data bus width of external memory as shown in [Table 3-15](#).

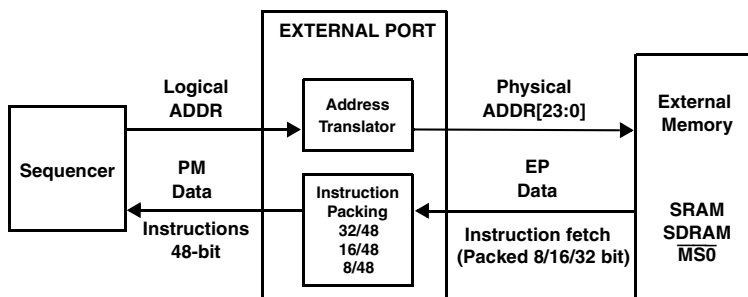



Figure 3-15. Logical Versus Physical Addresses

The controller completes the required number of accesses from consecutive locations for returning a 48-bit word instructions. For a 16-bit SDRAM bus, it performs three accesses. For 32-bit SDRAM, three accesses are performed for two instructions. In this packing mode, all the even addresses in external memory are translated by multiplying the address by a factor of 3/2. For example, if A is an even address falling in external memory region ($A > 0x200000$), the translated address is $((A \gg 1) + A)$. For an odd address, the translated address for the previous

even address is incremented by 1. Note that it is the absolute address rather than the offset from the base of external memory that is translated. Therefore, the beginning of external memory, 0x200000, is translated to 0x300000. Two 32-bit accesses are performed for each even address. For an odd address in the sequence, only one access is necessary. Two accesses are necessary however, if the odd address happens to be first in a sequence.

-  Only bank0 can be populated for external instruction fetch.
-  In contrast to previous SHARC processors (ADSP-2106x and ADSP-2116x) interleaved code packing (32/48 bit) is more efficient fetching 3 words while 2 instructions are packed.

32-Bit Instruction/Data Storage and Packing

In SDRAM, there are additional 2 bits of address generation available IA27–26 to the SDRAM controller. Therefore, the external addressable range is larger than with asynchronous memory and the entire allowable internal address range of 24 bits can be accessed in external memory.

Table 3-13 shows the format of stored instructions in external 32-bit wide memory. The sequencer automatically places the normal word address corresponding to the starting address of the first instruction to be fetched from external memory on the appropriate address bus, fetches two 32-bit words and packs them to form the 48-bit instruction to be executed. The address is automatically incremented, and program execution continues with placing the next address on the external address bus, and so on.

Table 3-12. Logical Versus Physical Address Mapping, 32-Bit AMI/SDRAM

Logical Address, Program Sequencer	Physical Address, External Bus	Data	
0x200000	0x300000	Instr0[31:0]	
	0x300001	Instr1[15:0]	Instr0[47:32]

Data Transfer

Table 3-12. Logical Versus Physical Address Mapping, 32-Bit AMI/SDRAM (Cont'd)

Logical Address, Program Sequencer	Physical Address, External Bus	Data	
0x200001	0x300001	Instr1[47:16]	
	0x300002	Instr2[31:0]	
0x200002	0x300002	Instr3[15:0]	Instr2[47:32]
	0x300003	Instr3[47:16]	
...	...		
0xAAAAA9	0xFFFFFE	InstrN[31:0]	
	0xFFFFFE	0000	InstrN[47:32]
...	...		
0xFFFFF	0xFFFFFD	InstrP[31:0]	
	0xFFFFFE	0000	InstrP[47:32]

In [Table 3-12](#), the logical to physical translation is a multiplication by a factor of 3/2 and $N = 0x8AAAA9$. Therefore, the 32-bit wide AMI supports 8.6 million instructions.

In [Table 3-12](#), $P = 0xE00000$. Therefore, the total number of external memory instructions for a 32-bit wide SDRAM memory is 14.6 million.

16-Bit Instruction/Data Storage and Packing

In [Table 3-13](#) the logical to physical translation is a multiplication by a factor of 3 and $N = 0x355554$. Therefore, the 16-bit wide memory supports 3.3 million instructions.

In [Table 3-13](#) $P = 0xE00000$. Therefore, the total number of external memory instructions for a 16-bit wide SDRAM memory is 14 million.

Table 3-13. Logical Versus Physical Address Mapping, 16-Bit AMI/SDRAM

Logical Address, Program Sequencer	Physical Address, External Bus	Data
0x200000	0x600000	Instr0[15:0]
	0x600001	Instr0[31:16]
	0x600002	Instr0[47:32]
0x200001	0x600003	Instr1[15:0]
	0x600004	Instr1[31:16]
	0x600005	Instr1[47:32]
0x200002	0x600006	Instr2[15:0]
	0x600007	Instr2[31:16]
	0x600008	Instr2[47:32]
...	...	
0x555554	0xFFFFFD	InstrN[15:0]
	0xFFFFFE	InstrN[31:16]
	0xFFFFF	InstrN[47:32]
0xFFFFF	0xFFFFFD	InstrN[15:0]
	0xFFFFFE	InstrN[31:16]
	0xFFFFF	InstrN[47:32]

8-Bit Instruction Storage and Packing

The 8:48-bit instruction packing is supported by the AMI only.

In [Table 3-14](#), the logical to physical translation is a multiplication by a factor of 6 and $N = 0xAAAA9$. Therefore, the 8-bit wide AMI supports 0.7 million instructions.

Data Transfer

Table 3-14. Logical Versus Physical Address Mapping, 8-Bit AMI

Logical Address, Program Sequencer	Physical Address, External Bus	Data7–0
0x200000	0x800000	Instr0[7:0]
	0x800001	Instr0[15:8]
	0x800002	Instr0[23:16]
	0x800003	Instr0[31:24]
	0x800004	Instr0[39:32]
	0x800005	Instr0[47:40]
0x200001	0x800006	Instr0[7:0]
	0x800007	Instr0[15:8]
	0x800008	Instr0[23:16]
	0x800009	Instr0[31:24]
	0x80000A	Instr0[39:32]
	0x80000B	Instr0[47:40]
...	...	
0x2AAAA9	0x2FFFFFFA	Instr0[7:0]
	0x2FFFFFFB	Instr0[15:8]
	0x2FFFFFFC	Instr0[23:16]
	0x2FFFFFFD	Instr0[31:24]
	0x2FFFFFFE	Instr0[39:32]
	0x2FFFFFFF	Instr0[47:40]

Mixing Instructions and Data in External Bank 0

It is possible to store both 48-bit instructions as well as 32-bit data in external memory bank 0. However, care must be taken while specifying the proper starting addresses if 48-bit instructions are stored or interleaved with 32-bit data in the same memory bank.

In 32-bit wide external SDRAM memory, two instructions are packed into three 32-bit memory locations, while 32-bit data occupies one memory location. For example, if 2k instructions are placed in 32-bit wide external memory starting at the bank 0 normal-word base address 0x0030 0000 (corresponding to instruction address 0x0020 0000) and ending at address 0x0030 0BFF (corresponding to instruction address 0x0020 07FF), then data buffers can be placed starting at an address that is offset by 3k 32-bit words (for example, starting at 0x0030 0C00).

Instruction Cache

To circumvent the relative difference in clock domains between the core and external memory interface (1:2 in the best case) and enable faster execution throughput, the functionality of the traditional “conflict” cache on the SHARC has been enhanced to serve as an instruction cache in external execution mode.

In previous generations of SHARC processors, the function of the conflict cache had been to cache only those instructions whose fetching conflicted with access of a data operand from memory over the PM bus. The enhancements to the cache architecture mean that the functionality of the cache remains intact for execution from internal memory whereas it behaves as instruction cache for external memory execution.



Every instruction that is fetched from external memory into the program sequencer is also simultaneously loaded into the cache.

Data Transfer

The next time that this instruction needs to be fetched from external memory, it is first searched for in the cache. The instruction is stored using the entire 24-bit address. Figure 3-16 shows the format for storing an instruction.

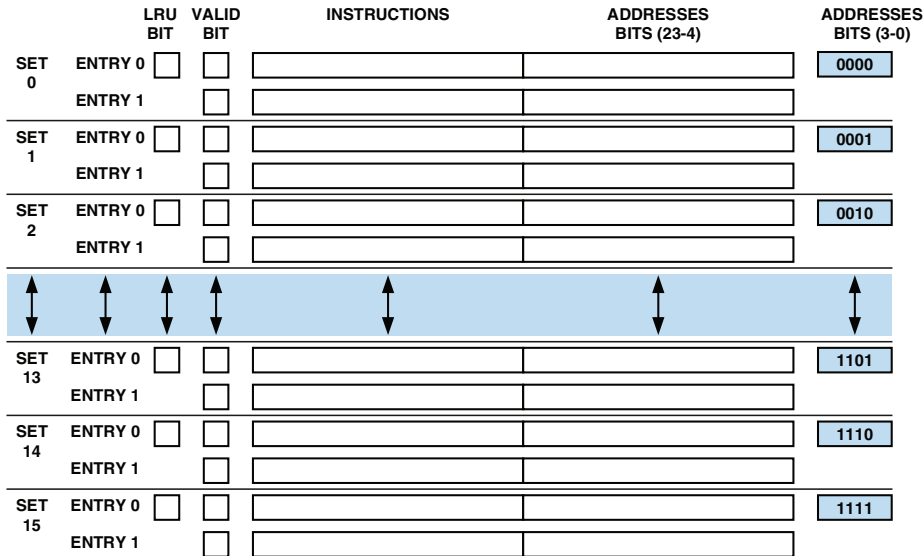

Figure 3-16. Instruction Cache Architecture

In other words, the 32-entry 2-way set-associative cache in the SHARC has been modified to act as an instruction cache when the program sequencer executes instructions from external memory, while continuing to work as the traditional conflict cache when the sequencer executes instructions located in internal memory. This context switching from conflict cache to instruction cache and vice-versa happens automatically without the need for any user intervention.

The first time that an instruction from a particular address is fetched from external memory, there is a cache miss when the sequencer looks for this instruction within the cache. Consequently, the instruction has to be fetched from external memory and a copy of instruction is stored in cache.

Upon subsequent executions of this instruction, the sequencer search results in a cache hit, resulting in the instruction being fetched from cache instead of external memory. This allows for an instruction throughput that is equivalent to internal memory execution.

This context-dependent caching preserves the cache performance of the traditional SHARC conflict cache as well as significantly improving program instruction throughput for repetitive instructions such as those inside loops when executing from external memory. Analyses of typical application code examples have shown that this 32-entry instruction cache improves execution throughput by 50-80% over not having this cache.

In general, cache hits occur for all instructions which are fetched and executed multiple times (for example loops, subroutine calls, negative branches, and so on). Typical applications, such as signal processing algorithms, are ideal candidates for significant performance improvements as a result of the cache.

An important and significant result of the instruction being fetched from the cache is that it frees up the external port as well as the internal PM and DM buses for other operations such as data transfers, operand fetches, or DMA transfers.

The following example shows the innermost loop of a FIR filter.

```
lcntr=FILTER_TAPS-1, do macloop until lce;
    macloop: f12=f0*f4, f8=f8+f12, f0=dm(i0,m1), f4=pm(i9,m9);
```

In this example, if the code is stored and executed from external memory, the first time through this loop the program sequencer places the appropriate 24-bit address on the external address bus, and fetches the instruction in line 2 from external memory. While this instruction is being fetched and processed by the sequencer, it is also simultaneously stored in the internal instruction cache.

Data Transfer

For every subsequent iteration of this loop, the instruction is fetched from the internal cache, thereby occurring in a single cycle, while freeing up the internal memory buses to fetch the data operands required for the instruction.

Previously, in the absence of the internal instruction cache, the number of cycles taken by the loop for a case of `FILTER_TAPS = 16` would have been a minimum of 48 cycles over a 16-bit wide external bus, and 24 cycles over a 32-bit wide external bus (excluding any conflicts for data operand fetches). However, with the presence of the instruction cache, and assuming that the execution is from external SDRAM, and that the instructions are on the same SDRAM page, the number of cycles is reduced to 17 over a 16-bit wide external bus, and either 15 cycles or 16 cycles over a 32-bit wide bus (depending on whether instruction 1 begins on an even 32-bit address, or odd 32-bit address).

Thus, the internal cache improves the efficiency of execution from 16-bit wide external memory by approximately 64.5% for this example.



As might be expected, it is important to remember that the instruction cache does not play a significant role in improving the efficiency of strictly linearly executed code from external memory.

External Port DMA Transfers

The external port has two DMA channels that can use either the SDRAM controller or the asynchronous memory interface (AMI). The features are described in [Table 3-15](#).

Table 3-15. External Port DMA Feature Summary

Feature	ADSP-2136x	ADSP-2137x
DMA Channels	2	
External to Internal DMA	Yes	
Internal to Internal DMA	No	Yes

Table 3-15. External Port DMA Feature Summary (Cont'd)

Feature	ADSP-2136x	ADSP-2137x
External to External DMA	No	
Master Capable	Yes	
Slave Capable	No	
DMA Types		
Standard	Yes	
Chained	Yes	
Circular Buffer	Yes	
Circular Buffer Chained	Yes	
Delay Line	Yes	
Scatter/Gather	No	Yes
Circular buffer Scatter/Gather	No	Yes

The AMI controller supports DMA with an external data width of 8 bits. The SDRAM controller support DMA with an external data width of 16-bits.

External Port DMA Parameter Registers

These registers are used to set up and control DMA through the processor's external port. For information on these registers and on how to set up DMA transfers, see [“General Procedure for Configuring DMA” on page 2-44](#).

Data Transfer

The registers that control external port DMA are described [Table 3-16](#).

Table 3-16. DMA Parameter Registers

Register	Description	Comment
IIEP _x	Internal Index	Internal Start Address. For delay line DMA, it serves as the delay line write index; for example, the start address of the internal memory buffer for the external write data.
IMEP _x	Internal Modifier	Internal address modifier.
ICEP _x	Internal Count	For delay line DMA, it serves as count for delay line writes, write block size.
EIEP _x	External Index	External start address.
EMEP _x	External Modifier	External address modifier.
ECEP _x	External Count	External memory count, read only (alias of ICEP _x)
CPEP _x	Chain Pointer	Contains address of the next descriptor in internal memory.

Table 3-17. Enhanced DMA Parameter Registers

Register	Description	Comment
ELEP _x	Circular Buffer Length	Hold circular buffer length for circular, delay line DMA, scatter/gather DMA.
EBEP _x	External Base	Hold circular start address for circular, delay line DMA, scatter/gather DMA.
RIEP _x	Read Internal Index	Contains start address of internal memory buffer to which the data read from external memory during delay line DMA reads are to be written into (alias of IIEP _x during delay line DMA).
RCEP _x	Read Count	Contains number of reads from each taplist, read block size (alias of ICEP _x during delay line DMA).
RMEP _x	Read External Modifier	Contains external modifier to be used for delay line reads (alias of EMEP _x during delay line DMA).

Table 3-17. Enhanced DMA Parameter Registers (Cont'd)

Register	Description	Comment
TCEPx	Tap Count	Holds the length of the tap list (the number of taps for delay line DMA, scatter/gather DMA).
TPEPx	Tap List Pointer	Holds address of an array in internal memory which holds offsets to be used when accessing delay line DMA in external memory. The offset represents the first address of each read block. Applies to delay line DMA, scatter/gather DMA

Operating Modes

This section highlights the different DMA modes which can be used with the external port.

Internal DMA Addressing

Besides the traditional internal to external addressing type, the DMA module also supports internal to internal transfers. This is accomplished by indexing all external parameter registers with internal addresses. The DMA controller recognizes the transfer by addresses and not by an additional control bit setting.

 Note that the DMA channel priority changes if using internal vs. external index addresses (ADSP-2137x only).

The SHARC supports another internal to internal DMA module (MTM) which has higher priority by default but does only support standard DMA mode. For more information, see [Chapter 4, “Memory-to-Memory Port DMA”](#).

Standard DMA

This DMA type resembles the traditional DMA type to initialize the different internal and external parameters (index, modify and count) registers and configuration of the DMA control registers.

Data Transfer

Note that the `ECEP` parameter register (read only) is a copy of the `ICEP` register. If `ICEP` is written, the `ECEP` register is updated automatically (Figure 3-17).

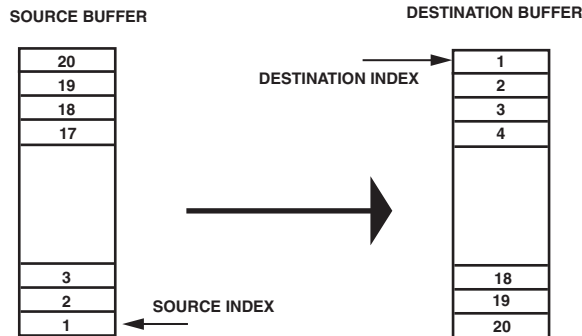

Figure 3-17. Standard Write

Circular Buffered DMA

Circular buffered DMA (Figure 3-18, Figure 3-19) resembles the traditional core DAG circular buffered mode by using registers for circular buffering. In this mode the DMA needs two additional registers (base and length) to support reads and writes to a circular buffer.

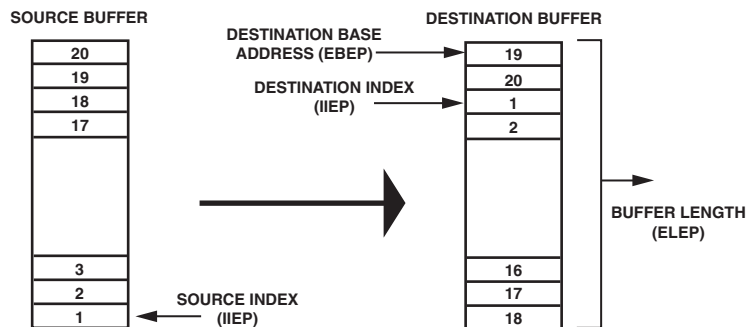

Figure 3-18. Circular Buffering Write DMA

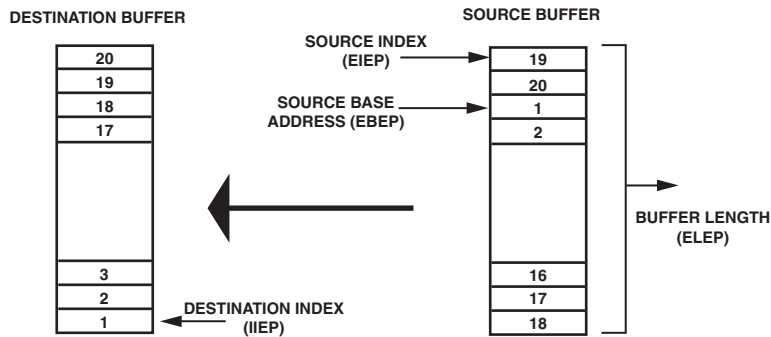

Figure 3-19. Circular Buffering Read DMA

Chained DMA Mode

Chained DMA is used to support repetitive reads and writes to a specific area which is defined by the individual TCBs.

i On ADSP-21367/8/9 processors, the DMA controller uses the same TCB for standard DMA and circular buffer DMA. The $ELEP_x$ and $EBEP_x$ registers need to be programmed explicitly and are therefore valid for all TCB blocks.

Changing DMA Direction on the Fly (ADSP-2137x)

The SHARC processors allow a change of external port data direction for each individual TCB in a chain sequence.

Bit 20 ($CPDR$) bit of the external port chain pointer register ($CPEP_x$) changes the data flow direction. If $CPDR$ is cleared ($=0$) writes to internal memory are performed, if $CPDR$ is set ($=1$), internal memory reads are performed. This works similar to the PCI bit (bit 19). Bit 8 ($OFCEN$) and bit 2 ($CHEN$) in the $DMAC_x$ register must be set ($=1$) to enable this functionality.

Listing 3-4. Changing DMA Direction

```
.section/pm seg_dmda;
/* EP TCB storage order CP-EM-EI-C-IM-II */
.var TCB1[6] = 0 , M , extbuffer , N , M , buffer;
.var TCB2[6] = 0 , M , extbuffer , N , M , buffer;

.section/pm seg_pmco;
R0=0;
dm(CPEP0)=R0;          /* clear CPx register */

r0 = DEN|CHEN|OFCEN;   /* enable DMA channel */
dm(DMAC0)=r0;

R2=(TCB1+5) & 0x7FFFF; /* load IIX address of next TCB and
                        mask address */
R2=bset R2 by 19;      /* set PCI bit */
dm(TCB2)=R2;          /* write address to CPx location of
                        current TCB */
R2=(TCB2+5) & 0x7FFFF; /* load IIX address of next TCB and
                        mask address*/
R2=bset R2 by 19;      /* clear PCI bit */
R2=bset R2 by 20;      /* set CPDR bit */
dm(TCB1)=R2;          /* write address to CPx location of
                        current TCB */
dm(CPEP0)=R2;         /* write IIX address of TCB1 to CPx
                        register to start chaining*/
```



If chaining is enabled with the OFCEN bit set then the TRAN bit has no effect, and direction is determined by the CPDR bit in the CPEP register.

Scatter/Gather DMA (ADSP-2137x)

The purpose of scatter/gather DMA ([Table 3-18](#), [Figure 3-20](#) through [Figure 3-23](#)) is the transfer of data from/to non contiguous memory blocks.

The scatter/gather DMA type is a fixed block size scatter/gather DMA that relies on tap list entries in internal memory to calculate the external address to scatter/gather the DMA. If the DMA direction is external write ($TRAN = 1$) then it is a scatter DMA. If $TRAN = 0$ then it is a gather DMA. This mode also supports chained and circular buffer chained DMAs.

External Address Calculation

For scatter/gather DMA, the tap list modifiers are employed and the number of taps is determined by the tap list count register ($TCEP_x$). The number of sequential reads (block size) from every tap is determined by the internal count register ($ICEP_x$), and is the same for every tap. The read/write pointer in external index register ($EIEP_x$) serves as the index address for these read/writes.

Table 3-18. External Read/Write Index Calculation
Scatter/Gather DMA

Equation	Result
$EIEP + TL[N]$	First address for tap N
$EIEP + TL[N] + 1 \times EMEP$	Second address for tap N
$EIEP + TL[N] + 2 \times EMEP$	Third address for tap N
...	
$EIEP + TL[N] + ICEP \times EMEP$	Final address for tap N
$EIEP + TL[N + 1]$	First address for tap N + 1
$EIEP + TL[N + 1] + 1 \times EMEP$	Second address for tap N + 1

$TL[N]$ is the first tap list entry in the internal memory as pointed by the $TPEP$, the tap list pointer. The tap list entries are 27-bit signed integers. Therefore, for each read/write block, the DMA state machine fetches the offset from the tap list. The offset is added to the $EIEP$ value to get the start address of the next block. The external addresses are circular buffered if circular buffering is enabled (Figure 3-22, Figure 3-23).

Data Transfer

Once the ICEP register for the final tap decrements to zero (both TCEP and ICEP are zero), then the tap list DMA access is complete and the DMA completion interrupt is generated (if chaining is enabled the interrupt depends on the PCI bit setting).

The write back mode (WRBEN bit) is not applicable for tap list based DMA (as the addressing is pre-modify, and therefore the EIEP value coincides with the TCB value even at the end of DMA). So even if the WRBEN bit is set in tap list DMA mode, the write backs do not occur.

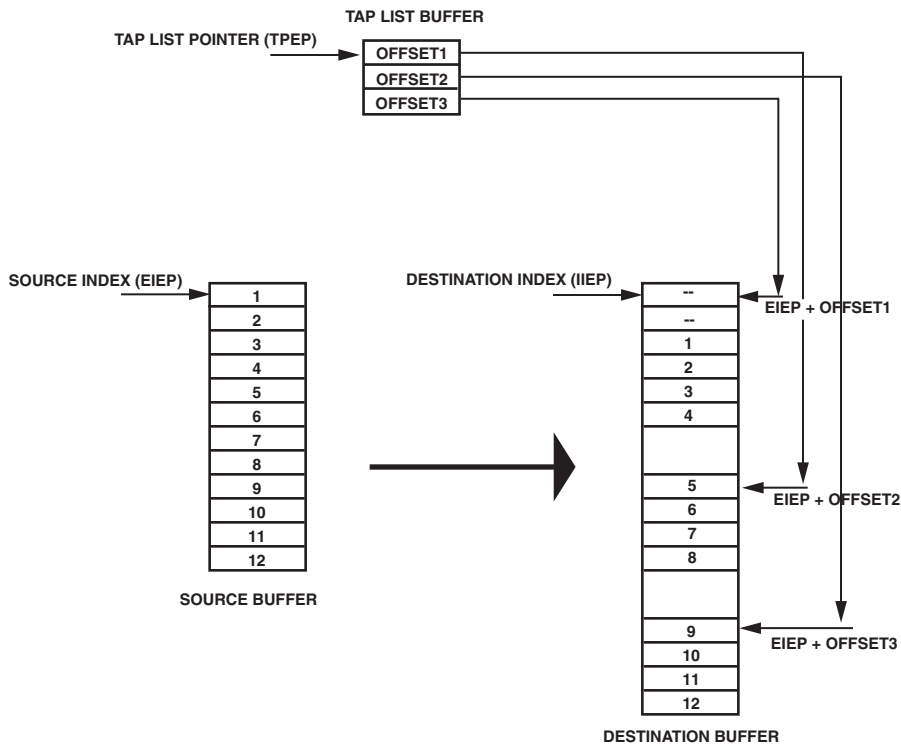

Figure 3-20. Scatter DMA (Writes)

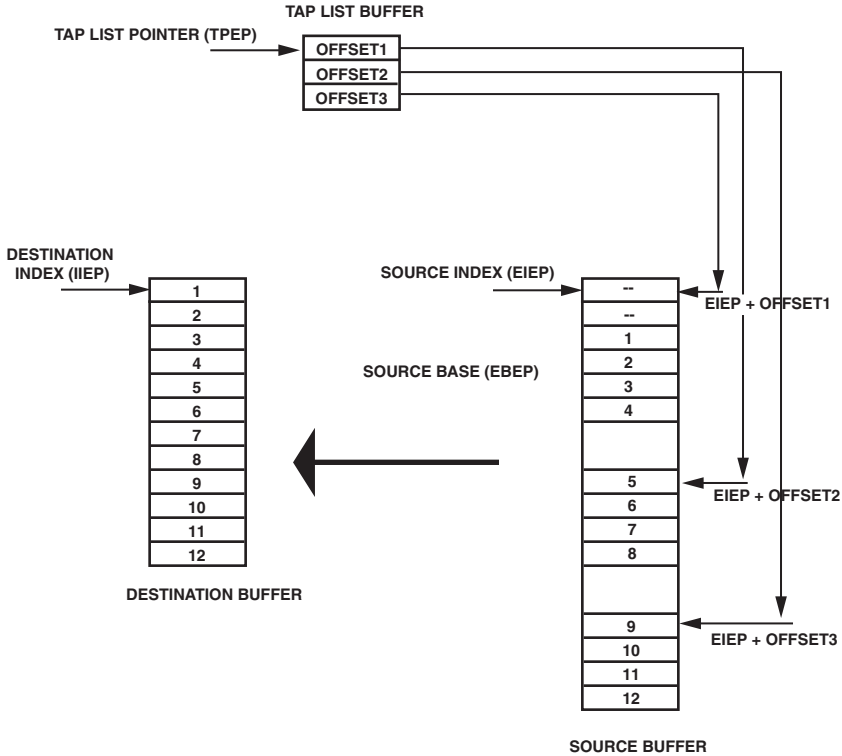

Figure 3-21. Gather DMA (Reads)

Data Transfer

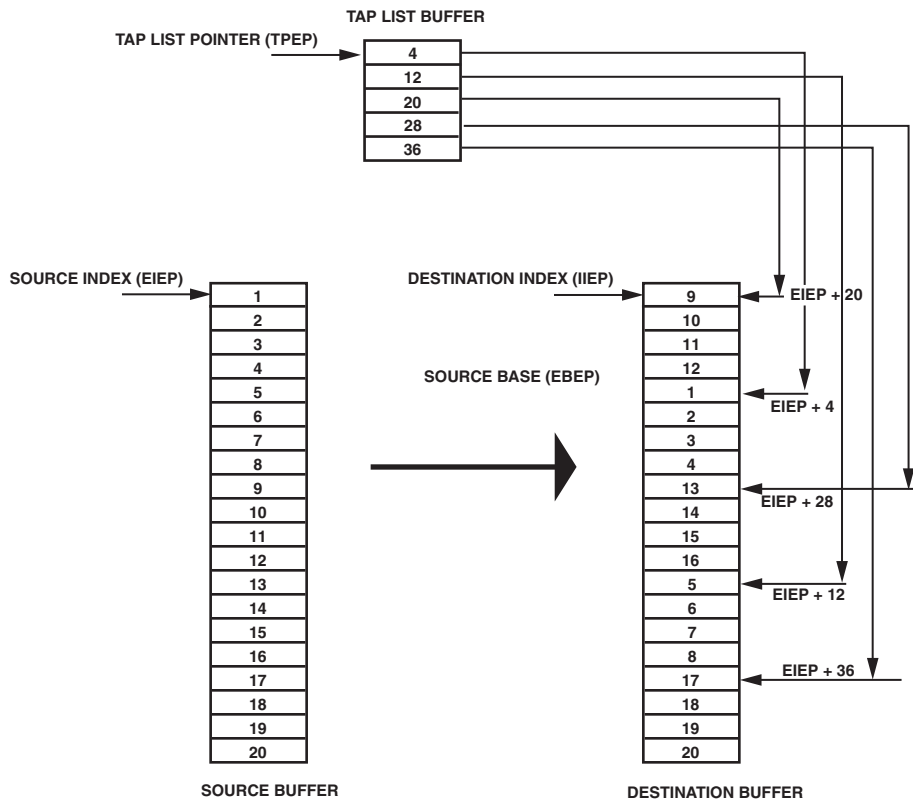

Figure 3-22. Circular Buffering Scatter DMA (Writes)

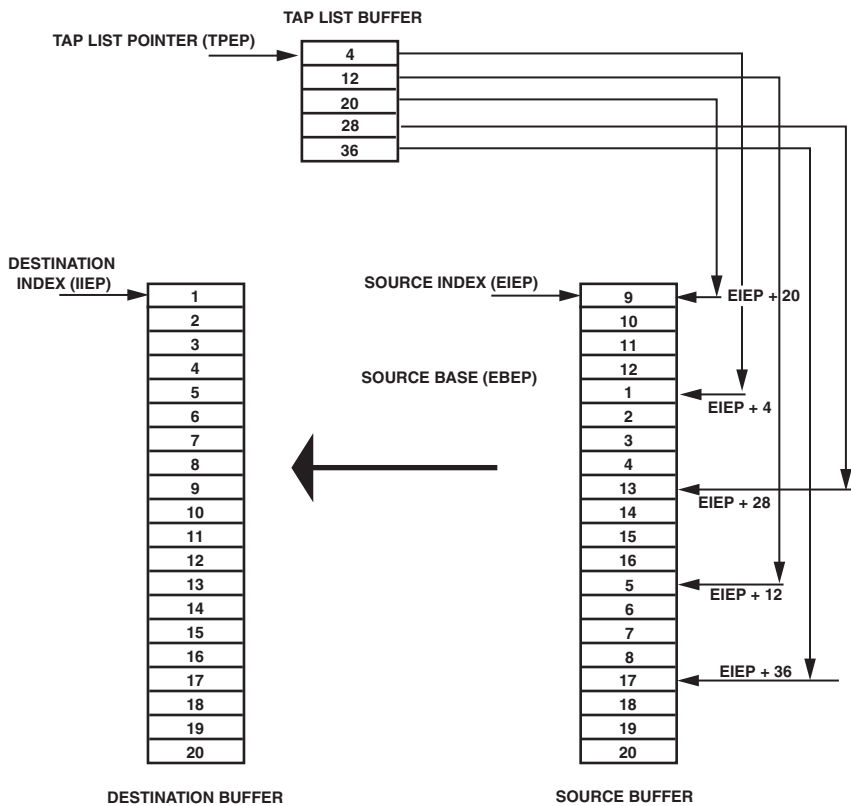

Figure 3-23. Circular Gather DMA (Reads)

Delay Line DMA

Delay line DMA is used to support reads and writes to external delay line buffers with limited core interaction. In this sense, delay line DMA is basically a quantity of integrated writes followed by reads from external memory—called a *delay line DMA access*. Delay line DMA is described in the following sections.

Data Transfer

The delay line DMA access consists of the following accesses in the order listed and is shown in [Figure 3-24](#). Note that in the figure single reads from each TAP are shown for simplicity and block reads are default, depending on the count specified in the `RCEP` register.

1. Writes to external memory. The number of writes is determined by the `ICEP` register. The data is fetched from the `IIEP` register and the `IMEP` register is used as the internal modifier. The `EIEP` register serves as the external index and is incremented by the `EMEP` register after each write. These writes are circular buffered if circular buffering is enabled.
2. In chained DMA, when the writes are complete, (`ICEP = zero`) the `EIEP` register, which serves as the write pointer of the delay line, is written back to the internal memory location from where it was fetched.
3. Reads from external memories. For reads, the tap list (TL) modifiers are used and the number of reads is determined by the `RCEP` register. The write pointer in the `EIEP` register serves as the index address for these reads (reads start from where writes end). The `EIEP` register, along with tap list modifiers, are used in a pre-modify addressing mode to create the external address for the writes. Therefore, for each read, the DMA controller fetches the external modifier from the tap list and the reads are circular buffered (if enabled).

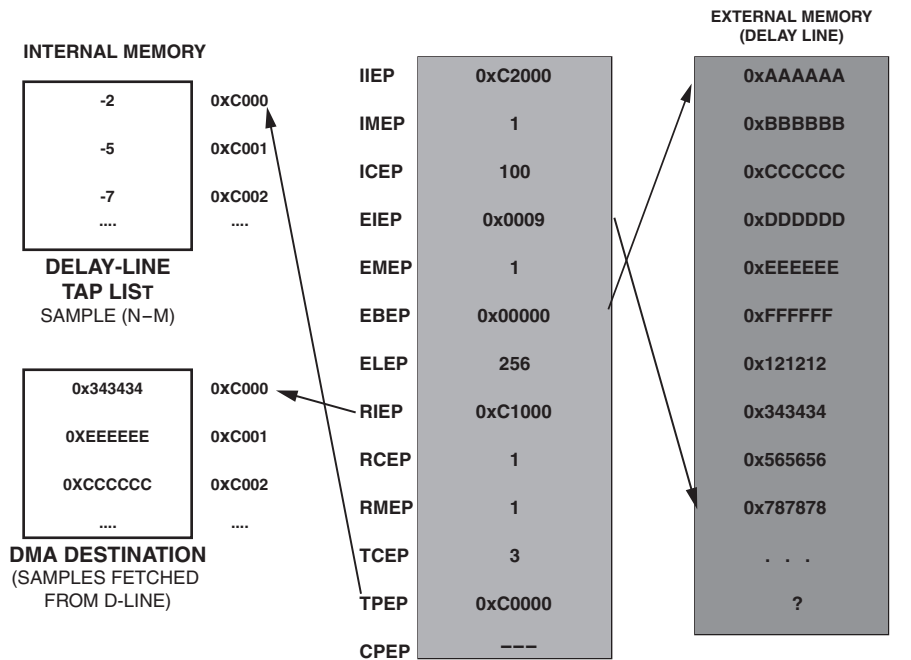

Figure 3-24. Delay Line DMA Reads

External Address Calculation for Reads

Note that TL[N] is the first tap list entry in internal memory pointed to by the tap list pointer register (TPEP). Tap list entries are 27-bit signed integers. Therefore, for each read-block, the DMA state machine fetches the offset external modifier from the tap list. The reads are circular buffered if circular buffering is enabled.

i The external address generation follows pre-modify addressing for reads in delay line DMA and therefore the EIEP register values are not modified. Also the EMEP register does not have any effect during these delay line reads. Once the read count completes, the ICEP register decrements to zero (both ICEP and TCEP are zero) for the final tap. Finally, the delay line DMA access completes and the

Data Transfer

DMA completion interrupt is generated. If chaining is enabled, the interrupt is dependent on the `PCI` bit setting. The delay line DMA can only be initialized using the TCB. In order to use the delay line DMA for a single DMA sequence, initialize the `CPEP` register to zero in the TCB.

 Only the ADSP-21367/8/9 processors do have a 4 deep tap list FIFO which is used to store external memory address after the address pre-modification (base address + Tap list entry).

For each 32-bit tap read, the external read index is shown in [Table 3-19](#).

Table 3-19. External Read Index Calculation Delay Line DMA (ADSP-21367/8/9)

Equation	Result
$EIEP + TL[0]$	First read address for tap 0
$EIEP + TL[1]$	Second read address for tap 1
$EIEP + TL[N]$	Last read address for tap N

Table 3-20. External Read Index Calculation Delay Line DMA (ADSP-2137x)

Equation	Result
$EIEP + TL[N]$	First read address for tap N
$EIEP + TL[N] + 1 \times RMEP$	Second read address for tap N
$EIEP + TL[N] + 2 \times RMEP$	Third read address for tap N
...	
$EIEP + TL[N] + RCEP \times RMEP$	Last read address for tap N
$EIEP + TL[N + 1]$	First read address for tap N + 1
$EIEP + TL[N + 1] + 1 \times RMEP$	Second read address for tap N + 1

Note that on ADSP-21367/8/9 processors each read access from delay line requires a tap list entry. On ADSP-2137x processors, one tap list entry starts multiple reads.

Interrupts

There are two external port DMA channels. The following sections describe the two ways of triggering interrupts. Note that when the core accesses the data buffer, an interrupt is not generated.

Access Completion (ADSP-2137x)

This is the default mode of interrupt generation where the DMA complete interrupt is generated when accesses are completed.

- For external write DMA, the DMA complete interrupt is generated only after external writes on the DMA external interface are done.
- For external read DMA, the DMA complete interrupt is generated when the internal DMA writes complete.

In this mode, the DMA interface can be disabled as soon as the interrupt is received, (there is no need to check `EXTS` before disabling the DMA interface).

 The DMA interface can be disabled based on a DMA complete interrupt. However, the external device interfaces—AMI/SDRAM may still be performing writes of the DMA data. Prior to disabling any of these devices, programs should check their respective status bits.

Internal Transfer Completion

This mode of interrupt generation is enabled when `INTIRT` bit is set in the DMA control register. This mode of interrupt generation resembles traditional SHARC DMA interrupt generation and is provided for backward compatibility. This interrupt is generated once the DMA internal transfers (transmit or receive) are completed. For external transmit DMA, there may be still external access pending at the external DMA interface when the completion interrupt is generated. Therefore, the DMA may be disabled on the DMA complete interrupt only if the external interface is idle (for example, `EXTS = 0`).

Interrupt Dependency on DMA Mode

Interrupt generation varies, depending on the DMA mode used. The `INTIRT` bit determines whether the interrupt is generated on internal completion or access completion. The following also effect interrupt generation.

- For standard chained DMA, if the `PCI` bit is cleared (= 0), the DMA complete interrupt is generated only after the entire chained DMA access is complete. If the `PCI` bit is set (= 1), then a DMA interrupt is generated for each TCB.
- For the delay line DMA, the DMA complete interrupt is generated when both the write access and the delay line reads are completed. In a chained delay line DMA, the `PCI` bit determines if each delay line TCB generates an interrupt or not.
- With scatter/gather DMA, the DMA complete interrupt is generated only after all tap list reads/writes are complete. As in the delay line DMA, the `PCI` bit setting determines if each tap list TCB generates an interrupt in a chained access.



If DMA is disabled in the middle of data transfers, the DMA interrupts should not be used.

External Port Throughput

The following sections provide information on the expected throughput for SDRAM devices under various conditions.

AMI Data Throughput

The AMI data throughput is shown in [Table 3-21](#).

Table 3-21. Read/Write Throughput

Access ¹	8-Bit I/O	16-Bit I/O	32-Bit I/O
Write	32-bit word per 12 cycles	32-bit word per 6 cycles	32-bit word per 3 cycles
Read	32-bit word per 12 cycles	32-bit word per 6 cycles	32-bit word per 3 cycles

¹ Throughput for minimum wait states of 2 with no idle and hold cycles.

SDRAM Throughput

[Table 3-22](#) provides information needed to configure the SDRAM interface for the desired throughput.

Table 3-22. SDRAM Data Throughput

Access	Page	Throughput per SDCLK (32-Bit Data)	Throughput per SDCLK (32-Bit Data)
Sequential uninterrupted reads	Same	32 words per 69 cycles ¹	32 words per 37 cycles ²

External Port Throughput

Table 3-22. SDRAM Data Throughput

Access	Page	Throughput per SDCLK (32-Bit Data)	Throughput per SDCLK (32-Bit Data)
Any writes	Same	2 cycles	Core = 1 word per cycle DMA = 1 word per 2 cycles (ADSP-21367/8/9) DMA = 1 word per cycle (ADSP-2137x)
Non sequential uninterrupted reads	Same	7 cycles	6 cycles

- 1 Optimization enabled, first data of a sequential read takes 7 cycles for CL = 2 and 8 cycles for CL = 3, thereafter it is one word per two cycles.
- 2 Optimization enabled, first data of a sequential read takes 6 cycles for CL = 2 and 7 cycles for CL = 3, thereafter it is one word per cycle.

Throughput Conditional Instructions

ADSP-2136x – A conditional write may take 1 or 1.5 PCLK cycles (access made and access aborted, respectively). A conditional read may occur even if it is aborted. [For more information, see “External Memory Access Restrictions” on page 3-105.](#)

ADSP-2137x – A conditional read/write may take 1 PCLK cycle (access made and access aborted, respectively).

External Instruction Fetch Throughput (ADSP-2137x)

The actual throughput execution from external SDRAM is dependent on the configuration of the SDRAM. The SDRAM can be programmed to run at a number of different frequency ratios with respect to the core clock, the fastest being half of the core clock (or the same as the peripheral

clock). The core and SDRAM controller have been enhanced so that throughput is maximized when SDRAM is programmed to run at half the core clock frequency and the instructions being fetched are sequential.

 Read optimization logic does not apply to external code execution.

Table 3-23 illustrates the performance of code execution depending on different access types.

Table 3-23. Core Throughput

Access	Data Width	Page	Throughput per SDCLK (CL = 2)	Throughput per SDCLK (CL = 3)
Sequential and uninterrupted reads	32	Same	2 instructions per 3 cycles*	2 instructions per 3 cycles*
Sequential uninterrupted reads	16	Same	2 instructions per 6 cycles**	2 instructions per 6 cycles**
Non sequential and uninterrupted reads	32	Same	1 instructions per 7 cycles	1 instructions per 8 cycles
Non sequential uninterrupted reads	16	Same	1 instructions per 9 cycles	1 instructions per 10 cycles
<p>* First 48-bit instruction of a sequential read will take 7 cycles for CL = 2 and 8 cycles for CL = 3, thereafter it is two instructions per 3 cycles. The instruction available cycles will look like - 8, 9, 11, 12, 14, 15 ... (CL = 3)</p> <p>** In this case SDC has to fetch 3 data (16-bit) for each instruction. First 48-bit instruction of a sequential read will take 8 cycles for CL = 2 and 9 cycles for CL = 3, thereafter it is two instructions per 6 cycles. The instruction available cycles will look like - 9, 11, 15, 17, 21, 23, 27, 29 ... (CL = 3)</p>				

When executing from external asynchronous memory, instruction throughput depends on the settings of asynchronous memory such as the number of wait states, the ratio of core to peripheral clock and other settings. For details, please refer to the external port global control register (EPCTL), the AMICTLX register, and the SDCTL0 register in “External Port Registers” on page A-11.

Effect Latency

The total effect latency is a combination of the write effect latency (core access) plus the peripheral effect latency (peripheral specific). After the AMI/SDRAM registers are configured the effect latency is 1.5 PCLK cycles minimum and 2 PCLK cycles maximum.

After the external port register is configured the effect latency is 4 PCLK cycles. This is the valid for the worst case of core to SDRAM clock ratio of 1:4

Shared Memory

After the BMAX register is configured, to $\overline{\text{BRx}}$ high:

Minimum: $((\text{BMAX} + 2) \times \text{CLKIN}) + 2$ PCLK cycles

Maximum: $((\text{BMAX} + 3) \times \text{CLKIN}) + 1$ PCLK cycles

After the BUSLOCK bit in the SYCTL register is configured, to $\overline{\text{BRx}}$ low:

Minimum: PCLK/2 cycle

Maximum: one CLKIN cycle

Write Effect Latency

For details on write effect latency, see *SHARC Processor Programming Reference*.

Programming Models

The following sections provide information on the various programming models that are used through the external port interface.

External Port

The section describes software programming steps required for the successful operation of the external port.

AMI Initialization

After reset, the `SDCLK` is running with the default PLL settings. However, the AMI must be configured and initialized. In order to set up the AMI, use the following procedure. Note that the registers must be programmed in order.

1. Chose a valid `CCLK` to `SDCLK` clock ratio in the `PMCTL` register.
2. Assign external banks to the AMI using the `EPCTL` register (default).
3. Wait at least 8 `PCLK` cycles (effect latency).
4. Enable the global `AMIEN` bit and program the AMI control (`AMICTLx`) registers. (Define control settings for AMI based on `SDCLK` speed and asynchronous memory specifications.

The `AMIMS` and `AMIS` bits 1–0 of the AMI status register (`AMISTAT`) can be checked to determine the current state of the AMI.

DMA

The following sections describe the programming steps for different types of DMA transfers.

Standard DMA (ADSP-21367/8/9)

Use the following procedure to set up and run a standard DMA on the external port.

1. Configure the `AMICTLx` registers to enable the AMI and to set the desired wait states, data bus width, and so on. Configure the `SDCTL` registers to enable SDRAM, and to set the desired clock and timing settings, the data bus width, and other parameters.
2. Initialize the `IIEP`, `IMEP`, `ICEP`, `EIEP`, and `EMEP` registers.
3. If circular buffering is desired, program additional writes to the `ELEP` and `EBEP` registers.
4. Enable DMA using the `DMAEN` bit, and set the transfer direction using the `TRAN` bit in the `DMACx` registers. If scatter/gather DMA is desired, set the `TLEN` bit. It is advised that the DMA FIFOs are flushed using the `DFLSH` bit when DMA is enabled.

Once the DMA control register is initialized, the DMA engine fetches the DMA descriptors from the address pointed to by `CPEP`. Once the DMA descriptors are fetched then the DMA (or the tap list DMA) process starts. Once the DMA (or tap list DMA) is complete, the new DMA descriptors are loaded and the process is repeated until `CPEP = 0x0`. A DMA completion interrupt is generated at the end of each DMA block or at the end of entire chained DMA, depending on the `PCI` bit setting.

Chained DMA (ADSP-21367/8/9)

Use the following procedure to set up and run a chained DMA on the external port.

1. Clear the chain pointer register.
2. Configure the `AMICTLx` registers to enable the AMI, set the desired wait states, the data bus width, and so on. Configure the `SDCTL` register to enable the SDRAM, configure the desired clock and timing settings, data bus width, and other parameters.
3. Initialize the `CPEP` register and set the `PCI` bit if interrupts are required after the end of each DMA block.
4. If circular buffering is needed, then program additional writes to the `ELEP` and `EBEP` registers. Note that for non-circular chained DMA, the `ELEP` and `EBEP` registers are not part of the TCB. So if circular buffering is used with the chained DMA, all the DMA blocks must have same `ELEP` and `EBEP` values.
5. Enable DMA using the `DMAEN`, bit, set chaining using the `CHEN` bit. If circular buffering is required, set the `CBEN` bit in the `DMACx` registers. It is advised that programs flush the DMA FIFOs using the `DFLSH` bit when DMA is enabled.

Once the DMA control register is initialized, the DMA controller fetches the DMA descriptors from the address pointed to by the external port chain pointer register (`CPEP`).

Once the DMA descriptors are fetched, the normal DMA process starts. Upon completion, new DMA descriptors are loaded and the process is repeated until `CPEP = 0x0`. A DMA completion interrupt is generated at the end of each DMA block or at the end of an entire chained DMA, depending on the `PCI` bit setting.

Standard DMA (ADSP-21371/5)

Use the following procedure to set up and run a standard DMA on the external port.

1. Configure the `AMICTLx` registers to enable the AMI and to set the desired wait states, data bus width, and so on. Configure the `SDCTL` registers to enable SDRAM, and to set the desired clock and timing settings, the data bus width, and other parameters.
2. Initialize the `IIEP`, `IMEP`, `ICEP`, `EIEP`, and `EMEP` registers.
3. If circular buffering is desired, use the corresponding TCB storage.
4. If scatter/gather DMA is desired, program additional writes to the `TCEP` and `TPEP` registers.
5. Enable DMA using the `DMAEN` bit, and set the transfer direction using the `TRAN` bit in the `DMACx` registers. If scatter/gather DMA is desired, set the `TLEN` bit. It is advised that the DMA FIFOs are flushed using the `DFLSH` bit when DMA is enabled.

Once the DMA control register is initialized, the DMA engine fetches the DMA descriptors from the address pointed to by `CPEP`. Once the DMA descriptors are fetched then the DMA (or the tap list DMA) process starts. Once the DMA (or tap list DMA) is complete, the new DMA descriptors are loaded and the process is repeated until `CPEP = 0x0`. A DMA completion interrupt is generated at the end of each DMA block or at the end of entire chained DMA, depending on the `PCI` bit setting.

Chained DMA (ADSP-21371/5)

Use the following procedure to set up and run a chained DMA on the external port.

1. Clear the chain pointer register.
2. Configure the `AMICTLx` registers to enable the AMI, set the desired wait states, the data bus width, and so on. Configure the `SDCTL` register to enable the SDRAM, configure the desired clock and timing settings, data bus width, and other parameters.
3. Initialize the `CPEP` register and set the `PCI` bit if interrupts are required after the end of each DMA block. Set the `CPDR` bit if different DMA direction is required in conjunction with the `DFEN` bit in the `DMACx` register.
4. If circular buffering is needed, use the corresponding TCB storage.
5. Enable DMA using the `DMAEN` bit, set chaining using the `CHEN` bit. If circular buffering is required, set the `CBEN` bit in the `DMACx` registers. It is advised that programs flush the DMA FIFOs using the `DFLSH` bit when DMA is enabled.

Once the DMA control register is initialized, the DMA controller fetches the DMA descriptors from the address pointed to by the external port chain pointer register (`CPEP`).

Once the DMA descriptors are fetched, the normal DMA process starts. Upon completion, new DMA descriptors are loaded and the process is repeated until `CPEP = 0x0`. A DMA completion interrupt is generated at the end of each DMA block or at the end of an entire chained DMA, depending on the `PCI` bit setting.

Programming Models

Delay Line DMA

1. Configure the `AMICTLx` register with the desired wait states, enable AMI, data bus width and other parameters.
2. Initialize the `CPEP` register and set the `PCI` bit if interrupts are required after the end of each delay line DMA block.
3. Enable DMA (`DMAEN`), delay line DMA (`DLEN`), chaining (`CHEN`) if required in the `DMACx` register. Programs should flush the DMA FIFO (`DFLSH`) along with enabling the DMA. If circular buffering is required (which is normally the case) enable it by setting the `CBEN` bit.

Once the DMA control register is initialized the DMA engine fetches the DMA descriptors from the address pointed to by the `CPEP` register. Once the delay line DMA access is complete, the new DMA descriptors are loaded and the process is repeated until `CPEP = 0x0`. A DMA completion interrupt is generated at the end of each delay line DMA block or at the end of entire chained DMA, depending on the `PCI` bit setting.

 When delay line DMA is enabled with chaining, all the chained DMA blocks follow the delay line DMA access procedure. It is not possible to mix normal DMA with delay line DMA in chained DMA.

Disabling and Re-enabling DMA

Use the following programming model to disable the external port DMA during transfers.

1. Clear the `DMAEN` bit on the `DMACx` register.
2. Wait until the `EXTS` bit is 0.

3. Write 0x0 to the ICEP and DMAC_x registers. In cases where DMA is used without chaining, writing to ICEP is not required
4. Re initialize the required DMA registers, and enable the DMAC_x register while flushing the data/tap list FIFO.

Additional Information

1. If DMA is disabled in the middle of a data transfer, then DMA interrupts cannot be relied on.
2. A single DMA (no chaining) can be stopped midway by clearing the DMAEN bit in the DMAC_x register and then restarted from the point where it was stopped by re-enabling the DMAEN bit. This mode of inhibiting the DMA only works with single DMA. If a chained/delay line DMA is disabled by clearing DMAEN bit then the DMA should be reprogrammed again following the above programming model.
3. For a chained DMA, new TCB loading can be inhibited by clearing the CHEN bit while keeping all other control bits the same. The new TCB is loaded once CHEN bit is re-enabled. The TCB load which was happening when CHEN was cleared will complete.
4. Before initializing a chained DMA (including delay line) make sure that the ICEP and ECEP registers are zero.
5. The DMA parameter registers (except DMAC_x) should not be written to while chaining is occurring (the CHS bit is set), but any register can be read during chaining.
6. A zero count for the ICEP, RCEP and TCEP registers is forbidden. If a chain pointer with such a descriptor is programmed then the DMA might hang. So a read count zero or a write count zero for a delay line DMA is also forbidden.

SDRAM Controller

This section describes software programming steps required for the successful operation of the controller.

Power-Up Sequence

After reset, the `SDCLK` is running with the default PLL settings. However, the controller must be configured and initialized. In order to set up the controller and start the SDRAM power-up sequence for the SDRAMs, use the following procedure. Note that the registers must be programmed in order.

1. Chose a valid `CCLK` to `SDCLK` clock ratio in the `PMCTL` register.
2. Wait at least 15 core clock cycles until the new `SDCLK` frequency has been settled up correctly.
3. Assign external banks to controller in the `EPCTL` register.
4. Wait at least 8 cycles (effect latency).
5. Program the refresh counter in the `SDRRC` register.
6. Define global control for the controller and the SDRAM based on speed and SDRAM specifications in the `SDCTL` register.
7. Once the `SDPSS` bit in the `SDCTL` register is set to 1, the controller starts power-up sequence.

The SDRAM is ready for access.

The `SDRS` bit (bit 3) of the SDRAM control status register can be checked to determine the current state of the controller. If this bit is set, the SDRAM power-up sequence has not been initiated.

Output Clock Generator Programming Model

The following non VCO programming sequence may be used to change the output generator clock and the core-to-peripheral clock ratio (for example the SDRAM clock). Note that if your program is only changing the PLL output divider, programs do not need to wait 4096 `CLKIN` cycles (required only if the PLL multiplier or the `INDIV` bit is modified).

1. Disable the peripheral (SDRAM). Note that the peripherals cannot be enabled when changing clock ratio.
2. Select the PLL divider by setting the `PLLDx` bits (bits 6–7 in the `PMCTL` register).
3. Select the clock divider (`CCLK` to peripheral ratio) by setting the ratio bits (`PMCTL` register).
4. Wait 15 `CCLK` cycles. During this time, programs must not execute any valid instructions.
5. Enable the peripheral (SDRAM).

The new divisor ratios are picked up on the fly and the clocks smoothly transition to their new values after a maximum of 15 core clock `CCLK` cycles.

Listing 3-5. Example for Output Divider Management

```

ustat2 = dm(PMCTL);
bit set ustat2 DIVEN|PLLD4; /* set and enable output Divisor */
dm(PMCTL) = ustat2;

```

Self-Refresh Mode

The following steps are required when enter and releasing self-refresh mode.

1. Set the `SDSRF` bit to enter self-refresh mode
2. Poll the `SDSRA` bit in the SDRAM status register (`SDSTAT`) to determine if the SDRAM has already entered self-refresh mode.
3. Set the `DSDCTL` bit to freeze `SDCLK` (optional).
4. Self refresh mode-no activities on all SDRAM signals (clock optional).
5. Clear the `DSDCTL` bit to re-enable `SDCLK` (optional).
6. SDRAM access releases controller from self-refresh mode.

Changing the VCO Clock During Runtime

In previous SHARC models, only a hardware reset initiated another SDRAM power-up sequence. This is no longer the case since the PLL allows programs to change the output clocks during runtime.

All SDRAM timing specifications are normalized to the SDRAM clock. Since most of these are minimum specifications, (except t_{REF} , which is a maximum specification), a variation of the system clock violates a specific specification and causes a performance degradation for the other specifications.

The reduction of the system clock violates the minimum specifications, while increasing the system clock violates the maximum t_{REF} specification. Therefore, careful software control is required to adapt these changes. Therefore, the release from self-refresh mode should be a dummy read operation since it happens with the old frequency settings.

-  For most applications, the SDRAM power-up sequence and writing of the mode register needs to occur only once. Once the power-up sequence has completed, the SDPSS bit should not be set again unless a change to the mode register is desired.

The recommended procedure for changing the system frequency SDCLK is as follows.

1. Set the SDRAM to self-refresh mode by writing a 1 to the SDSRF bit of the SDCTL register.
2. Poll the SDSRA bit of SDSTAT register for self-refresh grant.
3. Execute the desired PLL programming sequence. (For more information, see “PLL Start-Up” on page 16-9.)
4. Wait 4096 CLKIN cycles ($\overline{\text{RESETOUT}}$ asserted) which indicates the PLL has settled to the new frequency.
5. Reprogram the SDRAM registers (SDRRC, SDCTL) with values appropriate to the new SDCLK frequency and assure that the SDSRF bit is set.
6. Bring the SDRAM out of self-refresh mode by performing a dummy read SDRAM access.
7. The controller now issues the commands PREA, 8xREF and MRS to initialize the SDRAM controller and the SDRAM to the new frequency.

The SDRAM device is now ready to be accessed.

Bus Synchronization with Shared SDRAM

In a system where multiple ADSP-21368 processors share a bank of SDRAM, the master processor’s SDRAM controller powers up the SDRAM. The master processor then periodically performs an auto-refresh

Programming Models

command as expected. When another ADSP-21368 arbitrates for and receives bus mastership, it assumes the responsibility for performing a pre-charge all command, followed by the auto-refresh command.

When a processor (other than the one responsible for power-up) receives bus mastership for the first time, the auto-refresh command is not performed. This can cause a delay of up to four times the value programmed between the execution of auto-refresh commands. Further, this delay can occur for each processor (other than the master) in the system.

To compensate for this delay, use the following procedure.

1. The processors, other than the one responsible for power-up, should wait for SDRAM power-up to complete. Flags or NOP-loops may be used to accomplish this.
2. After detecting that power-up is complete, and before performing any external data accesses, the processors (other than the power-up processor) should execute the following set of instructions to ensure that an auto-refresh command is executed.

```
r0 = dm(s dram_addr);    /* dummy access to grab the bus */
if not BM jump(pc,0);    /* wait for bus mastership */

ustat1 = dm(SDCTL);     /* Force an auto-refresh */

bit set ustat1 FARF;
dm(SDCTL) = ustat1;
```

After this code is executed, the processors in the system can start normal external accesses. These steps must be repeated when a processor is reset.

Bus Synchronization Notes

1. During normal operation, do not reset the current bus master (external hard reset) as this causes system synchronization problems. A few key signals are not driven during reset.
2. The `SDCLK` and `CLKIN` signals are used in the arbitration logic for the shared external bus. This logic requires that these clocks are rising edge aligned to function properly. Therefore, not all clock ratios are allowed in shared memory systems. The values of `PLLM` (PLL multiplier) and `PLLD` (PLL divider), which are set in the power management control register (`PMCTL`), need to be programmed such that the ratio (`PLLM/PLLD`) is an integer. If for example `PLLM = 25` and `PLLD = 2` the ratio is 12.5 (fractional) and will not work.
3. If the clock ratio from the PLL is changed by programming values of `PLLM` and/or `PLLD` in the `PMCTL` register, the `FSYNC` bit (bit 28 of `SYSCTL` register) should be set to re synchronize the shared memory system. This bit should be cleared after meeting the PLL settling time and the clock locks to the new ratio. [For more information, see “Power Management Control Registers \(PMCTL\)” on page A-7.](#)



Only core to SDRAM clock ratios of 1:2 and 1:4 are supported in shared memory systems for AMI or SDRAM (`SDCKR` bit) in the `PMCTL` register.

Conditional Bus Master Instruction

Conditional instructions can be written that depend upon whether the processor is the current bus master in a shared memory system. The assembly language mnemonic for this condition code is `BM`, and its complement is `Not BM` (not bus master). The `BM` condition indicates whether the processor is the current bus master. For more information, see the “Conditional Sequencing” section in the *SHARC Processor Programming Reference*, “Program Sequencer” chapter. To use the bus master condition, the condition code select (*CSEL*) field in the `MODE1` register must be zero or the condition is always evaluated as false.

External Instruction Fetch

The section describes the software programming steps needed for the successful operation of external instruction fetch through the external port. Note only the additional steps for code execution are illustrated. For timing related settings refer to [“Functional Description” on page 3-6](#).

AMI Configuration

For instruction fetch, the original (logical) address is multiplied by 3/2 and this address is translated depending on the bus width and `PKDIS` bit setting.

1. Assign external bank0 to AMI in the `EPCTL` register (default).
2. Wait at least 8 cycles (effect latency).
3. Enable the global `AMIEN` bit and clear (=0) the `PKDIS` bit.

SDRAM Configuration

For instruction fetch, the original (logical) address is multiplied by 3/2 and this address is translated depending on the bus width setting (`X16DE` bit).

1. Assign external bank 0 to SDRAM in the EPCTL register (default).
2. Wait at least 8 cycles (effect latency).
3. Configure the SDCTL and SDRRC registers accordingly.

External Memory Access Restrictions

The following external memory restrictions should be noted when writing programs.

1. The LW mnemonic is not applicable to external memory.
2. Conditional accesses to external memory should not be based on any of the FLAG pin status.
3. There is one cycle latency between a multiplier status change and an arithmetic loop abort. This extra cycle is a machine cycle and not the instruction cycle. Therefore, if there is a pipeline stall (due to external memory access etc.) then the latency does not apply.
4. A one cycle stall is generated whenever an instruction that contains a conditional external memory access is in the decode stage, where the evaluation of the condition is dependent on the outcome of the previous instruction in address stage. It applies to all kinds of conditions except for conditions based on FLAG status. The following is an example:

```
f12 = f11+f10;
if eq dm(ext) = r0;
```

ADSP-21367/8/9 Only

The following external memory restrictions should be noted when writing programs for the ADSP-21367/8/9 processors.

1. In a dual-data move instruction, both accesses should not be to external memory. Example:

Programming Models

```
R0 = dm(Ext_mem);  
R12 = pm(Ext_mem);
```

2. If there is an aborted conditional read from external memory or an interrupt during an external memory read, the processor generates a spurious read. This is an issue for FIFO devices or Flash memories, but is not an issue for standard memories.
3. Any sequence of IOP register access (read or write) followed by an external memory read, causes incorrect data to be read from external memory. To workaroud this restriction, separate the IOP and external memory access by adding a NOP instruction or any other instruction which is not either an IOP read/write, or an external memory read. Example:

```
R0 = dm(SPCTL2);  
NOP; /* fixes restriction */  
R12 = dm(Ext_mem);
```

ADSP-2137x Only

The following external memory restrictions should be noted when writing programs for the ADSP-2137x processors.

1. The `FLUSH CACHE` instruction has an effect latency of one instruction when executing program instructions from internal memory, and two instructions when executing from external memory.
2. When a new external memory instruction fetch occurs on the processor due to a jump from internal to external memory, or after a cache hit while executing instructions from external memory, there is one stall cycle present in the fetch1 stage. This stall avoids resource conflicts at the cache interface.

3. Any sequence of external memory access (read or write) followed by an IOP access, causes the IOP access to fail. To workaround this restriction, separate the external memory access and IOP access by adding a NOP instruction or any other instruction which is not either an IOP read/write, or an external memory access. Example:

```
R12 = dm(Ext_mem);  
NOP; /* fixes restriction */  
R0 = dm(SPCTL2);
```

4 MEMORY-TO-MEMORY PORT DMA

Table 4-1 lists the memory-to-memory port specifications. Note that the memory-to-memory port DMA module is used for internal memory transfers only and does not have any pins associated with it.

Table 4-1. MTM Port Specifications

Feature	Availability
Connectivity	
Multiplexed Pinout	No
SRU DAI Required	No
SRU DAI Default Routing	N/A
SRU2 DPI Required	No
SRU2 DPI Default Routing	N/A
Interrupt Control	Yes
Protocol	
Master Capable	Yes
Slave Capable	No
Transmission Simplex	Yes
Transmission Half Duplex	No
Transmission Full Duplex	No
Access Type	
Data Buffer	Yes
Core Data Access	No
DMA Data Access	Yes

Features

Table 4-1. MTM Port Specifications

Feature	Availability
DMA Channels	2
DMA Chaining	No
Boot Capable	No
Local Memory	No
Clock Operation	PCLK

Features

The memory-to-memory port incorporates:

- 2 DMA channels (read and write)
- Internal to internal transfers
- Data engine for DTCP applications (only for special part numbers)

Note that the SHARC supports another internal to internal DMA module (external port) which does support multiples DMA modes.

Register Overview

MTM Control Register (MTMCTL). Enables the read and write DMA channels across the internal memory. It does return status about the read or write DMA channel.

Clocking

The fundamental timing clock of the MTM is peripheral clock (PCLK).

Functional Description

The MTM module owns two DMA channels one for read and one for write including a data buffer which stores up to 2x32-bit data. After the DMA is configured, the read DMA channel fills the buffer with 64-bit data. After this transfer, the write DMA channel becomes active and empties the buffer according to its destination. This procedure is repeated until the DMA count is zero.

The memory-to-memory DMA controller is capable of transferring 64-bit bursts of data between internal memories.

 The MTM controller supports data in normal word address space only (32-bit). External to external DMA transfers are not supported.

Data Transfer

The memory-to-memory DMA controller is capable of transferring 64-bit bursts of data between internal memories.

Data Buffer

The `MTMFLUSH` bit in the `MTMCTL` register can be set to flush the FIFO and reset the read/write pointers. Setting and resetting the `MTMDEN` bit only starts and stops the DMA transfer, so it is always better to flush the FIFO along with `MTMDEN` reset.

Note that the `MTMFLUSH` bit should not be set along with the `MTMDEN` bit set. Otherwise the FIFO is continuously flushed leading to DMA data corruption.

Interrupts

DMA Transfer

Two DMA channels are used for memory-to-memory DMA transfers. The write DMA channel has higher priority over the read channel. The transfer is started by a write DMA to fill up the MTM buffer with a 2 x 32-bit word. Next, the buffer is read back over the same IOD bus to the new destination. With a two position deep buffer and alternate write and read access over the same bus, throughput is limited. The memory-to-memory DMA control register (MTMCTL) allows programs to transfer blocks of 64-bit data from one internal memory location to another. This register also allows verification of current DMA status during writes and reads.

Interrupts

There are two DMA channels; one write channel and one read channel. When the transmission of a complete data block is performed, each channel generates an interrupt that signals that the entire block of data has been processed. Note that the write and read interrupts (P15I, if the MTMI bit in the IMASK register is enabled) are very close to each other, so only one interrupt is triggered.

[Table 4-2](#) provides an overview of MTM interrupts.

Table 4-2. MTM Interrupt Overview

Interrupt Source	Interrupt Condition	Interrupt Completion	Interrupt Acknowledge	Default IVT
MTM (2 channels)	- WR DMA done - RD DMA done	Internal transfer completion	RTI instruction	P15I

MTM Throughput

Data throughput for internal to internal transfers is 12 PCLK cycles for 64-bit data.

Effect Latency

The total effect latency is a combination of the write effect latency (core access) plus the peripheral effect latency (peripheral specific).

Write Effect Latency

For details on write effect latency, see *SHARC Processor Programming Reference*.

MTM Effect Latency

After the MTM register is configured the effect latency is 1.5 PCLK cycles minimum and 2 PCLK cycles maximum.

Programming Model

This data transfer can be set up using the following procedure.

1. Program the DMA registers for both channels.
2. Set (=1) the MTMFLUSH bit (bit 1) in the MTMCTL register to flush the FIFO and reset the read/write pointers.
3. Set (=1) the MTMEN bit in the MTMCTL register.

A two-deep, 32-bit FIFO regulates the data transfer through the DMA channels.

Programming Model

5 PULSE WIDTH MODULATION

Pulse width modulation (PWM) is a technique for controlling analog circuits with a microprocessor's digital outputs. PWM is employed in a wide variety of applications, ranging from measurement to communications to power control and conversion. The interface specifications are shown in [Table 5-1](#).

Table 5-1. PWM Specifications

Feature	Availability
Connectivity	
Multiplexed Pinout	Yes, (External Port)
SRU DAI Required	No
SRU DAI Default Routing	N/A
SRU2 DPI Required	No
SRU2 DPI Default Routing	N/A
Interrupt Control	Yes
Protocol	
Master Capable	Yes
Slave Capable	N/A
Transmission Simplex	N/A
Transmission Half Duplex	N/A
Transmission Full Duplex	N/A

Features

Table 5-1. PWM Specifications (Cont'd)

Feature	Availability
Access Type	
Data Buffer	No
Core Data Access	N/A
DMA Data Access	N/A
DMA Channels	N/A
DMA Chaining	N/A
Boot Capable	N/A
Local Memory	No
Clock Operation	PCLK

Features

The following is a brief summary of the features of this interface.

- Four independent PWM units
- 2-phase output timing unit
- Center or edge aligned PWM
- Single or double update PWM timer period
- Output logic allows redirection of 2-phase output timing
- PWM units can operate synchronized to each other
- Complementary outputs allows bridge based applications

A block diagram of the module is shown in [Figure 5-1](#). The generation of the four output PWM signals on pins AH to BL is controlled by four primary blocks.

- The two-phase PWM timing unit, which is the core of the PWM controller, generates two pairs of complemented center based PWM signals.
- The emergency dead time insertion is implemented after the ‘ideal’ PWM output pair, including crossover, is generated.
- The output control unit allows the redirection of the outputs of the two-phase timing unit for each channel to either the high-side or the low-side output. In addition, the output control unit allows individual enabling/disabling of each of the four PWM output signals.
- The PWM interrupt controller generates an interrupt at the start of the PWM period which is shared for all modules.

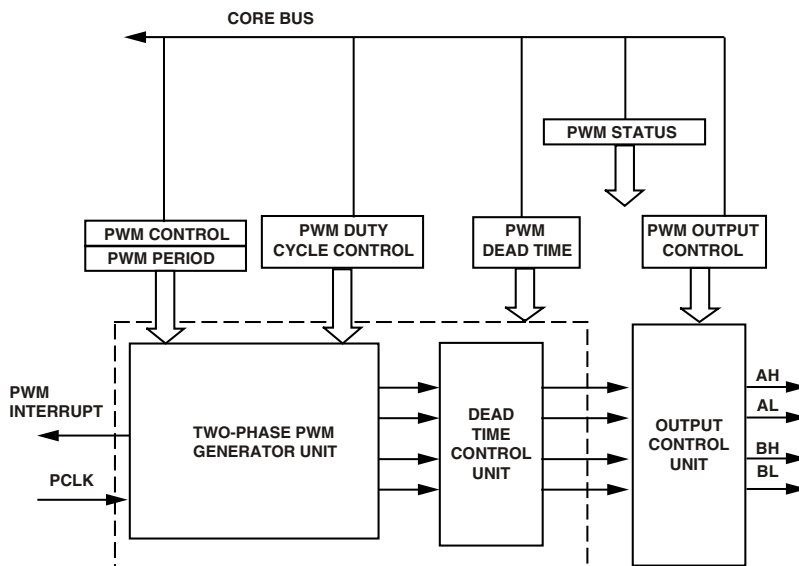

Figure 5-1. PWM Module Block Diagram

Pin Descriptions

The PWM module has four groups of four PWM outputs each, for a total of 16 PWM outputs. These outputs are described in [Table 5-2](#).

Table 5-2. PWM Pin Descriptions

Multiplexed Pin Name	Direction	Description
PWM_AH3-0	O	PWM output of pair A produce high side drive signals.
PWM_AL3-0	O	PWM output of pair A produce low side drive signals. Note in paired mode, this pin is the complement of AH3-0.
PWM_BH3-0	O	PWM output of pair B produce high side drive signals.
PWM_BL3-0	O	PWM output of pair A produce low side drive signals. Note in paired mode, this pin is the complement of BH3-0.

Multiplexing Scheme

By default the PWM output pins are disabled. To enable the PWM units refer to [Table 17-14 on page 17-29](#). [Table 5-3](#) shows the connection to the PWM outputs on the external port pins. [For more information, see “Pin Multiplexing” on page 17-27.](#)

Table 5-3. PWM Connections

PWM Unit	Pin Multiplexing
PWM0	EPDATA16=AL0 EPDATA17=AH0 EPDATA18=BL0 EPDATA19=BH0
PWM1	EPDATA20=AL1 EPDATA21=AH1 EPDATA22=BL1 EPDATA23=BH1

Table 5-3. PWM Connections (Cont'd)

PWM Unit	Pin Multiplexing
PWM2	EPDATA24=AL2 EPDATA25=AH2 EPDATA26=BL2 EPDATA27=BH2
PWM3	EPDATA28=AL3 EPDATA29=AH3 EPDATA30=BL3 EPDATA31=BH3

Register Overview

This section provides brief descriptions of the major registers. For complete register information, see [“Registers Reference” in Appendix A, Registers Reference](#).

- **PWM global control register (PWMGCTL)**. Enables or disables the four PWM groups simultaneously in any combination for synchronization between the PWM groups.
- **PWM global status register (PWMGSTAT)**. Provides the status of each PWM group.
- **PWM control registers (PWMCTLx)**. Used to set the operating modes of each PWM block. This register also allows programs to disable interrupts from individual groups.
- **PWM status registers (PWMSTATx)**. Report the phase and mode status for each PWM group.



The traditional read-modify-write operation to enable/disable a peripheral is different for the PWMs. [For more information, see “Global Control Register \(PWMGCTL\)” on page A-33.](#)

Clocking

The fundamental timing clock of the PWM controllers is peripheral clock (PCLK).

Functional Description

The individual elements shown in [Figure 5-1](#) are described in detail in the following sections.

Two-Phase PWM Generator

Each PWM group is able to generate complementary signals on two outputs in paired mode or each group can provide independent outputs in non-paired mode.

Switching Frequencies

The 16-bit read/write PWM period registers, PWMPERIOD3-0, control the PWM switching frequency.



The PWM generator does not support external synchronization mode.

The fundamental timing unit of the PWM controller is PCLK. Therefore, for a 200 MHz peripheral clock, the fundamental time increment is 5 ns. The value written to the PWMPERIODx register is effectively the number of PCLK clock increments in a PWM period (edge aligned mode) or in a half PWM period (center aligned mode) in half a PWM period.

Therefore, the PWM switching period, T_s , can be written as:

$$T_s = 2 \times \text{PWMTM} \times t_{\text{PCLK}} \text{ (center aligned)}$$

$$T_s = \text{PWMTM} \times t_{\text{PCLK}} \text{ (edge aligned)}$$

For example, for a 200 MHz $PCLK$ and a desired PWM center aligned switching frequency of 10 kHz ($T_s = 100 \mu s$), the correct value to load into the $PWMPERIODx$ register is:

$$PWMPERIOD = \frac{200 \times 10^6}{2 \times 10 \times 10^3} = 10000$$

The largest value that can be written to the 16-bit $PWMPERIODx$ register is $0xFFFF = 65,535$ which corresponds to a minimum PWM switching frequency of:

$$f_{(PWM),min} = \frac{200 \times 10^6}{2 \times 65535} = 1523 Hz$$



$PWMPERIOD$ values of 0 and 1 are not defined and should not be used when the PWM outputs or PWM sync is enabled.

Duty Cycles

The two 16-bit read/write duty cycle registers, $PWMA$ and $PWMB$, control the duty cycles of the four PWM output signals on the PWM pins. The two's-complement integer value in the $PWMA$ register controls the duty cycle of the signals on the PWM_{AH} and PWM_{AL} . The two's-complement integer value in the $PWMB$ register controls the duty cycle of the signals on PWM_{BH} and PWM_{BL} pins. The duty cycle registers are programmed in two's-complement integer counts of the fundamental time unit, $PCLK$, and define the desired on-time of the high-side PWM signal produced by the two-phase timing unit over half the PWM period. The duty cycle register range is from:

$$(-PWPERIOD \div 2 - PWMDT) \text{ to } (+PWPERIOD \div 2 + PWMDT)$$

which, by definition, is scaled such that a value of 0 represents a 50% PWM duty, cycle. The switching signals produced by the two-phase timing unit are also adjusted to incorporate the programmed dead time value in the $PWMDT$ register. The two-phase timing unit produces active low

Functional Description

signals so that a low level corresponds to a command to turn on the associated power device.

A typical pair of PWM outputs (in this case for PWM_AH and PWM_AL) from the timing unit are shown in [Figure 5-2](#) for operation in single-update mode. All illustrated time values indicate the integer value in the associated register and can be converted to time by simply multiplying by the fundamental time increment, ($PCLK$) and comparing this to the two's-complement counter. Note that the switching patterns are perfectly symmetrical about the midpoint of the switching period in single-update mode since the same values of the $PWMAX$, $PWMPERIODx$, and $PWMDTx$ registers are used to define the signals in both half cycles of the period.

Further, the programmed duty cycles are adjusted to incorporate the desired dead time into the resulting pair of PWM signals. As shown in [Figure 5-2](#), the dead time is incorporated by moving the switching instants of both PWM signals (PWM_AH and PWM_AL) away from the instant set by the $PWMAX$ registers. Both switching edges are moved by an equal amount ($PWMDT \times PCLK$) to preserve the symmetrical output patterns. Also shown is the PWM_PHASE bit of the $PWMSTAT$ register that indicates whether operation is in the first or second half cycle of the PWM period.

The resulting on-times (active low) of the PWM signals over the full PWM period (two half periods) produced by the PWM timing unit and illustrated in [Figure 5-2](#) may be written as:

The range of T_{AH} is:

$$[0 - 2 \times PWMPERIOD \times t_{PCLK}]$$

and the corresponding duty cycles are:

$$T_{AH} = (PWMPERIOD - 2 \times (PWMCHA + PWMDT)) \times t_{PCLK}$$

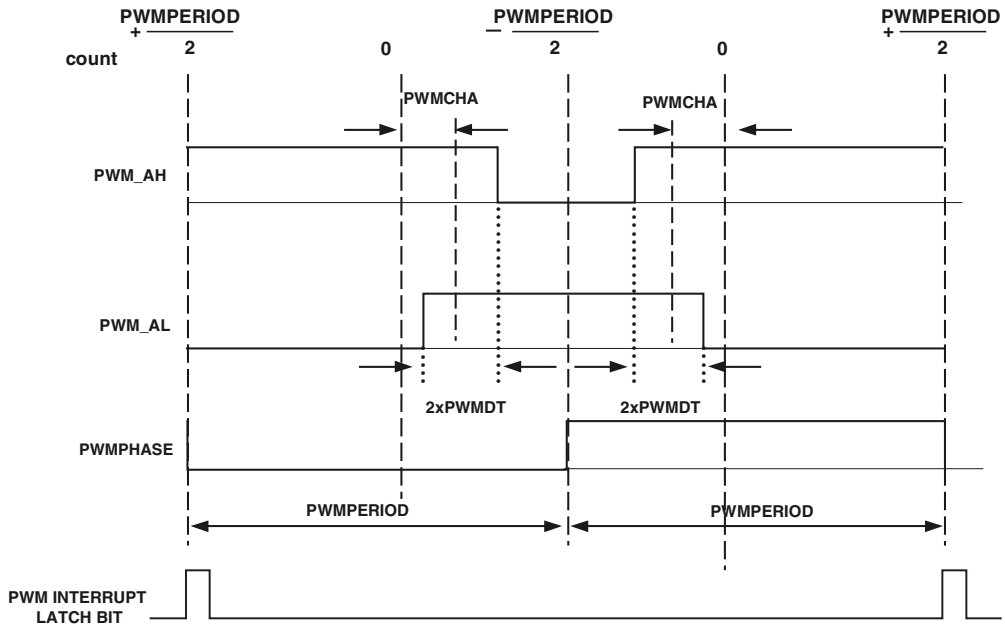

Figure 5-2. Center-Aligned Paired PWM in Single-Update Mode, Low Polarity

The range of T_{AL} is:

$$[0 - 2 \times PWMPERIOD \times t_{PCLK}]$$

and the corresponding duty cycles are:

$$d_{AH} = \frac{t_{AH}}{T_S} = \frac{1}{2} + \frac{PWMCHA - PWMDT}{PWMPERIOD}$$

$$d_{AL} = \frac{t_{AL}}{T_S} = \frac{1}{2} + \frac{PWMCHA - PWMDT}{PWMPERIOD}$$

The minimum permissible value of T_{AH} and T_{AL} is zero, which corresponds to a 0% duty cycle, and the maximum value is T_S , the PWM

Functional Description

switching period, which corresponds to a 100% duty cycle. Negative values are not permitted.

The output signals from the timing unit for operation in double-update mode are shown in [Figure 5-3](#). This illustrates a general case where the switching frequency, dead time, and duty cycle are all changed in the second half of the PWM period. The same value for any or all of these quantities can be used in both halves of the PWM cycle. However, there is no guarantee that a symmetrical PWM signal will be produced by the timing unit in this double-update mode. Additionally, [Figure 5-3](#) shows that the dead time is inserted into the PWM signals in the same way as in single-update mode.

In general, the on-times (active low) of the PWM signals over the full PWM period in double-update mode can be defined as:

$$T_S = (PWMPERIOD_1 + PWMPERIOD_2) \times t_{PCLK}$$

$$T_{AL} = \left(\frac{PWMPERIOD_1}{2} + \frac{PWMPERIOD_2}{2} - PWMCHA_1 - PWMCHA_2 - PWMDT_1 - PWMDT_2 \right) \times t_{PCLK}$$

$$T_{AH} = \left(\frac{PWMPERIOD_1}{2} + \frac{PWMPERIOD_2}{2} + PWMCHA_1 + PWMCHA_2 - PWMDT_1 - PWMDT_2 \right) \times t_{PCLK}$$

where subscript 1 refers to the value of that register during the first half cycle and subscript 2 refers to the value during the second half cycle. The corresponding duty cycles are:

$$d_{AL} = \frac{T_{AL}}{T_S} = \frac{1}{2} - \frac{(PWMCHA_1 + PWMCHA_2 + PWMDT_1 + PWMDT_2)}{(PWMPERIOD_1 + PWMPERIOD_2)}$$

$$d_{AH} = \frac{T_{AH}}{T_H} = \frac{1}{2} + \frac{(PWMCHA_1 + PWMCHA_2 - PWMDT_1 - PWMDT_2)}{(PWMPERIOD_1 + PWMPERIOD_2)}$$

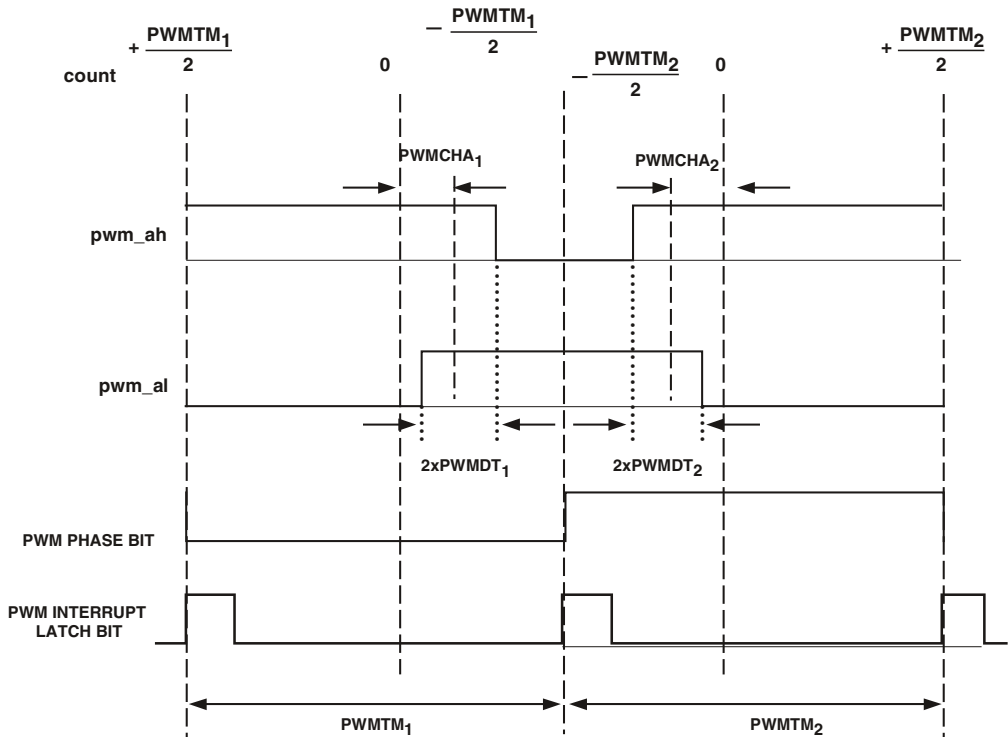

Figure 5-3. Center-Aligned Paired PWM in Double-Update Mode, Low Polarity

since for the general case in double-update mode, the switching period is given by:

$$T_S = (PWMPERIOD_1 + PWMPERIOD_2) \times t_{PCLK}$$

Again, the values of T_{AH} and T_{AL} are constrained to lie between zero and T_S . Similar PWM signals to those illustrated in [Figure 5-2](#) and [Figure 5-3](#) can be produced on the BH and BL outputs by programming the $PWMBx$ registers in a manner identical to that described for the $PWMAx$ registers.

Functional Description

Dead Time

The second important parameter that must be set up in the initial configuration of the PWM block is the switching dead time. This is a short delay time introduced between turning off one PWM signal (say AH) and turning on the complementary signal, AL. This short time delay is introduced to permit the power switch being turned off (AH in this case) to completely recover its blocking capability before the complementary switch is turned on. This time delay prevents a potentially destructive short-circuit condition from developing across the DC link capacitor of a typical voltage source inverter.

The 10-bit, read/write `PWMDT3-0` registers control the dead time. The dead time, T_d , is related to the value in the `PWMDTx` registers by:

$$T_d = PWMDT \times 2 \times t_{PCLK}$$

Therefore, a `PWMDT` value of `0x00A` (= 10), introduces a 200 ns delay between when the PWM signal (for example AH) is turned off and its complementary signal (AL) is turned on. The amount of the dead time can therefore be programmed in increments of $2 \times PCLK$ (or 10 ns for a 200 MHz peripheral clock). The `PWMDTx` registers are 10-bit registers, and the maximum value they can contain is `0x3FF` (= 1023) which corresponds to a maximum programmed dead time of:

$$T_{d,max} = 1023 \times 2 \times t_{PCLK} = 1023 \times 2 \times 10 \times 10^{-9} = 10.2 \mu s$$

This equates to an `PCLK` rate of 200 MHz. Note that dead time can be programmed to zero by writing 0 to the `PWMDTx` registers (see [“Pulse Width Modulation Registers” on page A-33](#)).

Output Control Unit

The `PWMSEG` register contains four bits (0 to 3) that can be used to individually enable or disable each of the 4 PWM outputs.

Output Enable

If the associated bit of the `PWMSEG` register is set (=1), then the corresponding PWM output is disabled, regardless of the value of the corresponding duty cycle register. This PWM output signal remains disabled as long as the corresponding enable/disable bit of the `PWMSEGx` register is set. In single update mode, changes to this register only become effective at the start of each PWM cycle. In double update mode, the `PWMSEG` register can also be updated at the mid-point of the PWM cycle.

 After reset, all four enable bits of the `PWMSEG` register are cleared so that all PWM outputs are enabled by default.

Output Polarity

The polarity of the generated PWM signals is programmed using the `PWM-POLARITY3-0` registers (see [“Pulse Width Modulation Registers” on page A-33](#)), so that either active high or active low PWM patterns can be produced. The polarity values can be changed on the fly if required, provided the change is done a few cycles before the next period change.

Complementary Outputs

The PWM controller can operate in paired or non paired mode (`PWMCTLx` register).

In non paired mode (default) both outputs (high and low side) are driven independently. Since paired mode drives the output logic of the PWM in a complementary fashion (low side = /high side), this feature may be useful in PWM bridge applications.

Crossover

The `PWMSEG3-0` registers contain two bits (`AHAL_XOVR` and `BHBL_XOVR`), one for each PWM output. If crossover mode is enabled for any pair of PWM signals, the high-side PWM signal from the timing unit (for example, `AH`)

Functional Description

is diverted to the associated low side output of the output control unit so that the signal ultimately appears at the AL pin.

The corresponding low side output of the timing unit is also diverted to the complementary high side output of the output control unit so that the signal appears at the AH pin. Following a reset, the two crossover bits are cleared so that the crossover mode is disabled on both pairs of PWM signals. Even though crossover is considered an output control feature, dead time insertion occurs after crossover transitions to eliminate shoot-through safety issues.

Note that crossover mode does not work if:

1. One signal of PWM_AL–PWM_AH or PWM_BL–PWM_BH is disabled.
2. PWM_AL and PWM_AH or PWM_BL and PWM_BH have different polarity settings from PWMPOLx registers.

In other words, both PWM_AL and PWM_AH or PWM_BL and PWM_BH should be enabled and both should have same polarity for proper operation of cross-over mode.

Emergency Dead Time for Over Modulation

The PWM timing unit is capable of producing PWM signals with variable duty cycle values at the PWM output pins. At the extreme side of the modulation process, settings of 0% and 100% modulation are possible. These two modes are termed full OFF and full ON respectively.



Full OFF and full ON over-modulation is entered by virtue of the commanded duty cycle values in conjunction with the setting in the PWMDTx registers. Settings that fall between the extremes are considered normal modulation. These settings are explained in more detail below.

Full On. The PWM for any pair of PWM signals operates in full on when the desired high side output of the two-phase timing unit is in the on state (low) between successive PWM interrupts.

Full Off. The PWM for any pair of PWM signals operates in full off when the desired high side output of the two-phase timing unit is in the off state (high) between successive `PWMSYNC` pulses.

Normal Modulation. The PWM for any pair of PWM signals operates in normal modulation when the desired output duty cycle is other than 0% or 100% between successive `PWMSYNC` pulses.

There are certain situations, when transitioning either into or out of either full on or full off, where it is necessary to insert additional *emergency dead time* delays to prevent potential *shoot-through conditions* in the inverter. These transitions are detected automatically and, if appropriate, the emergency dead time is inserted to prevent the shoot through conditions.

Inserting additional emergency dead time into one of the PWM signals of a given pair during these transitions is only needed if both PWM signals would otherwise be required to toggle within a dead time of each other. The additional emergency dead time delay is inserted into the PWM signal that is toggling into the on state. In effect, the turn on (if turning on during this dead time region), of this signal is delayed by an amount of $2 \times \text{PWMDT} \times \text{PCLK}$ from the rising edge of the opposite output. After this delay, the PWM signal is allowed to turn on, provided the desired output is still scheduled to be in the on state after the emergency dead time delay.

Figure 5-4 illustrates two examples of such transitions. In (a), when transitioning from normal modulation to full on at the half cycle boundary in double-update mode, no special action is needed. However in (b), when transitioning into full off at the same boundary, an additional emergency dead time is necessary. This inserted dead time is a little different to the normal dead time as it is impossible to move one of the switching events back in time because this would move the event into the previous

Functional Description

modulation cycle. Therefore, the entire emergency dead time is inserted by delaying the turn on of the appropriate signal by the full amount.

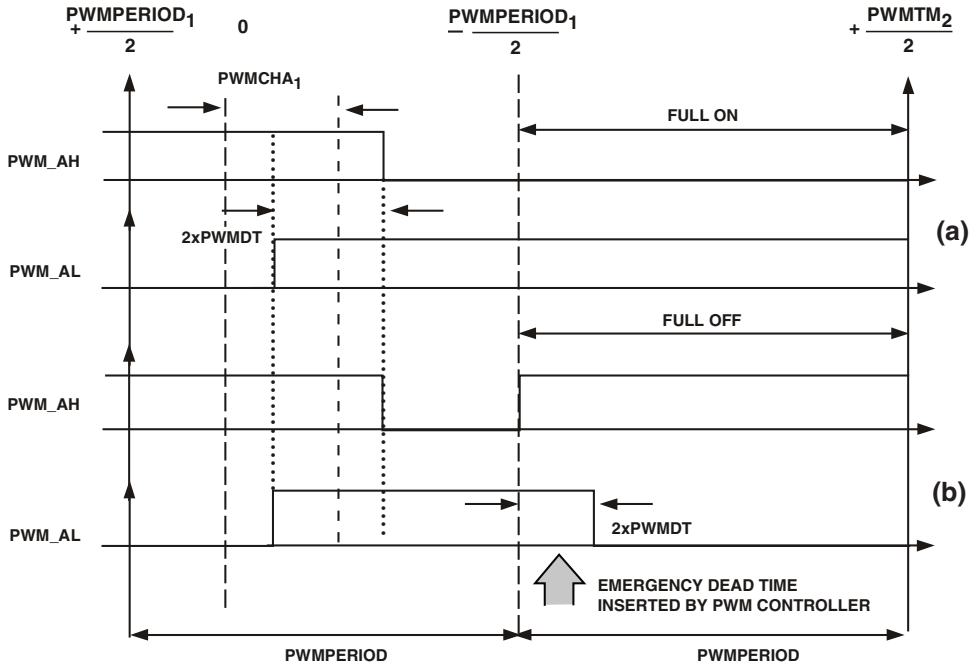

(a) TRANSITION FROM NORMAL MODULATION TO FULL-ON, AT HALF-CYCLE BOUNDARY IN DOUBLE UPDATE MODE, WHERE NO ADDITIONAL DEAD TIME IS NEEDED.
 (b) TRANSITION FROM NORMAL MODULATION TO FULL-OFF, AT HALF-CYCLE BOUNDARY IN DOUBLE UPDATE MODE, WHERE ADDITIONAL DEAD TIME IS INSERTED BY THE PWM CONTROLLER

Figure 5-4. Normal Modulation to Full ON to Full OFF Transition

Output Control Feature Precedence

The order in which output control features are applied to the PWM signal is significant and important. The following lists the order in which the signal features are applied to the PWM output signal.

1. Duty Cycle Generation
2. Crossover
3. Output Enable
4. Emergency Dead Time Insertion
5. Output Polarity

Operating Modes

The following sections provide information on the operating modes of the PWM module.

Waveform Modes

The PWM module can operate in both edge- and center-aligned modes. These modes are described in the following sections.

Edge-Aligned Mode

In edge-aligned mode, shown in [Figure 5-5](#), the PWM waveform is left-justified in the period window. A duty value of zero, programmed through the PWM_{MAX} registers, produces a PWM waveform with 50% duty cycle. For even values of period, the PWM pulse width is exactly $period/2$, whereas for odd values of period, it is equal to $period/2$ (rounded up). Therefore for a duty value programmed in two's-complement, the PWM pulse width is given by:

To generate constant logic high on PWM output, program the duty register with the value $\geq + period/2$.

To generate constant logic low on PWM output, program the duty register with the value $\geq - period/2$.

Operating Modes

For example, using an odd period of $p = 2n + 1$, the counter within the PWM generator counts as $(-n \dots 0 \dots +n)$. If the period is even ($p = 2n$) then the counter counts as $(-n+1 \dots 0 \dots n)$.

The PWM switching period time for edge aligned mode is:

$$T_s = t_{\text{PCLK}} \times \text{PWMPERIOD}.$$

For more information see [“Pulse Width Modulation Registers” on page A-33](#).

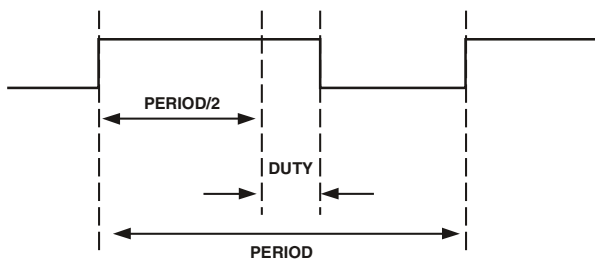

Figure 5-5. Edge Aligned PWM Wave with High Polarity

Center-Aligned Mode

Most of the following description applies to paired mode, but can also be applied to non-paired mode, the difference being that each of the four outputs from a PWM group is independent. Within center aligned mode, shown in [Figure 5-6 on page 5-20](#) there are several options to choose from.

Center-Aligned Single-Update Mode. Duty cycle values are programmable only once per PWM period, so that the resultant PWM patterns are symmetrical about the mid-point of the PWM period.

Center-Aligned Double-Update Mode. Duty cycle values are programmable only twice per PWM period. This second updating of the PWM registers is implemented at the mid-point of the PWM period, producing

asymmetrical PWM patterns that produce lower harmonic distortion in two-phase PWM inverters.

Center-Aligned Paired Mode. Generates complementary signals on two outputs.

Center-Aligned Non-Paired Mode. Generates independent signals on two outputs.

In paired mode, the two's-complement integer values in the 16-bit read/write duty cycle registers, $PWMAX$ and $PWMBx$, control the duty cycles of the four PWM output signals on the PWM_AL , PWM_AH , PWM_BL and PWM_BH pins respectively. The duty cycle registers are programmed in two's-complement integer counts of the fundamental time unit, $PCLK$ and define the desired on time of the high side PWM signal over one-half the PWM period.

The duty cycle register range is from $(-PWMPERIOD/2 - PWMDT)$ to $(+PWMPERIOD/2 + PWMDT)$, which, by definition, is scaled such that a value of 0 represents a 50% PWM duty cycle.

Each group in the PWM module (0–3) has its own set of registers which control the operation of that group. The operating mode of the PWM block (single or double update mode) is selected by the PWM_UPDATE bit (bit 2) in the PWM control ($PWMCTRL3-0$) registers. Status information about each individual PWM group is available to the program in the PWM status ($PWMSTAT3-0$) registers. Apart from the local control and status registers for each PWM group, there is a single PWM global control register ($PWMGCTL$) and a single PWM global status register ($PWMGSTAT$). The global control register allows programs to enable or disable the four groups in any combination, which provides synchronization across the four PWM groups.

The global status register shows the period completion status of each group. On period completion, the corresponding bit in the $PWMGSTAT$ register is set and remains sticky. The program first reads the global status register and clears all the intended bits by explicitly writing 1.

Operating Modes

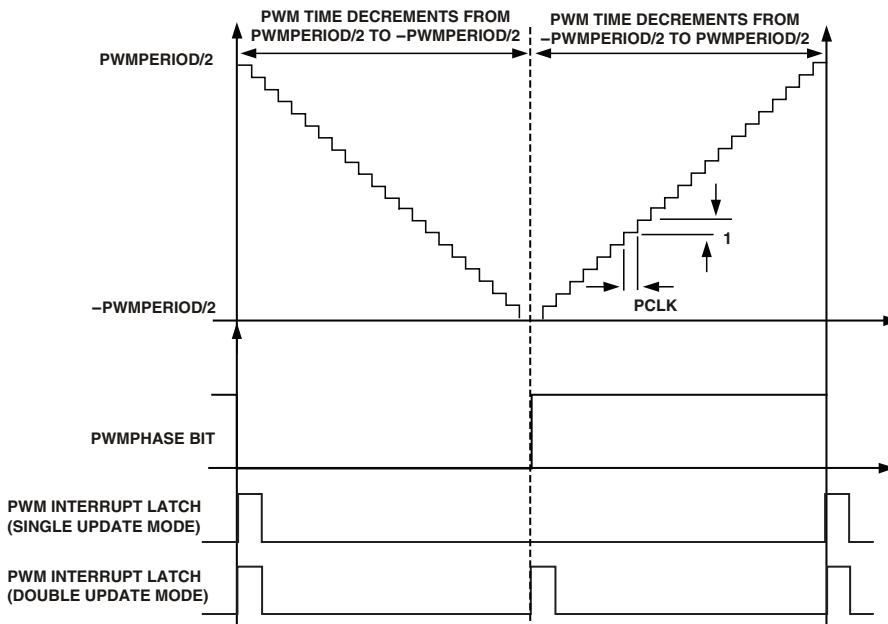

Figure 5-6. Operation of Internal PWM Timer (Center Aligned)

PWM Timer Edge Aligned Update

The internal operation of the PWM generation unit is controlled by the PWM timer which is clocked at the peripheral clock rate, $PCLK$. The operation of the PWM timer over one full PWM period is illustrated in [Figure 5-7](#). It can be seen that during the first half cycle, the PWM timer decrements from $PWMPERIOD/2$ to $-PWMPERIOD/2$ using a two's complement count.

At this point, the count direction changes and the timer continues to increment from $-PWMPERIOD/2$ to the $PWMPERIOD/2$ value.

Also shown in [Figure 5-7](#) are the PWM interrupt pulses for operation in edge aligned mode. An PWM interrupt is latched at the beginning of

every PWM cycle. Note that the `PWMPHASE` bit (`PWMSTAT` register) has no meaning in this mode and is always set.

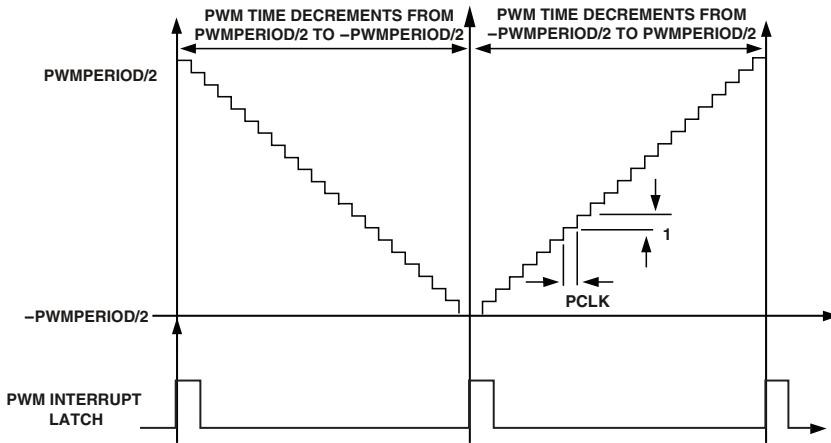

Figure 5-7. Operation of Internal PWM Timer (Edge Aligned)

Single Update Mode

In single update mode, a single PWM interrupt is produced in each PWM period. The rising edge of this signal marks the start of a new PWM cycle and is used to latch new values from the PWM configuration registers (`PWMTM` and `PWMDT`) and the PWM duty cycle registers (`PWMCHx`) into the two-phase timing unit. In addition, the `PWMSEG` register is also latched into the output control unit on the rising edge of the PWM interrupt latch pulse. In effect, this means that the characteristics and resultant duty cycles of the PWM signals can be updated only once per PWM period at the start of each cycle. The result is that PWM patterns that are symmetrical about the mid-point of the switching period are produced.

Operating Modes

Double Update Mode

In double update mode, there is an additional PWM interrupt latch pulse produced at the mid-point of each PWM period. The rising edge of this new PWM pulse is again used to latch new values of the PWM configuration registers, duty cycle registers and the `PWMSEG` register. As a result, it is possible to alter both the characteristics (switching frequency and dead time) as well as the output duty cycles at the mid-point of each PWM cycle. Consequently, it is possible to produce PWM switching patterns that are no longer symmetrical about the mid-point of the period (asymmetrical PWM patterns).

In double update mode, it may be necessary to know whether operation at any point in time is in either the first half or the second half of the PWM cycle. This information is provided by the `PWMPHASE` bit of the `PWMSTAT` register which is cleared during operation in the first half of each PWM period (between the rising edge of the original PWM interrupt latch pulse and the rising edge of the new PWM interrupt pulse introduced in double update mode). The `PWMPHASE` bit of the `PWMSTAT` register is set during operation in the second half of each PWM period. This status bit allows programs to make a determination of the particular half-cycle during implementation of the PWM interrupt service routine, if required.

The advantage of the double update mode is that the PWM process can produce lower harmonic voltages and faster control bandwidths are possible. However, for a given PWM switching frequency, the interrupts occur at twice the rate as in double update mode. Since new duty cycle values must be computed in each PWM interrupt service routine, there is a larger computational burden on the processor in the double update mode. Alternatively, the same PWM update rate may be maintained at half the switching frequency to give lower switching losses.

Effective Accuracy

The PWM has 16-bit resolution but accuracy is dependent on the PWM period. In single-update mode, the same values of $PWMA$ and $PWMB$ are used to define the on times in both half cycles of the PWM period. As a result, the effective accuracy of the PWM generation process is $2 \times PCLK$ (or 10 ns for a 200 MHz clock). Incrementing one of the duty cycle registers by one changes the resultant on time of the associated PWM signals by $2 \times PCLK$ in each half period (or $2 \times PCLK$ for the full period). In double-update mode, improved accuracy is possible since different values of the duty cycles registers are used to define the on times in both the first and second halves of the PWM period. As a result, it is possible to adjust the on-time over the whole period in increments of $PCLK$. This corresponds to an effective PWM accuracy of $PCLK$ in double-update mode (or 10 ns for a 200 MHz clock). The achievable PWM switching frequency at a given PWM accuracy is tabulated in [Table 5-4](#). In [Table 5-4](#), $PCLK = 200$ MHz.

Table 5-4. PWM Accuracy in Single- and Double-Update Modes

Resolution (bits)	Single-Update Mode PWM Frequency (kHz)	Double-Update Mode PWM Frequency (kHz)
8	$200 \text{ MHz} \div 2 \times 2^8 = 390.63$	$200 \text{ MHz} \div 2^8 = 781.25$
9	195.3	390.6
10	97.7	195.3
11	48.8	97.7
12	24.4	48.8
13	12.2	24.4
14	6.1	12.2

Interrupts

Synchronization of PWM Groups

The `PWMGCTL` register enables or disables the four PWM groups in any combination. This provides synchronization across the four PWM groups.

The `PWM_SYNC_ENx` bits in this register can be used to start the counter without enabling the outputs through `PWM_EN`. So when `PWM_ENx` is asserted, the 4 PWM outputs are automatically synced to the initially programmed period. In most cases, all `SYNC` bits can be initialized to zero, enabling the `PWM_ENx` bits of the four PWM groups at the same time synchronizes the four groups.

The PWM sync enable feature allows programs to enable the `PWM_SYNC_ENx` bits to independently start the main counter without enabling the corresponding PWM module using the `PWM_ENx` bits. To synchronize different groups, enable the corresponding group's `PWM_ENx` bit at the same time. In order to stop the counter both the `PWM_DISx` and `PWM_SYNC_DISx` bits should be set in this register.

Interrupts

The following sections provide information on the PWM and interrupt generation. [Table 5-5](#) provides an overview of PWM interrupts.

Table 5-5. PWM Interrupt Overview

Interrupt Source	Interrupt Condition	Interrupt Completion	Interrupt Acknowledge	Default IVT
PWM (Edge/center aligned, single/double update, 4 channels)	Period start		W1C (Write 1-to-clear) <code>PWMGSTAT + RTI</code> instruction	Need to route <code>PWMI (PICRx)</code> to any <code>PxxI</code>

Typically the PWM interrupt is used to periodically execute an interrupt service routine (ISR) to update the two PWM channel duties according to a control algorithm based on expected system operation. The PWM

interrupt can trigger the ADC to sample data for use during the ISR. During processor boot the PWM is initialized and program flow enters a wait loop. When a PWM interrupt occurs, the ADC samples data, the data is algorithmically interpreted, and new PWM channel duties are calculated and written to the PWM. More sophisticated implementations include different startup, runtime, and shutdown algorithms to determine PWM channel duties based on expected behavior and further features.

During initialization, the `PWMTM` register is written to define the PWM period and the `PWMCHx` registers are written to define the initial channel pulse widths. The PWM interrupt is assigned to one of the core's User

interrupts and is unmasked in the core. The `PWMSEG` and `PWMCHx` registers are also written, depending on the system configuration and modes. During the PWM interrupt driven control loop, only the `PWMCHx` duty values are typically updated. The `PWMSEG` register may also be updated for other system implementations requiring output crossover.

For interrupt execution, the specific `PWM_IRQEN` bit in the corresponding `PWMCTLx` register must be set including the `IMASK` or `LIRPTL` registers based on the programmable interrupt to be used.

Whenever a period starts, the PWM interrupt is generated. The interrupt latch bit is set 1 `PCLK` cycle after the PWM counter resumes. Since all four PWM units share the same interrupt vector, the interrupt service routine should read the `PWMGSTAT` register in order to determine the source of the interrupt. Next, the ISR needs to clear the status bits of the `PWMGSTAT` register by explicitly writing 1 into the status bit (`W1C`) as shown in [Listing 5-1](#).

Debug Features

Listing 5-1. Writing 1 Into the Status Bit

```
GPWM_ISR:
ustat2=dm(PWMGSTAT);      /* read global status reg */
bit tst ustat2 PWM_STAT2; /* test PWM2 status */
if tf jump PWM2_ISR;      /* jump to PWM2 routine */
instruction;
instruction;

PWM2_ISR:
r1=PWM_STAT2;
dm(PWMGSTAT)=r1;          /* W1C to clear PWM2 interrupt */
r10=dm(PWMCTL2);          /* dummy read for write latency */
instruction;
rti;
```

Debug Features

The following sections describe the status debug register and emulation considerations.

Status Debug Register

The module contains four debug status registers (PWMDBG3-0), which can be used for debug aid. Each register is available per unit. The registers return current status information about the AH, AL, BH, BL output pins.

Emulation Considerations

An emulation halt does not stop the PWM period counter.

Effect Latency

The total effect latency is a combination of the write effect latency (core access) plus the peripheral effect latency (peripheral specific).

Write Effect Latency

For details on write effect latency, see *SHARC Processor Programming Reference*.

PWM Effect Latency

After the PWM registers are configured the effect latency is 1 PCLK cycle minimum and 2 PCLK cycles maximum.

Effect Latency

6 DIGITAL APPLICATION/DIGITAL PERIPHERAL INTERFACES

The digital application interface (DAI) and the digital peripheral interface (DPI) are comprised of a groups of peripherals and their respective signal routing units (SRU and SRU2). The inputs and outputs of the peripherals are not directly connected to external pins. Rather, the SRUs connect the peripherals to a set of pins and to each other, based on a set of configuration registers. This allows the peripherals to be interconnected to suit a wide variety of systems. It also allows the SHARC processors to include an arbitrary number and variety of peripherals while retaining high levels of compatibility without increasing pin count.

The routing unit specifications are listed in [Table 6-1](#).

Table 6-1. Routing Unit Specifications

Feature	DAI	DPI
Pin Buffers		
Number	20	14
Input	Yes	Yes
Output	Yes	Yes
Open-drain	Yes	Yes
Three-state	No	No
High Impedance	Yes	Yes
Programmable Pull-up	Yes	Yes
I/O Level Status Register	Yes	Yes

Features

Table 6-1. Routing Unit Specifications

Feature	DAI	DPI
Interrupts		
Interrupt Control	Yes	Yes
Total Channels	32	12
Miscellaneous I/O channels	10	9
Peripheral Channels	22	3
Local Memory	No	No
Clock Operation	PCLK/4	PCLK/4

Features

The DAI/DPI incorporates a set of peripherals and a very flexible routing (connection) system permitting a large combination of signal flows. A set of DAI/DPI-specific registers make such design, connectivity, and functionality variations possible. All routing related to peripheral states for the DAI interface is specified using DAI/DPI registers. For more information on pin states, refer to [“I/O Pin Buffers” on page 6-7](#).

The DAI/DPI may be used to connect combinations of inputs to combinations of outputs. This function is performed by the SRU/SRU2 via memory-mapped control registers.

This *virtual connectivity* design offers a number of distinct advantages:

- Flexibility
- Increased numbers and kinds of configurations
- Connections can be made via software—no hard wiring is required



Inputs may only be connected to outputs.

Register Overview

The SRU for the DAI contains six register sets that are associated with the DAI groups.

Clock Routing Registers (SRU_CLKx). Associated with Group A, routes clock signals.

Serial Data Routing Registers (SRU_DATx). Associated with group B, routes data.

Frame Sync Routing Control Registers (SRU_FSx). Associated with group C, routes frame syncs or word clocks to the serial ports, the SRC, the S/PDIF, and the IDP.

Pin Signal Assignment Registers (SRU_PINx). Associated with group D, routes physical pins (connected to a bonded pad).

Miscellaneous Signal Routing Registers (SRU_MISCx). Associated with group E, allows programs to route to the DAI interrupt latch, PBEN input routing, or input signal inversion.

DAI Pin Buffer Enable Registers (SRU_PBENx). Associated with group F, Activate the drive buffer for each of the 20 DAI pins.

The SRU2 for DPI contains three register sets associated with the DPI groups.

Miscellaneous Signal Routing Registers (SRU2_INPUTx). Associated with group A, used to route the 14 external pin signals to the inputs of the other peripherals.

Pin Assignment Signal Routing (SRU2_PINx). Associated with group B routes pin output signals to the DPI pins.

Pin Enable Signal Routing (SRU2_PBENx). Associated with group C used to specify whether each DPI pin is used as an output or an input by setting the source for the pin buffer enable.

Clocking

The DAI/DPI registers are unique in that they work as groups to control other peripheral functions. The register groups and routings are described in detail in “DAI/DPI Group Routing” on page 6-18, “DAI Signal Routing Unit Registers” on page A-40 and “DPI Signal Routing Unit Registers” on page A-129.

Clocking

The fundamental timing clock of the DAI/DPI modules is peripheral clock/4 ($PCLK/4$).

Functional Description

Figure 6-1 shows how the DAI pin buffers are connected via the SRU. This allows for very flexible signal routing.

The DAI/DPI is comprised of five primary blocks:

- Peripherals (A/B/C) associated with DAI/DPI
- Signal Routing Units (SRU, SRU2)
- DAI/DPI I/O pin buffers
- Miscellaneous buffers
- Integrated interrupt control for DAI/DPI

The peripherals shown in Figure 6-1 can have up to three connections (if master or slave capable); one acts as signal input, one as signal output and the 3rd as output enable. The SRUs are based on a group of multiplexers which are controlled by registers to establish the desired interconnects. The DAI/DPI pin buffers have three signals which are used for input/output to/from off-chip world and the 3rd for output enable.

The miscellaneous buffers have an input and an output and are used for group interconnection.

Note that [Figure 6-1](#) is a simplified representation of a DAI system. In a real representation, the SRU and DAI would show several types of data being routed from several sources including the following.

- Serial ports (SPORT)
- Precision clock generators (PCG)
- Input data port (IDP)
- Asynchronous sample rate converters (SRC)
- S/PDIF transmitter
- S/PDIF receiver
- DAI Interrupts (Miscellaneous)

Similarly, the DPI pin buffers are connected via the SRU2. The DPI makes use of several types of data from a large variety of sources, including:

- Peripheral timers
- Serial Peripheral Interfaces (SPI)
- Precision clock generators (PCG)
- Universal asynchronous Rx/Tx ports (UART)
- Two-wire interface (TWI)
- GPIO flags (External Port)
- DPI Interrupts (Miscellaneous)

Functional Description

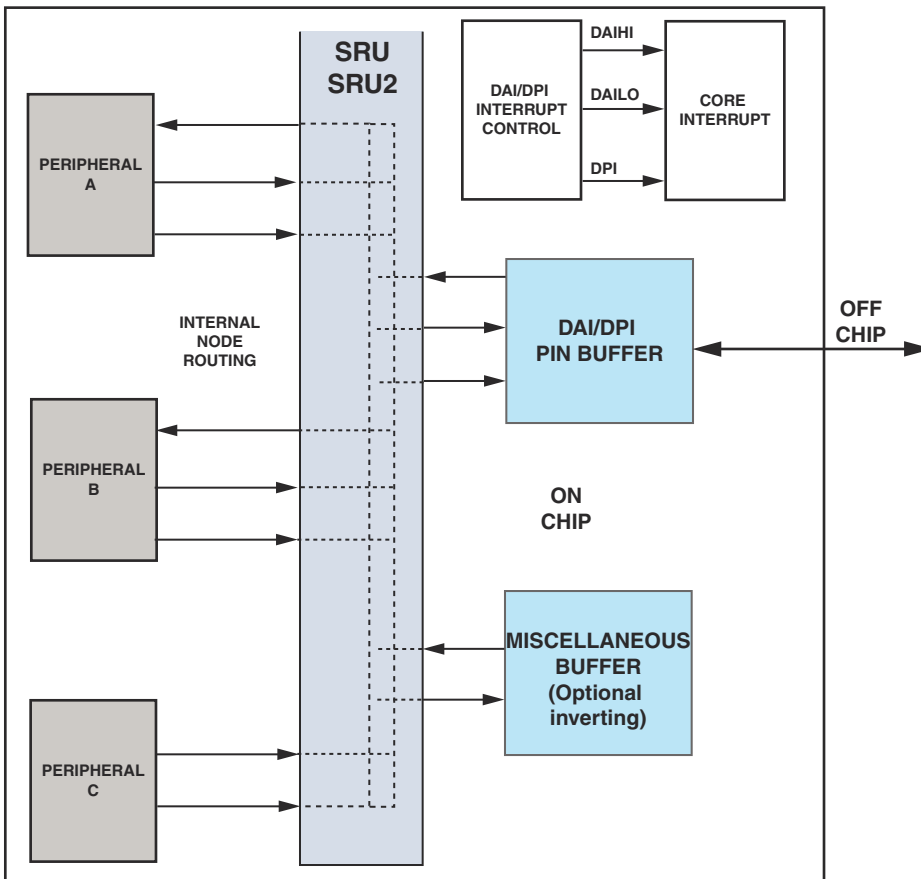



Figure 6-1. DAI/DPI Functional Block Diagram

 Note that the precision clock generator (units C/D) can be assigned to access DAI and/or DPI pins.

DAI/DPI Signal Naming Conventions

Each peripheral associated with the DAI/DPI does not have any dedicated I/O pins for off-chip communication. Instead, the I/O pin is only accessible in the chip internally and is known as an *internal node*. Every internal node of a DAI peripheral (input or output) is given a unique mnemonic. The convention is to begin the name with an identifier for the peripheral that the signal is coming to/from followed by the signal's function. A number is included if the DAI contains more than one peripheral type (for example, serial ports), or if the peripheral has more than one signal that performs this function (for example, IDP channels). The mnemonic always ends with `_I` if the signal is an input, or with `_O` if the signal is an output (Figure 6-2).

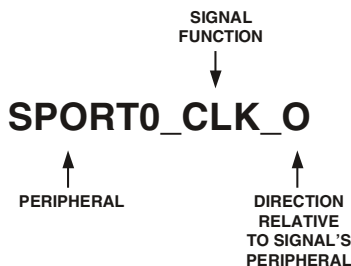

Figure 6-2. Example SRU Mnemonic

I/O Pin Buffers

Within the context of the SRU, physical connections to the DAI pins are replaced by a logical interface known as a *pin buffer*. This is a three terminal active device capable of sourcing/sinking output current when its driver is enabled, and passing external input signals when disabled. Each pin has an input, an output, and an enable as shown in Figure 6-3. The inputs and the outputs are defined with respect to the pin, similar to a peripheral device. This is consistent with the SRU naming convention.

Functional Description

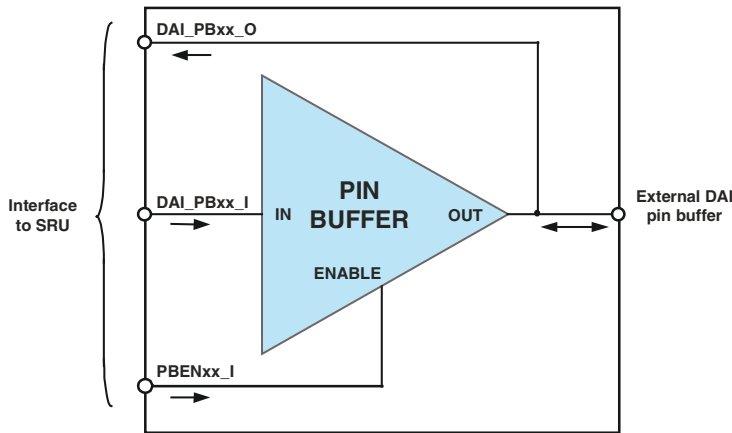

Figure 6-3. Pin Buffer Example

The notation for pin input and output connections can be quite confusing at first because, in a typical system, a pin is simply a wire that connects to a device. The manner in which the pins are routed within the SRU requires additional nomenclature. The pin interface's input may be thought of as the input to a buffer amplifier that can drive a load on the physical external lead. The pin interface enable is the input signal that enables the output of the buffer by turning it on when its value is logic high, and turning it off when its value is logic low.

When the pin enable is asserted, the pin output is logically equal to pin input, and the pin is driven. When the pin enable is deasserted, the output of the buffer amplifier becomes high impedance. In this situation, an external device may drive a level onto the line, and the pin is used as an input to the processors.

Pin Buffers as Signal Output

In a typical embedded system, most pins are designated as either inputs or outputs when the circuit is designed, even though they may have the ability to be used in either direction. Each of the DAI pins can be used as

either an output or an input. Although the direction of a DAI pin is set simply by writing to a memory-mapped register, most often the pin's direction is dictated by the designated use of that pin. For example, if the DAI pin were to be hard wired to only the input of another interconnected circuit, it would not make sense for the corresponding pin buffer to be configured as an input. Input pins are commonly tied to logic high or logic low to set the input to a fixed value. Similarly, setting the direction of a DAI pin at system startup by tying the pin buffer enable to a fixed value (either logic high or logic low) is often the simplest and cleanest way to configure the SRU.

When the DAI pin is to be used only as an output, connect the corresponding pin buffer enable to logic high as shown in Figure 6-4. This enables the buffer amplifier to operate as a current source and to drive the value present at the pin buffer input onto the DAI pin and off-chip. When the pin buffer enable ($PBEN_{xx_I}$) is set ($= 1$), the pin buffer output (PB_{xx_O}) is the same signal as the pin buffer input (PB_{xx_I}), and this signal is driven as an output.

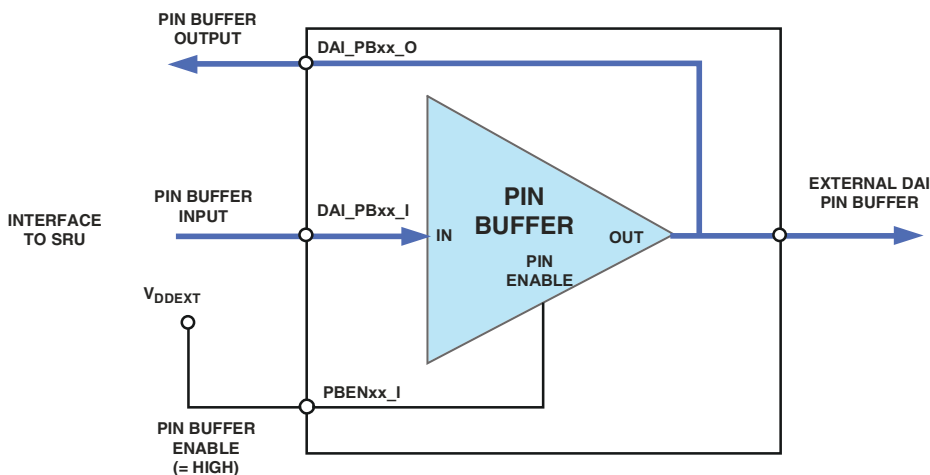

Figure 6-4. Pin Buffer as Output

Functional Description

Pin Buffers as Signal Input

When the DAI pin is to be used only as an input, connect the corresponding pin buffer enable to logic low as shown in Figure 6-5. This disables the buffer amplifier and allows an off-chip source to drive the value present on the DAI pin and at the pin buffer output. When the pin buffer enable ($PBEN_{xx_I}$) is cleared ($= 0$), the pin buffer output (PB_{xx_0}) is the signal driven onto the DAI pin by an external source, and the pin buffer input (PB_{xx_I}) is not used.

i Although not strictly necessary, it is recommended programming practice to tie the pin buffer input to logic low whenever the pin buffer enable is tied to logic low (Figure 6-5 and Figure 6-6).

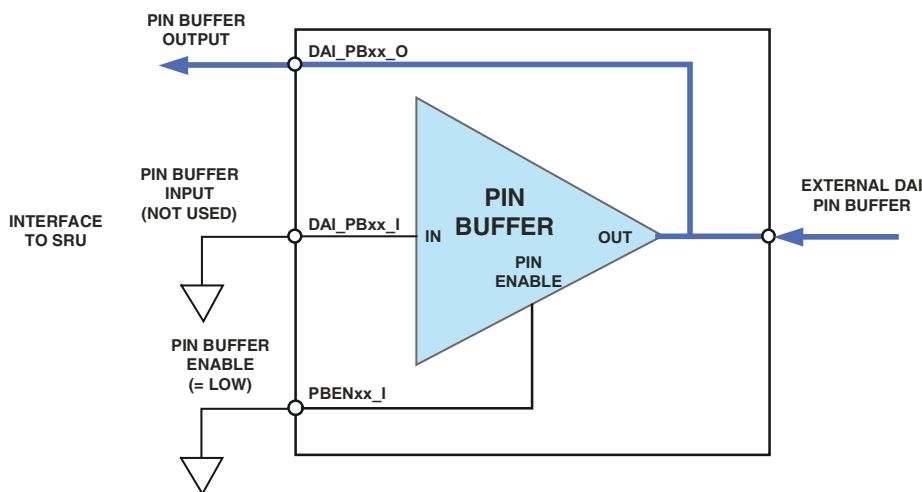

Figure 6-5. Pin Buffer as Input

By default, some pin buffer enables are connected to SPORT pin enable signals that may change value. Tying the pin buffer input low decouples the line from irrelevant signals and can make code simpler to debug. It also ensures that no voltage is driven by the pin if a bug in your code accidentally asserts the pin enable.

Pin Buffers as Open Drain

For peripherals like the TWI and SPI (multi processing), the bus protocol requires the pin drivers to work in open drain mode (Figure 6-6) for transmit and receive operation. The signal input of the assigned pin buffer is tied low. The peripheral's data output signal is connected to the `PBEN` signal. In open drain mode, if `PBEN = low`, the level on the pin is depending on the bus activities. If `PBEN = high`, the driver is conducting (input always low level) and ties the bus low level. Note that for the SPI the `ODP` bit in the `SPICTL` register must be enabled.

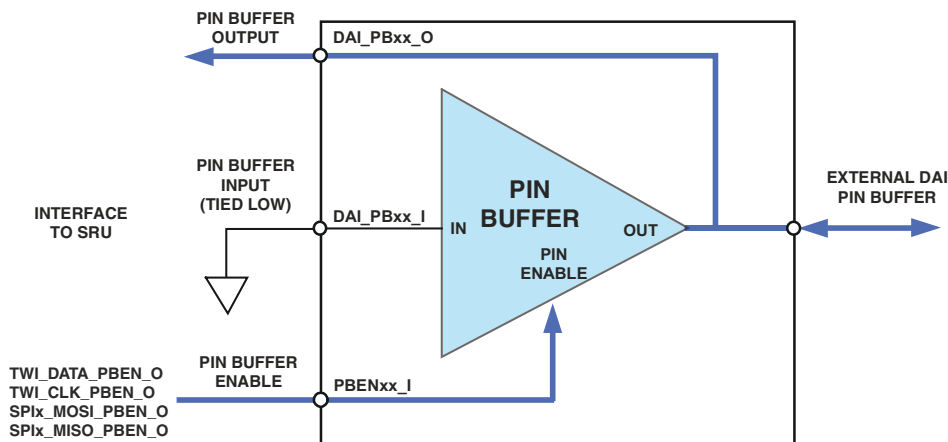

Figure 6-6. Pin Buffer as Open Drain



In open drain mode the data output signal is the peripheral's `PBEN_0` signal

Programmable Pull-Up Resistors

The pin buffer allows systems to attach a pull-up connected to the pad (high impedance) or disconnected (three state). This is controlled through the `DAI_PULLUP` and `DPI_PULLUP` registers.

Functional Description

DAI/DPI Pin Buffer Status

The signal levels on the DAI/DPI pins can be read with the DAI/DPI_PIN_STAT registers. This allows conditions like for example:

```
ustat2=dm(DAI_PIN_STAT);  
bit tst ustat2 DAI_PB10;  
if TF jump DAI_PB10_high;
```

Unused DAI/DPI Pins

If a DAI/DPI pin is not being used, its pin enable (for example DAI_PBENxx_I) and its input (DAI_PBxx_I) for its pin buffer should be connected to low and its associated bit in the DAI/DPI_PIN_PULLUP register should be set (= 1) to enable a pull-up resistor for that pin.

Miscellaneous Buffers

The miscellaneous buffers (Figure 6-7) are used to interconnect signals from different routing groups. These buffers have the following characteristics.

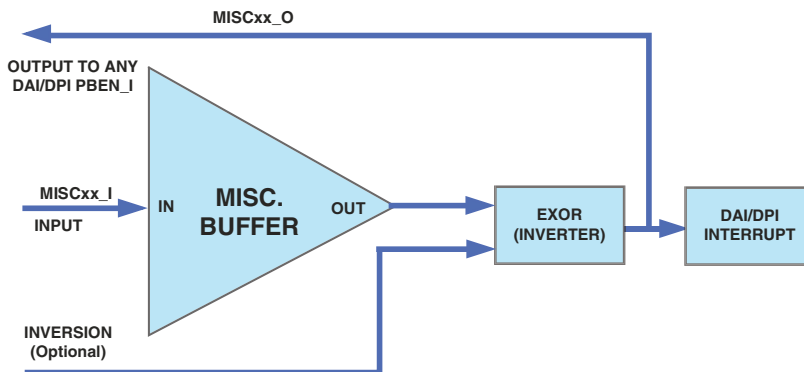

Figure 6-7. Miscellaneous Buffer

1. Only for internal connections, no pin buffer enable required.
2. MISC_{xx}_0 output always feeds DAI/DPI interrupt latch register and group F (DAI) and group C (DPI) to route to any DAI/DPI PBEN_I signal.
3. MISC_{xx}_I input sources collected from different groups.
4. Some buffers allow signal inversion.

The miscellaneous buffers acts as intermediate buffer connections between the peripheral's source node and the pin buffer enable destination node. This allows for routing that are not possible among a single group.

 The miscellaneous buffer allows interconnects which are not supported within a DAI/DPI routing group.

Table 6-2 and Table 6-3 provide routing options for the DAI and DPI miscellaneous buffers. Note that while the Interrupt and Miscellaneous Inputs have different naming conventions, they are the same physical input field.

Table 6-2. Miscellaneous DAI Buffer Routing

Register	Inputs		Outputs		
	Interrupt	Miscellaneous	Interrupt Trigger	Signal Inversion	DAI_PBEN _{xx} _I Routing
SRU_EXT_-MISCA	DAI_INT_28_I	MISCA0_I	Yes	No	Yes
	DAI_INT_29_I	IMISCA1_I	Yes	No	Yes
	DAI_INT_30_I	MISCA2_I	Yes	No	Yes
	DAI_INT_31_I	MISCA3_I	Yes	No	Yes
		MISCA4_I	No	Yes	Yes
		MISCA5_I	No	Yes	Yes
SRU_EXT_-MISCB	DAI_INT_22_I		Yes	No	Yes
	DAI_INT_23_I		Yes	No	Yes
	DAI_INT_24_I		Yes	No	Yes
	DAI_INT_25_I		Yes	No	Yes
	DAI_INT_26_I		Yes	No	Yes
	DAI_INT_27_I		Yes	No	Yes

Functional Description

Table 6-3. Miscellaneous DPI Buffer Routing

Register	Inputs		Outputs		
	Interrupt	Miscellaneous	Interrupt Trigger	Signal Inversion	DPI_PBEN _{xx} _I Routing
SRU2_INPUT4	DPI_INT_05_I	MISCB0_I	Yes	No	Yes
	DPI_INT_06_I	MISCB1_I	Yes	No	Yes
	DPI_INT_07_I	MISCB2_I	Yes	No	Yes
SRU2_INPUT5	DPI_INT_08_I	MISCB3_I	Yes	No	Yes
	DPI_INT_09_I	MISCB4_I	Yes	No	Yes
	DPI_INT_10_I	MISCB5_I	Yes	No	Yes
	DPI_INT_11_I	MISCB6_I	Yes	No	Yes
	DPI_INT_12_I	MISCB7_I	Yes	No	Yes
	DPI_INT_13_I	MISCB8_I	Yes	No	Yes

DAI/DPI Peripherals

There are two categories of peripherals associated with the DAI and DPI. These are described in the following sections.

Output Signals With Pin Buffer Enable Control

Many peripherals within the DAI/DPI that have bidirectional pins generate a corresponding pin enable signal. Typically, the settings within a peripheral's control registers determine if a bidirectional pin is an input or an output, and is then driven accordingly.

 Both the peripheral control registers and the configuration of the SRU can effect the direction of signal flow in a pin buffer.

from an external perspective for example, when a serial port (SPORT) is completely routed off-chip, it uses four pins—clock, frame sync, data channel A, and data channel B. Because all four of these pins comprise the interface that the serial port presents to the SRU, there are a total of 12 connections as shown in [Figure 6-8](#).

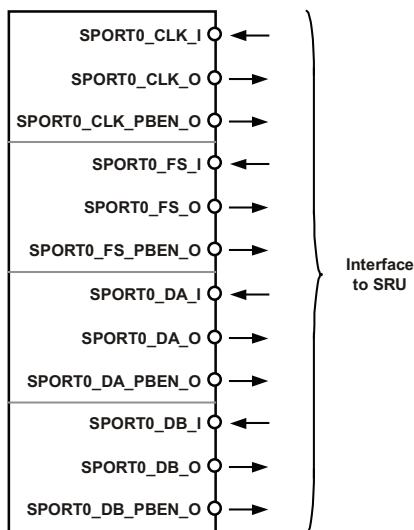

Figure 6-8. SRU Connections for SPORT0

For each bidirectional line, the SPORT provides three separate signals. For example, a SPORT clock has three separate SRU connections (instead of one physical pin):

- input clock to the SPORT ($SPORT_x_CLK_I$)
- output clock of the SPORT ($SPORT_x_CLK_O$)
- output enable clock of the SPORT ($SPORT_x_CLK_PBEN_O$)

If the SPORT operates in master mode, the $SPORT_x_CLK_O$ and $SPORT_x_CLK_PBEN$ signals are automatically driven. If operating in slave mode, the $SPORT_x_CLK_O$ and $SPORT_x_CLK_PBEN$ signals are automatically disabled and the $SPORT_x_CLK_I$ signal expects an external clock.



The input and output signal pair is never used simultaneously. The pin enable signal dictates which of the two SPORT lines appear at the DAI pin at any given time. By connecting all three signals through the SRU, the standard SPORT configuration registers

Functional Description

behave as documented in [Chapter 7, Serial Ports](#). The SRU then becomes transparent to the peripheral. [Figure 6-8](#) demonstrates SPORT0 properly routed to DAI pins one through four; although it can be equally well routed to any of the 20 DAI pins.

Output Signals Without Pin Buffer Enable Control

Some peripherals have signal outputs without automated pin buffer control enable (PDAP_STRB_0, MISCx_0, BLK_START_0).

The operation of these peripherals is simplified as the routing to a DAI/DPI pin buffer enable input requires a static high from the SRU. In order to disable the pin buffer output, software must clear the pin buffer enable input accordingly.

Signal Routing Units (SRUs)

The following sections provide more detail specific to the SRUs.

Signal Routing Matrix by Groups

The SRU can be likened to a set of patch bays, which contains a bank of inputs and a bank of outputs. For each input, there is a set of permissible output options. Outputs can feed to any number of inputs in parallel, but every input must be patched to exactly one valid output source. Together, the set of inputs and outputs are called a group. The signal's inputs and outputs that comprise each group all serve similar purposes. They are compatible such that almost any output-to-input patch makes functional sense. With the grouping, the multiplexing scheme becomes highly efficient since it wouldn't make sense for instance to route a frame sync signal to a data signal.

The SRU for the DAI contains six groups that are named sequentially A through F. Each group routes a unique set of signals with a specific purpose as shown below.

- Group A routes clock signals
- Group B routes serial data signals
- Group C routes frame sync signals
- Group D routes pin signals
- Group E routes miscellaneous signals
- Group F routes pin output enable signals

Together, the SRU's six groups include all of the inputs and outputs of the DAI peripherals, a number of additional signals from the core, and all of the connections to the DAI pins.

The SRU2 for DPI contains three groups that are named sequentially A through C. Each group routes various signals with a specific purpose:

- Group A routes miscellaneous signals
- Group B routes pin output signals
- Group C routes pin output enable signals



Unlike the SRU in the DAI module, all types of functionality such as clock and data are merged into the same group in the DPI peripheral.

Note that it is not possible to connect a signal in one group directly to signal in a different group (analogous to wiring from one patch bay to another). However, group D (DAI) or group B (DPI) is largely devoted to routing in this vein.

Functional Description

DAI/DPI Group Routing

Each group has a unique encoding for its associated output signals and a set of configuration registers. For example, DAI group A is used to route clock signals. The memory-mapped registers, `SRU_CLKx`, contain bit fields corresponding to the clock inputs of various peripherals. The values written to these bit fields specify a signal source that is an output from another peripheral. All of the possible encodings represent sources that are clock signals (or at least could be clock signals in some systems). [Figure 6-9](#) diagrams the input signals that are controlled by the group A register, `SRU_CLKx`. All bit fields in the SRU configuration registers correspond to inputs. The value written to the bit field specifies the signal source. This value is also an output from some other component within the SRU.

The SRU is similar to a set of patch bays. Each bay routes a distinct set of outputs to compatible inputs. These connections are implemented as a set of memory-mapped registers with a bit field for each input. The outputs are implemented as a set of bit encodings. Conceptually, a patch cord is used to connect an output to an input. In the SRU, a bit pattern that is associated with a signal output (shown in [Figure 6-9](#)) is written to a bit field corresponding to a signal input.

The same encoding can be written to any number of bit fields in the same group. It is not possible to run out of patch points for an output signal.

Just as group A routes clock signals, each of the other groups route a collection of compatible signals. Group B routes serial data streams while group C routes frame sync signals. Group D routes signals to pins so that they may be driven off-chip. Note that all of the groups have an encoding that allows a signal to flow from a pin output to the input being specified by the bit field, but group D is required to route a signal to the pin input. Group F routes signals to the pin enables, and the value of these signals determines if a DAI pin is used as an output or an input. These groups are described in more detail in the following sections.

Digital Application/Digital Peripheral Interfaces

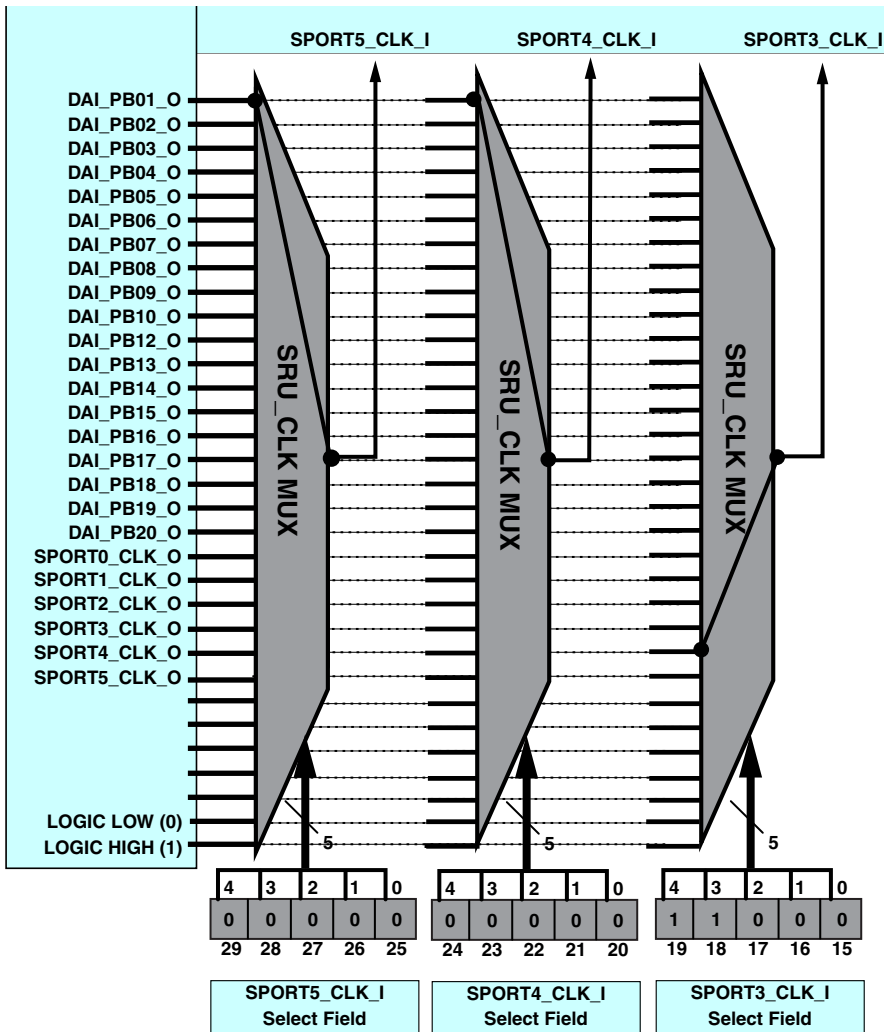

Figure 6-9. Valid DAI Clock Routing (SPORTs)

Functional Description

Rules for SRU Connections

There are two rules which apply to all routing:

1. Each input must connect to exactly one output
2. An output can feed any number of inputs

As an example from [Figure 6-9](#):

- DAI_PB01_0 is routed to SPORT5_CLK_I
- DAI_PB01_0 is routed to SPORT4_CLK_I
- SPORT4_CLK_0 is routed to SPORT3_CLK_I



Inputs may only be connected to outputs.

Making SRU Connections

In this section, three types of SRU routing are demonstrated.

1. [Listing 6-1](#) and [Figure 6-10](#) show the SRU connection between the DAI and pin buffers.
2. [Listing 6-2 on page 6-22](#) and [Figure 6-11 on page 6-22](#) show the SRU connection between the DAI pin buffers and SPORTs.
3. [Listing 6-3 on page 6-23](#) and [Figure 6-12 on page 6-23](#) show SRU connection from the SPORT/PCG to the MISC/DAI pin buffers.



These examples use a macro which is provided by the CrossCore or VisualDSP++ tools. Also see [“Programming Model” on page 6-42](#).

Listing 6-1. SRU Connection Between DAI Pin Buffers

```
SRU(HIGH, PBEN03_I);    // DAI pin 3 output
nop;
SRU(LOW, PBEN14_I);    // DAI pin 14 input
```

Digital Application/Digital Peripheral Interfaces

```
nop;  
SRU(LOW, DAI_PB14_I); // DAI pin 14 input level low  
nop;  
SRU(DAI_PB14_0, DAI_PB03_I); // connect DAI pin 14 to DAI pin 3  
nop;  
SRU(DAI_PB14_0, DAI_INT_22_I); // connect DAI pin 14 to DAI  
interrupt 22
```

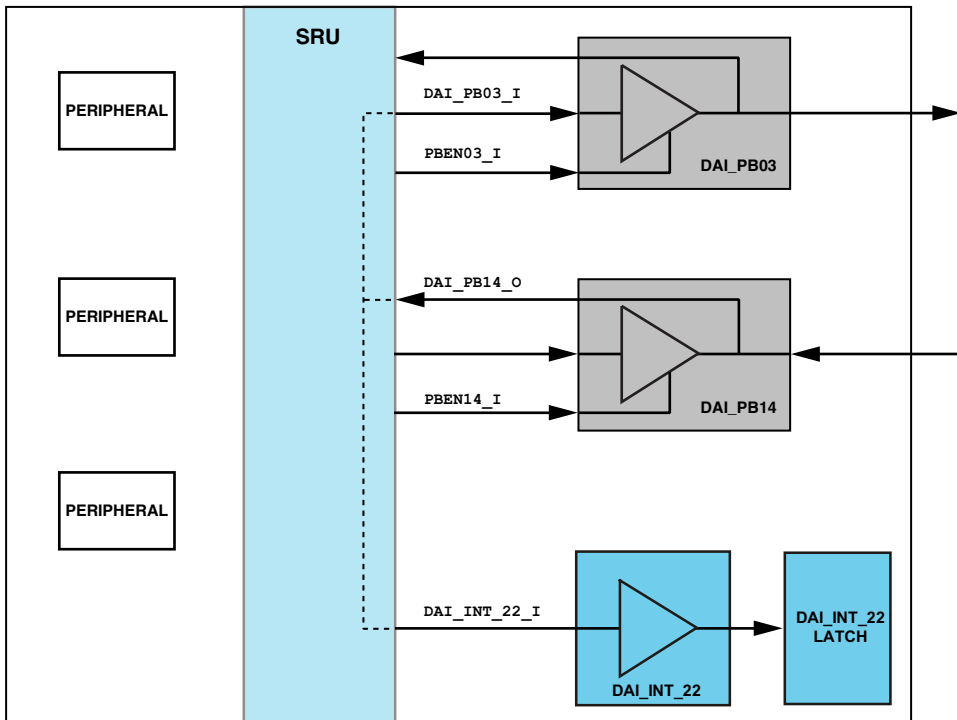

Figure 6-10. SRU Connection Between DAI Pin Buffers

Functional Description

Listing 6-2. SRU Connection Between DAI Pin Buffers and SPORTs

```
SRU(SPORT0_CLK_PBEN_0, PBEN03_I); // DAI pin 3 as output
nop;
SRU(SPORT0_CLK_0, DAI_PB03_I); // connect to DAI pin 3
nop;
SRU(SPORT0_CLK_0, SPORT1_CLK_I); // connect to SPORT1
nop;
SRU(SPORT0_CLK_0, SPORT2_CLK_I); // connect to SPORT2
```

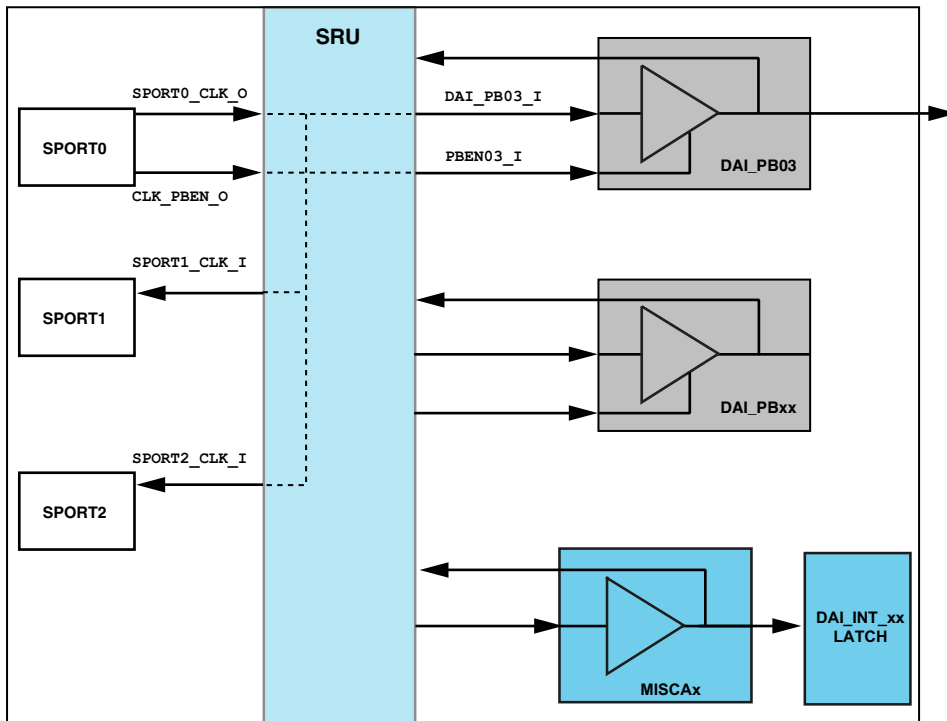

Figure 6-11. SRU Connection Between DAI Pin Buffers and SPORTs

Listing 6-3. SRU Connection SPORT/PCG to MISC/DAI Pin Buffers

```

SRU(HIGH, PBEN03_I);           // DAI pin 3 output
nop;
SRU(DAI_PB14_0, DAI_PB03_I); // connect pin 3 and 14
nop;
SRU(PCG_CLKB_0, DAI_PB14_I); // connect PCG and pin 14
nop;
SRU(SPORT2_FS_0, MISCA4_I);  // connect SPORT to MISCA
nop;
SRU(MISCA4_0, PBEN14_I);     // connect MISCA to PBEN14
nop;
SRU(HIGH, INV_MISCA4_I);     // invert MISCA4 input
    
```

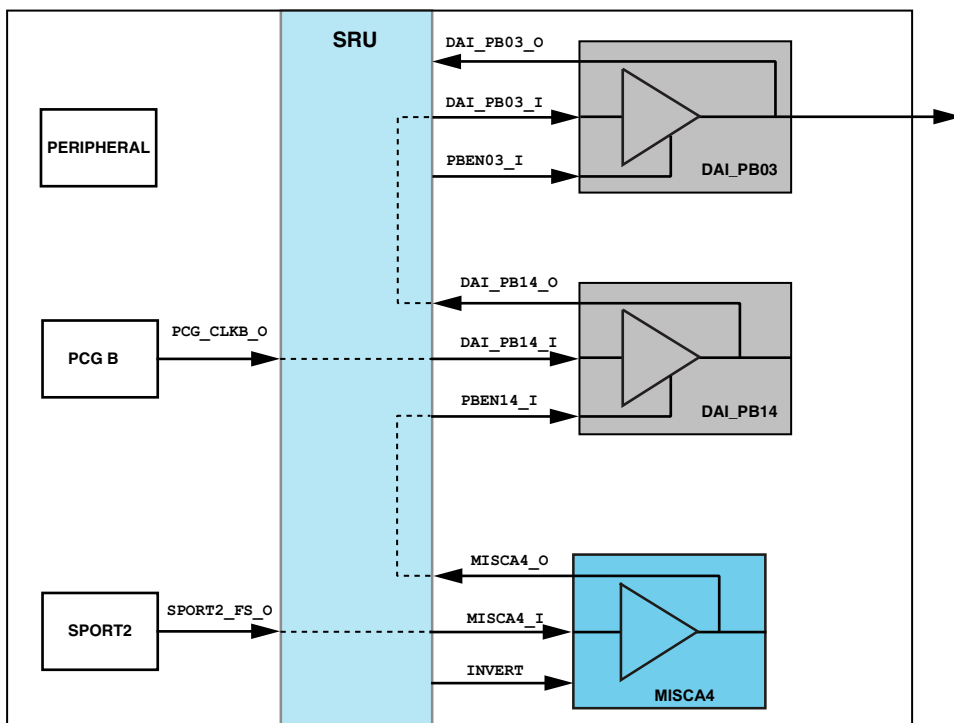

Figure 6-12. SRU Connection SPORT/PCG to MISC/DAI Pin Buffers

Functional Description

DAI Routing Capabilities

Table 6-1 provides an overview about the different routing capabilities for the DAI unit. The DAI groups allow routing of specific signals like clocks, data, frame syncs.

Table 6-4. DAI Routing Capabilities

DAI Group	Input (xxxx_I)	Output (xxxx_O)	
A-Clocks	SPORT7-0 SRC3-0 IDP7-0 PCG A, B, C, D (Ext. clock, Ext. Sync) S/PDIF-Tx (clock, HF Clock, ext. sync) SPDIF-Rx (ext. clock)	SPORT5-0 PCG A, B S/PDIF Rx (clock, TDM clock)	DAI Pin Buffer20-1 Logic level high Logic level low
B-Data	SPORT7-0 A, B SRC3-0 (data, TDM data) IDP7-0 S/PDIF Tx/Rx	SPORT7-0 A, B SRC3-0 (data, TDM data) S/PDIF Tx/Rx	
C-Frame Sync	SPORT7-0 SRC3-0 IDP7-0	SPORT5-0 PCG A, B S/PDIF Rx	
D-Pin Buffer Inputs	DAI Pin Buffer 20-1 DAI Pin Buffer 19 Inversion DAI Pin Buffer 20 Inversion	SPORT7-0A/B (data) SPORT7-0 (clock, FS, TDV, data) S/PDIF Rx (clock, TDM clock, FS, data, ext. PLL) S/PDIF Tx (data, block start) PDAP (output strobe) PCG C, D (clock, FS) SRC3-0 (data)	
E-Miscellaneous Signals	DAI Interrupt 31-22 MISCA5-0 MISCA4 Input Inversion MISCA5 Input Inversion	SPORT5-0 (FS) PCG A (clock) PCG B (clock, FS) S/PDIF Tx (block start)	
F-Pin Buffer	DAI Pin Buffer Enable 20-1	SPORT7-0 (clock, FS, data, TDV) MISCA5-0	Logic level high Logic level low

DPI Routing Capabilities

Table 6-2 provides an overview about the different routing capabilities for the DPI unit.

Table 6-5. DPI Routing Capabilities

DAI Group	Input (xxxx_I)	Output (xxxx_O)	
A-Miscellaneous Signals	SPI (MOSI, MISO, DS, CLK) SPIB (MOSI, MISO, DS, CLK) TWI (clock, data) UART1-0 RX data Timer2-0 FLAG15-4 MISCB8-0 DPI Interrupt 13-5	Timer UART1-0 TX Data	DPI Pin Buffer Logic level high Logic level low
B-Pin Buffer Input	DPI14-1 Pin Buffer Input	Timer2-0 UART1-0 TX data SPI (MOSI, MISO, DS, CLK, SPIFLG) SPIB (MOSI, MISO, DS, CLK, SPIBFLG) FLAG15-4 PCG(C-D) (clock, FS)	
C-Pin Buffer Enable	DPI14-1 Pin Buffer Enable	Timer2-0 SPI (MOSI, MISO, DS, CLK) SPIB (MOSI, MISO, DS, CLK) UART1-0 TX FLAG15-4 TWI (clock, data) MISCB8-0	

Functional Description

Pin Buffer Input

DAI group D or DPI group B are used to specify any signals that are driven off-chip by the pin buffers. A pin buffer input (PB_{xx_I}) is driven as an output from the processor when the pin buffer enable is set (= 1).

Each physical pin (connected to a bonded pad) may be routed via the SRU to any of the outputs of the DAI/DPI peripherals, based on the bit field values. The SRU also may be used to route signals that control the pins in other ways. Many signals may be configured for use as control signals.

Any of the DAI/DPI pins may also be considered general-purpose input/output (GPIO) pins. Each of the DAI pins can also be set to drive a high or low logic level to assert signals. They can also be used as DAI/DPI interrupt sources.

On the DAI, two dedicated input pin buffers are allowed to invert the input level on the pins by a bit setting. However this only applies if the buffer is not assigned to itself.

Pin Buffer Enable

DAI group F or DPI group C signals are used to specify whether each DAI/DPI pin is used as an output or an input by setting the source for the pin buffer enables. When a pin buffer enable ($PBEN_{xx_I}$) is set (= 1), the signal present at the corresponding pin buffer input (PB_{xx_I}) is driven off-chip as an output. When a pin buffer enable is cleared (= 0), the signal present at the corresponding pin buffer input is ignored.

The pin enable control registers activate the drive buffer for each of the DAI/DPI pins. When the pins are not enabled (driven), they can be used as inputs.

Though peripherals are capable of operating bidirectionally, it is not required that all peripheral's $_I$ and $_O$ signals should be connected to the pin buffer. If the system design only uses a signal in one direction, it is

simpler to connect the pin buffer enable pin directly to high or low as appropriate.

Furthermore, signals in the SRU other than the pin buffer enable signal (which is generated by the peripheral) may be routed to the pin buffer enable input. For example, an outside source may be used to ‘gate’ a pin buffer output by controlling the corresponding pin buffer enable.

Miscellaneous Signals

DAI group E or DPI group C connections are slightly different from the others in that the inputs and outputs being routed vary considerably in function. This group routes control signals and provides a means of connecting signals between groups.

For the DAI, the `MISCAx_I` signals appear as inputs in group E, but do not directly feed any peripheral. Rather, the `MISCAx_0` signals reappear as outputs in group F.

For the DPI, the `MISCBx_I` signals appear as inputs in group A, but do not directly feed any peripheral. Rather, the `MISCBx_0` signals reappear as outputs in group C.

Additional connections among groups provide a surprising amount of utility. Since the output groups C and F dictate pin direction, these few signal paths enable a number of possible uses and connections for the DAI/DPI pins. A few examples include:

- One pin’s input can be patched to another pin’s output, allowing board-level routing under software control.
- A pin input can be patched to another pin’s enable, allowing an off-chip signal to gate an output from the processor.
- Any of the DAI pins can be used as interrupt sources or general-purpose I/O (GPIO) signals.

Functional Description

On the DAI, two dedicated miscellaneous inputs are allowed to invert the input level on the buffer by a bit setting.

The SRU enables many possible functional changes, both within the processor as well as externally. Used creatively, it allows system designers to radically change functionality at runtime, and to potentially reuse circuit boards across many products.

DAI Default Routing

When the processor comes out of reset, the SPORT junctions are bidirectional to the DAI pin buffers (Figure 6-13, Figure 6-14). This allows systems to use the SPORTs as either master or slave (without changing the routing scheme). Therefore, programs only need to use the SPORT control register settings to configure master or slave operation. Note that all DAI inputs which are not routed by default are tied to signal low.



The DPI default routing for the ADSP-2136x and ADSP-2137x processors is not available on previous SHARC families.

Digital Application/Digital Peripheral Interfaces

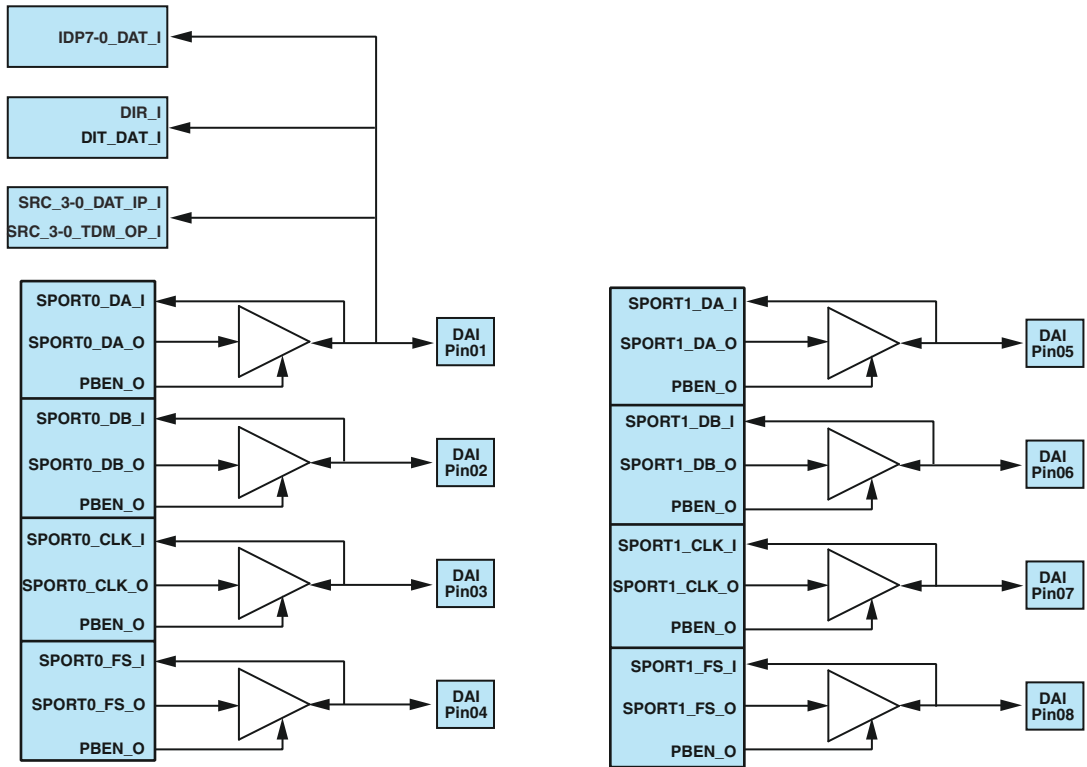

Figure 6-13. DAI Default Routing

Functional Description

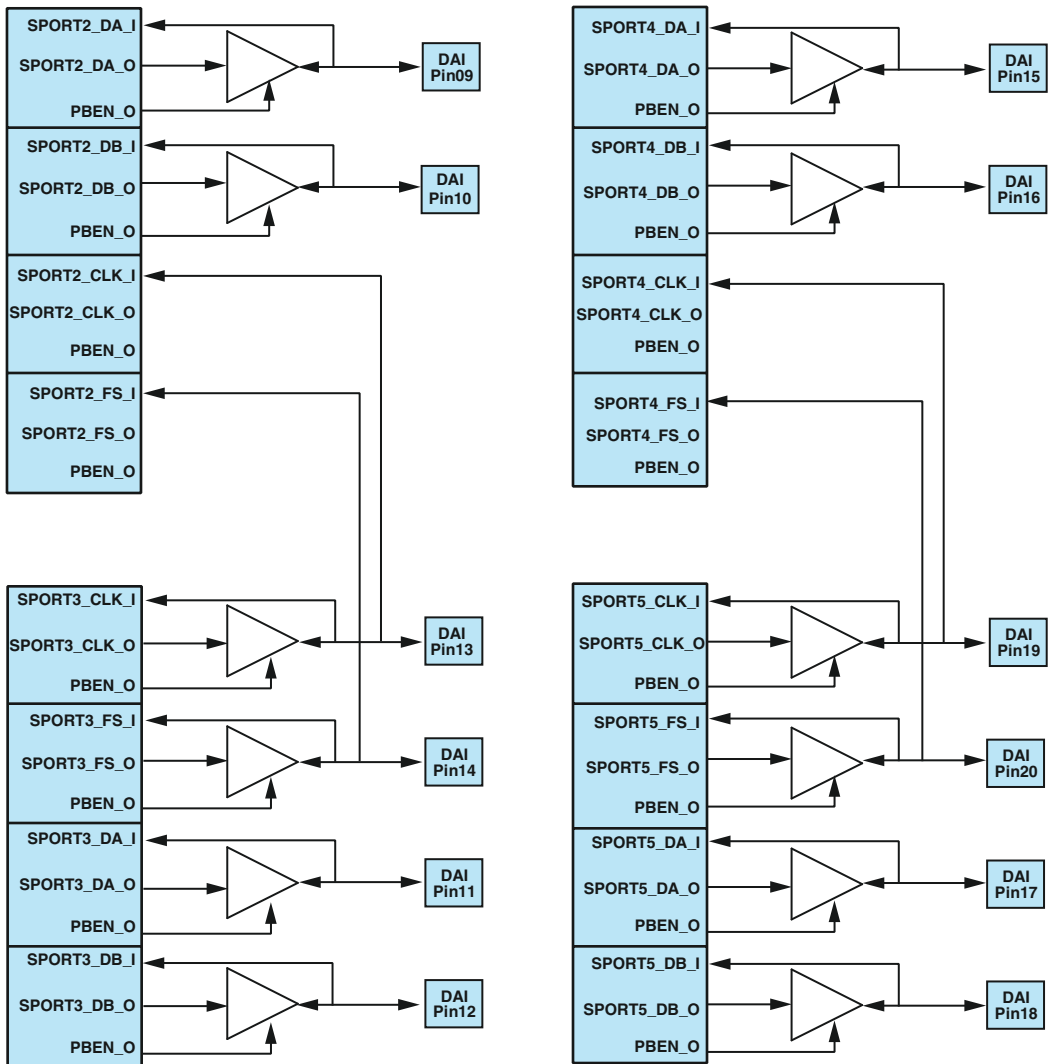

Figure 6-14. DAI Default Routing (Cont'd)

DPI Default Routing

When the processor comes out of reset, some default routing is established (Figure 6-15). This scheme allows systems to use the SPI as either master or slave (without changing the routing scheme). Programs only need to use the SPI control register settings to configure master or slave operation.

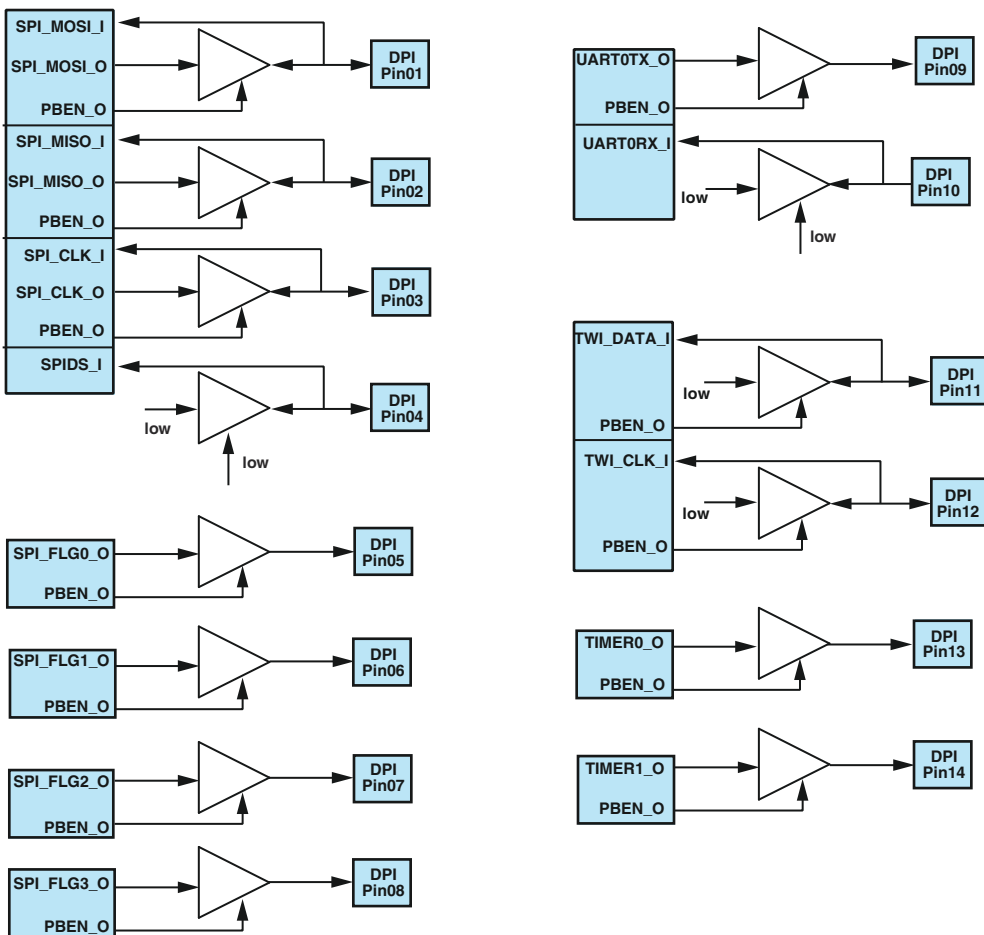

Figure 6-15. DPI Default Routing

Interrupts



All DPI inputs which are not routed by default are tied to signal low. The default routing is used for SPI master/slave booting.

Interrupts

The DAI/DPI contain a dedicated interrupt controller that signals the core when DAI or DPI peripheral events occur.

System versus Exception Interrupts

Generally, interrupts are classified as system or exception. Exception events include any hardware interrupts (for example, resets) and emulation interrupts, math exceptions, and illegal accesses to memory that does not exist.

Programs can manage responses to signals by configuring registers. In a sample audio application, for example, upon detection of a change of protocol, the output can be muted. This change of output and the resulting behavior (causing the sound to be muted) results in an alert signal (an interrupt) being introduced in response (if the detection of a protocol change is a high priority interrupt).

Exception events are treated as high priority events. In comparison, system interrupts are “deterministic”—specific events emanating from a source (the causes), the result of which is the generation of an interrupt. The expiration of a timer can generate an interrupt, a signal that a serial port has received data that must be processed, a signal that an SPI has either transmitted or received data, and other software interrupts like the insertion of a trap that causes a breakpoint—all are conditions, which identify to the core that an event has occurred.

Since DAI specific events generally occur infrequently, the DAI IC classifies such interrupts as either high or low priority interrupts. Within these

broad categories, programs can indicate which interrupts are high and which are classified as low.

Functional Description

There are several registers in the DAI interrupt controller that can be configured to control how the DAI interrupts are reported to and serviced by the core's interrupt controller.

The DAI contains its own interrupt controller that indicates to the core when DAI audio peripheral related events have occurred. Since audio events generally occur infrequently relative to the SHARC processor core, the DAI interrupt controller reduces all of its interrupts onto two interrupt signals within the core's primary interrupt systems.

Among other options, each DAI interrupt can be mapped either as a high or low priority interrupt in the primary interrupt controller. Certain DAI interrupts can be triggered on either the rising or the falling edge of the signals, and each DAI interrupt can also be independently masked.

DAI Interrupt Channels

The DAI can handle up to 32 interrupts as shown below.

- 8 x IDP DMA channels (Input data port)
- 2 x IDP FIFO status (Input data port)
- 10 x miscellaneous interrupts
- 8 x S/PDIF receiver status
- 4 x SRC (sample rate converter)

DAI Interrupt Priorities

As described above, the DAI interrupt controller registers provide 32 independently-configurable interrupts.

Just as the core has its own interrupt latch registers (IRPTL and LIRPTL), the DAI has its own latch registers (DAI_IMASK_L and DAI_IMASK_H). When a DAI interrupt is configured to be high priority, it is latched in the DAI_IMASK_H register. When any bit in the DAI_IMASK_H register is set (= 1), bit 11 in the IRPTL register is also set and the core services that interrupt with high priority. When a DAI interrupt is configured to be low priority, it is latched in the DAI_IMASK_L register. Similarly, when any bit in the DAI_IMASK_L register is set (= 1), bit 6 in the LIRPTL register is also set and the core services that interrupt with low priority.

 By default interrupts are mapped onto low priority interrupt.

DPI Interrupt Channels

The DPI can handle up to 12 interrupts as shown below.

- 1 x TWI FIFO status
- 4 x UART channels
- 9 x miscellaneous interrupts

DPI Interrupt Priorities

Just as the core has its own interrupt latch registers (IRPTL and LIRPTL), the DPI has its own latch registers (DPI_IMASK). When a DPI interrupt is configured, it is latched in the DPI_IMASK register. When any bit in the DPI_IMASK register is set (= 1), bit 11 (DPII) in the IRPTL register is also set and the core services that interrupt.

 The DPI interrupt controller has no priority option.

DAI Miscellaneous Interrupts

As described above, the DAI interrupt controller registers provide 10 independently-configurable interrupts labeled as `DAI_31-22_INT`. Any trigger on the routed DAI inputs `DAI_INT_31-22_I` can cause an interrupt latch event in `DAI_IMASK` register if unmasked.

 There are two signal naming conventions: the DAI interrupt controller bits are named `DAI_31-22_INT` and its corresponding SRU signals are named `DAI_INT_31-22_I`.

Signals from the SRU can be used to generate interrupts. For example, when `DAI_30_INT` (bit 30) of `DAI_IMASK_H` is set to one, any signals from the external miscellaneous channel A2 generate an interrupt. If set to one, DAI interrupts trigger an interrupt in the core and the interrupt latch is set. A read of this bit does not reset it to zero. The bit is only set to zero when the cause of the interrupt is cleared. A DAI interrupt indicates the source (in this case, external miscellaneous A, channel 2), and checks the IVT for an instruction (next operation) to perform.

[Table 6-7](#) provides an overview of DAI miscellaneous interrupts.

Table 6-6. DAI Miscellaneous Interrupt Overview

Interrupt Source	Interrupt Condition	Interrupt Completion	Interrupt Acknowledge	Default IVT
DAI MISCA (10 channels)	<ul style="list-style-type: none"> – Rising edge – Falling edge – Rising/falling edge 		Read-to-clear <code>DAI_IMASK_x</code> + RTI instruction	P0I, P12I

DPI Miscellaneous Interrupts

As described above, the DPI interrupt controller registers provide 9 independently-configurable interrupts labeled as `DPI_13-5_INT`. Any trigger on the routed DPI inputs `MISCB8-0_I` can cause an interrupt latch event in `DPI_13-5_INT` if enabled.

Interrupts

 There are two signal naming conventions: the DPI interrupt controller bits are named `DPI_13-5_INT` and its corresponding SRU signals are named `MISCB8-0_I`.

Signals from the SRU2 group C can be used to generate interrupts. For example, when `DPI_13_INT` (bit 13) of `DPI_IMASK` is set to one, any signals from the miscellaneous channel 8 `MISCB8_I` generates an interrupt. If set to one, the DPI triggers an interrupt in the core and the interrupt latch is set. A read of this bit does not reset it to zero. The bit is only set to zero when the cause of the interrupt is cleared. A DPI interrupt indicates the source (in this case, miscellaneous, Channel 8), and checks the IVT for an instruction (next operation) to perform.

Table 6-7 provides an overview of DPI miscellaneous interrupts.

Table 6-7. DPI Miscellaneous Interrupt Overview

Interrupt Source	Interrupt Condition	Interrupt Completion	Interrupt Acknowledge	Default IVT
DPI MISCB (9 channels)	– Rising edge – Falling edge – Rising/falling edge		Read-to-clear <code>DPI_IMASK_x</code> + RTI instruction	P14I

DAI/DPI Interrupt Mask Events

For interrupt sources that correspond to waveforms (as opposed to DAI event signals such as DMA complete or buffer full), the edge of a waveform may be used as an interrupt source as well. Just as interrupts can be generated by a source, interrupts can also be generated and latched on the rising (or falling) edges of a signal.

 Only the DAI interrupt controller latches interrupts on both edges. This ability does not exist in the core interrupt controller.

When a signal comes in, the system needs to determine what kind of signal it is and what kind of protocol, as a result, to service. The preamble

indicates the signal type. When the protocol changes, output (signal) type is noted.

For audio applications, the processors need information about interrupt sources that correspond to waveforms (not event signals). As a result, the falling edge of the waveform may be used as an interrupt source as well. Programs may select any of these three conditions:

- Latch on the rising edge
- Latch on the falling edge
- Latch on *both* the rising and falling edge

Table 6-8 shows which interrupts are valid on rising and or falling edges

Table 6-8. DAI/DPI Interrupt Valid Edges

Interrupt Source	DAI_IMASK_RE	DAI_IMASK_FE
S/PDIF Rx	Yes	Yes
IDP_FIFO	Yes	No
IDP_DMA	Yes	No
SRC Mute Out	Yes	Yes
Miscellaneous (31–22)	Yes	Yes
	DPI_IMASK_RE	DPI_IMASK_FE
UART Channel Bits 3–0	Yes	No
TWI Bits (4)	Yes	No
Miscellaneous Interrupt Bits (5–13)	Yes	Yes

Use of the DAI_IMASK_RE or DAI_IMASK_FE registers allows programs to notice and respond to rising edges, falling edges, both rising and falling edges, or neither rising nor falling edges so they can be masked separately.

Interrupts

Enabling responses to changes in conditions of signals (including changes in DMA state, introduction of error conditions, and so on) can only be done using the `DAI_IMASK_RE` register.

DAI Interrupt Acknowledge

Any asynchronous or synchronous interrupt causes a latency, since it forces the core to stop processing an instruction in process, then vector to the interrupt service routine (ISR), (which is basically an interrupt vector table (IVT) lookup), then proceed to implement the instruction referenced in the IVT. For more information, see [Appendix B, Peripheral Interrupt Control](#).

When an interrupt from the DAI must be serviced, one of the two core ISRs must query the DAI's interrupt controller to determine the source(s). Sources can be any one or more of the interrupt controller's 32 configurable channels (`DAI_31-0_INT`). [For more information, see “Interrupt Controller Registers” on page A-69.](#)

 The DAI triggers two interrupts in the primary IVT—one each for low or high priority. When any interrupt from the DAI needs to be serviced, one of the two core ISRs must interrogate the DAI's interrupt controller to determine the source(s).

When a DAI interrupt occurs, the high or low priority core ISR queries its corresponding register to determine which of the 32 interrupt sources requires service. Sources can be any one or more of the interrupt controller's 32 configurable channels. When `DAI_IMASK_H` is read, the high priority latched interrupts are cleared. When `DAI_IMASK_L` is read, the low priority latched interrupts are cleared.

 Reading the DAI's interrupt latches clears the interrupts (Read-to-Clear bit type). Therefore, the ISR must service *all* the interrupt sources it discovers. That is, if multiple interrupts are

latched in one of the `DAI_IMASK_x` registers, all of them must be serviced before executing an RTI instruction. For more information, see “Interrupt Controller Registers” on page A-69.

DPI Interrupt Acknowledge

Any asynchronous or synchronous interrupt causes a latency, since it forces the core to stop processing an instruction in process, then vector to the interrupt service routine (ISR), (which is basically an interrupt vector table (IVT) lookup), then proceed to implement the instruction referenced in the IVT. For more information, see “Interrupt Controller Registers” on page A-69.



The DPI triggers one interrupt in the primary IVT.

When a DPI interrupt occurs, the `DPI_IMASK` register determines which of the 12 interrupt sources requires service.



Reading the DPI's interrupt latches (`DPI_IMASK`) clears the interrupts (Read-to-Clear bit type). Therefore, the ISR must service *all* the interrupt sources it discovers. That is, if multiple interrupts are latched in one of the registers, all of them must be serviced before executing an RTI instruction.

For UART and TWI interrupts in core operation, the interrupt acknowledge mechanisms may be different. For more information, refer to the specific chapters ([Chapter 14, UART Port Controller](#), [Chapter 15, Two-Wire Interface Controller](#)).

Core Versus DAI/DPI Interrupts

A pair of registers (`DAI_IMASK_H` and `DAI_IMASK_L`) replace functions normally performed by the `IRPTL` register. A single register (`DAI_IMASK_PRI`) specifies to which latch these interrupts are mapped.

Debug Features

Two registers (`DAI_IMASK_RE` and `DAI_IMASK_FE`) replace the DAI peripheral's version of the `IMASK` register. As with the `IMASK` register, these DAI registers provide a way to specify which interrupts to notice and handle, and which interrupts to ignore. These dual registers function like `IMASK` does, but with a higher degree of granularity.

 The DAI/DPI interrupt controller has the same interrupt latency as the core interrupt controller. This latency is 6 cycles to respond to asynchronous interrupts.

Note that `IRPTL` and `LIRPTL` are system registers. All DAI interrupt registers (`DAI_IMASK_x`) are memory mapped registers.

Debug Features

The following sections describe features that can be used to help in debugging the DAI.

DAI Shadow Registers

The `DAI_IMASK_L_SH` and `DAI_IMASK_H_SH` shadow registers are provided for the `DAI_IMASK_L` and `DAI_IMASK_H` registers respectively. Reads of these registers returns data in `DAI_IMASK_L` and `DAI_IMASK_H` respectively without clearing the contents of these registers.

DPI Shadow Registers

The `DPI_IMASK_SH` shadow register is provided for register `DPI_IMASK`. A read of this register (RO) returns data in `DPI_IMASK` without clearing the contents of this register.

Loop Back Routing

The serial peripherals (SPORT and SPI) support an internal loop back mode. If the loop back bit for each peripheral is enabled, it connects the transmitter with the receiver block internally (does not signal off-chip). The SRU can be used for this propose. [Table 6-9](#) describes the different possible routing based on the peripheral.

 The peripheral's loop back mode for debug is independent from both of the signal routing units.

Table 6-9. Loop Back Routing

Peripheral	Loopback Mode	SRU/SRU2 Internal Routing for Loopback	SRU/SRU2 External Routing for Loopback
DAI			
IDP	N/A	N/A	N/A
SPORT	Yes	SPORT _{x_xx} _O → SPORT _{x_xx} _I	SPORT _{x_xx} _O → DAI_PB _{xx} _I DAI_PB _{xx} _O → SPORT _{x_xx} _I
S/PDIF Tx/Rx	No	DIT_O → DIR_I	DIT_O → DAI_PB _{xx} _I DAI_PB _{xx} _O → DIR_I
SRC	No	SRC _x _DAT_OP_O → SRC _x _DAT_IP_I	SRC _x _DAT_OP_O → DAI_PB _{xx} _I DAI_PB _{xx} _O → SRC _x _DAT_IP_I
DPI			
Timer	No	TIMER _x _O → TIMER _x _I	TIMER _x _O → DPI_PB _{xx} _I DPI_PB _{xx} _O → TIMER _x _I
SPI	Yes	No	SPI _{x_xx} _O → DPI_PB _{xx} _I DPI_PB _{xx} _O → SPI _{x_xx} _I
UART0	No	UART0_TX_O → UART0_RX_I	UART0_TX_O → DPI_PB _{xx} _I DPI_PB _{xx} _O → UART0_RX_I
TWI	No	No	TWI _{xx} _O → DPI_PB _{xx} _I DPI_PB _{xx} _O → TWI _{xx} _I

Effect Latency

The total effect latency is a combination of the write effect latency (core access) plus the peripheral effect latency (peripheral specific).

Write Effect Latency

For details on write effect latency, see *SHARC Processor Programming Reference*.

Signal Routing Unit Effect Latency

After the DAI/DPI registers are configured the effect latency is 2 PCLK cycles minimum and 3 PCLK cycles maximum.

Programming Model

As discussed in the previous sections, the signal routing unit is controlled by writing values that correspond to signal sources into bit fields that further correspond to signal inputs. The SRU is arranged into functional groups such that the registers that are made up of these bit fields accept a common set of source signal values.

In order to ease the coding process, the header file `SRU.H` is included with the CrossCore or VisualDSP++ tools. This file implements a macro that abstracts away most of the work of signal assignments and functions. The macro has identical syntax in C/C++ and assembly, and makes a single connection from an output to an input as shown below.

```
SRU(Output Signal, Input Signal);
```

The names passed to the macro are the names given “[DAI Signal Routing Unit Registers](#)” on page A-40. To use this macro, add the following line to your source code:

The following lines illustrate how the macro is used:

Listing 6-4. DAI Macro Code

```
#include <sru.h>;
/* The following lines illustrate how the macro is used: */
/* Route SPORT 1 clock output to pin buffer 5 input */
    SRU(SPORT1_CLK_0,DAI_PB05_I);

/* Route pin buffer 14 out to IDP3 frame sync input */
    SRU(DAI_PB14_0,IDP3_FS_I);

/* Connect pin buffer enable 19 to logic low */
    SRU(LOW,PBEN19_I);
```

Additional example code is available on the Analog Devices Web site.



There is a macro that has been created to connect peripherals used in a DAI configuration. This code can be used in both assembly and C code. See the INCLUDE file SRU.H.

There is also a software plug-in called the Expert DAI that greatly simplifies the task of connecting the signals described in this chapter. This plug-in is described in Engineer-to-Engineer Note EE-243, “Using the Expert DAI for ADSP-2126x and ADSP-2136x SHARC Processors”. This EE note is also found on the Analog Devices Web site.

DAI Example System

A complete system using the DAI peripherals (SPORTs, PCG, S/PDIF) is shown in [Figure 6-16](#).

Programming Model

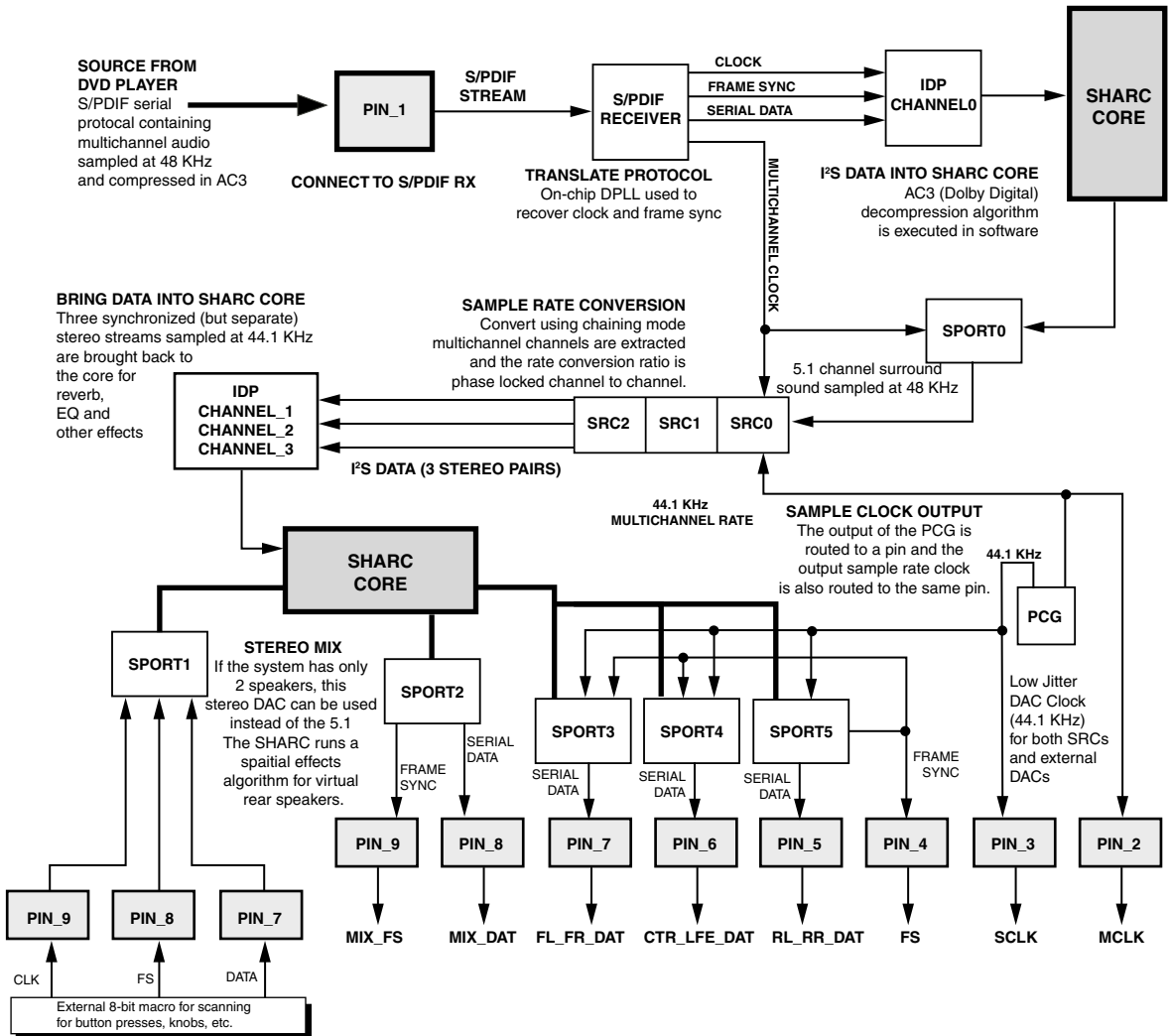

Figure 6-16. DAI Example

7 SERIAL PORTS

The processors have eight independent, synchronous serial ports (SPORTs) that provide an I/O interface to a wide variety of peripheral devices. They are called SPORT0, SPORT1, SPORT2, SPORT3, SPORT4, SPORT5, SPORT6, and SPORT7. Each SPORT has its own set of control registers and data buffers. With a range of clock and frame synchronization options, the SPORTs allow a variety of serial communication protocols and provide a glueless hardware interface to many industry-standard data converters and CODECs. The interface specifications are shown in [Table 7-1](#).

Table 7-1. Serial Port Specifications

Feature	SPORT7-0[AB]
Connectivity	
Multiplexed Pinout	No
SRU DAI Required	Yes
SRU DAI Default Routing	Yes
SRU2 DPI Required	No
SRU2 DPI Default Routing	N/A
Interrupt Control	Yes
Protocol	
Master Capable	Yes
Slave Capable	Yes
Transmission Simplex	Yes
Transmission Half Duplex	Yes

Features

Table 7-1. Serial Port Specifications (Cont'd)

Feature	SPORT7-0[AB]
Transmission Full Duplex	No
Access Type	
Data Buffer	Yes
Core Data Access	Yes
DMA Data Access	Yes
DMA Channels	2 per SPORT
DMA Chaining	Yes
Boot Capable	No
Local Memory	No
Clock Operation	PCLK/4 (PCLK/8, if SPORT is slave transmitter or master receiver)

Features

Serial ports offer the following features and capabilities:

- Five operation modes (“[Operating Modes](#)” on page 7-20):
 1. Standard serial
 2. Left-justified
 3. I²S
 4. Packed
 5. Multichannel
- Two bidirectional channels (A and B) per serial port, configurable as either transmitters or receivers. Each serial port can also be configured as two receivers or two transmitters, permitting two

unidirectional streams into or out of the same serial port. This bidirectional functionality provides greater flexibility for serial communications. Further, two SPORTs can be combined to enable full-duplex, dual-stream communications.

Serial ports can operate at a maximum of one-fourth the peripheral clock rate of the processor. If channels A and B are active, each SPORT has a maximum throughput of $2 \times \text{PCLK}/4$ rate.

- Chained DMA operations for multiple data blocks, see [“DMA Chaining” on page 2-27](#).
- DMA Chain insertion mode allows the SPORTs to change DMA priority during chaining, see [“Enter DMA Chain Insertion Mode” on page 7-57](#).
- Data words between 3 and 32 bits in length, either most significant bit (MSB) first or least significant bit (LSB) first. Words must be between 8 and 32 bits in length for I²S and left-justified mode.
- 128-channel multichannel is supported in multichannel mode operation, useful for H.100/H.110 and other telephony interfaces described in [“Multichannel Mode” on page 7-31](#).
- μ -law and A-law compression/decompression hardware companding on transmitted and received words when the SPORT operates in multichannel mode.



Receive comparison and 2-dimensional DMA are not supported.

Pin Descriptions

Table 7-2 describes pin function.

Table 7-2. SPORT Pin Descriptions

Internal Node	Direction	Description
SPORT7-0_DA_I/O	I/O	Data receive or transmit channel A. Bidirectional data pin. This signal can be configured as an output to transmit serial data, or as an input to receive serial data.
SPORT7-0_DB_I/O	I/O	Data receive or transmit channel B. Bidirectional data pin. This signal can be configured as an output to transmit serial data, or as an input to receive serial data.
SPORT7-0_CLK_I/O	I/O	Transmit/Receive Serial Clock. This signal can be either internally or externally generated.
SPORT7-0_FS_I/O	I/O	Transmit/Receive Frame Sync. The frame sync pulse initiates shifting of serial data. This signal is either generated internally or externally. It can be active high or low or an early or a late frame sync, in reference to the shifting of serial data.
SPORT7-0_TDV_O	O	Multichannel Transmit Data Valid. This signal is only active in SPORT multichannel mode configured as transmitter. The signal is asserted during enabled slots based on the transmit channel (companding) Selection registers (MTxCSy/MTxCCSy).
SPORT7-0_DA_PBEN_O	O	Only driven in master mode.
SPORT7-0_DB_PBEN_O	O	
SPORT7-0_CLK_PBEN_O	O	
SPORT7-0_FS_PBEN_O	O	
SPORT7-0_TDV_PBEN_O	O	

SRU Programming

Any of the serial port's signals can be mapped to digital applications interface (DAI_Px) pins through the signal routing unit (SRU) as shown in [Table 7-3](#). For more information, see [Chapter 6, Digital Application/Digital Peripheral Interfaces](#).

 SPORTs 6 and 7 receive their clocks from other routed sources but cannot route their own clocks to other SPORTs or other peripherals internally through the SRU. If SPORTs 6 and 7 are needed externally, they have to be routed through the DAI pins.

Table 7-3. SPORT DAI/SRU Signal Connections

Internal Node	DAI Connection	SRU Register
Inputs		
SPORT7-0_CLK_I	Group A	SRU_CLK1-0
SPORT7-0_FS_I	Group C	SRU_FS0
SPORT7-0_DA_I	Group B	SRU_DAT2-0
SPORT7-0_DB_I		
Outputs		
SPORT5-0_CLK_O	Group A, D	
SPORT7-6_CLK_O	Group D	
SPORT5-0_FS_O	Group C, D, E	
SPORT7-6_FS_O	Group D	
SPORT7-0_DA_O	Group B, D	
SPORT7-0_DB_O		
SPORT7-0_TDV_O		

Table 7-3. SPORT DAI/SRU Signal Connections (Cont'd)

Internal Node	DAI Connection	SRU Register
SPORT7-0_CLK_PBEN_O	Group F	
SPORT7-0_FS_PBEN_O		
SPORT7-0_DA_PBEN_O		
SPORT7-0_DB_PBEN_O		
SPORT7-0_TDV_PBEN_O		

SRU SPORT Receive Master

If the SPORT is operating as receive master, it must feed its master output clock back to its input clock. This is required to trigger the SPORT's state machine. Using SPORT 4 as an example receive master, programs should route SPORT4_CLK_0 to SPORT4_CLK_I. This is not required if the SPORT is operating as a transmitter in master mode.

SRU SPORT Signal Integrity

There is some sensitivity to noise on the clock (SPORT_x_CLK) and frame sync (SPORT_x_FS) signals when the SPORT is configured as a master receiver. By correctly programming the signal routing unit (SRU) clock and frame sync registers, the reflection sensitivity in these signals can be avoided.

[Figure 6-10 on page 6-21](#) shows the default routing of the serial port where the SRU maps to:

- the signal from the DAI pin (DAI_PB_{xx}_0) back to the SPORT clock input (SPORT_x_CLK_I)
- the SPORT clock output (SPORT_x_CLK_0) to the pin buffer input (DAI_PB_{xx}_I)

By redirecting the signals as shown in [Figure 7-1](#) where the clock and frame sync outputs are routed directly back to their respective inputs, the signal sensitivity issue can be avoided.

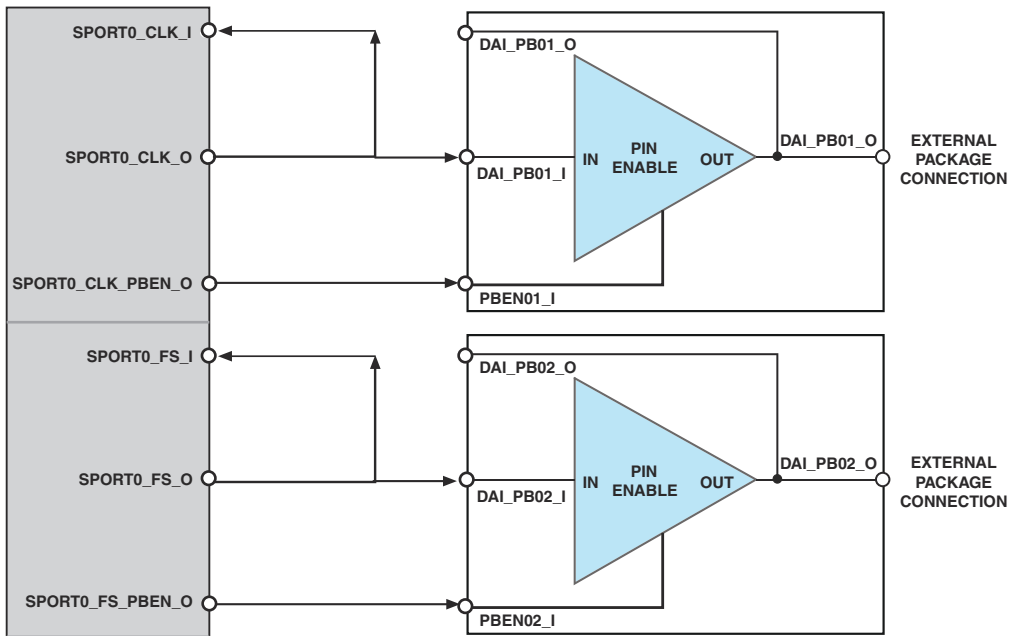

Figure 7-1. SRU Configuration when SPORT is Master Receiver.

Register Overview

This section provides brief descriptions of the major registers. For complete information, see [“Serial Port Registers”](#) on page A-70.

Serial Port Control Registers (SPCTLx). The SPCTLx registers control serial port modes and are part of the SPCTLx (transmit and receive) control registers. Other bits in these registers set up DMA and I/O processor related serial port features. For information about configuring a specific

Clocking

operation mode, refer to [Table 7-7 on page 7-23](#) and “[Operating Modes](#)” on [page 7-20](#).

Serial Port Error Registers (SPERRxx). Two error registers (SPERRCTLx/SPERRSTAT) are used to observe and control error handling during transfers. Detected errors can be frame sync violation or buffer over/underflow conditions. For more information, see “[Error Detection](#)” on [page 7-51](#) and “[Error Status](#)” on [page 7-53](#).

Multichannel Control Registers (SPMCTLx). There is one global control and status register for each SPORT (SPORT7–0) for multichannel operation. These registers define the number of channels, provide the status of the current channel, enable multichannel operation, and set the multichannel frame delay. These registers are described in “[Serial Port Registers](#)” on [page A-70](#).

Master Clock Divider Registers (DIVx). The DIVx registers contain divisor values that determine frequencies for internally-generated clocks and frame syncs. If your system requires more precision and less noise and jitter, refer to [Chapter 11, Precision Clock Generator](#).

Clocking

The fundamental timing clock of the SPORT modules is peripheral clock/4 (PCLK/4). Each serial port has a clock signal (SPORTx_CLK) for transmitting and receiving data on the two associated data signals. The clock signals are configured by the ICLK and CKRE bits of the SPCTLx control registers. A single clock signal clocks both A and B data signals (either configured as inputs or outputs) to receive or transmit data at the same rate.

Master Clock

The `CLKDIV` bit field specifies how many times the processor's internal clock (`PCLK`) is divided to generate the transmit and receive clocks. The frame sync (`SPORTx_FS`) is considered a receive frame sync if the data signals are configured as receivers. Likewise, the frame sync `SPORTx_FS` is considered a transmit frame sync if the data signals are configured as transmitters. The divisor is a 15-bit value, (bit 0 in divisor register is reserved) allowing a wide range of serial clock rates. Use the following equation to calculate the serial clock frequency:

Transmit master: $SCLK = PCLK \div (4 (CLKDIV + 1))$

Receive master: $SCLK = PCLK \div (8 (CLKDIV + 1))$

The maximum serial clock frequency is equal to one-fourth (0.25) the processor's internal peripheral clock (`PCLK`) frequency, which occurs when `CLKDIV` is set to zero. Use the following equation to determine the value of `CLKDIV`, given the `PCLK` frequency and desired serial clock frequency:

$$CLKDIV = (PCLK \div (4 \times SCLK)) - 1$$

If the serial clock of `SPORT` (`SCLK`) is required as general-purpose clock in a system, only the `ICLK/MSTR` bit and the serial clock divider register `DIVx` must be programmed.

Master Frame Sync

The bit field `FSDIV` specifies how many transmit or receive clock cycles are counted before a frame sync pulse is generated. In this way, a frame sync can initiate periodic transfers. The counting of serial clock cycles applies to internally- or externally-generated serial clocks. The formula for the number of cycles between frame sync pulses is:

$$\text{Number of serial clocks between frame syncs} = FSDIV + 1$$

Clocking

Use the following equation to determine the value of $FSDIV$, given the serial clock frequency and desired frame sync frequency:

$$FSDIV = (SCLK \div FSCLK) - 1$$

The frame sync is continuously active when $FSDIV = 0$. The value of $FSDIV$ should not be less than the serial word length minus one (the value of the $SLEN$ field in the serial port control register), as this may cause an external device to abort the current operation or cause other unpredictable results. If the serial port is not being used, the $FSDIV$ divisor can be used as a counter for dividing an external clock or for generating a periodic pulse or periodic interrupt. The serial port must be enabled for this mode of operation to work properly.

 Programs should not use master clock/frame sync on SPORTs to drive ADCs/DACs in high fidelity audio systems. Use the precision clock generator (PCG) instead.

Slave Mode

Exercise caution when operating with externally-generated transmit clocks near the frequency of $PCLK/4$ of the processor's internal clock. There is a delay between when the clock arrives at the $SPORTx_CLK$ node and when data is output. This delay may limit the receiver's speed of operation. Refer to the appropriate product data sheet for exact timing specifications. Note for slave transmit mode the maximum SPORT frequency is limited to $PCLK/8$.

Externally-generated late transmit frame syncs also experience a delay from when they arrive to when data is output. This can also limit the maximum serial clock speed. Refer to the *appropriate product data sheet* for exact timing specifications.

Functional Description

The following sections provides general information on the function of the SPORTs.

- “Architecture” below.
- “Data Types and Companding” on page 7-12.
- “Frame Sync” on page 7-16.

Architecture

A serial port receives serial data on one of its bidirectional serial data signals configured as inputs, or transmits serial data on the bidirectional serial data signals configured as outputs. It can receive or transmit on both channels simultaneously and unidirectionally, where the pair of data signals can both be configured as either transmitters or receivers.

The `SPORTx_DA` and `SPORTx_DB` channel data signals on each SPORT cannot transmit and receive data simultaneously for full-duplex operation. Two SPORTs must be combined to achieve full-duplex operation. The `SPTRAN` bit in the `SPCTLx` register controls the direction for both the A and B channel signals.

 The data direction of channel A and channel B on a particular SPORT must be the same.

Serial communications are synchronized to a clock signal. Every data bit must be accompanied by a clock pulse. Each serial port can generate or receive its own clock signal (`SPORTx_CLK`). Internally-generated serial clock frequencies are configured in the `DIVx` registers. The A and B channel data signals shift data based on the rate of `SPORTx_CLK`.

In addition to the serial clock signal, data may be signaled by a frame synchronization signal. The framing signal can occur at the beginning of an

Functional Description

individual word or at the beginning of a block of words. The configuration of frame sync signals depends upon the type of serial device connected to the processor. Each serial port can generate or receive its own frame sync signal ($SPORTx_FS$) for transmitting or receiving data. Internally-generated frame sync frequencies are configured in the $DIVx$ registers. Both the A and B channel data signals shift data based on their corresponding $SPORTx_FS$ signal.

Figure 7-2 shows a block diagram of a serial port. Setting the $SPTRAN$ bit enables the data buffer path, which, once activated, responds by shifting data in response to a frame sync at the rate of $SPORTx_CLK$. An application program must use the correct serial port data buffers, according to the value of $SPTRAN$ bit. The $SPTRAN$ bit enables either the transmit data buffers for the transmission of A and B channel data, or it enables the receive data buffers for the reception of A and B channel data. Inactive data buffers are not used.

The processor's SPORTs are not UARTs and cannot communicate with an RS-232 device or any other asynchronous communications protocol. One way to implement RS-232 compatible communication with the processor is to use two of the $FLAG$ pins as asynchronous data receive and transmit signals.

Data Types and Companding

Linear transfers occur in the primary channel, if the channel is active and companding is not selected for that channel. Companded transfers occur if the channel is active and companding is selected for that channel. The multichannel compand select registers, $MTxCCSy$ and $MRxCCSy$, specify the transmit and receive channels that are companded when multichannel mode is enabled.

Transmit or receive sign extension is selected by bit 0 of $DTYPE$ in the $SPCTLx$ register and is common to all transmit or receive channels. If bit 0 of $DTYPE$ is set, sign extension occurs on selected channels that do not have

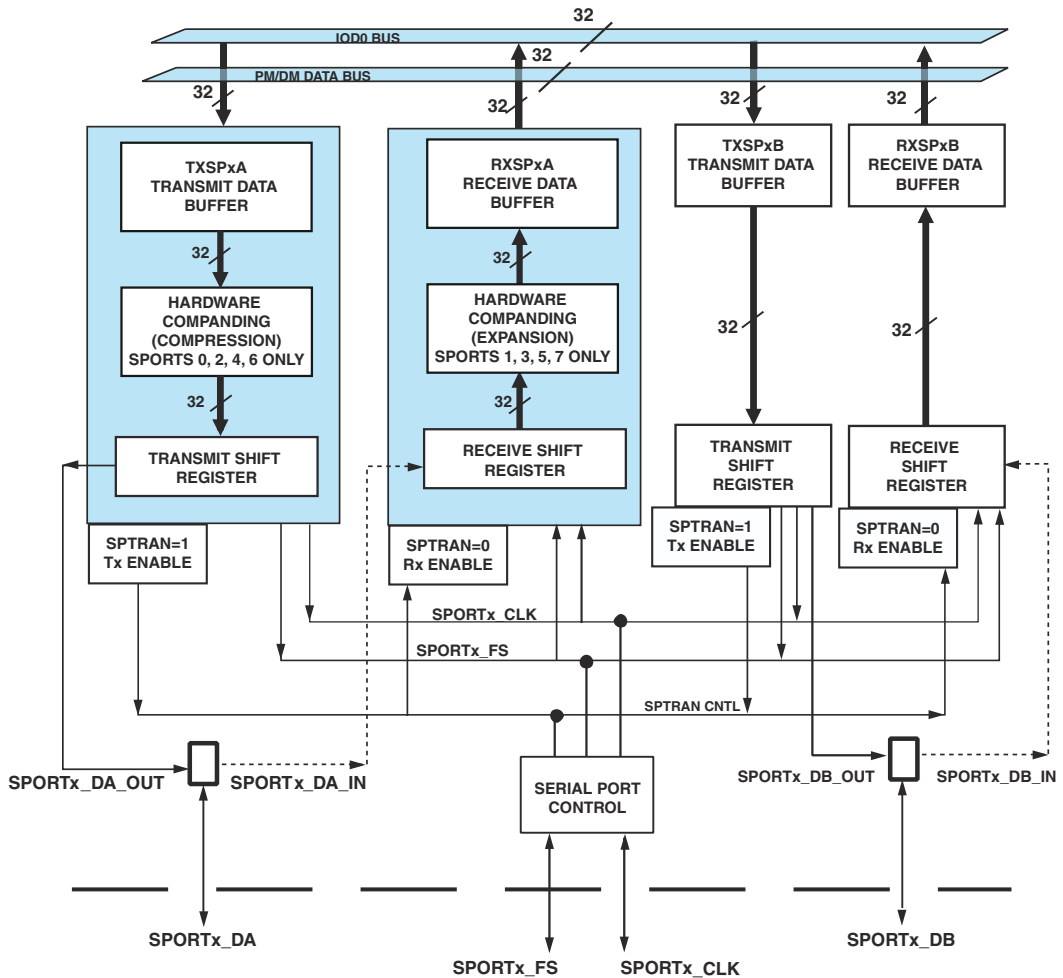



Figure 7-2. Serial Port Block Diagram

companding selected. If this bit is not set, the word contains zeros in the MSB positions. Companding is not supported for B channel. For B

Functional Description

channels, transmit or receive sign extension is selected by bit 0 of `DTYPE` in the `SPCTLx` register.

-  The compression for transmission requires a minimum word length of 8 (`SLEN = 8`) for proper function. If `SLEN < 8` the expansion may not work correctly.

Companding the Data Stream

Companding (compressing/expanding) is the process of logarithmically encoding and decoding data to minimize the number of bits that must be sent. The processor's serial ports support the two most widely used companding algorithms, A-law and μ -law, performed according to the CCITT G.711 specification. The type of companding can be selected independently for each `SPORT`. Companding is selected by the `DTYPE` field of the `SPCTLx` control register.

-  Companding is supported on the A channel only. `SPORT0`, 2, 4 and 6 primary channels are capable of compression, while `SPORTs` 1, 3, 5 and 7 primary channels are capable of expansion. In multichannel mode, when compression and expansion is enabled, the number of channels must be programmed via the `NCH` bit in the `SPMCTLx` registers before writing to the transmit buffer. The `SPxCSn` and `SPxCCSn` registers should also be written before writing to transmit buffer.

When companding is enabled, the data in the `RXSPxA` buffers is the right-justified, sign-extended expanded value of the eight received LSBs. A write to `TXSPxA` compresses the 32-bit value to eight LSBs (zero-filled to the width of the transmit word) before it is transmitted. If the 32-bit value is greater than the 13-bit A-law or 14-bit μ -law maximum, it is automatically compressed to the maximum value.

Transmit Path

If the serial port is configured as a serial transmitter, the data transmitted is written to the TXSPxA/TXSPxB buffer. The data is (optionally) companded in hardware on the primary A channel (SPORT 0, 2, 4 and 6 only), then automatically transferred to the transmit shift register, because companding is not supported on the secondary B channels. The data in the shift register is then shifted out via the SPORT's SPORTx_DA or SPORTx_DB signal, synchronous to the SPORTx_CLK clock. If framing signals are used, the SPORTx_FS signal indicates the start of the serial word transmission.

 The SPORTx_DA or SPORTx_DB signal is always driven if the serial port is enabled as transmitter (SPEN_A or SPEN_B = 1 in the SPCTLx control register), unless it is in multichannel mode and an inactive time slot occurs.

When the SPORT is configured as a transmitter (SPTRAN = 1), the TXSPxA and TXSPxB buffers, and the channel transmit shift registers respond to SPORTx_CLK and SPORTx_FS to transmit data. The receive RXSPxA and RXSPxB buffers, and the receive shift registers are inactive and do not respond to SPORTx_CLK and SPORTx_FS signals. Since these registers are inactive, reading from an empty buffer causes the core to hang indefinitely.

When the SPORT is configured as a transmitter (SPTRAN = 1), the transmit buffers are activated. The transmit buffers act like a two-location FIFO because they have one data registers plus an output shift register.

Receive Path

If the serial data signal is configured as a serial receiver (SPTRAN = 0), the receive portion of the SPORT shifts in data from the SPORTx_DA or SPORTx_DB signal, synchronous to the SPORTx_CLK receive clock. If framing signals are used, the SPORTx_FS signal indicates the beginning of the serial word being received. When an entire word is shifted in on the primary A

Functional Description

channel, the data is (optionally) expanded (SPORT1, 3, 5 and 7 only), then automatically transferred to the $RXSPxA$ buffer. When an entire word is shifted in on the secondary channel, it is automatically transferred to the $RXSPxB$ buffer.

When the SPORT is configured as a receiver ($SPTRAN = 0$), the $RXSPxA$ and $RXSPxB$ buffers, and the channel receive shift registers respond to $SPORTx_CLK$ and $SPORTx_FS$ for reception of data. The transmit $TXSPxA$ and $TXSPxB$ buffer registers and transmit A and B shift registers are inactive and do not respond to the $SPORTx_CLK$ and $SPORTx_FS$. Since the $TXSPxA$ and $TXSPxB$ buffers are inactive, writing to a transmit data buffer causes the core to hang indefinitely.

When the SPORT is configured as a receiver ($SPTRAN = 0$), the receive buffers are activated. The receive buffers act like a three-location FIFO because they have two data registers plus an input shift register.

Frame Sync

The following sections provide information on frame syncs which applies to the SPORTs in all operating modes. For mode-specific frame sync information, see [“Operating Modes” on page 7-20](#).

Frame Sync and Data Sampling

The information contained in this section is generic to the SPORTs in any operating mode. Additional information about frame syncs and data sampling that applies to a specific operating mode can be found in [“Operating Modes” on page 7-20](#).

As shown in [Figure 7-3](#) the SPORT uses two control signals to sample data.

1. Serial clock ($SCLK$) applies the bit clock for each serial data.
2. Frame sync (FS) divides the incoming data stream into frames.

Frames define the required data length (after the serial to parallel conversion) necessary to store the data in memory for further processing as shown in Figure 7-3. The transmitter for example drives clock and frame sync called master while the receiver is slave sampling these data (CKRE bit).

The transmitter drives the FS and data in on a falling edge. Therefore the receiver needs to sample the data on the opposite or rising edge.

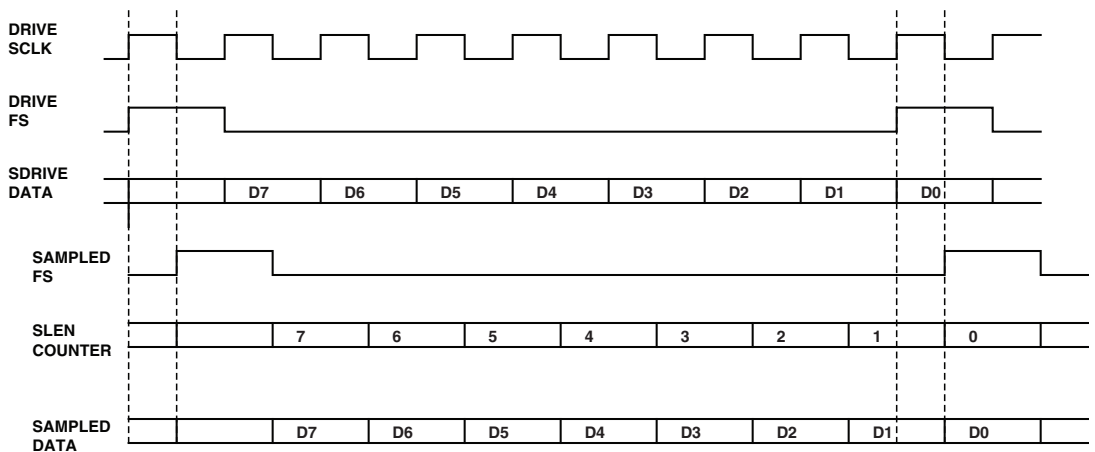

Figure 7-3. Frame Sync and Data Driven on Falling Edge

After the slave is sampled the FS the SLEN word counter is reloaded to the maximum setting. Each SCLK decrements the SLEN counter until the full frame is received. Since transmitter drives the frame sync and data on the falling edge the opposite edge is used to change the frame sync and data.

Serial Word Length

The serial word length is not unique and is based on the operation mode. Moreover the companding feature limits the word length settings.

Functional Description

Words smaller than 32 bits are right-justified in the receive and transmit buffers, residing in the least significant (LSB) bit positions (Table 7-4).

Table 7-4. Data Length versus Modes

Mode	Word Length (SLEN) bits
Standard Serial Mode	3–32
Left justified	8–32
I ² S	8–32
Packed	3–32
Multichannel	3–32

Internal Versus External Frame Syncs

Both transmit and receive frame syncs can be generated internally or input from an external source. The IFS/IMFS bit of the SPCTLx control register determines the frame sync source.

When IFS/IMFS is set (=1), the corresponding frame sync signal is generated internally by the processor, and the SPORTx_FS signal is an output. The frequency of the frame sync signal is determined by the value of the frame sync divisor (FSDIV) in the DIVx register.

When IFS/IMFS is cleared (=0), the corresponding frame sync signal is accepted as an input on the SPORTx_FS signals, and the frame sync divisors in the DIVx registers are ignored.

All frame sync options are available whether the signal is generated internally or externally.

Note that for I²S and left-justified mode, the MSTR bit allows programs to select only the clock and frame sync to be simultaneously configured as master or slave.

External Frame Sync Sampling

A variety of framing options are available on the SPORTs as shown in [Table 7-5](#).

 When the SPORT is enabled, an already active externally applied frame sync is not allowed to start operation. The SPORT waits for a valid state change from inactive to active for the external frame sync to consider it valid. This is true for the first valid frame after the SPORT is enabled and applicable to both level and edge sensitive frame syncs.

Table 7-5. Framing Options

OPMODE	External Frame Sync Sampling
Standard serial	Level sensitive
Left-justified pair	Edge detection
I ² S	Edge detection
Packed	Edge detection
Multichannel	Level sensitive

Signals: Level versus Edge Sampling

The SPORT slaves allow programs to sample the frame sync and data on its signal level or edges depending on the operation mode. Note that in a noise free environment it doesn't matter which sampling type is selected.

In noisy environments however, the edge based sampling is preferred as it allows better re-synchronization of the communication link.

Logic Level Frame Syncs

Frame sync signals may be active high or active low (for example, inverted). The LFS/LMFS bit in the SPCTLx registers selects the logic level of the frame sync signals as active low (inverted) if set (=1) or active high if cleared (=0). Active high (=0) is the default.

Operating Modes

Data-Independent Frame Sync

When $DIFS = 0$ and $SPTRAN = 1$, the internally-generated transmit frame sync is only output when a new data word has been loaded into the SPORT channel's transmit buffer. Once data is loaded into the transmit buffer, it is not transmitted until the next frame sync is generated. This mode of operation allows data to be transmitted only at specific times. When $DIFS = 0$ and $SPTRAN = 0$, a receive $SPORTx_FS$ signal is generated only when receive data buffer status is not full.

The data-independent frame sync mode allows the continuous generation of the $SPORTx_FS$ signal, with or without new data in the buffers. The $DIFS$ bit of the $SPCTLx$ control register configures this option. When $DIFS = 1$ and $SPTRAN = 1$, a transmit $SPORTx_FS$ signal is generated regardless of the transmit data buffer status. When $DIFS = 1$ and $SPTRAN = 0$, a receive $SPORTx_FS$ signal is generated regardless of the receive data buffer status.

For core transfers, the application is responsible for filling the transmit buffers with data. For DMA transfers, the SPORT DMA controller typically keeps the transmit buffer full.

Operating Modes

SPORTs operate in five modes:

- Standard serial mode, described in [“Standard Serial Mode” on page 7-24](#)
- Left-justified mode, described in [“Left-Justified Mode” on page 7-28](#)
- I²S mode, described in [“I²S Mode” on page 7-29](#)

- Packed mode, described in [“Packed Mode” on page 7-36](#)
- Multichannel mode, described in [“Multichannel Mode” on page 7-31](#)

 Bit names and their functionality change based on the SPORT operating mode. See the mode-specific section for the bit names and their functions.

 Pairings of SPORTs (0 and 1, 2 and 3, 4 and 5 and 6 and 7) are only used in loopback mode for testing.

The main control register for each serial port is the serial port control register, SPCTLx. These registers are described in [“Serial Port Registers” on page A-70](#).

 When changing operating modes, clear the serial port control register before the new mode is written to the register.

The SPCTLx registers control the operating modes of the serial ports. [Table 7-6](#) lists all the bits in the SPCTLx register.

Table 7-6. SPCTLx Control Bit Comparison

Bit	Standard Serial Mode	I ² S and Left-justified Mode	Packed Mode	Multichannel Mode
Control				
0	SPEN_A		Reserved	
1–2	DTYPE	Reserved	DTYPE	
3	LSBF	Reserved	LSBF	
4–8	SLEN			
9	PACK			
10	ICLK	MSTR	ICLK	
11	OPMODE			
12	CKRE	Reserved	CKRE	

Operating Modes

Table 7-6. SPCTLx Control Bit Comparison (Cont'd)

Bit	Standard Serial Mode	I ² S and Left-justified Mode	Packed Mode	Multichannel Mode
13	FSR	Reserved		
14	IFS	Reserved	IMFS	
15	DIFS		Reserved	
16	LFS	L_FIRST		LMFS
17	LAFS	OPMODE	Reserved	
18	SDEN_A			
19	SCHEN_A			
20	SDEN_B			
21	SCHEN_B			
22	FS_BOTH	Reserved		
23	BHD			
24	SPEN_B		Reserved	
25	SPTRAN			
Status				
26	DERR_B			
27–28	DXS_B			
29	DERR_A			
30–31	DXS_A			

Mode Selection

The serial port operating mode can be selected via the SPCTLx and the SPMCTLx/y registers.

1. The operating mode bit 11 (OPMODE) of the SPCTLx register selects between I²S, left-justified, and standard serial/multichannel mode.

2. The operating mode bit 17 (OPMODE) of the SPCTLx register selects between I²S mode and left-justified mode.
3. For packed mode, bit 11 (OPMODE) of the SPCTLx register and bit 0 (MCEA) in the SPMCTLx register enables the A channels and bit 23 (MCEB) in the SPMCTLx register enables the B channels.
4. In multichannel mode, the bit 0 (MCEA) in the SPMCTLx register enables the A channels and the bit 23 (MCEB) in the SPMCTLx register enables the B channels.
5. The OPMODE bit 17 serves for standard serial mode as late frame sync bit (LAFS).

The SPCTLx register is unique in that the name and functionality of its bits changes depending on the operation mode selected. In each section that follows, the bit names associated with the operating modes are described. [Table 7-7](#) provides values for each of the bits in the SPORT serial control (SPCTLx) registers that must be set in order to configure each specific SPORT operation mode. The shaded columns indicate that the bits come from different control registers.

Table 7-7. SPORT Operation Modes

OPERATING MODES (x = A or B or A and B SPORT Channels)	SPCTLx Bits			SPMCTLx Bits
	OPMODE (Bit 11)	OPMODE (Bit 17)	SPEN_x (Bit 0/24)	MCEx
Standard Serial Mode	0	Valid	1	0
Left-justified Mode	1	1	1	0
I ² S Mode	1	0	1	0
Packed Mode	1	0	0	1
Multichannel Mode	0	0	0	1

Operating Modes

The following sections provide detailed information on each operating mode available using the serial ports. It should be noted that many bits in the SPORT registers that control the function of the mode are the same bit but have a different name depending on the operating mode. Further, some bits are used in some modes but not others. For reference, see [Table 7-6 on page 7-21](#), [Table 7-7 on page 7-23](#), and [“Serial Port Registers” on page A-70](#).

Channel Order First

For left-justified, I²S and packed modes the next table demonstrates which word is transmitted or receive first depending on the L_FIRST bit.

Table 7-8. Channel Order First

OPMODE	L_FIRST = 0	L_FIRST = 1
Left-Justified	Data First After Rising Edge	Data First After Falling Edge
Packed	Data First After Falling Edge	Data First After Rising Edge
I ² S	Data First After Falling Edge	Data First After Rising Edge

Standard Serial Mode

The standard serial mode lets programs configure serial ports for use by a variety of serial devices such as serial data converters and audio CODECs. In order to connect to these devices, a variety of clocking, framing, and data formatting options are available.

Timing Control Bits

Several bits in the SPCTLx register enable and configure standard serial mode operation:

- Internal Clock (ICLK)
- Internal Frame Sync (IFS)

- Frame Sync Required (FSR)
- Sampling Edges Frame Sync/data (CKRE)
- Logic Level Frame Sync (LFS)
- Late Frame Sync (LAFS)
- Word length (SLEN, 3–32 bits)
- Word Order (LSBF)
- Word Packing (PACK)

Clocking Options

In standard serial mode, the serial ports can either accept an external serial clock or generate it internally. The ICLK bit in the SPCTL register determines the selection of these options. For internally-generated serial clocks, the CLKDIV bits in the DIVx register configure the serial clock rate.

Finally, programs can select whether the serial clock edge is used for sampling or driving serial data and/or frame syncs. This selection is performed using the CKRE bit in the SPCTL register.

Frame Sync Options

This section describes the different options for frame sync in standard serial mode.

Framed Versus Unframed Frame Syncs

The use of frame sync signals is optional in serial port communications. The FSR (transmit frame sync required) bit determines whether frame sync signals are required. Active low or active high frame syncs are selected using the LFS bit. This bit is located in the SPCTLx control registers.

Operating Modes

When `FSR` is set (`=1`), a frame sync signal is required for every data word. To allow continuous transmission from the processor, each new data word must be loaded into the transmit buffer before the previous word is shifted out and transmitted.

When `FSR` is cleared (`=0`), the corresponding frame sync signal is not required. A single frame sync is required to initiate communications but it is ignored after the first bit is transferred. Data words are then transferred continuously in what is referred to as an unframed mode.

i When DMA is enabled in a mode where frame syncs are not required, DMA requests may be held off by chaining or may not be serviced frequently enough to guarantee continuous unframed data flow.

Figure 7-4 illustrates framed serial transfers.

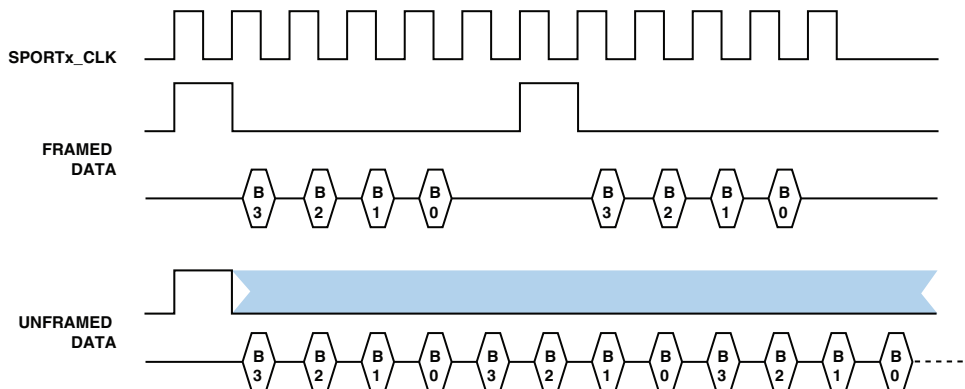

Figure 7-4. Framed Versus Unframed Data

Early Versus Late Frame Syncs

Frame sync signals can be early or late. Frame sync signals can occur during the first bit of each data word or during the serial clock cycle

immediately preceding the first bit. The `LAFS` bit of the `SPCTLx` control register configures this option.

When `LAFS` is cleared (`=0`), early frame syncs are configured. This is the normal mode of operation. In this mode, the first bit of the transmit data word is available (and the first bit of the receive data word is latched) in the serial clock cycle after the frame sync is asserted. The frame sync is not checked again until the entire word has been transmitted (or received). In multichannel operation, this is the case when the frame delay is one.

If data transmission is continuous in early framing mode (for example, the last bit of each word is immediately followed by the first bit of the next word), the frame sync signal occurs during the last bit of each word. Internally-generated frame syncs are asserted for one clock cycle in early framing mode.

When `LAFS` is set (`=1`), late frame syncs are configured. In this mode, the first bit of the transmit data word is available (and the first bit of the receive data word is latched) in the same serial clock cycle that the frame sync is asserted. In multichannel operation, this is the case when frame delay is zero. Receive data bits are latched by serial clock edges, but the frame sync signal is checked only during the first bit of each word. Internally-generated frame syncs remain asserted for the entire length of the data word in late framing mode. Externally-generated frame syncs are only checked during the first bit. They do not need to be asserted after that time period.

Operating Modes

Figure 7-5 illustrates the two modes of frame signal timing.

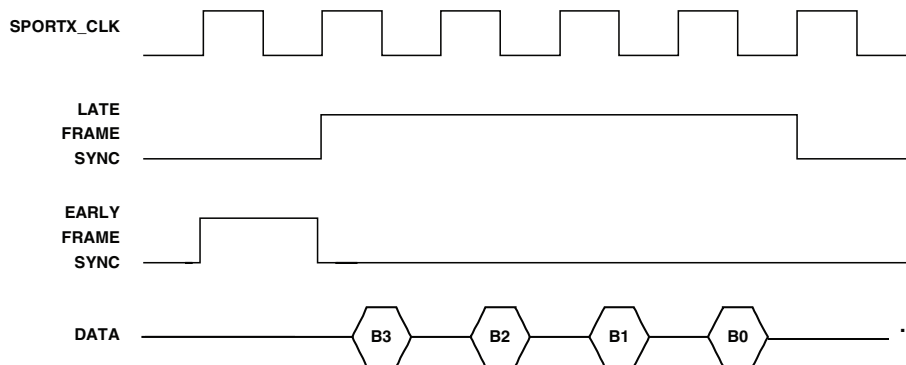

Figure 7-5. Normal Versus Alternate Framing

Left-Justified Mode

Left-justified mode is a mode where in each frame sync cycle two samples of data are transmitted/received—one sample on the high segment of the frame sync, the other on the low segment of the frame sync.

i Companding is not supported in left-justified or I²S mode.

Master Serial Clock and Frame Sync Rates

The serial clock rate (CLKDIV value) for internal clocks can be set using a bit field in the DIV_x register and the frame sync rate for internal frame sync can be set using the FSDIV bit field in the DIV_x register based on the MSTR bit setting.

The transmitter sends the MSB of the next word in the same clock cycle as the word select (SPORT_x_FS) signal changes.

To transmit or receive words continuously in left-justified mode, load the FSDIV register with SLEN-1. For example, for 8-bit data words set FSDIV = 7.

Timing Control Bits

Several bits in the SPCTLx control register enable and configure left-justified mode operation:

- Master Mode Clock and Frame Sync (MSTR)
- Word Length (SLEN, 8–32 bits)
- Channel Order (L_FIRST)
- Word Packing (PACK)

For complete descriptions of these bits, see [“Serial Control Registers \(SPCTLx\)”](#) on page A-71.

I²S Mode

The following sections provide information on using I²S mode.

Master Serial Clock and Frame Sync Rates

The serial clock rate (CLKDIV value) for internal clocks can be set using a bit field in the DIVx register and the frame sync rate for internal frame sync can be set using the FSDIV bit field in the DIVx register based on the MSTR bit setting.

The transmitter sends the MSB of the next word in the same clock cycle as the word select (SPORTx_FS) signal changes. To transmit or receive words continuously in I²S mode, load the FSDIV register with SLEN–1. For example, for 8-bit data words set FSDIV = 7.



Operating Modes

I²S Compatibility

-  The SPORTs are designed so that in I²S master mode, SPORTx_FS (used as an edge sensitive signal to select between the left and right channel) is held at the last driven logic level and does not transition, to provide an edge, after the final data word is driven out. Therefore, while transmitting a fixed number of words to an I²S receiver that expects a SPORTx_FS edge to receive the incoming data word, the SPORT should send a dummy word after transmitting the fixed number of words. The transmission of this dummy word toggles SPORTx_FS, generating an edge. Transmission of the dummy word is not required when the I²S receiver is a serial port.

Timing Control Bits

Several bits in the SPCTLx register enable and configure I²S mode operation:

- Master Mode Clock and Frame Sync (MSTR)
 - Sampling Edges Frame Sync/Data (CKRE)
 - Word length (SLEN, 8–32 bits)
 - Channel Order (L_FIRST)
 - Word Packing (PACK)
-  I²S mode is simply a subset of the left-justified mode. Note that in I²S mode, the data is delayed by one SCLK cycle and the operation transfer starts on the left channel first (L_FIRST = 1).
-  When both SPORT channels A and B are used in I²S/left-justified mode with standard DMA enabled, then the DMA count should be the same for both channels.

Multichannel Mode

The processor's serial ports offer a multichannel mode of operation, which allows the SPORT to communicate in a time division multiplexed (TDM) serial system. In multichannel communications, each data word of the serial bit stream occupies a separate channel. Each word belongs to the next consecutive channel. For example, a 24-word block of data contains one word for each of the 24 channels.

 Unlike previous SHARC processor the data direction in multichannel mode is no longer hard coded by SPORT multichannel pairing 0/1, 2/3, 4/5. Every SPORT can be used as transmitter or receiver with any other SPORT.

The serial port can automatically select some words for particular channels while ignoring others. Up to 128 channels are available for transmitting or receiving or both. Each SPORT can receive or transmit data selectively from any of the 128 channels.

Data companding and DMA transfers can also be used in multichannel mode on channel A. Channel B can also be used in multichannel mode, but companding is not available on this channel.

Although the eight SPORTs are programmable for data direction in the standard mode of operation, their programmability is restricted for multichannel operations. The following points summarize these limitations:

1. The primary A channels of SPORT1, 3, 5, and 7 are capable of expansion only, and the primary A channels of SPORT0, 2, 4, and 6 are capable of compression only.
2. Receive comparison is not supported.

Clocking Options

In multichannel mode, the serial ports can either accept an external serial clock or generate it internally. The ICLK bit in the SPCTL register

Operating Modes

determines the selection of these options. For internally-generated serial clocks, the `CLKDIV` bits in the `DIVx` register configure the serial clock rate. Finally, programs can select whether the serial clock edge is used for sampling or driving serial data and/or frame syncs. This selection is performed using the `CKRE` bit in the `SPCTL` register.

Frame Sync Options

In previous SHARC processors, multichannel mode required a `SPORT` pair. This pair was needed to route the `SCLK` on the even `SPORT` and the frame sync to the odd `SPORT`. The pair itself interconnect the `SCLK` and `FS` signals.

 Multichannel mode in the ADSP-21367/8/9 and ADSP-2137x processors operate completely independently and each uses its own `SCLK` and `FS` signal programmed using the `SRU`. The `FS` signal synchronizes the channels and restarts each multichannel sequence. The `SPORTx_FS` signal initiates the start of the channel 0 data word. The `FS` period in multichannel is defined as:
$$\text{FS period} = \text{SLEN} \times \text{number of channels.}$$
 The frame sync can be configured in master or slave mode based on the setting of the `IMFS` bit and the logic level can be changed using the `LMFS` bit.

Frame Sync Delay (MFD)

The 4-bit `MFD` field (bits 4–1) in the multichannel control registers (`SPMCTLX`) specifies a delay between the frame sync pulse and the first data bit in multichannel mode. The value of `MFD` is the number of serial clock cycles of the delay. Multichannel frame delay allows the processor to work with different types of telephony interface devices.

A value of zero for `MFD` causes the frame sync to be concurrent with the first data bit. The maximum value allowed for `MFD` is 15. A new frame sync may occur before data from the last frame has been received, because blocks of data occur back to back.

Transmit Data Valid Signal

In the ADSP-21367/8/9 and ADSP-2137x processors, each SPORT has its own transmit data valid signal ($SPORTx_TDV_0$) which is active during the transmission of an enabled word. Because the serial port's receiver signals are three-stated when the time slot is not active, the $SPORTx_TDV_0$ signal specifies if the SPORT data is being driven by the processor.

After the $TXSPxA$ transmit buffer is loaded, transmission begins and the $SPORTx_TDV$ signal is asserted. When SPORT DMA is used, this signal may occur several cycles after the multichannel transmission is enabled. If a deterministic start time is required, pre-load the transmit buffer.

Figure 7-6 shows an example of timing for a multichannel transfer with SPORT pairing using SPORT0 and 1. The transfer has the following characteristics.

- SPORT1–0 have the same $SCLK$ and FS as input
- Multichannel configured as 8 channels
- SPORT0A drives data to DAC1 during slot 1–0 which asserts TDV for 2 slots
- SPORT1A drives data to DAC2 during slot 3–2 which asserts TDV for 2 slots
- SPORT1B receives data from ADC during slot 3–0

Operating Modes

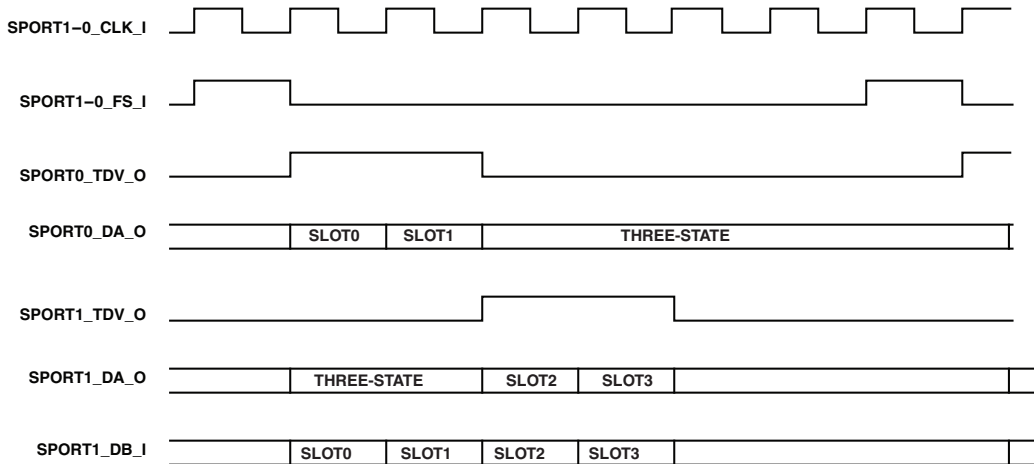

Figure 7-6. Multichannel Operation

Transmit Data Valid Output

In the ADSP-21367/8/9 and ADSP-2137x processors, each SPORT has its own transmit data valid output signal ($SPORTx_TDV_0$) which is active during the transmission of an enabled word. Because the serial port's receiver signals are three-stated when the time slot is not active, the $SPORTx_TDV_0$ signal specifies if the SPORT data is being driven by the processor.

Unlike previous ADSP-2136x SHARC processors, the assertion of the $SPORTx_TDV_0$ is independent for the transmit buffer status (valid data or not). So writing to the buffer does not affect the $SPORTx_TDV_0$ output timing.

Timing Control Bits

The following bits in the `SPCTLx` register are used to configure timing options in multichannel mode.

- Frame Delay (`MFD`)
- Number of Channels (`NCH`)
- Internal Clock (`ICLK`)
- Internal Frame Sync (`IMFS`)
- Sampling Edges Frame Sync/Data (`CKRE`)
- Logic Level Frame Sync (`LMFS`)
- Word Length (`SLEN`, 8–32 bits)
- Word Order (`LSBF`)
- Word Packing 16 to 32 (`PACK`)

Number of Channels (NCH)

Select the number of channels used in multichannel operation by using the 7-bit `NCH` field in the multichannel control register. Set `NCH` to the actual number of channels minus one:

- $NCH = \text{Number of channels} - 1$

The 7-bit `CHNL` field in the multichannel control registers indicates the channel that is currently selected during multichannel operation. This field is a read-only status indicator. The `CHNL(6:0)` bits increment modulo `NCH(6:0)` as each channel is serviced.

Operating Modes

Packed Mode

A packed mode is available in the SPORT and used for audio codec communications using multiples channels. This mode allows applications to send more than the standard 32 bits per channel available through standard I²S mode. Packed mode is implemented using standard multichannel mode (and is therefore programmed similarly to multichannel mode). Packed mode also supports the maximum of 128 channels as does multichannel mode as well as the maximum of (128 x 32) bits per left or right channel.

As shown in [Figure 7-7](#), packed waveforms are the same as the wave forms used in multichannel mode, except that the frame sync is toggled for every frame, and therefore emulates I²S mode. So it is a hybrid between multichannel and I²S mode.

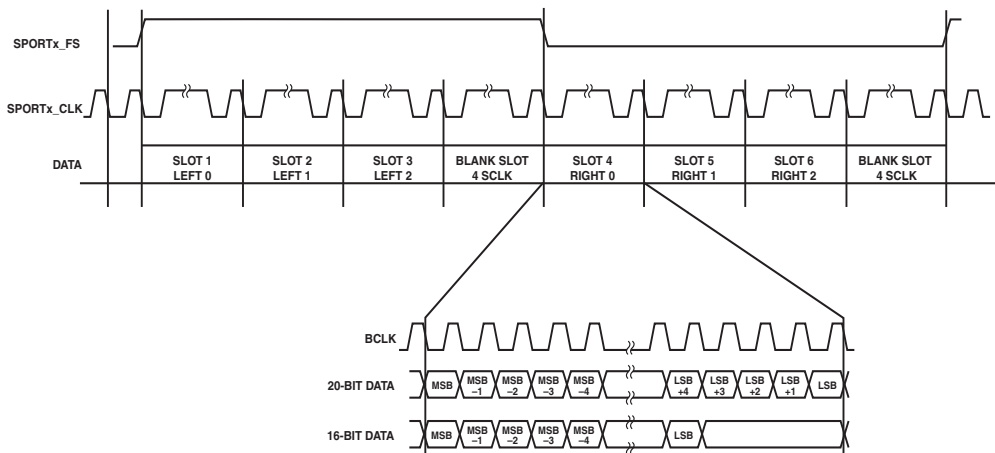

Figure 7-7. Packed Mode 128 Operation

Clocking Options

In packed mode, the serial ports can either accept an external serial clock or generate it internally. The `ICLK` bit in the `SPCTL` register determines the selection of these options. For internally-generated serial clocks, the `CLK-DIV` bits in the `DIVx` register configure the serial clock rate. Finally, programs can select whether the serial clock edge is used for sampling or driving serial data and/or frame syncs. This selection is performed using the `CKRE` bit in the `SPCTL` register.

Frame Sync Options

The frame sync period in packed mode is defined as:

FS period = $SLEN \times \text{number of channels}$.

The frame sync can be configured in master or slave mode depending on the `IMFS` bit. Moreover the logic level can be changed with the `LMFS` bit.

Timing Control Bits

Several bits in the `SPCTLx` register enable and configure packed mode.

- Internal Clock (`ICLK`)
- Internal Frame Sync (`IFS`)
- Sampling Edges Frame Sync/Data (`CKRE`)
- Selecting Channel Order (`L_FIRST`)
- Word Length (`SLEN`, 8–32 bits)
- Word Order (`LSBF`)
- Word Packing (`PACK`)

Operating Modes

The following bits in the `SPMCTLx` register are used to configure timing options in packed mode.

- Frame Delay (`MFD`)
- Number of multichannel channels (`NCH`)

Active Channel Selection Registers

Specific channels can be individually enabled or disabled to select the words that are received and transmitted during multichannel communications. Data words from the enabled channels are received or transmitted, while disabled channel words are ignored. Up to 128 channels are available for transmitting and receiving.

The multichannel selection registers enable and disable individual channels. The registers for each serial port are shown in [“Serial Port Registers” on page A-70](#).

Each of the four multichannel enable and compand select registers are 32 bits in length. These registers provide channel selection for 128 (32 bits x 4 channels = 128) channels. Setting a bit enables that channel so that the serial port selects its word from the multiple-word block of data (for either receive or transmit). For example, setting bit 0 for TX SPORT0 and TX SPORT7 (`MT0CS0` or `MT7CS0`) selects channel 0, setting bit 12 selects channel 12, and so on. Setting bit 0 for TX SPORT0 and TX SPORT7 (`MT0CS1` or `MT7CS1`) selects channel 32, setting bit 12 selects channel 44, and so on.

Transmit Selection Registers

Setting a particular bit to 1 in the to 1 in the `MTxCSy` registers causes `SPORTx` to transmit the word in that channel’s position of the data stream. Clearing the bit in the register causes the `SPORTx_DA` data transmit signal to three-state during the time slot of that channel if the SPORT is

configured as transmitter. If the SPORT is configured as receiver, the data received is ignored.

Receive Selection Registers

Setting a particular bit to 1 in the $MRxCSy$ registers causes the serial port to receive the word in that channel's position of the data stream. The received word is loaded into the receive buffer. Clearing the bit in the register causes the serial port to ignore the data.

Companding Selection

Companding may be selected on a per-channel basis. Setting a bit to 1 in any of the multichannel registers ($MTxCCSy$ or $MRxCCSy$) specifies that the data be companded for that channel. A-law or μ -law companding can be selected using the $DTYPE$ bit in the $SPCTLx$ control registers. $SPORTA1$, 3, 5 and 7 expand selected incoming time slot data, while $SPORTA0$, 2, 4 and 6 can compress the data.

Companding Limitations

In multichannel mode there is an option to enable companding for any active channel. If the first active channel is NOT the channel 0 and companding is enabled for the first active channel (channel 2), then from the second frame onward companding for the first active channel (channel 2) does not occur. In [Table 7-9](#): x = Don't care 0 = not active 1 = active.

Table 7-9. Companding

Channel Number	0	1	2	3	4	5
Active Channel Number	0	0	1	x	x	x
Companding Enable	0	0	1	x	x	x

In [Table 7-9](#) channel 0 and 1 are not active and channel 2 is active and companding is enabled. In the first frame companding occurs for the first

Data Transfer Types

active channel (channel 2) but the second frame onward companding for the first active channel (channel 2) does not occur. However, for other channels, companding occurs correctly.

Data Transfer Types

Serial port data can be transferred for use by the processor in two different methods:

- Core-driven single word transfers
- DMA transfers between both internal and external memory

DMA transfers can be set up to transfer a configurable number of serial words between the serial port buffers (TXSPxA, TXSPxB, RXSPxA, and RXSPxB) and internal memory automatically. Core-driven transfers use SPORT interrupts to signal the processor core to perform single word transfers to/from the serial port buffers (TXSPxA, TXSPxB, RXSPxA, and RXSPxB).

Data Buffers

When programming the serial port channel (A or B) as a transmitter, only the corresponding TXSPxA and TXSPxB buffers become active while the receive buffers RXSPxA and RXSPxB remain inactive. Similarly, when the SPORT channel A and B are programmed as receive-only the corresponding RXSPxA and RXSPxB are activated. Do not attempt to read or write to inactive data buffers. If the processor operates on the inactive transmit or receive buffers while the SPORT is enabled, unpredictable results may occur.

 Word lengths of less than 32 bits are automatically right-justified in the receive and transmit buffers.

Transmit Buffers (TXSPxA/B)

The transmit buffers (TXSP7-0A, TXSP7-0B) are the 32-bit transmit data buffers for SPORT7–0 respectively. These buffers must be loaded with the data to be transmitted if the SPORT is configured to transmit on the A and B channels. The data is loaded automatically by the DMA controller or loaded manually by the program running on the processor core.

The transmit buffers act like a two-location buffer because they have a data register plus an output shift register. Two 32-bit words may both be stored in the transmit queue at any one time. When the transmit register is loaded and any previous word has been transmitted, the register contents are automatically loaded into the output shifter. An interrupt occurs when the output transmit shifter has been loaded, signifying that the transmit buffer is ready to accept the next word (for example, the transmit buffer is not full). This interrupt does not occur when serial port DMA is enabled or when the corresponding mask bit in the LIRPTL/IRPTL register is set.

Receive Buffers (RXSPxA/B)

The receive buffers (RXSP7-0A, RXSP7-0B) are the 32-bit receive data buffers SPORT7–0 respectively. These 32-bit buffers become active when the SPORT is configured to receive data on the A and B channels. When a SPORT is configured as a receiver, the RXSPxA and RXSPxB registers are automatically loaded from the receive shifter when a complete word has been received. The data is then loaded to internal memory by the DMA controller or read directly by the program running on the processor core.



Buffer Status

Serial ports provide status information about data buffers via the DXS_A and DXS_B status bits and error status via DERR_x bits in the SPCTL register. Depending on the SPTRAN setting, these bits reflect the status of either the TXSPxy or RXSPxy data buffers.

Data Transfer Types

If your program causes the core processor to attempt to read from an empty receive buffer or to write to a full transmit buffer, the access is delayed until the buffer is accessed by the external I/O device. This delay is called a core processor hang. If you do not know if the core processor can access the receive or transmit buffer without a hang, the buffer's status should be read first (in `SPCTLx`) to determine if the access can be made.

Two complete 32-bit words can be stored in the receive buffer while a third word is being shifted in. The third word overwrites the second if the first word has not been read out (by the processor core or the DMA controller). When this happens, the receive overflow status bit is set in the serial port control register. Almost three complete words can be received without the receive buffer being read before an overflow occurs. The overflow status is generated on the last bit of the third word. The `DERR_x` status bits are sticky and are cleared only by disabling the serial port.

-  If the SPORTs are configured as transmitters, programs should not write to the inactive `TXSPxA` and `TXSPxB` buffers. If the core keeps writing to the inactive buffer, the transmit buffer status becomes full. This causes the core to hang indefinitely since data is never transmitted to the output shift register.
-  If the SPORTs are configured as receivers, programs should not read from the inactive `RXSPxA` and `RXSPxB` buffers. If the core keeps reading from the inactive buffer, the receive buffer status becomes empty. This causes the core to hang indefinitely since new data is never received via the input shift register.
-  The status bits in `SPCTLx` are updated during reads and writes from the core processor even when the serial port is disabled. Disable the serial port when writing to the receive buffer or reading from the transmit buffer.

Data Buffer Packing

Received data words of 16 bits or less may be packed into 32-bit words, and 32-bit words being transmitted may be unpacked into 16-bit words. Word packing and unpacking is selected by the `PACK` bit in the `SPCTLx` control registers.

When `PACK = 1` in the control register, two successive words received are packed into a single 32-bit word, and each 32-bit word is unpacked and transmitted as two 16-bit words. The first 16-bit (or smaller) word is right-justified in bits 15–0 of the packed word, and the second 16-bit (or smaller) word is right-justified in bits 31–16. This applies to both receive (packing) and transmit (unpacking) operations. Companding can be used with word packing or unpacking.

When serial port data packing is enabled, the transmit and receive interrupts are generated for the 32-bit packed words, not for each 16-bit word.

 When 16-bit received data is packed into 32-bit words and stored in normal word space in processor internal memory, the 16-bit words can be read or written with short word space addresses

Core Transfers

The following sections provide information on core driven data transfers.

Single Word Transfers

Individual data words may also be transmitted and received by the serial ports, with interrupts occurring as each 32-bit word is transmitted or received. When a serial port is enabled and DMA is disabled, the `SPORT` interrupts are generated whenever a complete 32-bit word has been received in the receive buffer, or whenever the transmit buffer is not full.

When performing core-driven transfers, write to the buffer designated by the `SPTRAN` bit setting in the `SPCTLx` register. If the inactive `SPORT` data

Data Transfer Types

buffers are read or written to by core while the port is being enabled, the core hangs. For example, if a SPORT is programmed to be a transmitter, while at the same time the core reads from the receive buffer of the same SPORT, the core hangs just as it would if it were reading an empty buffer that is currently active. This locks up the core until the SPORT is reset.

To avoid hanging the processor core, check the buffer's full/empty status when the processor core's program reads a word from a serial port's receive buffer or writes a word to its transmit buffer. This condition can also happen to an external device, for example a host processor, when it is reading or writing a serial port buffer. The full/empty status can be read in the `DXS` bits of the `SPCTLx` register. Reading from an empty receive buffer or writing to a full transmit buffer causes the processor (or external device) to hang, while it waits for the status to change.

Frame Sync Generation

The frame syncs are generated if the transmit or receive buffers are updated according to the `DIFS` bit setting (`=0`). If there is no buffer update by the core, the frame sync out is not driven off-chip and data output is zero.

If both A and B channels are enabled, one of the following can occur.

- In standard mode the `FS_BOTH` bit (in the `SPCTLx` register) defines the conditions of whether both channels are logically AND'ed or OR'ed.
- For all other operating modes, channels A and B are logically AND'ed. If both channels are enabled, both buffers need to be updated to drive data and frame sync off-chip.

Note that for all operating modes, if the `DIFS` bit is set, all conditions are overridden. The frame sync is driven off-chip and the data output are zero with the `DERRx` bit set.

Internal Memory DMA Transfers

SPORT DMA provides a mechanism for receiving or transmitting an entire block of serial data before the interrupt is generated. When serial port DMA is not enabled, the SPORT generates an interrupt every time it receives or starts to transmit a data word. The processor's on-chip DMA controller handles the DMA transfer, allowing the processor core to continue running until the entire block of data is transmitted or received. Service routines can then operate on the block of data rather than on single words, significantly reducing overhead.

Therefore, set the direction bit, the serial port enable bit, and DMA Enable bits before initiating any operations on the SPORT data buffers. If the processor operates on the inactive transmit or receive buffers while the SPORT is enabled, it can cause unpredictable results.

Each transmitter and receiver has its own DMA registers. The same DMA channel drives the left and right I²S channels for the transmitter or the receiver. The software application must stop multiplexing the left and right channel data received by the receive buffer, because the left and right data are interleaved in the DMA buffers.

Channel A and B on each SPORT share a common interrupt vector. The DMA controller generates an interrupt at the end of DMA transfer only.

[Figure 7-5 on page 7-28](#) shows the relationship between frame sync (word select), serial clock, and I²S data. Timing for word select is the same as for frame sync.

The value of the `SPTRAN` bit in `SPCTLx` (0 = RX, 1 = TX) determines whether the receive or transmit register for the SPORT becomes active.

The SPORT DMA channels are assigned higher priority than all other DMA channels (for example, the SPI port) because of their relatively low service rate and their inability to hold off incoming data. Having higher priority causes the SPORT DMA transfers to be performed first when

Data Transfer Types

multiple DMA requests occur in the same cycle. The serial port DMA channels are numbered and prioritized as shown in [Table 2-22 on page 2-32](#).

Although the DMA transfers are performed with 32-bit words, serial ports can handle word sizes from 3 to 32 bits, with 8 to 32 bits for I²S mode. If serial words are 16 bits or smaller, they can be packed into 32-bit words for each DMA transfer. DMA transfers are configured using the `PACK` bit in the `SPCTLx` registers. When serial port data packing is enabled (`PACK = 1`), the transmit and receive interrupts are generated for the 32-bit packed words, not for each 16-bit word.

Standard DMA

Each SPORT DMA channel has an enable bit (`SDEN_A` and `SDEN_B`) in its `SPCTLx` register. When DMA is disabled for a particular channel, the SPORT generates an interrupt every time it receives a data word or whenever there is a vacancy in the transmit buffer. For more information, see [“Single Word Transfers” on page 7-43](#).

To set up a serial port DMA channel, write a set of memory buffer parameters to the SPORT DMA parameter registers as shown in [Table 2-22 on page 2-32](#).

Load the `II`, `IM`, and `C` registers with a starting address for the buffer, an address modifier, and a word count, respectively. The index register contains the internal memory address for transfers to internal memory and the external memory address for transfers to external memory. These registers can be written from the core processor or from an external processor.

Once serial port DMA is enabled, the processor’s DMA controller automatically transfers received data words in the receive buffer to the buffer in internal or external memory, depending on the transfer type. Likewise, when the serial port is ready to transmit data, the DMA controller automatically transfers a word from internal or external memory to the

transmit buffer. The controller continues these transfers until the entire data buffer is received or transmitted.

When the count register of an active DMA channel reaches zero (0), the SPORT generates the corresponding interrupt.

DMA Chaining

Each channel also has a DMA chaining enable bit (SCHEN_A and SCHEN_B) in its SPCTLx control register.

Each SPORT DMA channel also has a chain pointer register (CPSPxy). The CPSPxy register functions are used in chained DMA operations.

In chained DMA operations, the processor's DMA controller automatically sets up another DMA transfer when the contents of the current buffer have been transmitted (or received). The chain pointer register (CPSPxy) functions as a pointer to the next set of buffer parameters stored in external or internal memory. The DMA controller automatically downloads these buffer parameters to set up the next DMA sequence. For more information on SPORT DMA chaining, see [“DMA Chaining” on page 2-27](#).

DMA chaining occurs independently for the transmit and receive channels of each serial port. Each SPORT DMA channel has a chaining enable bit (SCHEN_A or SCHEN_B) that when set (= 1), enables DMA chaining and when cleared (= 0), disables DMA chaining. Writing all zeros to the address field of the chain pointer register (CPSPxy) also disables chaining.

 The chain pointer register should be cleared first before chaining is enabled.

The I/O processor responds by auto-initializing the first DMA parameter registers with the values from the first TCB, and then starts the first data transfer.

Data Transfer Types



Although the word lengths can be 3 to 32 bits, transmitting or receiving words smaller than 7 bits at the full clock rate of the serial port may cause incorrect operation when DMA chaining is enabled. Chaining locks the processor's internal I/O bus for several cycles while the new transfer control block (TCB) parameters are being loaded. Receive data may be lost (for example, overwritten) during this period. Moreover, transmitting or receiving words smaller than five bits may cause incorrect operation when all the DMA channels are enabled with no DMA chaining.

DMA Chain Insertion Mode

It is possible to insert a single SPORT DMA operation or another DMA chain within an active SPORT DMA chain. Programs may need to perform insertion when a high priority DMA requires service and cannot wait for the current chain to finish.

When DMA on a channel is disabled and chaining on the channel is enabled, the DMA channel is in chain insertion mode. This mode allows a program to insert a new DMA or DMA chain within the current chain without effecting the current DMA transfer.

Chain insertion mode operates the same as non-chained DMA mode. When the current DMA transfer ends, an interrupt request occurs and no TCBs are loaded. This interrupt request is independent of the `PCI` bit state.

Chain insertion should not be set up as an initial mode of operation. This mode should only be used to insert one or more TCBs into an active DMA chaining sequence. For more information, see [“Enter DMA Chain Insertion Mode” on page 7-57](#).

Frame Sync Generation

The frame syncs are generated if the transmit or receive buffers are updated according to the `DIFS` bit setting (=0). The SPORT DMA controller ensure that the data buffers are updated accordingly.

If both A and B channels are enabled, one of the following can occur.

- In standard mode the `FS_BOTH` bit (in the `SPCTLx` register) defines the conditions of whether both channels are logically AND'ed or OR'ed.
- For all other operating modes, channels A and B are logically AND'ed. If both channels are enabled, both buffers need to be updated by the DMA controller to drive data and frame sync off-chip.

Note that for all operating modes, if the `DIFS` bit is set and the DMA transfers have completed, the frame sync continues to drive off-chip and the data output are zero with the `DERRx` bit set.

Interrupts

This section handles the various scenarios in which an interrupt is triggered. Both the core and DMA are able to generate data interrupts for receive or transmit operations. Moreover, the SPORT modules generate error conditions which generate a separate interrupt.

[Table 7-10](#) provides an overview of SPORT interrupts.

Interrupts

Table 7-10. SPORT Interrupt Overview

Interrupt Source	Interrupt Condition	Interrupt Completion	Interrupt Acknowledge	Default IVT
SPORT (standard, I2S, left justified, packed, multichannel, 16 channels)	<ul style="list-style-type: none">– DMA RX/TX done– Core RX buffer full– Core TX buffer empty– DMA under/overflow error– Frame sync error	Internal transfer completion	RTI instruction	P3I–P8I, P11I, P16I, SPERRI

Internal Transfer Completion

Each serial port has an interrupt associated with it. For each SPORT, both the A and B channel transmit and receive data buffers share the same interrupt vector. The interrupts can be used to indicate the completion of the transfer of a block of serial data when the serial ports are configured for DMA. They can also be used to perform single word transfers (refer to “[Single Word Transfers](#)” on page 7-43). The priority of the serial port interrupts is shown in [Table 2-23 on page 2-42](#).

Multiple interrupts can occur if both SPORTs transmit or receive data in the same cycle. Any interrupt can be masked in the IMASK register; if the interrupt is later enabled in the LIRPTL register, the corresponding interrupt latch bit in the IRPTL or LIRPTL registers must be cleared in case the interrupt has occurred in the same time period.

 SPORT interrupts occur on the second peripheral clock (PCLK) after the last bit of the serial word is latched in or driven out.

When serial port data packing is enabled (PACK = 1 in the SPCTLx registers), the transmit and receive interrupts are generated for 32-bit packed words, not for each 16-bit word.

Each DMA channel has a count register (CSPxA/CSPxB), which must be initialized with a word count that specifies the number of words to transfer. The count register decrements after each DMA transfer on the

channel. When the word count reaches zero, the SPORT generates an interrupt, then automatically stops the DMA channel.

Shared Channels

Both the A and B channels share a common interrupt vector in the interrupt-driven data transfer mode, regardless of whether they are configured as a transmitter or receiver.

The SPORT generates an interrupt when the transmit buffer has a vacancy or the receive buffer has data. To determine the source of an interrupt, applications must check the transmit or receive data buffer status bits (DXS_A, DXS_B) in SPCTLx registers and for DMA the corresponding status bits in the SPMCTLx registers. However note in most cases if both channels are enabled with the same DMA count, there is no need to check the status since both channel interrupts are close to each other.

 Standard DMA does not function properly in I²S/left-justified mode when two channels (A and B) are enabled with different DMA count values. In this case, the interrupt is generated for the least count only. If both the A and B channels of the SPORTs are used in I²S/left-justified mode with DMA enabled, then the DMA count value should be the same for both channels. This does not apply to chained DMA.

Error Detection

Similar to previous SHARC processors, the SPORTs can return the status of data buffer underflow and overflow conditions. Additionally, the SPORTs can also detect frame syncs that are occurring early, even before the last transmit or receive completes. To detect these errors, the processor has an error interrupt (SPERRI vector interrupt) that is shared for all SPORTs together. It is triggered on a data underflow, data overflow, or frame sync error in their respective channels. An interrupt is triggered and programs simply read the SPERRSTAT register which reduces the processor

Interrupts

overhead needed to do register polling. If the interrupt enable bit `SPERRI` is set then the interrupt is raised when the error occurs. Otherwise, the errors are latched and no interrupt is generated.

As shown in [Figure 7-8](#), the frame sync error (which sets the error bit) is triggered when an early frame sync occurs during data transmission or reception or for late frame sync if the period of the frame sync is smaller than the serial word length (`SLEN`). However, the current transmit/receive operation continues without interruption.

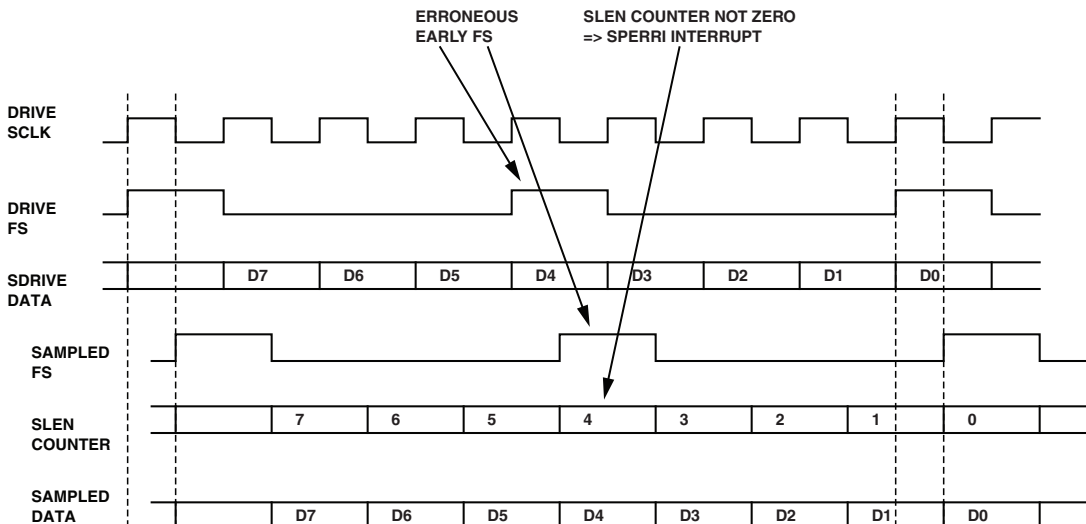

Figure 7-8. Frame Sync Error Detection

When a serial port is receiving or transmitting, its bit count is set to a word length (for example 32 bits). After each clock edge the bit count is decremented. After the word is received/transmitted the bit count reaches zero, and on next frame sync it is set to 32. When active transmission or reception is occurring, the bit count value is non-zero. When a frame sync with a bit count of non-zero is detected, a frame sync error occurs.

Note that a frame sync error is not detected in following cases.

- When there is no active data transmit/receive and the frame sync pulse occurs due to noise in the input signal. This is considered a valid frame sync.
- If there is a underflow or overflow error. SPORT error logic does not run (the bit count is not set and decremented) if there is an underflow error. Therefore, frame sync errors can not be detected.
- When the frame sync pulse $<$ SCLK period.
- In late frame sync mode if the frame sync pulse is not active during the whole transmission/reception a frame sync error is generated.

Error Status

Each SPORT can generate an interrupt if a DERR_A, DERR_B, or FSYNC_ERR error occurs. The SPERRCTLx registers control and report the status of the interrupts generated by each SPORT.

SPORT sticky error bits can be cleared in two ways:

1. By disabling the SPORT (frame sync error) or disabling the corresponding channel by itself (for DERR_A, DERR_B).
2. By writing a 1 to the interrupt status bits in the SPERRCTLx register. When sticky bits are cleared, interrupts are also cleared.

Only one error interrupt is connected for all serial ports together. So when an error occurs the programs should read the sticky status bits and detect which interrupt caused the error.

An additional register is provided to read all sport interrupt status bits together. The SPERRSTAT register shows the status of all SPORT error interrupts. This register also shows the latched interrupt status, but only when the interrupt is enabled for that error.

Debug Features

The following sections provide information on debugging features available with the serial ports.

SPORT Loopback

When the SPORT loopback bit, `SPL` (bit 12), is set in the `SPMCTLx` register, the serial port is configured in an internal loopback connection as follows: SPORT0/SPORT1 work as a pair, SPORT2/SPORT3 work as a pair, and SPORT4/SPORT5 work as a pair, SPORT6/SPORT7 work as a pair.

 The `SPL` bit applies to all non multichannel modes.

The loopback mode enables programs to test the serial ports internally and to debug applications.

In loopback mode, either of the two paired SPORTS can be transmitters or receivers. One SPORT in the loopback pair must be configured as a transmitter; the other must be configured as a receiver. For example, SPORT0 can be a transmitter and SPORT1 can be a receiver for internal loopback. Or, SPORT0 can be a receiver and SPORT1 can be the transmitter when setting up internal loopback.

LoopBack Routing

The SPORTs support an internal loopback mode by using the SRU. [For more information, see “Loop Back Routing” on page 6-41.](#)

Buffer Hang Disable (BHD)

To support debugging buffer transfers, the processors have a buffer hang disable (BHD) bit. When set (= 1), this bit prevents the processor core from detecting a buffer-related stall condition, permitting debugging of this type of stall condition.

Effect Latency

The total effect latency is a combination of the write effect latency (core access) plus the peripheral effect latency (peripheral specific).

Write Effect Latency

For details on write effect latency, see *SHARC Processor Programming Reference*.

SPORT Effect Latency

After a write to a SPORT control register, control and mode bit changes take effect in the second serial clock cycle (SCLK).

The SPORT is ready to start transmitting or receiving three serial clock cycles after they are enabled in the SPCTLX control register. No serial clocks are lost from this point on. This delay does also apply in slave mode (external clock/frame sync) for synchronization.

Multichannel and packed operation is activated 3 serial clock cycles (SCLK) after the MCEA or MCEB bits are set. Internally-generated frame sync signals activate 4 serial clock cycles after the MCEA or MCEB bits are set.

Programming Model

The section describes some programming procedures that are used to enable and operate the SPORTs.

Setting Up and Starting DMA Master Mode

To set up and initiate a master DMA operation, use the following procedure.

1. Clear the SPORT control register (SPCTLx).
2. Write to the appropriate DIVx register, setting the master clock and frame sync ratios.
3. Configure all DMA parameter registers (index, modify and count).
4. Configure the SPORT operation mode and enable DMA operation (SPCTLx).

Setting Up and Starting Chained DMA

To set up and initiate a chain of DMA operations, use the following procedure.

1. Clear the chain pointer register.
2. For internal memory transfers, set up all TCBs in internal memory.
3. Write the address containing the index register value of the first TCB to the chain pointer register, which starts the chain.
4. Write to the SPCTLx register by setting the DMA enable bit to one and the chaining enable bit to one. Setting these bits loads the DMA parameter registers.

Enter DMA Chain Insertion Mode

Chain insertion lets the SPORTs insert a single SPORT DMA operation or another DMA chain within an active SPORT DMA chain.

1. Enter chain insertion mode by setting $SDEN_x = 0$ and $SCHEN_x = 1$ in the channel's DMA control register. The DMA interrupt indicates when the current DMA sequence is complete.
2. Copy the address currently held in the chain pointer register to the chain pointer position of the last TCB in the chain that is being inserted.
3. Write the start address of the first TCB of the new chain into the chain pointer register.
4. Resume chained DMA mode by setting $SDEN_x = 1$ and $SCHEN_x = 1$.

Setting Up and Starting Multichannel Mode

Use the $SPCTL_x$ and channel selection registers ($SPMCTL_x$) to configure the serial ports to run in multichannel mode as follows. For proper data alignment on sports in multichannel mode, the multichannel enable bit must be set last.

1. Clear all control registers ($SPCTL_{x/y}$ and $SPMCTL_{xy}$).
2. Configure the channel section registers (SP_{xCS_x} and SP_{yCS_x}).
3. For DMA mode operation, configure the DMA parameter registers (Index, Modify and Count). For DMA chaining, initialize the chain pointer register with the index register for the first chain.
4. Configure the transmitter $SPORT_x$ control register of a $SPORT_{xy}$ pair ($SPCTL_x$) and enable the DMA/DMA chaining.
5. Configure the receiver $SPORT_y$ control register of pair $SPORT_{xy}$ pair ($SPCTL_y$) and enable the DMA/DMA chaining.

Programming Model

6. In multichannel and packed I²S modes, the frame sync is independent of data. In multichannel/packed I²S mode, operation starts as soon as the MCE_x bit is enabled.

Due to the priority of other DMA channels, if the DMA controller does not load the transmit buffer with the actual value from memory, then the older value is transmitted out. Therefore, for DMA/DMA chaining mode, wait for the transmit buffer status to become non-empty by polling the DXS0_A/B bits. For core mode operation, initialize the transmit buffer with the first data word to be transmitted.

7. Configure and enable multichannel in the multichannel control registers (SPMCTL_x and SPMCTL_y).

Multichannel Mode Backward Compatibility

In previous SHARC models, the serial port pair used the same control register (SPMCTL01) to program multichannel mode. In the ADSP-21367/8/9 and ADSP-2137x processors, this register is simply renamed to SPMCTL0 and a new register, SPMCTL1 has been added. Note that both however are identical. Programs using the older code simply need to change from the SPMCTL01 register to the SPMCTL0 register or the SPMCTL1 register.

The following steps should be taken to port the code to the ADSP-21367/8/9 and ADSP-2137x products.

1. Instead of programming just SPMCTL_{xy}, program both SPMCTL_x and SPMCTL_y.
2. In previous processors the data direction bit in the SPCTL register was hard coded in multichannel mode (where the even port is always the transmitter and the odd port is always the receiver). But in the ADSP-21367/8/9 and ADSP-2137x processors, the direction (SPTRAN bit) is honored and therefore should be set as required.

3. Routing models for hard coded multichannel pairs used the even SPORT for the clock and the odd SPORT for the frame sync. The TDV signal was derived from the even frame sync. In the ADSP-21367/8/9 and ADSP-2137x processors, these limitations no longer apply. All SPORTs operate completely independently. Therefore every SPORT requires the clock and frame sync to be routed. The TDV signal is separate and is fed into the SRU unit.

Programming Packed Mode

Since packed mode is implemented on top of multichannel mode, programming this mode is the same as programming multichannel mode. Use the serial port control (SPCTLx) and channel selection registers (SPMCTLx) to configure the serial ports to run in packed mode as follows.

1. Configure the multichannel channel select registers.
2. Set the OPMODE, ICLK, IFS, CKRE bits in the SPCTLx register to run in packed master mode.
3. Clear the LSBF bit to run in packed mode.
4. To emulate I²S in packed mode, set the MFD bit field to one and the NCH bit field according to the channels in the SPMCTLx register.

The MFD bit field and the L_FIRST bit allow programs to manipulate the timing as follows.

1. The MFD bit field selects the data delay in SCLK cycles after the frame sync occurred.
2. The L_FIRST bit allows to swap the left and right channels.

Additional Information for External Frame Sync Operation

There are two procedures which allow programs to save SPORT initialization during an inactive frame sync:

- Read the `DAI_PIN_STAT` register of the frame sync to get the level prior to starting SPORT configuration.
- Route a `MISCA` register input to the external frame signal (rising or falling edge) as an interrupt trigger to generate an interrupt to start SPORT configuration.

Companding As a Function

Since the values in the transmit and receive buffers are actually companded in place, the companding hardware can be used without transmitting (or receiving) any data, for example during testing or debugging. This operation requires one peripheral clock cycle of overhead, as described below. For companding to execute properly, program the SPORT registers prior to loading data values into the SPORT buffers.

To compress data in place without transmitting use the following procedure.

1. Set the `SPTRAN` bit to 1 in the `SPCTLx` register. The `SPEN_A` and `SPEN_B` bits should be = 0.
2. Enable companding in the `DTYPE` field of the `SPCTLx` transmit control register.
3. Write a 32-bit data word to the transmit buffer. Companding is calculated in this cycle.

4. Wait two cycles. Any instruction not accessing the transmit buffer can be used to cause this delay. This allows the serial port companding hardware to reload the transmit buffer with the companded value.
5. Read the 8-bit compressed value from the transmit buffer.

To expand data in place, use the same sequence of operations with the receive buffer instead of the transmit buffer. When expanding data in this way, set the appropriate serial word length (SLEN) in the SPCTLx register.

With companding enabled, interfacing the serial port to a codec requires little additional programming effort. If companding is not selected, two formats are available for received data words of fewer than 32 bits—one that fills unused MSBs with zeros, and another that sign-extends the MSB into the unused bits.

Programming Model

8 INPUT DATA PORT

The Input Data Port (IDP) comprises two units: the serial input port (SIP) and the parallel data acquisition port (PDAP). Located inside the DAI of the SHARC processor it provides an efficient way of transferring data from DAI pin buffers, the external port, the asynchronous sample rate converters (ASRC) and the S/PDIF transceiver to the internal memory of SHARC. The IDP specifications are shown in [Table 8-1](#).

Table 8-1. IDP Port Specifications

Feature	SIP	PDAP
Connectivity		
Multiplexed Pinout	No	Yes (External Port)
SRU DAI Required	Yes	Yes
SRU DAI Default Routing	No	No
SRU2 DPI Required	No	No
SRU2 DPI Default Routing	N/A	N/A
Interrupt Control	Yes	Yes
Protocol		
Master Capable	No	No
Slave Capable	Yes	Yes
Transmission Simplex	Yes	Yes
Transmission Half Duplex	No	No
Transmission Full Duplex	No	No

Features

Table 8-1. IDP Port Specifications (Cont'd)

Feature	SIP	PDAP
Access Type		
Data Buffer	Yes	Yes
Core Data Access	Yes	Yes
DMA Data Access	Yes	Yes
DMA Channels	8	1
DMA Chaining	No	No
Boot Capable	No	No
Local Memory	No	No
Clock Operation	PCLK/4	PCLK/4

Features

The following list describes the IDP features.

- The IDP provides a mechanism for a large number of asynchronous channels (up to eight).
- Supports industry standard data formats, I²S, Left-justified and Right-justified for serial input ports.
- The PDAP supports four data packing modes for parallel data.
- The PDAP supports a maximum of 20-bits.
- Provides two data transfer types, through DMA or interrupt driven transfer by core.

Pin Descriptions

Table 8-2 provides descriptions of the IDP pins used for the serial interface port.

Table 8-2. SIP Pin Descriptions

Internal Node	I/O	Description
IDP7-0_CLK_I	I	Serial Input Port Receive Clock Input. This signal must be generated externally and comply to the supported input formats.
IDP7-0_FS_I	I	Serial Input Port Frame Sync Input. The frame sync pulse initiates shifting of serial data. This signal must be generated externally and comply to the supported input formats.
IDP7-0_DAT_I	I	Serial Input Port Data Input. Unidirectional data pin. Data signal must comply to the supported data formats.

Table 8-3 provides descriptions of the IDP pins used for the parallel interface port.

Table 8-3. PDAP Pin Descriptions

Internal Nodes	Type	Description
PDAP_CLK_I	I	Parallel Data Acquisition Port Clock Input. Positive or negative edge of the PDAP clock input is used for data latching depending on the IDP_PDAP_CLKEDGE bit (29) of the IDP_PP_CTL register. Note that input has multiplexed.
PDAP_HOLD_I	I	Parallel Data Acquisition Port Frame Sync Input. The PDAP hold signal determines whether the data is to be latched at an active clock edge or not. When the PDAP hold signal is HIGH, all latching clock edges are ignored and no new data is read from the input pins. The packing unit operates as normal, but it pauses and waits for the PDAP hold signal to be de-asserted and waits for the correct number of distinct input samples before passing the packed data to the IDP FIFO. Note that the input has multiplexed control.
PDAP_DATA	I	Parallel Data Acquisition Port Data Input. The PDAP latches 20-bit parallel data which where packed into 32-bits by using different packing. Note that input has multiplexed control.

SRU Programming

Table 8-3. PDAP Pin Descriptions (Cont'd)

Internal Nodes	Type	Description
PDAP_STRB_O	O	Parallel Data Acquisition Port Clock input. The PDAP packing unit asserts the output strobe whenever there is 32-bit data available for transfer to the IDP FIFO. The width of this pulse is equal to 2 x PCLK cycles. This signal can be used to synchronize external requests for new PDAP data. Note that input has multiplexed control.

Table 8-4 provides descriptions of the pin multiplexing between DAI and external port. For more information, see “Pin Multiplexing” on page 17-27.

Table 8-4. Pin Multiplexing between DAI and External Port

Signal	DAI	External Port
Serial Clock	IDP0_CLK_I	DATA[10]
Frame Sync	IDP0_FS_I	DATA[11]
Data	DAI_PB20-1	DATA[31-12]
Strobe Out	PDAP_STRB_O	DATA[8]

SRU Programming

The SRU (signal routing unit) needs to be programmed in order to connect the IDP to the output pins as shown in Table 8-5.

Table 8-5. IDP DAI/SRU Signal Connections

Internal Node	DAI Group	SRU Register
Inputs		
IDP7-0_CLK_I	Group A	SRU_CLK3-2

Table 8-5. IDP DAI/SRU Signal Connections (Cont'd)

Internal Node	DAI Group	SRU Register
IDP7-0_FS_I	Group C	SRU_FS3-2
IDP7-0_DAT_I	Group B	SRU_DAT5-4

Table 8-6 shows the signal connections when using the PDAP on the DAI pins.

Table 8-6. PDAP DAI/SRU Signal Connections

Internal Node	DAI Connection	SRU Register
Inputs		
IDP0_CLK_I	Group A	SRU_CLK2
PDAP_HOLD_I	Group C	SRU_FS2
DAI_PB20-1_I	Group D	SRU_PIN4-0
Outputs		
PDAP_STRB_O	Group D	

Register Overview

This section provides brief descriptions of the major registers. For complete information see [“Input Data Port Registers” on page A-95](#).

IDP Control Registers (IDP_CTLx). The ADSP-2136x and ADSP-2137x SHARC processors have two IDP control registers. The IDP_CTL1-0 registers are used to control the SIP operations.

PDAP Control Register (IDP_PP_CTL). The register (shown in [Figure 8-1](#)) is used to control all PDAP operations.

IDP Status Register (IDP_STAT). The register returns different types of status for SIP/PDAP core and DMA operations.

Clocking

The fundamental timing clock of the IDP module is peripheral clock/4 (PCLK/4). The IDP SIP/PDAP operates in slave mode only.

Functional Description

The IDP provides up to eight serial input channels—each with its own clock, frame sync, and data inputs. The eight channels are automatically multiplexed into a single 32-bit by eight-deep FIFO. Data is always formatted as a 64-bit frame and divided into two 32-bit words. The serial protocol is designed to receive audio channels in I²S, left-justified, or right-justified mode. One frame sync cycle indicates one 64-bit left-right pair, but data is sent to the FIFO as 32-bit words (that is, one-half of a frame at a time). Transfers from this FIFO to internal memory can be performed either via DMA or by interrupts driven by the core.

 IDP Channel 0 is shared by SIP0 and PDAP. All other 7 SIPs are connected to corresponding IDP channel of FIFO.

The DMA engine of the IDP implements DMA for all the 8 channels. It has eight sets of DMA parameter registers for 8 channels. Data from channel 0 is directed to internal memory location controlled by set of registers for channel 0 and so on.

The parallel data is acquired through the parallel data acquisition port (PDAP) which provides a means of moving high bandwidth data to the core's memory space. The data may be sent to memory as one 32-bit word per input clock cycle or packed together (for up to four clock cycles worth of data).

[Figure 8-1](#) provides a graphical overview of the input data port architecture. Notice that each channel is independent and contains a separate clock and frame sync input.

i The IDP provides an easy way to pump serial data into on-chip memory since it is less complex than the traditional SPORT module, limited to unidirectional slave transfers only.

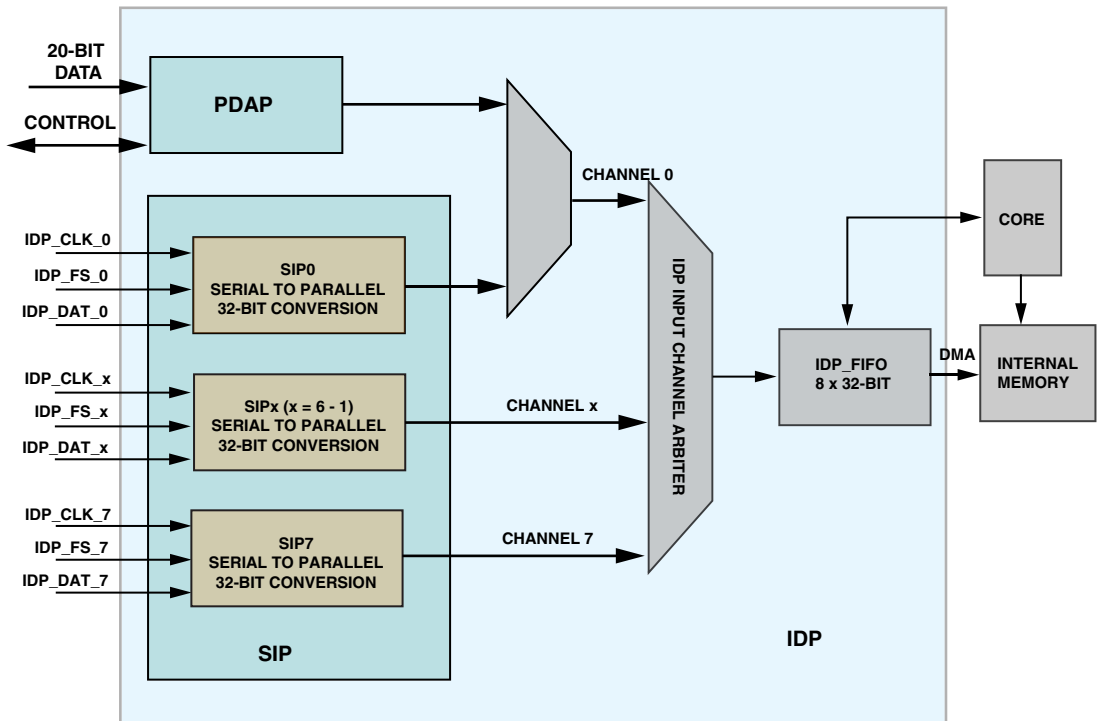

Figure 8-1. Input Data Port

Operating Modes

The following sections provide information on the various operation modes used by the PDAP module. The IDP has access to the IDP_FIFO in the three modes listed below. The bit settings that configure these modes is shown in [Table 8-7](#).

Operating Modes

- Core mode (SIP/PDAP)
- DMA mode (SIP/PDAP)
- DMA ping pong mode (SIP/PDAP)

Table 8-7. IDP Operation Modes

IDP Operation Modes	IDP_CTL0 Global Control		IDP_CTL1 Channel Control			IDP_PP_CTL	
	IDP_EN	IDP_DMA_EN	IDP_ENx	IDP_DMA_ENx	IDP_PINGx	IDP_PDAP_EN	PDAP_PP_SELECT
Core SIP7-0	1	0	1	0	0	0	0
Core PDAP DAI	1	0	1	0	0	1	0
Core PDAP EP	1	0	1	0	0	1	1
DMA SIP7-0	1	1	1	1	0	0	0
DMA PDAP DAI	1	1	1	1	0	1	0
DMA PDAP EP	1	1	1	1	0	1	1
DMA Ping Pong SIP7-0	1	1	1	1	1	0	0
DMA Ping Pong PDAP DAI	1	1	1	1	1	1	0
DMA Ping Pong PDAP EP	1	1	1	1	1	1	1

PDAP Port Selection

The input to channel 0 of the IDP is multiplexed, and may be used either in the serial mode or in a direct parallel input mode. Setting the `PDAP_EN` bit high disables the connection of `SIP0` to channel 0 of the FIFO. The data inputs can come either from the DAI pins or the external port `ADDR` pins. This is selected by the `PDAP_PP_SELECT` bit in the `PDAP_CTL` register.

Figure 8-2 illustrates the data flow for IDP channel 0, where either the PDAP or serial input can be selected.

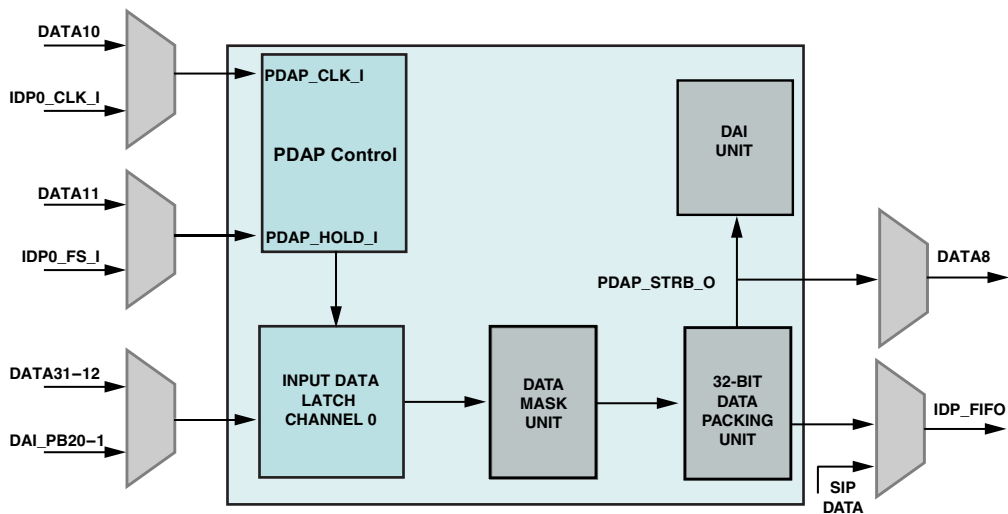

Figure 8-2. PDAP Port (Detail of IDP Channel 0)

Data Hold

When the `PDAP_HOLD` signal is high, all latching clock edges are ignored and no new data is read from the input pins. The packing unit operates as normal, but it pauses and waits for the `PDAP_HOLD` signal to be de-asserted and waits for the correct number of distinct input samples before passing the packed data to the FIFO.

Operating Modes

Figure 8-3 on page 8-11 through Figure 8-5 on page 8-13 show different packing modes including valid data hold inputs.

As shown in the figures, PDAP_DATA and PDAP_HOLD are driven by the inactive edges of the clock (falling edge in the above figures) and these signals are sampled by the active edge of the clock (rising edge in the figures).

PDAP Data Masking

For input data widths less than 20, inputs are aligned to the MSB pins. Additionally all PDAP inputs can be masked (IDP_PDAP_CTL register) to form user-specific data streams from any input pins. Clearing the MASK bits (=0) disables data from the corresponding DAI or external port pin.

PDAP Data Packing

Multiple latched parallel sub word samples may be packed into 32-bit words for efficiency. The frame sync input is used to hold off latching of the next sample (that is, ignore the clock edges). The data then flows through the FIFO and is transferred by a dedicated DMA channel into the core's memory as with any IDP channel. As shown in Figure 8-2, the PDAP can accept input words up to 20 bits wide, or can accept input words that are packed as densely as four input words up to eight bits wide.

The IDP_PDAP_PACKING bits define the packing format selection. Based on the PDAP packing the data buffer format will change as shown in Figure 8-9.

No Packing

No packing provides for 20 bits coming into the packing unit and 32 bits going out to the FIFO in a single cycle. On every clock edge, 20 bits of data are moved and placed in a 32-bit register, left-aligned. That is, bit 19 maps to bit 31. The lower bits, 11–0, are always set to zero.

This mode sends one 32-bit word to FIFO for each input clock cycle—the DMA transfer rate matches the PDAP input clock rate.

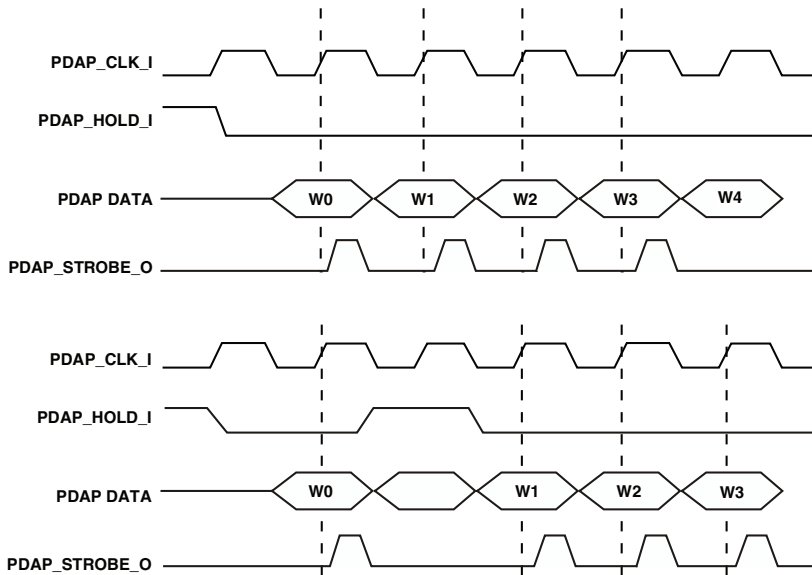

Figure 8-3. PDAP Hold Input (No Packing)

Packing by 2

Packing by 2 moves data in two cycles. Each input word can be up to 16 bits wide.

- On clock edge 1, bits 19–4 are moved to bits 15–0 (16 bits)
- On clock edge 2, bits 19–4 are moved to bits 31–16 (16 bits)

This mode sends one packed 32-bit word to FIFO for every two input clock cycles—the DMA transfer rate is one-half the PDAP input clock rate.

Operating Modes

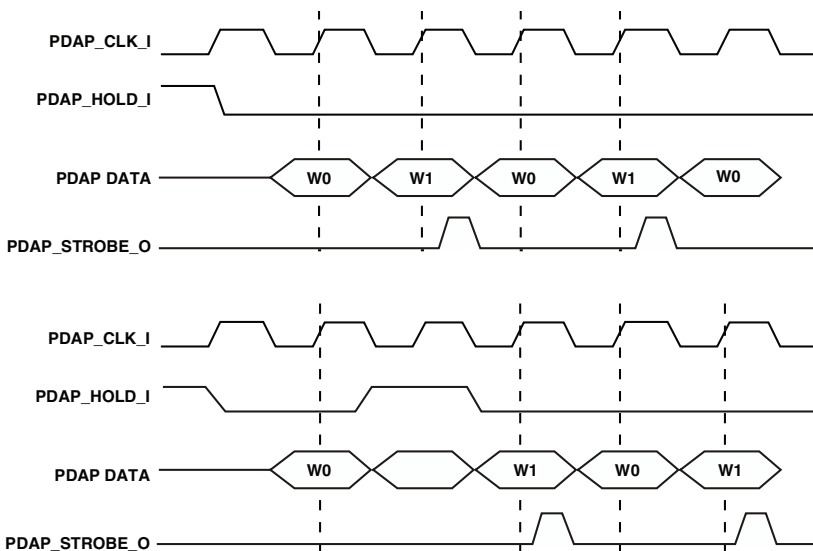

Figure 8-4. PDAP Hold Input (Packing by 2)

Packing by 3

Packing by 3 packs three acquired samples together. Since the resulting 32-bit word is not divisible by three, up to ten bits are acquired on the first clock edge and up to eleven bits are acquired on each of the second and third clock edges:

- On clock edge 1, bits 19–10 are moved to bits 9–0 (10 bits)
- On clock edge 2, bits 19–9 are moved to bits 20–10 (11 bits)
- On clock edge 3, bits 19–9 are moved to bits 31–21 (11 bits)

This mode sends one packed 32-bit word to FIFO for every three input clock cycles—the DMA transfer rate is one-third the PDAP input clock rate.

Packing by 4

Packing by 4 moves data in four cycles. Each input word can be up to eight bits wide.

- On clock edge 1, bits 19–12 are moved to bits 7–0
- On clock edge 2, bits 19–12 are moved to bits 15–8
- On clock edge 3, bits 19–12 are moved to bits 23–16
- On clock edge 4, bits 19–12 are moved to bits 31–24

This mode sends one packed 32-bit word to FIFO for every four input clock cycles—the DMA transfer rate is one-quarter the PDAP input clock rate.

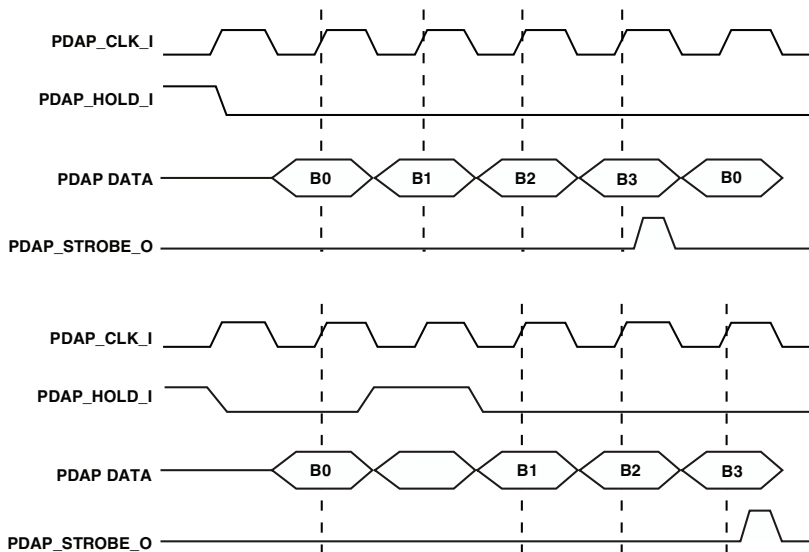

Figure 8-5. PDAP Hold Input (Packing by 4)

Data Transfer

The data from each of the eight IDP channels is inserted into an eight register deep FIFO, which can only be transferred to the core's memory space sequentially. Data is moved into the FIFO as soon as it is fully received. One of two methods can be used to move data from the IDP FIFO to internal memory:

- The core can remove data from the FIFO manually. This method of moving data from the IDP FIFO is described in the next section, “[Core Transfers](#)” on page 8-15.
- Eight dedicated DMA channels can sort and transfer data. This method of moving data from the IDP FIFO is described in “[DMA Transfers](#)” on page 8-19.

Data Buffer

The `IDP_FIFO` register provides information about the output of the 8-deep IDP FIFO which have been filled by the SIP or the PDAP units. Normally, this register is used only to read and remove the top sample from the FIFO. Channel encoding provides for eight serial input types that correspond to the `IDP_SMODEx` bits in the IDP control registers. When using channels 0–7 in serial mode, this register format applies. When using channel 0 in parallel mode, refer to the description of the packing bits for PDAP mode.



The information in [Table 8-8](#) is not valid when data comes from the PDAP channel.

Table 8-8. IDP_FIFO Register Bit Descriptions

Bit	Name	Description
2–0	CHAN_ENC	IDP Channel Encoding. These bits indicate the serial input port channel number that provided this serial input data. Note: This information is not valid when data comes from the PDAP.
3	LR_STAT	Left/Right Channel Status. Indicates whether the data in bits 31–4 is the left or the right audio channel as dictated by the frame sync signal. The polarity of the encoding depends on the serial mode selected in IDP_SMODE for that channel. See Table A-33 on page A-96 .
31–4	SDATA	Input Data (Serial). Some LSBs can be zero, depending on the mode.

Core Transfers

The core transfers require that the serial peripheral at the SIP writes data to the IDP_DATAx_I pin (DATA or DAI pins for PDAP) according to the selected input format used. These data are automatically moved to the IDP_FIFO register without DMA intervention.

The output of the FIFO can be directly fetched by reading from the IDP_FIFO buffer. The IDP_FIFO buffer is used only to read and remove the top sample from the FIFO, which is a maximum of eight locations deep. When this register is read, the corresponding element is removed from the IDP FIFO, and the next element is moved into the IDP_FIFO register. A mechanism is provided to generate an interrupt when more than a specified number of words are in the FIFO. This interrupt signals the core to read the IDP_FIFO register.

The number of data samples in the FIFO at any time is reflected in the IDP_FIFOSZ bit field (bits 31–28 in the DAI_STAT0 register), which tracks the number of samples in FIFO.

Data Transfer

The three LSBs of FIFO data are the encoded channel number. These are transferred “as is” for this mode. These bits can be used by software to decode the source of data.

i The maximum data transfer width to internal memory is 32-bits, as in the case of PDAP data or I²S and left-justified modes in single channel mode using 32 bits of data. Therefore, PDAP or I²S and left-justified 32-bit modes cannot be used with other channels in the core/interrupt driven mode since no channel information is available in the data stream.

SIP Data Buffer Format

An audio signal that is normally 24 bits wide is contained within the 32-bit word. Four bits are available for status and formatting data (compliant with the IEC 90958, S/PDIF, and AES3 standards). An additional bit identifies the left-right one-half of the frame. If the data is not in IEC standard format, the serial data can be any data word up to 28 bits wide. Unlike DMA, the core requires a status information about which channel triggered the interrupt. It does this by reading the data buffer. The remaining three bits are used to encode one of the eight channels being passed through the FIFO to the core. The FIFO output may feed eight DMA channels, where the appropriate DMA channel (corresponding to the channel number) is selected automatically.

i Regardless of mode, the L/R channel status bit (Bit 3) always specifies whether the data is received in the left channel or the right channel of the corresponding input frame, as shown in [Figure 8-6](#).

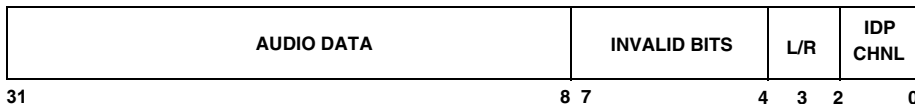

Figure 8-6. Principle Data Format for the SIP

Note that each input channel has its own clock and frame sync input, so unused IDP channels do not produce data and therefore have no impact on FIFO throughput. The clock and frame sync of any unused input should be routed by the SRU to low to avoid unintentional acquisition.

The framing format is selected by using the `IDP_SMODEx` bits (three bits per channel) in the `IDP_CTL0` register. Bits 31–8 of the `IDP_CTL0` register control the input format modes for each of the eight channels. The eight groups of three bits indicate the mode of the serial input for each of the eight IDP channels.

Figure 8-7 and Figure 8-8 shows the IDP data buffer input format for the SIP (depending on `SMODEx` bits) for core access.

RIGHT-JUSTIFIED FORMAT, 24-BIT DATA WIDTH

24 BITS AUDIO DATA	4 BITS, SET TO ZERO	L/R BIT	3 BITS IDP CHANNEL
--------------------	---------------------------	------------	--------------------------

RIGHT-JUSTIFIED FORMAT, 20-BIT DATA WIDTH

20 BITS AUDIO DATA	8 BITS, SET TO ZERO	L/R BIT	3 BITS IDP CHANNEL
--------------------	---------------------------	------------	--------------------------

RIGHT-JUSTIFIED FORMAT, 18-BIT DATA WIDTH

18 BITS AUDIO DATA	10 BITS, SET TO ZERO	L/R BIT	3 BITS IDP CHANNEL
--------------------	----------------------------	------------	--------------------------

RIGHT-JUSTIFIED FORMAT, 16-BIT DATA WIDTH

16 BITS AUDIO DATA	12 BITS, SET TO ZERO	L/R BIT	3 BITS IDP CHANNEL
--------------------	----------------------------	------------	--------------------------

Figure 8-7. IDP Data Buffer Format SIP – Right-Justified

Data Transfer

I²S AND LEFT-JUSTIFIED FORMAT

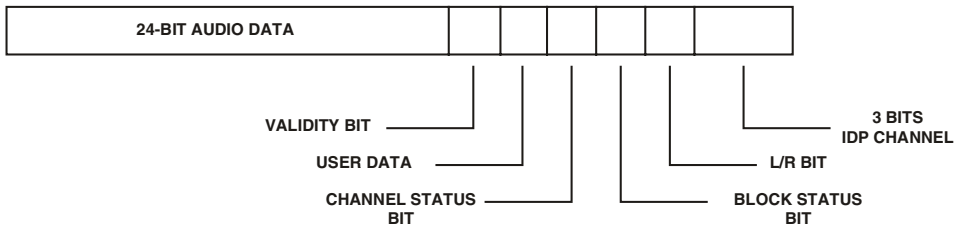

I²S AND LEFT-JUSTIFIED FORMAT, 32-BIT DATA WIDTH



Figure 8-8. IDP Data Buffer Format SIP – I²S/Left-Justified (32 Bits)

The polarity of left-right encoding is independent of the serial mode frame sync polarity selected in `IDP_SMODE` for that channel ([Table 8-3 on page 8-3](#)). Note that I²S mode uses a LOW frame sync (left-right) signal to dictate the first (left) channel, and left-justified mode uses a HIGH frame sync (left-right) signal to dictate the first (left) channel of each frame. In either mode, the left channel has bit 3 set (= 1) and the right channel has bit 3 cleared (= 0).

PDAP Data Buffer Format

If the PDAP module is enabled the IDP data buffer format will change according to the PDAP packing bits (`IDP_PDAP_CTL` register) as shown in [Figure 8-9](#).

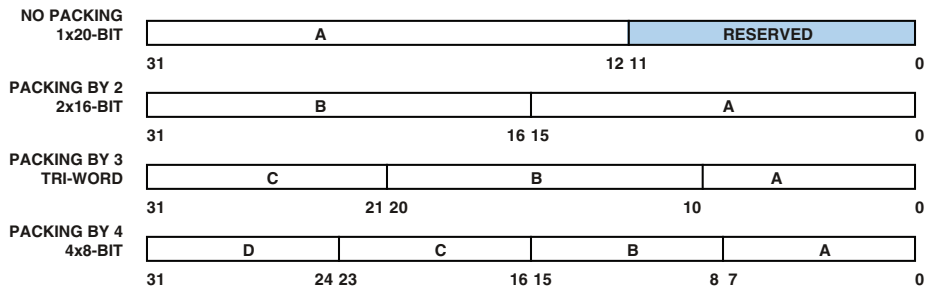

Figure 8-9. IDP Data Buffer Formats for the PDAP

DMA Transfers

The ADSP-2136x and ADSP-2137x supports two types of DMA transfers, standard and ping-pong.

Eight dedicated DMA channels can sort and transfer the data into one buffer per source channel. When the memory buffer is full, the DMA channel raises an interrupt in the DAI interrupt controller.

Data Buffer Format for DMA

The LSB bits 2–0 of the data format from the serial inputs are channel encoding bits. Since the data is placed into a separate buffer for each DMA channel (defined by parameter index registers), these bits are not required and are cleared (=0) when transferring data to internal memory through the DMA. However, bit 3 still contains the left/right status information. In the case of PDAP data or 32-bit I²S and left-justified modes, these three bits are a part of the 32-bit data.

For serial input channels, data is received in an alternating fashion from left and right channels. Data is not pushed into the FIFO as a full left/right frame. Rather, data is transferred as alternating left/right words as it is received. For the PDAP and 32-bit (non-audio) serial input, data is transferred as packed 32-bit words.

Data Transfer

DMA Channel Priority

When more than one channel has data ready, the channels always access the `IDP_FIFO` register with fixed priority, from low to high channel number (that is, channel 0 is the highest priority and channel 7 is the lowest priority). For the I/O processor, the eight DMA channels are considered as a group and arbitration can rotate across groups for system balance. [For more information, see “Operating Modes” on page 2-25.](#)

Standard DMA

The eight DMA channels each have a set of registers for standard DMA: an I-register, an M-register and a C-register are used.

The IDP DMA parameter registers have these functions:

- **Internal index registers** (`IDP_DMA_Ix`). Index registers provide an internal memory address, acting as a pointer to the next internal memory location where data is to be written.
- **Internal modify registers** (`IDP_DMA_Mx`). Modify registers provide the signed increment by which the DMA controller post-modifies the corresponding internal memory Index register after each DMA write.
- **Count registers** (`IDP_DMA_Cx`). Count registers indicate the number of words remaining to be transferred to internal memory on the corresponding DMA channel.

This DMA access is enabled when the `IDP_EN` bit and `IDP_DMA_EN` bit and the `IDP_DMA_ENx` bits register are set to select a particular channel. The DMA is performed according to the parameters set in the various DMA registers and IDP control registers. An interrupt is generated after end of DMA transfer (when the count = 0).

Ping-Pong DMA

In ping-pong DMA, the parameters have two memory index values (index A and index B), one count value and one modifier value. The DMA starts the transfer with the memory indexed by A. When the transfer is completed as per the value in the count register, the DMA restarts with the memory location indexed by B. The DMA restarts with index A after the transfer to memory with index B is completed as per the count value.

The IDP DMA parameter registers have these functions:

- **Internal index registers** (`IDP_DMA_IxA`, `IDP_DMA_IxB`). Index A/B registers provide an internal memory address, acting as a pointer to the next internal memory location where data is to be written.
- **Internal modify registers** (`IDP_DMA_Mx`). Modify registers provide the signed increment by which the DMA controller post-modifies the corresponding internal memory Index register after each DMA write.
- **Ping-Pong Count registers** (`IDP_DMA_PCx`). Count registers indicate the number of words remaining to be transferred to internal memory on the corresponding DMA channel.

This mode is activated when the `IDP_EN` bit, the `IDP_DMA_EN` bit, the `IDP_DMA_ENx` bits, and the `IDP_PINGx` bits are set for a particular channel. An interrupt is generated after every ping and pong DMA transfer (when the count = 0).

 Note that ping-pong DMA is repeated until stopped by resetting the `IDP_DMA_ENx` bits (OR global `IDP_DMA_EN` bit).

Multichannel DMA Operation

The SIP/PDAP can run both standard and ping-pong DMAs in different channels. When running standard DMA, initialize the corresponding `IDP_DMA_Ix`, `IDP_DMA_Mx` and `IDP_DMA_Cx` registers. When running

Data Transfer

ping-pong DMA, initialize the corresponding `IDP_DMA_IxA`, `IDP_DMA_IxB`, `IDP_DMA_Mx` and `IDP_DMA_PCx` registers.

DMA transfers for all 8 channels can be interrupted by changing the `IDP_DMA_EN` bit in the `IDP_CTL0` register. None of the other control settings (except for the `IDP_EN` bit) should be changed. Clearing the `IDP_DMA_EN` bit (= 0) does not affect the data in the FIFO, it only stops DMA transfers. If the IDP remains enabled, an interrupted DMA can be resumed by setting the `IDP_DMA_EN` bit again. But resetting the `IDP_EN` bit flushes the data in the FIFO. If the bit is set again, the FIFO starts accepting new data.

Programs can drop DMA requests from the FIFO if needed. If one channel has finished its DMA, and the global `IDP_DMA_EN` bit is still set (=1), any data corresponding to that channel is ignored by the DMA machine. This feature is provided to avoid stalling the DMA of other channels, which are still in an active DMA state. To avoid data loss in the finished channel, programs can clear (=0) `IDP_DMA_EN` bit as discussed in previously.

Multichannel FIFO Status

The state of all eight DMA channels is reflected in the `IDP_DMAX_STAT` bits (bits 24–17 of `DAI_STAT` register). These bits are set once the `IDP_DMA_EN` and `IDP_DMA_ENx` bits are set, and remain set until the last data from that channel is transferred. Even if the `IDP_DMA_EN` and `IDP_DMA_ENx` bits remain set, the `IDP_DMAX_STAT` bits clear once the required number of data transfers takes place.

 Note that when a DMA channel is not used (that is, parameter registers are at their default values), the DMA channel's corresponding `IDP_DMAX_STAT` bit is cleared (= 0).

If the combined data rate from the channels is more than the DMA can service, a FIFO overflow occurs. This condition is reflected for each channel by the individual overflow bits (`SRU_OVFX`) in the `DAI_STAT0` register.

These are sticky bits that must be cleared by writing to the `IDP_CLR0VR` bit (bit 6 of the `IDP_CTL0` register). When an overflow occurs, incoming data from IDP channels is not accepted into the FIFO, and data values are lost. New data is only accepted once space is again created in the FIFO.

Interrupts

This section describes the different types of interrupts used by the interface. [Table 8-9](#) provides an overview of IDP interrupts.

Table 8-9. IDP Interrupt Overview

Interrupt Sources	Interrupt Condition	Interrupt Completion	Interrupt Acknowledge	Default IVT
DAI IDP (I2S, left/right justified, TDM, 8 channels)	<ul style="list-style-type: none"> – DMA RX done – Core RX buffer size exceeded – RX buffer overflow error 	Internal transfer completion	Read-to-clear <code>DAI_IRPTL_x</code> + RTI instruction	P0I, P12I

Interrupt Acknowledge

The correct handling of the IDP interrupt requires that the ISR must read the `DAI_IRPTL_x` register to clear the interrupt latch appropriately. Note that many interrupts are combined in the DAI interrupt. Refer to [“Interrupts” on page 6-32](#).

Threshold Interrupts

When using the interrupt scheme shown in [Table 8-9](#), the `IDP_NSET` bits (bits 3-0 of the `IDP_CTL0` register) can be set to N , so $N + 1$ data can be read from the FIFO in the interrupt service routine (ISR). The `IDP_FIFO_GTN_INT` bit in the `DAI_IRPTL_X` register allows flexible interrupts in order to respond with the core under different system conditions.

Interrupts

DMA Interrupts

Using DMA transfers overrides the mechanism used for interrupt-driven core reads from the FIFO. When the `IDP_DMA_EN` bit and at least one `IDP_DMA_ENx` of the `IDP_CTL1` register are set, the eighth interrupt (`IDP_FIFO_GTN_INT`) in the `DAI_IRPTL_x` registers is NOT generated.

At the end of the DMA transfer for individual channels, interrupts are generated. These interrupts are generated after the last DMA data from a particular channel has been transferred to memory. These interrupts (`IDP_DMAx_INT`) are mapped from bits 17–10 in the `DAI_IMASK_x` registers and generate interrupts when they are set (= 1). These bits are ORed and reflected in high level interrupts that are sent to the DAI interrupt.

An interrupt is generated at the end of a DMA, which is cleared by reading the `DAI_IRPTL_x` registers.

FIFO Overflow Interrupts

If the data out of the FIFO (either through DMA or core reads) is not sufficient to transfer at the combined data rate of all the channels, then a FIFO overflow can occur. When this happens, new data is not accepted. Additionally, data coming from the serial input channels (except for 32-bit I²S and left-justified modes) are not accepted in pairs, so that alternate data from a channel is always from left and right channels. If overflow occurs, an interrupt is generated if the `IDP_FIFO_OVR_INT` bit in the `DAI_IMASK_x` register is set (sticky bits in `DAI_STAT0` register are also set). Data is accepted again when space has been created in the FIFO.

Note that the total FIFO depth per channel is 9 locations: 1 location for SIP to parallel data conversion + 8 locations for the `IDP_FIFO` register.

Debug Features

The following sections describe the features available for debugging the IDP.

Status Register Debug

The core may also write to the FIFO. When it does, the audio data word is pushed into the input side of the FIFO (as if it had come from the SRU on the channel encoded in the three LSBs). This can be useful for verifying the operation of the FIFO, the DMA channels, and the status portions of the IDP. The `IDP_STAT1` register returns the current state of the read/write index pointers from FIFO.

Buffer Hang Disable

The `IDP_BHD` bit in the `IDP_CTL0` register is used for buffer hang disable control. When there is no data in the FIFO, reading the `IDP_FIFO` register causes the core to hang. This condition continues until the FIFO contains valid data. Setting the `IDP_BHD` bit (= 1) prevents the core from hanging on reads from an empty `IDP_FIFO` register. Clearing this bit (= 0) causes the core to hang under the conditions described previously.

If the `IDP_BHD` bit (bit 4 in the `IDP_CTL0` register) is not set, attempts to read more data than is available in the FIFO results in a core hang.

Shadow Registers

The DAI interrupt controller contains shadow registers to simplify debug techniques since these register are not updated. A read of the `DAI_IMASK_x_SH` register provides the same data as a read of the `DAI_IMASK_x` register. Reading these DAI shadow registers (`DAI_IMASK_x_SH`) does not destroy the contents of the `DAI_IRPTL_x` registers.

Effect Latency

Core FIFO Write

The core may also write to the FIFO. When it does, the audio data word is pushed into the input side of the FIFO (as if it had come from the SRU on the channel encoded in the three LSBs). This can be useful for verifying the operation of the FIFO, the DMA channels, and the status portions of the IDP. The `IDP_STAT1` register returns the current state of the read/write index pointers from FIFO.

Effect Latency

The total effect latency is a combination of the write effect latency (core access) plus the peripheral effect latency (peripheral specific).

Write Effect Latency

For details on write effect latency, see *SHARC Processor Programming Reference*.

IDP Effect Latency

The IDP is ready to start receiving data one serial clock cycle (`SCLK`) after it is enabled by setting `IDP_EN` bit. No `LRCLK` edges are lost from this point on.

Disabling IDP DMA by resetting the `IDP_DMA_EN` bit requires 1 `PCLK` cycle. Disabling an individual DMA channel by resetting the `IDP_DMA_ENx` bit requires 2 `PCLK` cycles.

Programming Model

The following sections provide procedures that are helpful when programming the input data port.

Setting Miscellaneous Bits

This sequence is used in most of the following programming models as an intermediate step.

Set the required values for:

- `IDP_SMODEx` bits in the `IDP_CTLx` register to specify the frame sync format for the serial inputs (left-justified I²S, or right-justified mode).
- `IDP_Pxx_PDAPMASK` bits in the `IDP_PP_CTL` register to specify the input mask, if the PDAP is used.
- `IDP_PP_SELECT` bits in the `IDP_PP_CTL` register to specify input from the DAI pins or the DATA pins, if the PDAP is used.
- `IDP_PDAP_CLKEDGE` bit (bit 29) in the `IDP_PP_CTL` register to specify if data is latched on the rising or falling clock edge, if the PDAP is used.

Starting Core Interrupt-Driven Transfer

To start a core interrupt-driven data transfer:

1. Clear the FIFO by setting (= 1) `IDP_FFCLR` bit (bit 31 in the `IDP_CTL1` register).
2. Keep the `SCLK` and frame sync inputs of the SIP and PDAP connected to low, by setting the proper values in the SRU registers.
3. Refer to “[Setting Miscellaneous Bits](#)” above.

Programming Model

4. Program the SRU registers to establish the proper connection to the SIP and/or PDAP being used. Keep the unused clock and frame sync signals connected to low.
5. Set the desired values for the N_SET variable using the `IDP_NSET` bits in the `IDP_CTLO` register.
6. Set the `IDP_FIFO_GTN_INT` bit (bit 8 of the `DAI_IMASK_RE` register) to HIGH and set the corresponding bit in the `DAI_IMASK_FE` register to LOW to unmask the interrupt. Set bit 8 of the `DAI_IMASK_PRI` register (`IDP_FIFO_GTN_INT`) as needed to generate a high priority or low priority core interrupt when the number of words in the FIFO is greater than the value of N set.
7. Enable the PDAP by setting `IDP_PDAP_EN` (bit 31 in the `IDP_PP_CTL` register), if required.
8. Enable the IDP by setting the `IDP_EN` bit (bit 7 in the `IDP_CTLO` register) and the `IDP_ENx` bits in the `IDP_CTL1` register.



In older SHARC processors, the IDP starts shifting data before the IDP is enabled. However, the shifted data is latched at the next frame sync edge only if the IDP is enabled. Therefore, whether the first channel received by the IDP is left/right depends on the instant when the IDP is enabled—which may lead to channel swapping.

Additional Notes

When IDPs are used to receive data from external devices, there is a sequence to be followed to enable the IDP ports when configured to receive data in I²S mode. Failing to follow this sequence can cause channel shift or swap.

1. Connect the frame sync internally using the SRU (signal routing unit) to the DAI interrupt.
2. Configure the DAI interrupt (`MISCA` register) for the inactive edge of the frame sync.
3. Wait for the DAI interrupt, and enable the IDP port inside the DAI interrupt service routine.
4. Clear the DAI interrupt by reading the DAI interrupt latch register. This procedure ensures that the IDP ports are enabled at the correct time, avoiding issues like channel shift or swap in the received data.

Starting A Standard DMA Transfer

To start a DMA transfer from the FIFO to memory:

1. Clear the FIFO by setting (= 1) the `IDP_FFCLR` bit (bit 31 in the `IDP_CTL1` register).
2. While the global `IDP_DMA_EN` and the `IDP_EN` bits are cleared (= 0), set the values for the DMA parameter registers that correspond to channels 7–0.
3. Keep the clock and the frame sync input of the serial inputs and/or the PDAP connected to low, by setting proper values in the SRU registers.
4. Refer to [“Setting Miscellaneous Bits” on page 8-27](#).
5. Route all of the required inputs to the IDP by writing to the SRU registers

Programming Model

6. Enable the channel's `IDP_ENx` and `IDP_DMA_ENx` bit settings.
7. Start the DMA by setting:
 - The `IDP_PDAP_EN` bit (bit 31 in the `IDP_PP_CTL` register if the PDAP is required).
 - The global `IDP_DMA_EN` bit of the `IDP_CTL0` register to enable standard DMA on the selected channel.
 - The global `IDP_EN` bit (bit 7 in the `IDP_CTL0` register).

Starting a Ping-Pong DMA Transfer

To start a ping-pong DMA transfer from the FIFO to memory:

1. Clear the FIFO by setting (= 1) the `IDP_FFCLR` bit (bit 31 in the `IDP_CTL1` register).
2. While the global `IDP_DMA_EN` and `IDP_EN` bits are cleared (=0), set the values for the following DMA parameter registers that correspond to channels 7–0.
3. Keep the clock and the frame sync input of the serial inputs and/or the PDAP connected to LOW, by setting proper values in the SRU registers.
4. Refer to [“Setting Miscellaneous Bits”](#) above.
5. Connect all of the required inputs to the IDP by writing to the SRU registers.

6. Enable the channel's `IDP_ENx`, `IDP_DMA_ENx` and `IDP_PINGx` bit settings.
7. Start DMA by setting:
 - The `IDP_PDAP_EN` bit (bit 31 in `IDP_PP_CTL` register if the PDAP is required).
 - The global `IDP_DMA_EN` bit of the `IDP_CTL0` register to enable the standard DMA of the selected channel.
 - The global `IDP_EN` bit (bit 7 in the `IDP_CTL0` register).

Servicing Interrupts for DMA

The following steps describe how to handle an IDP ISR for DMA.

1. An interrupt is generated and program control jumps to the ISR when the DMA for a channel completes.
2. The program clears the `IDP_DMA_EN` bit in the `IDP_CTL` register.
 - a. To ensure that the DMA of a particular IDP channel is complete, (all data is transferred into internal memory) wait until the `IDP_DMAx_STAT` bit of that channel becomes zero in the `DAI_STAT` register. This is required if a high priority DMA (for example a SPORT DMA) is occurring at the same time as the IDP DMA.
 - b. As each DMA channel completes, a corresponding bit in either the `DAI_IMASK_L` or `DAI_IMASK_H` register for each DMA channel is set (`IDP_DMAx_INT`).
3. The program clears (= 0) the channel's `IDP_DMA_ENx` bit in the `IDP_CTL1` register which has finished.
4. Reprogram the DMA registers for finished DMA channels.

Programming Model

More than one DMA channel may have completed during this time period. For each, a bit is latched in the `DAI_IMASK_L` or `DAI_IMASK_H` registers. Ensure that the DMA registers are reprogrammed. If any of the channels are not used, then its clock and frame sync should be held low.

5. Read the `DAI_IMASK_L` or `DAI_IMASK_H` registers to see if more interrupts have been generated.
 - If the value(s) are not zero, repeat step 4.
 - If the value(s) are zero, continue to step 6.
6. Re-enable the `IDP_DMA_EN` bit in the `IDP_CTL` register (set to 1).
7. Exit the ISR.

If a zero is read in step 5 (no more interrupts are latched), then all of the interrupts needed for that ISR have been serviced. If another DMA completes after step 5 (that is, during steps 6 or 7), as soon as the ISR completes, the ISR is called again because the OR of the latched bits will not be non zero again. DMAs in process run to completion.

 If step 5 is not performed, and a DMA channel expires during step 4, then, when IDP DMA is re-enabled, (step 6) the completed DMA is *not* reprogrammed and its buffer overruns.

This unit is multiplexed with SIP0. The PDAP provides one clock input, one clock hold input and a maximum of 20 parallel data input pins. The positive or negative edge of the clock input is used for data latching. The clock hold input (`PDAP_HLD_I`) validates a clock edge—if this input is high then clock edge is masked for data latching. It supports four types of data packing mode selected by `MODE` bits in the `PDAP_CTL` register.

9 ASYNCHRONOUS SAMPLE RATE CONVERTER

The asynchronous sample rate converter (SRC) block is used to perform synchronous or asynchronous sample rate conversion across independent stereo channels, without using any internal processor resources. Furthermore, the SRC is used to clean up audio data from jittery clock sources such as the S/PDIF receiver. The SRC specifications are listed in [Table 9-1](#).

Table 9-1. SRC Specifications

Feature	Availability
Connectivity	
Multiplexed Pinout	No
SRU DAI Required	Yes
SRU DAI Default Routing	No
SRU2 DPI Required	No
SRU2 DPI Default Routing	N/A
Interrupt Control	Yes
Protocol	
Master Capable	No
Slave Capable	Yes
Transmission Simplex	Yes
Transmission Half Duplex	No
Transmission Full Duplex	No

Features

Table 9-1. SRC Specifications (Cont'd)

Feature	Availability
Access Type	
Data Buffer	No
Core Data Access	N/A
DMA Data Access	N/A
DMA Channels	N/A
DMA Chaining	N/A
Boot Capable	N/A
Local Memory	Yes (RAM, ROM)
Clock Operation	PCLK/4

Features

The SRC for the SHARC processors has the features shown in the list below.

- 4 sample rates converters
- Automatically senses sample frequencies
- Simple programming required
- Attenuates sample clock jitter
- Supports left-justified, I²S, right-justified (16-, 18-, 20-, 24-bits), and TDM serial port (daisy chain) modes independent between input and output port.
- Accepts 16-/18-/20-/24-bit data
- Up to 192 kHz sample rate input/output sample ratios from 7.75:1 to 1:8

- Linear phase FIR filter
- Controllable soft mute

Pin Descriptions

The SRC has two interfaces: an input port and an output port. [Table 9-2](#) describes the six inputs and two outputs for the IP (input port) and OP (output port).

Table 9-2. SRC Pin Descriptions

Internal Node	I/O	Description
SRC3-0_CLK_IP_I	Input	SRC input port clock input
SRC3-0_FS_IP_I	Input	SRC input port frame sync input
SRC3-0_DAT_IP_I	Input	SRC input port data input
SRC3-0_CLK_OP_I	Input	SRC output port clock input
SRC3-0_FS_OP_I	Input	SRC output port frame sync input
SRC3-0_TDM_OP_I	Input	SRC output port TDM daisy chain data input
SRC3-0_DAT_OP_O	Output	SRC output port data output
SRC3-0_TDM_IP_O	Output	SRC output port TDM daisy chain data output

SRU Programming

The SRU (signal routing unit) needs to be programmed in order to connect the SRCs to the output pins or any other peripherals. For normal operation, the data, clock, and frame sync signals need to be routed as shown in [Table 9-3](#).

Register Overview

Table 9-3. SRC DAI/SRU Signal Routing

Internal Node	DAI Connection	SRU Register
Inputs		
SRC3-0_CLK_IP_I SRC3-0_CLK_OP_I	Group A	SRU_CLK2-1
SRC3-0_FS_IP_I SRC3-0_FS_OP_I	Group C	SRU_FS2-1
SRC3-0_DAT_IP_I SRC3-0_TDM_OP_I	Group B	SRU_DAT3-2
Outputs		
SRC3-0_DAT_OP_O	Group B, D	
SRC3-0_TDM_IP_O	Group B	

For information on using the SRU, see [“Rules for SRU Connections”](#) on page 6-20.

Register Overview

This section provides brief descriptions of the major registers. For complete information see [“Sample Rate Converter Registers”](#) on page A-104.

Control Registers (SRCCTLx). Enable or disable the sample rate converters. They also specify the input and output data format.

Mute Register (SRCMUTE). Controls the connection of the mute in and mute out signal.

Ratio Registers (SRCRATx). Return the sample ratio between the input and out data stream and mute information (mute out).

Clocking

The fundamental timing clock of the ASRC module is peripheral clock/4 ($PCLK/4$) and is operating in slave mode only.

The number of SRCs that can be daisy-chained together is limited by the maximum frequency of $SRCx_CLK_xx_I$, which is about $PCLK/4$. For example, if the output sample rate, f_S , is 96 kHz, up to eight SRCs could be connected since $512 f_S$ is less than 50 MHz (where $PCLK = 200$ MHz).

Functional Description

Figure 9-1 shows a top level block diagram of the SRC module and Figure 9-2 on page 9-7 shows architecture details. The sample rate converter's FIFO block adjusts the left and right input samples and stores them for the FIR filter's convolution cycle. The $SRCx_FS_IP$ counter provides the write address to the FIFO block and the ramp input to the digital-servo loop. The ROM stores the coefficients for the FIR filter convolution and performs a high-order interpolation between the stored coefficients. The sample rate ratio block measures the sample rate by dynamically altering the ROM coefficients and scaling the FIR filter length and input data. The digital-servo loop automatically tracks the $SRCx_FS_IP$ and $SRCx_FS_OP$ sample rates and provides the RAM and ROM start addresses for the start of the FIR filter convolution.



Unlike other peripherals, the sample rate converters own local memories (RAM and ROM) which are dedicated for the purpose of sample rate conversion only.

Functional Description

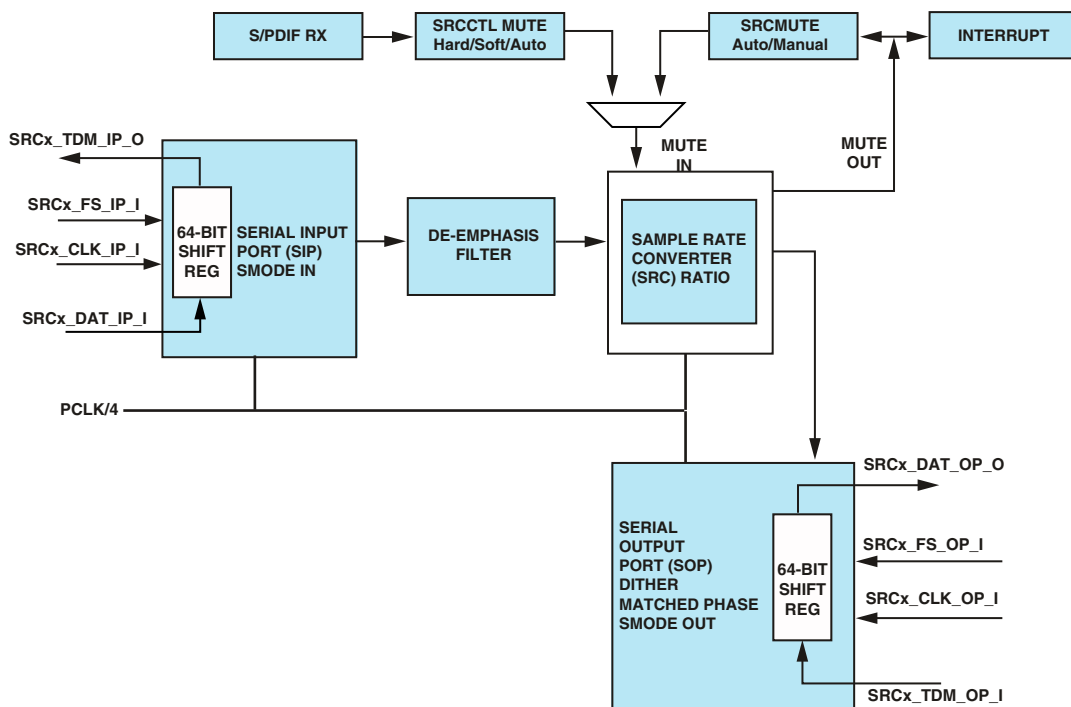

Figure 9-1. Sample Rate Converter Block Diagram

The FIFO receives the left and right input data and adjusts the amplitude of the data for both the soft muting of the SRC and the scaling of the input data by the sample rate ratio before storing the samples in RAM. The input data is scaled by the sample rate ratio because as the FIR filter length of the convolution increases, so does the amplitude of the convolution output. To keep the output of the FIR filter from saturating, the input data is scaled down by multiplying it by $(SRCx_FS_OP)/(SRCx_FS_IP)$ when $SRCx_FS_OP < SRCx_FS_IP$. The FIFO also scales the input data to mute and stop muting the SRC.

The RAM in the FIFO is 512 words deep for both left and right channels. An offset of 64 to the write address, provided by the `SRCx_FS_IP` counter, is added to prevent the RAM read pointer from overlapping the write

Asynchronous Sample Rate Converter

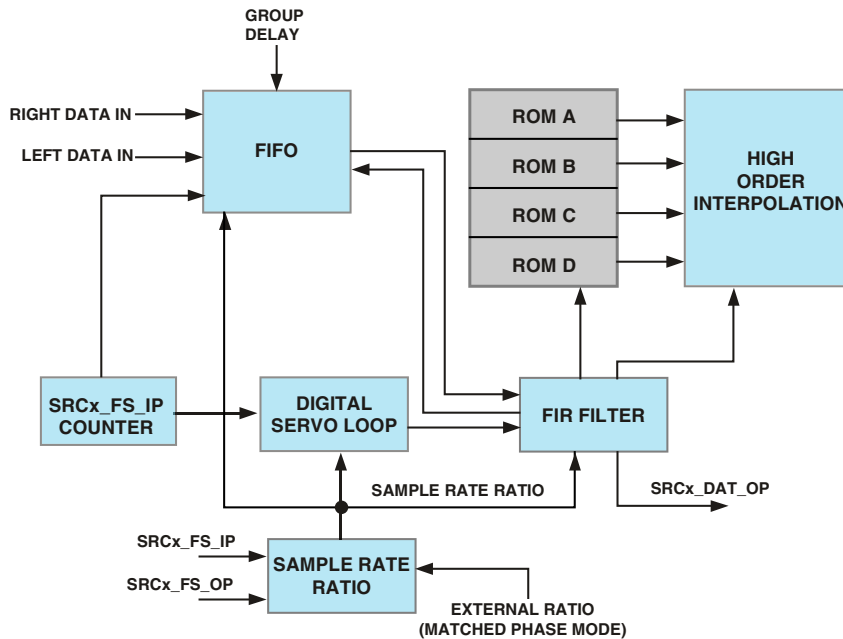

Figure 9-2. Sample Rate Converter Architecture

address. This offset value is useful for applications when small changes in the sample rate ratio between `SRCx_FS_IP` and `SRCx_FS_OP` are expected. The maximum decimation rate can be calculated from the RAM word depth is $(512 - 64) \div 64 \text{ taps} = 7$.

The digital-servo loop is essentially a ramp filter that provides the initial pointer to the address in RAM and ROM for the start of the FIR convolution. The RAM pointer is the integer output of the ramp filter while the ROM pointer is the fractional part. The digital-servo loop must be able to provide excellent rejection of jitter on the `SRCx_FS_IP` and `SRCx_FS_OP` clocks as well as measure the arrival of the `SRCx_FS_OP` clock within 4.97 ps. The digital-servo loop also divides the fractional part of the ramp output by the ratio of $(\text{SRCx_FS_IP})/(\text{SRCx_FS_OP})$ for the case when $\text{SRCx_FS_IP} > \text{SRCx_FS_OP}$, to dynamically alter the ROM coefficients.

Functional Description

The digital-servo loop is implemented with a multi-rate filter. To settle the digital-servo loop filter quickly at startup or at a change in the sample rate, a fast mode has been added to the filter. When the digital-servo loop starts up or the sample rate is changed, the digital-servo loop kicks into fast mode to adjust and settle on the new sample rate. Upon sensing the digital-servo loop settling down to some reasonable value, the digital-servo loop kicks into normal or slow mode. During fast mode, the `SRCx-_MUTE_OUT` bit of the SRC is asserted to remind the user to mute the SRC which avoids clicks and pops.

The FIR filter is a 64-tap filter in the case of $SRCx_FS_OP < SRCx_FS_IP$ and is $(SRCx_FS_IP)/(SRCx_FS_OP) \times 64$ taps for the case when $SRCx_FS_IP > SRCx_FS_OP$. The FIR filter performs its convolution by loading in the starting address of the RAM address pointer and the ROM address pointer from the digital-servo loop at the start of the `SRCx_FS_OP` period. The FIR filter then steps through the RAM by decrementing its address by 1 for each tap, and the ROM pointer increments its address by the $(SRCx_FS_OP/SRCx_FS_IP) \times 2^{20}$ ratio for $SRCx_FS_IP > SRCx_FS_OP$ or 2^{20} for $SRCx_FS_OP < SRCx_FS_IP$. Once the ROM address rolls over, the convolution is complete. The convolution is performed for both the left and right channels, and the multiply/accumulate circuit used for the convolution is shared between the channels.

The $(SRCx_FS_IP)/(SRCx_FS_OP)$ sample rate ratio circuit is used to dynamically alter the coefficients in the ROM for the case when $SRCx_FS_IP > SRCx_FS_OP$. The ratio is calculated by comparing the output of an `SRCx_FS_OP` counter to the output of an `SRCx_FS_IP` counter. If $SRCx_FS_OP > SRCx_FS_IP$, the ratio is held at one. If $SRCx_FS_IP > SRCx_FS_OP$, the sample rate ratio is updated if it is different by more than two `SRCx_FS_OP` periods from the previous `SRCx_FS_OP` to `SRCx_FS_IP` comparison. This is done to provide some hysteresis to prevent the filter length from oscillating and causing distortion.

However, the hysteresis of the $(SRCx_FS_OP)/(SRCx_FS_IP)$ ratio circuit can cause phase mismatching between two SRCs operating with the same

input and output clocks. Since the hysteresis requires a difference of more than two `SRCx_FS_OP` periods to update the `SRCx_FS_OP` and `SRCx_FS_IP` ratios, two SRCs may have differences in their ratios from 0 to 4 `SRCx_FS_OP` period counts. The $(\text{SRCx_FS_OP})/(\text{SRCx_FS_IP})$ ratio adjusts the filter length of the SRC, which corresponds directly with the group delay. Thus, the magnitude in the phase difference depends upon the resolution of the `SRCx_FS_OP` and `SRCx_FS_IP` counters. The greater the resolution of the counters, the smaller the phase difference error.

Operating Modes

The SRC can operate in TDM, I²S, left-justified, right-justified, matched phase, and bypass modes. The serial ports of the processor can be used for moving the SRC data to/from the internal memory.

In I²S, left-justified and right-justified modes, the SRCs operate individually. The serial data provided in the input port is converted to the sample rate of the output port. [Figure 9-3](#) shows the timing in the various formats.

Operating Modes

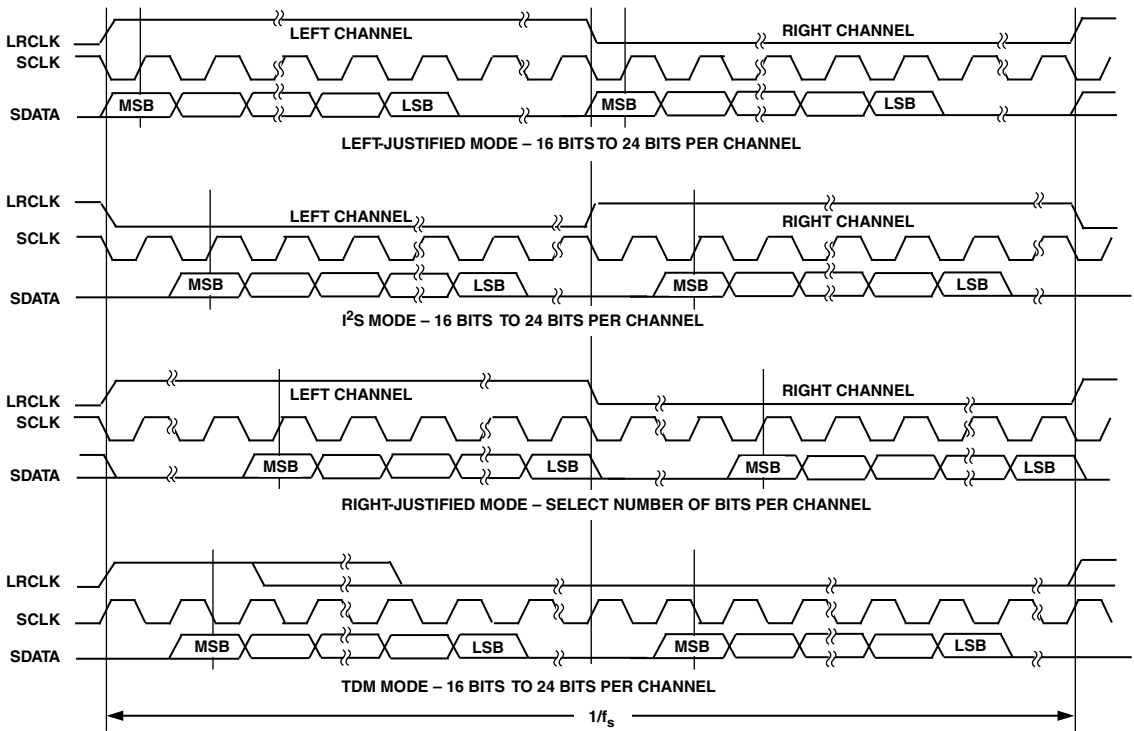

NOTES

- ¹ LRCLK NORMALLY OPERATES AT ASSOCIATIVE INPUT OR OUTPUT SAMPLE FREQUENCY (f_s).
- ² SCLK FREQUENCY IS NORMALLY $64 \times$ LRCLK EXCEPT FOR TDM MODE WHICH IS $N \times 64 \times f_s$, WHERE N = NUMBER OF STEREO CHANNELS IN THE TDM CHAIN.
- ³ PLEASE NOTE THAT 8 BITS OF EACH 32-BIT SUBFRAME ARE USED FOR TRANSMITTING MATCHED-PHASE MODE DATA.

Figure 9-3. SRC Data Format

TDM Daisy Chain Mode

The SRCs are daisy chained together to achieve the TDM mode of operation.

TDM Input Daisy Chain

In TDM input port, several SRCs can be daisy-chained together and connected to the serial input port of a SHARC processor or other processor (Figure 9-4). The SRC IP contains a 64-bit parallel load shift register. When the $SRCx_FS_IP_I$ pulse arrives, each SRC parallel loads its left and right data into the 64-bit shift register. The input to the shift register is connected to $SRCx_DAT_IP_I$, while the output is connected to $SRCx_TDM_IP_O$. By connecting the $SRCx_TDM_IP_O$ to the $SRCx_DAT_IP_I$ of the next SRC, a large shift register is created, which is clocked by $SRCx_IP_CLK_I$.

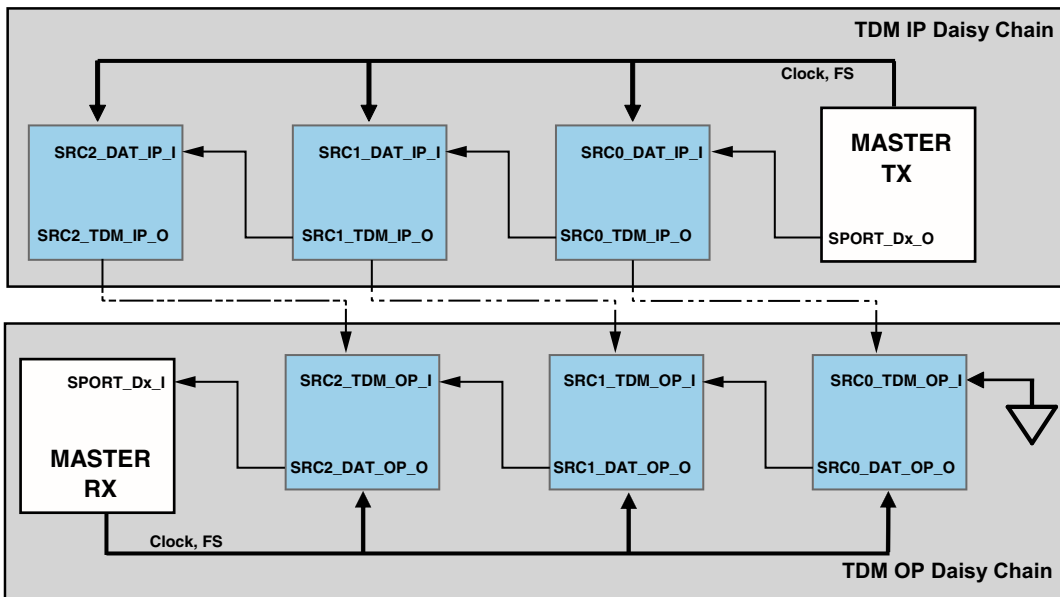

Figure 9-4. TDM Input/Output Modes

Operating Modes

TDM Output Daisy Chain

In TDM output port, several SRCs can be daisy-chained together and connected to the SPORT of an ADSP-2136x or other processor (Figure 9-4). The SRC OP contains a 64-bit parallel load shift register. When the SRCx_FS_OP_I pulse arrives, each SRC loads its left and right data into the 64-bit shift register. The input to the shift register is connected to SRCx_DAT_OP_0, and the output is connected to SRCx_TDM_OP_I. By connecting the SRCx_TDM_IP_0 to the SRCx_DAT_IP_I of the next SRC, a large shift register is created, which is clocked by SRCx_CLK_OP_I.

Bypass Mode

When the BYPASS bit is set (=1), the input data bypasses the sample rate converter and is sent directly to the serial output port. Dithering of the output data when the word length is set to less than 24 bits is disabled. This mode is ideal when the input and output sample rates are the same and SRCx_FS_IP_I and SRCx_FS_OP_I are synchronous with respect to each other. This mode can also be used for passing through non-audio data since no processing is performed on the input data in this mode.

Matched-Phase Mode

The matched phase mode of the sample rate converter is enabled by the SRCx_MPHASE bit. This mode is used to match the phase (group delay) between two or more adjacent sample rate converters that are operating with the same input and output clocks. When the SRCx_MPHASE bit is set (=1), the SRC, a matched phase mode slave accepts the sample rate ratio transmitted by another SRC, the matched phase mode master, through its serial output as shown in Figure 9-5.

Asynchronous Sample Rate Converter

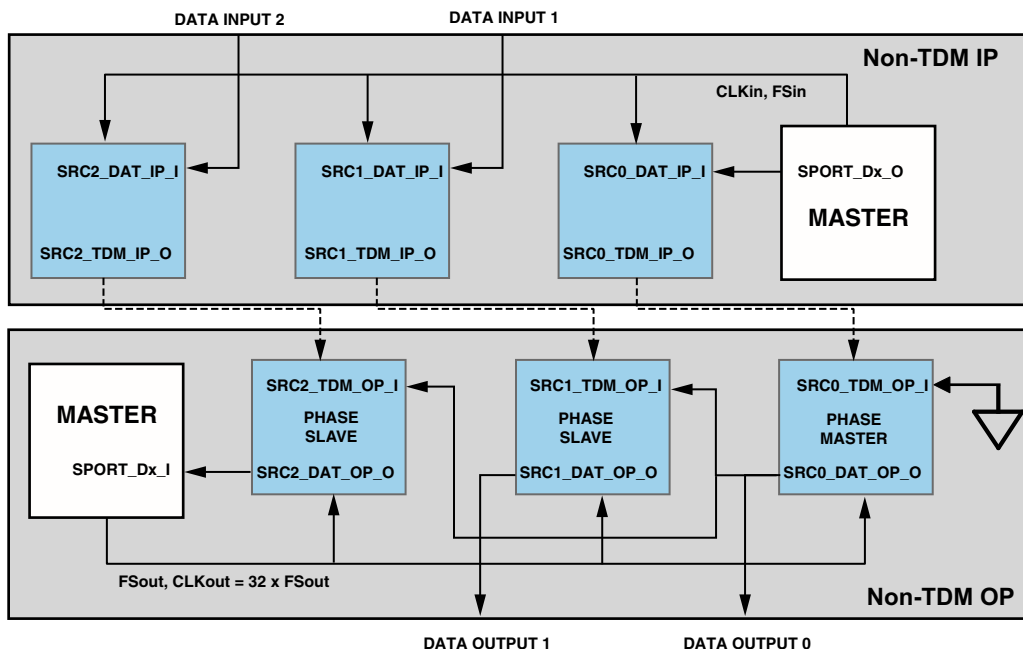

Figure 9-5. Typical Configuration for Matched-Phase Mode Operation

The phase master SRC device transmits its $SRCx_FS_OP/SRCx_FS_IP$ ratio through the data output pin ($SRCx_DAT_OP_0$) to the slave's SRC's data input pins ($SRCx_TDM_OP_I$). The transmitted data (32-bit subframe) contains 24-bit data and 8-bits matched phase. The slave SRCs receive the 8-bit matched phase bits (instead of their own internally-derived ratio) if their $SRCx_MPHASE$ bits set to 1, respectively.

The $SRCx_FS_IP$ and $SRCx_FS_OP$ signals may be asynchronous with respect to each other in this mode. Note there must be 32 $SRCx_CLK_OP$ cycles per subframe in matched-phase mode (24-bits data and 8-bits phase match).

Operating Modes

Data Format Matched-Phase Mode

The SRC supports the matched-phase mode for all serial output data formats; left-justified, I²S, right-justified, and TDM mode. Note that in the left-justified, I²S, and TDM modes, the lower 8 bits of each channel sub-frame are used to transmit the matched-phase data. In right-justified mode, the upper eight bits are used to transmit the matched-phase data. This is shown in [Figure 9-6](#).

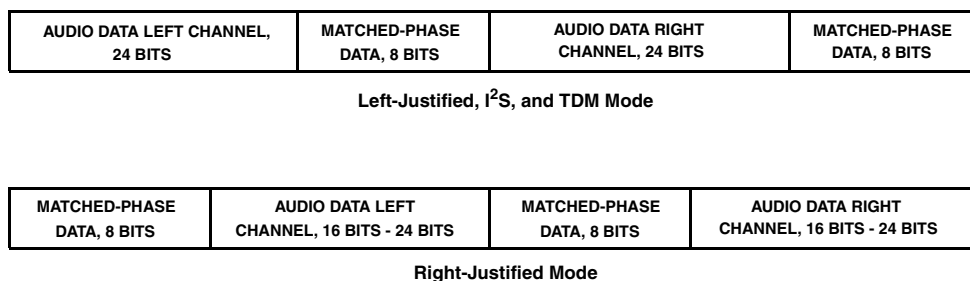

Figure 9-6. Matched-Phase Data Transmission

Group Delay

When multiple SRCs are used with the same serial input port clock and the same serial output port clock, the hysteresis causes different group delays (phase mismatches) between multiple SRCs. The filter group delay of the SRC is given by the equations:

$$GDS = \frac{16}{SRCx_FS_IP} + \frac{32}{SRCx_FS_IP} \text{seconds for } (SRCx_FS_OP \geq SRCx_FS_IP)$$

$$GDS = \frac{16}{SRCx_FS_IP} + \left(\frac{32}{SRCx_FS_IP} \right) \times \left(\frac{SRCx_FS_IP}{SRCx_FS_OP} \right) \text{seconds for } (SRCx_FS_OP \leq SRCx_FS_IP)$$

Decimation Rate

The RAM in the FIFO is 512 words deep for both left and right channels. An offset to the write address provided by the f_{S_IN} counter is added to prevent the RAM read pointer from ever overlapping the write address. The offset is fixed by the group delay signal. A small offset, 16, is added to the write address pointer.

Increasing the offset of the write address pointer is useful for applications when small changes in the sample rate ratio between f_{S_IN} and f_{S_OUT} are expected. The maximum decimation rate can be calculated from the RAM word depth and GRPDLYS as $(512 - 16)/64$ taps = 7.75:1.

Muting Modes

The mute feature of the SRC can be controlled automatically in hardware using the MUTE_IN signal by connecting it to the MUTE_OUT signal. Automatic muting can be disabled by setting (=1) the SRCx_MUTE_EN bits in the SRCMUTE register.



Note that by default, the SRCMUTE register connects the MUTE_IN signal to the MUTE_OUT signal, but not vice versa.

Soft Mute

When the SRCx_SOFTMUTE bit in the SRCCTL register is set, the MUTE_IN signal is asserted, and the SRC performs a soft mute by linearly decreasing the input data to the SRC FIFO to zero, (–144 dB) attenuation as described for automatic hardware muting.

A 12-bit counter, clocked by SRCx_FS_IP_I, is used to control the mute attenuation. Therefore, the time it takes from the assertion of MUTE_IN to –144 dB, full mute attenuation is 4096 FS cycles.

Likewise, the time it takes to reach 0 dB mute attenuation from the de-assertion of MUTE_IN is 4096 FS cycles.

Interrupts

Hard Mute

When the `SRCx_HARD_MUTE` bit in the `SRCCTL` register is set, the SRC immediately mutes the input data to the SRC FIFO to zero, (−144 dB) attenuation.

Auto Mute

When the `SRCx_AUTO_MUTE` bit in the `SRCCTLx` register is set, the SRC communicates with the S/PDIF receiver peripheral to determine when the input should mute. Each SRC is connected to the S/PDIF receiver to read the `DIR_NOAUDIO` bits. When the `DIR_NOAUDIO` bit is set (=1), the SRC immediately mutes the input data to the SRC FIFO to zero, (−144 dB) attenuation.

This mode is useful for automatic detection of non-PCM audio data received from the S/PDIF receiver.

Interrupts

The SRC mute-out signal can be used to generate interrupts on their rising edge, falling edge, or both, depending on how the DAI interrupt mask registers (`DAI_IMASK_RE/FE`) are programmed. This allows the generation of `DAIHI/DAILI` interrupts either entering mute, exiting muting or both.

The `SRCx_MUTE_OUT` interrupt is generated only once when the SRC is locked (after 4096 FS input samples) and after changes to the sample ratio. Hard mute, soft mute, and auto mute only control the muting of the input data to the SRC.

Asynchronous Sample Rate Converter

Table 9-4 provides an overview of SRC interrupts.

Table 9-4. SRC Interrupt Overview

Interrupt Source	Interrupt Condition	Interrupt Completion	Interrupt Acknowledge	Default IVT
DAI SRC RX/TX (I2S, left/right justified, TDM, 4 channels)	– Mute out asserted (SRC init, SRC sample rate change)		Read-to-clear DAI_IRPTL_x + RTI instruction	P0I, P12I

Debug Features

The asynchronous sample rate converter allow the bypass mode. When the `BYPASS` bit is set (=1), the input data bypasses the sample rate converter and is sent directly to the serial output port. This mode can be used for testing both ports when the input and output sample rates are at the same frequency, therefore both input and output ports can be routed to the same serial clock and frame sync.

Effect Latency

The total effect latency is a combination of the write effect latency (core access) plus the peripheral effect latency (peripheral specific).

Write Effect Latency

For details on write effect latency, see *SHARC Processor Programming Reference*.

Effect Latency

SRC Effect Latency

After the ASRC registers are configured the effect latency is 1.5 PCLK cycles minimum and 3 PCLK cycles maximum.

10 SONY/PHILIPS DIGITAL INTERFACE

The Sony/Philips Digital Interface (S/PDIF) is a standard audio data transfer format that allows the transfer of digital audio signals from one device to another without having to convert them to an analog signal. The digital audio interface carries three types of information; *audio data*, *non audio data (compressed data)* and *timing information*. Its specifications are listed in [Table 10-1](#).

Table 10-1. S/PDIF Specifications

Feature	Transmitter	Receiver
Connectivity		
Multiplexed Pinout	No	No
SRU DAI Required	Yes	Yes
SRU DAI Default Routing	No	No
SRU2 DPI Required	No	No
SRU2 DPI Default Routing	N/A	N/A
Interrupt Control	Yes	Yes
Protocol		
Master Capable	No	Yes
Slave Capable	Yes	No
Transmission Simplex	Yes	Yes
Transmission Half Duplex	No	No
Transmission Full Duplex	No	No

Features

Table 10-1. S/PDIF Specifications (Cont'd)

Feature	Transmitter	Receiver
Access Type		
Data Buffer	No	No
Core Data Access	N/A	N/A
DMA Data Access	N/A	N/A
DMA Channels	N/A	N/A
DMA Chaining	N/A	N/A
Boot Capable	N/A	N/A
Local Memory	No	No
Clock Operation	PCLK/4	PCLK/4

Features

The S/PDIF interface has the following features.

- AES3-compliant S/PDIF transmitter and receiver.
- Transmitting a biphasic mark encoded signal that may contain any number of audio channels (compressed or linear PCM) or non-audio data.
- S/PDIF receiver managing clock recovery with separate S/PDIF PLL or optional using external PLL circuit.
- S/PDIF receiver direct supports DTS frames of 256, 512 and 1024
- Managing user status information and providing error-handling capabilities in both the transmitter and receiver.
- DAI allows interactions over DAI by serial ports, IDP and/or the external DAI pins to interface to other S/PDIF devices. This includes using the receiver to decode incoming biphasic encoded

audio streams and passing them via the SPORTs to internal memory for processing-or using the transmitter to encode audio or digital data and transfer it to another S/PDIF receiver in the audio system.



It is important to be familiar with serial digital audio interface standards IEC-60958, EIAJ CP-340, AES3 and AES11.

Pin Descriptions

Table 10-2 provides descriptions of the pins used for the S/PDIF transmitter.

Table 10-2. S/PDIF Transmitter Pin Descriptions

Internal Node	I/O	Description
DIT_CLK_I	Input	Serial clock. Controls the rate at which serial data enters the S/PDIF module. This is typically 64 time slots. ¹
DIT_DAT_I	Input	Serial Data. The format of the serial data can be I ² S, and right- or left-justified.
DIT_FS_I	Input	Serial Frame Sync.
DIT_HFCLK_I	Input	Input sampling clock. The over sampling clock (which is divided down according to the FREQMULT bit in the transmitter control register to generate the biphase clock)
DIT_EXTSYNC_I	Input	External Synchronization. Used for synchronizing the internal frame counter with an external frame sync signal. External synchronisation is enabled with bit 15 (DITCTL register).

Pin Descriptions

Table 10-2. S/PDIF Transmitter Pin Descriptions (Cont'd)

Internal Node	I/O	Description
DIT_O	Output	Transmit Biphase Mark Encoded Data Stream.
DIT_BLKSTART_O	Output	Transmit Block Start. Indicates the last frame of the current block. This is high for the entire duration of the last frame. This can also be connected to the DAI interrupts 31–22 using SRU_MISCx registers.

- 1 Timing for the S/PDIF format consists of time slots, unit intervals, subframes, and frames. For a complete explanation of S/PDIF timing, see one of the digital audio interface standards listed in the “Features” section of this chapter.

Table 10-3 provides descriptions of the pins used for the S/PDIF receiver.

Table 10-3. S/PDIF Receiver Pin Descriptions

Internal Node	I/O	Description
SPDIF_EXTPLLCLK_I	Input	PLL clock input ($512 \times FS$). Input clock for external PLL.
DIR_I	Input	Biphase mark encoded data receiver input stream.
DIR_CLK_O	Output	Extracted receiver sample clock output.
DIR_TDMCLK_O	Output	Receiver TDM clock out. This clock is $256 \times DIR_FS_O$
DIR_FS_O	Output	Extracted receiver frame sync out.
DIR_DAT_O	Output	Extracted audio data output.
DIR_LRCLK_FB_O	Output	Receiver frame sync feed back output. Input for external PLL.
DIR_LRCLK_REF_O	Output	Receiver frame sync reference clock output. Input for external PLL.

SRU Programming

The SRU (signal routing unit) is used to connect the S/PDIF transmitter biphase data out to the output pins or to the S/PDIF receiver. The serial clock, frame sync, data, and EXT_SYNC (if external synchronization is required) inputs also need to be routed through SRU (see [Table 10-4](#) and [Table 10-5](#)).

The SRU (signal routing unit) needs to be programmed in order to connect the S/PDIF receiver to the output pins or any other peripherals and also for the connection to the input biphase stream.

Table 10-4. S/PDIF DAI/SRU Transmitter Signal Connections

Internal Node	DAI Group	SRU Register
Inputs		
DIT_CLK_I DIT_HFCLK_I DIT_EXTSYNC_I	Group A	SRU_CLK4-2
DIT_DAT_I	Group B	SRU_DAT4
DIT_FS_I	Group C	SRU_FS2
Outputs		
DIT_O	Group B, D	
DIT_BLKSTART_O	Group D, E	

Program the corresponding SRU registers to connect the outputs to the required destinations ([Table 10-5](#)). The biphase encoded data and the external PLL clock inputs to the receiver are routed through the signal routing unit (SRU). The extracted clock, frame sync, and data are also routed through the SRU.

Register Overview

Table 10-5. S/PDIF DAI/SRU Receiver Signal Connections

Internal Node	DAI Group	SRU Register
Inputs		
SPDIF_EXTPLLCLK_I	Group A	SRU_CLK4
DIR_I	Group C	SRU_DAT5
Outputs		
DIR_CLK_O DIR_TDMCLK_O	Group A, D	
DIR_FS_O	Group C, D	
DIR_DAT_O	Group B, D	
DIR_LRCLK_FB_O DIR_LRCLK_REF_O	Group D	

Register Overview

This section provides brief descriptions of the major registers. For complete information see [“Sony/Philips Digital Interface Registers” on page A-119](#).

Transmit Control Register (DITCTL). Contains control parameters for the S/PDIF transmitter. The control parameters include transmitter enable, mute information, over sampling clock division ratio, SCDF mode select and enable, serial data input format select and validity and channel status buffer selects.

Transmit Channel Status Registers (DITCHANAx/Bx). Provide status bit information for transmitter subframe A and B in standalone mode.

Transmit User Bit Registers (DITUSRBITAx/Bx). Provide user bit information for transmitter subframe A and B in standalone mode.

Receive Control Register (DIRCTL). Contains control parameters for the S/PDIF receiver. The control parameters include mute information, error controls, SCDF mode select and enable, and S/PDIF PLL disable.

Receive Status Register (DIRSTAT). The receiver also detects errors in the S/PDIF stream. These error bits are stored in the status register, which can be read by the core. Optionally, an interrupt may be generated to notify the core on error conditions.

Receive Channel Status Registers (DIRCHANAx/Bx). Provide status information for receiver subframe A and B.

Clocking

The fundamental timing clock of the S/PDIF is peripheral clock/4 ($PCLK/4$).

S/PDIF Transmitter

The following sections provide information on the S/PDIF transmitter.

Functional Description

The S/PDIF transmitter, shown in [Figure 10-1](#) resides within the DAI, and its inputs and outputs can be routed via the SRU. It receives audio data in serial format, encloses the specified user status information, and converts it into the biphase encoded signal. The serial data input to the transmitter can be formatted as left-justified, I²S, or right-justified with word widths of 16, 18, 20 or 24 bits. [Figure 10-2 on page 10-9](#) shows detail of the AES block.

S/PDIF Transmitter

The serial data, clock, and frame sync inputs to the S/PDIF transmitter are routed through the signal routing unit (SRU). For more information, see “DAI Signal Routing Unit Registers” on page A-40.

The S/PDIF transmitter output may be routed to an output pin via the SRU and then routed to another S/PDIF receiver or to components for off-board connections to other S/PDIF receivers. The output is also available to the S/PDIF receiver for loop-back testing through SRU.

In addition to encoding the audio data in the bi-phase format, the transmitter also provides a way to easily add the channel status information to the outgoing bi-phase stream. There are status/user registers for a frame (192-bits/24 bytes) in the transmitter that correspond to each channel or subframe.

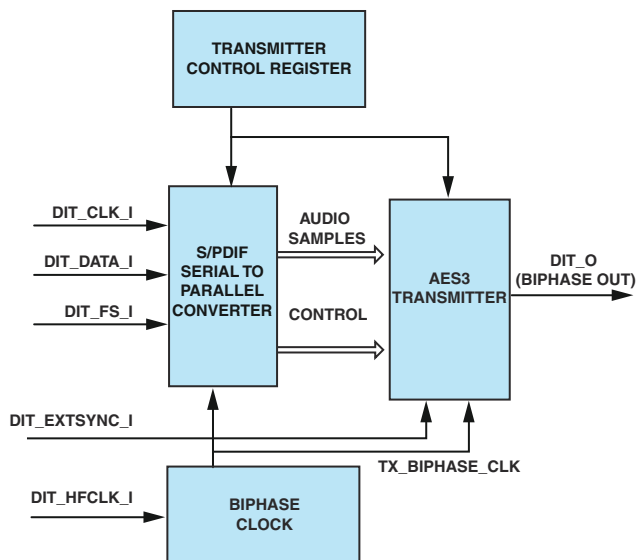

Figure 10-1. S/PDIF Transmitter Block Diagram

Validity bits for both channels may also be controlled by the transmitter control register. Optionally, the user bit, validity bit, and channel status

bit are sent to the transmitter with each left/right sample. For each sub-frame the parity bit is automatically generated and inserted into the bi-phase encoded data. A mute control and support for double-frequency single-channel mode are also provided. The serial data input format may be selected as left-justified, I²S, or right-justified with 16-, 18-, 20- or 24-bit word widths. The over sampling clock is also selected by the transmitter control register.

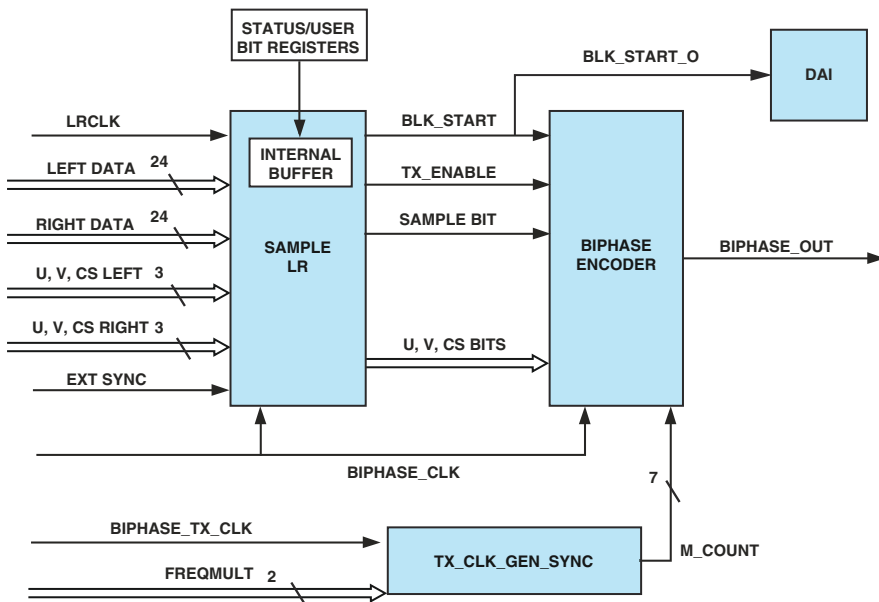

Figure 10-2. AES3 Transmit Output Block

S/PDIF Transmitter

Input Data Format

The [Figure 10-3](#) and [Figure 10-4](#) shows the format of data that is sent to the S/PDIF transmitter using a variety of interfaces.

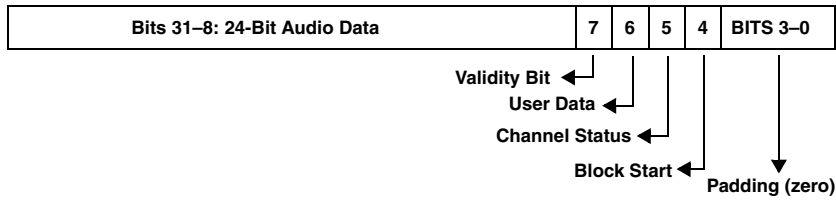
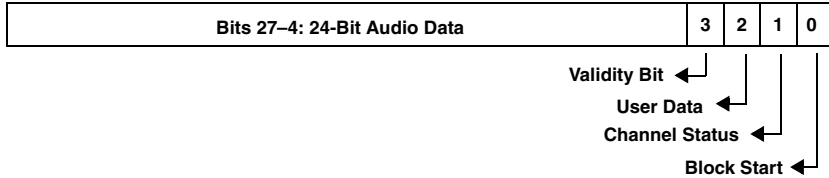

Figure 10-3. Data Packing for I²S, Left-Justified and Receiver Output Format



When I²S format is used with 20-bit or 16-bit data, the audio data should be placed from the MSB of the 24-bit audio data.

Data Packing for Right-Justified Format, 24 Bits



Data Packing for Right-Justified Format, 20 Bits

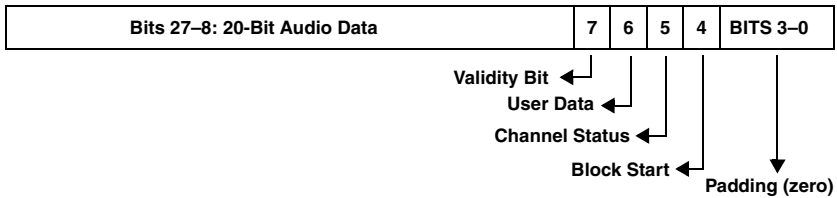

Data Packing for Right-Justified Format, 18 Bits

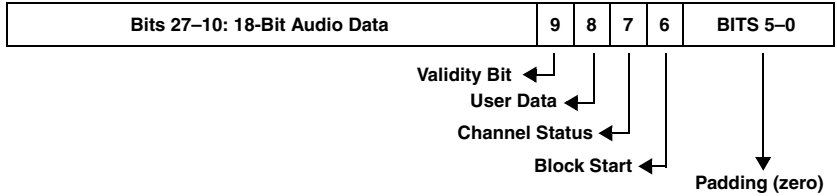

Data Packing for Right-Justified Format, 16 Bits

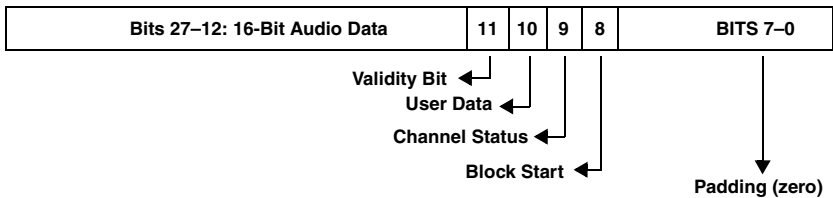

Figure 10-4. Data Packing for Right-Justified Format

Operating Modes

The S/PDIF transmitter can operate in standalone and full serial modes. The following sections describe these modes in detail.

Full Serial Mode

This mode is selected by clearing bit 9 in the `DITCTL` register. In this mode all the status bits, audio data and the block start bit (indicating start of a frame), come through the serial data stream (`DIT_DATA_I`) pin. The transmitter should be enabled after or at the same time as all of the other control bits.

Standalone Mode

This mode is selected by setting bit 9 in the `DITCTL` register. In this mode, the block start bit (indicating the start of a frame) is generated in the transmitter and not in the data stream. The channel status bits come from the channel status buffer registers (`DITCHANAx` and `DITCHANBx`). The user status bits come from the user bits buffers (`DITUSRBITAx` and `DITUSRBITBx`) as shown in [Figure 10-2 on page 10-9](#).

 The channel status buffer must be programmed before the S/PDIF transmitter is enabled and used for all the successive blocks of data.

The validity bit for channel A and B are taken from bit 10 and bit 11 of the `DITCTL` register. In this mode only audio data comes from the `DIT_DATA_I` pin. All other data, including the status bit and block start bit is either generated internally or taken from the internal register.

Once the user bits buffer registers (`DITUSRBITA0-5` and `DITUSRBITB0-5`) are programmed, they are used only for the next block of data. This allows programs to change the user bit information in every block of data.

To allow user bit updates, writes a 0x1 to the `DITUSRUPD` register that is used for further processing. If the `DIT_AUTO` bit in the `DITCTL` register is set:

- At every 192nd Frame end, if `DITUSRUPD = 1`, then the user status bits are taken from user bits buffers and transmitted. Simultaneously, the `DITUSRUPD` register is cleared automatically by hardware.
- At every 192nd Frame end, if `DITUSRUPD = 0` then the user status bits are updated as zeros and transmitted. The `DITUSRUPD` register remains low.



For the first block of transfer, write a one (1) to the `DITUSRUPD` register and then enable the S/PDIF transmitter.

In general, for the next block, programs can update user bits buffers at any time during the transfer of the current block (1 block = 192 frames).

There are internal buffers to store the user status bits of the current block of transfer. In other words, at the beginning of every new block, the user status bit (`DIT_USRPEND` in the `DITCTL` register) from user bits buffers are copied to internal buffers and transmitted in each frame during the transfer.

Note that since a frame contains $192 \text{ bits}/8 = 24$ bytes, six status/user registers are required to store each four bytes.

Data Output Mode

Two output data formats are supported by the transmitter; *two channel mode* and *single-channel double-frequency* (SCDF) mode. The output format is determined by the transmitter control register (`DITCTL`).

In two channel mode, the left channel (channel A) is transmitted when the `DIT_FS_I` is high and the right channel (channel B) is transmitted when the `DIT_FS_I` is low.

S/PDIF Receiver

In SCDF mode, the transmitter sends successive audio samples of the same signal across both sub frames, instead of channel A and B. The transmitter will transmit at half the sample rate of the input bit stream. The `DIT_SCDF` bit (bit 4 in the `DITCTL` register) selects SCDF mode. When in SCDF mode, the `DIT_SCDF_LR` bit (bit 5 in the `DITCTL` register) register decides whether left or right channel data is transmitted.

S/PDIF Receiver

The S/PDIF receiver ([Figure 10-5](#)) is compliant with all common serial digital audio interface standards including IEC-60958, IEC-61937, AES3, and AES11. These standards define a group of protocols that are commonly associated with the S/PDIF interface standard defined by AES3, which was developed and is maintained by the Audio Engineering Society. The AES3 standard effectively defines the data and status bit structure of an S/PDIF stream. AES3-compliant data is sometimes referred to as AES/EBU compliant. This term highlights the adoption of the AES3 standard by the European Broadcasting Union.

Functional Description

 The S/PDIF receiver is enabled at default to receive in two-channel mode. If the receiver is not used, programs should disable the receiver as the digital PLL may produce unwanted switching noise.

If the receiver is not used, programs should disable the digital PLL to avoid unnecessary switching. This is accomplished by writing into the `DIR_RESET` bit in the `DIRCTL` register. In most cases, when the S/PDIF receiver is used, this register does not need to be changed. After the SRU programming is complete, write to the `DIRCTL` register with control values. At this point, the receiver attempts to lock.

For a detailed description of this register, see [“Receive Control Register \(DIRCTL\)”](#) on page A-124.

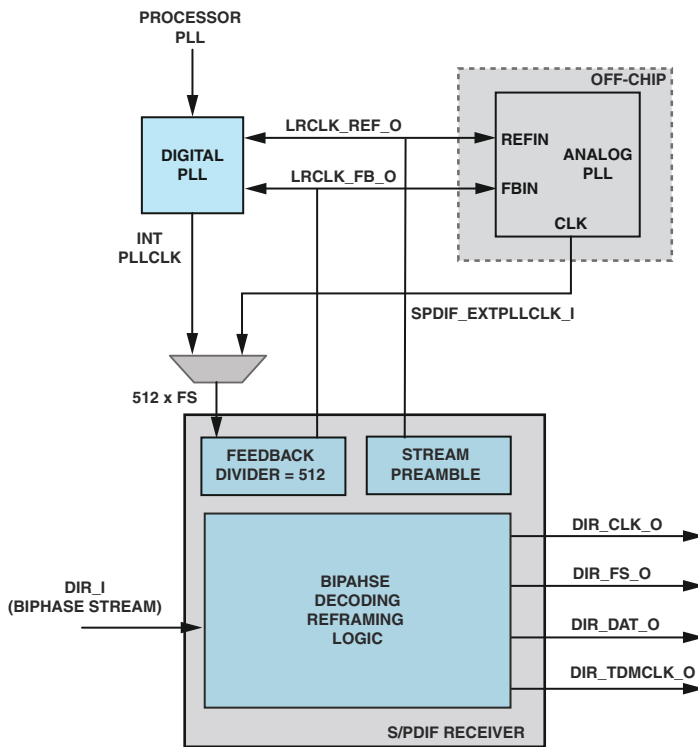

Figure 10-5. S/PDIF Receiver Block Diagram

The input to the receiver (`DIR_I`) is a biphasic encoded signal that may contain two audio channels (compressed or linear PCM) or non-audio data. The receiver decodes the single biphasic encoded stream, producing an I²S compatible serial data output that consists of a serial clock, a left-right frame sync, and data (channel A/B). It provides the programmer with several methods of managing the incoming status bit information.

The S/PDIF receiver receives any S/PDIF stream with a sampling frequency range of 32 kHz – 15% to 192 kHz + 15% range.

The channel status bits are collected into memory-mapped registers, while other channel status and user bytes must be handled manually. The block

S/PDIF Receiver

start bit, which replaces the parity bit in the serial I²S stream, indicates the reception of the Z preamble and the start of a new block of channel status and data bits.

Clock Recovery

The phased-locked loop for the AES3/SPDIF receiver is intended to recover the clock that generated the AES3/SPDIF biphasic encoded stream. This clock is used by the receiver to clock in the biphasic encoded data stream and also to provide clocks for either the SPORTs, sample rate converter, or the AES3/SPDIF transmitter. The recovered clock may also be used externally to the chip for clocking D/A and A/D converters.

In order to maintain performance, jitter on the clock is sourced to several peripherals. Jitter on the recovered clock must be less than 200 ps and, if possible, less than 100 ps across all the sampling frequencies ranging from 27.2 kHz to 220.8 kHz (32 kHz – 15% and 192 kHz + 15%). Furthermore, once the PLL achieves lock, it is able to vary $\pm 15\%$ in frequency over time. This allows for applications that do not use PLL unlocking.

To be AES11 compliant, the recovered left/right clock must be aligned with the preambles within a + or – 5% of the frame period. Since the PLL generates a clock 512 times the frame rate clock ($512 \times FS$), this clock can be used and divided down to create the phase aligned jitter-free left/right clock. For more information on recovered clocks, see [“Clock Recovery Modes” on page 10-19](#).

Output Data Format

The extracted 24-bit audio data, V, U, C and block start bits are sent on the DIR_DAT_0 pin in 32-bit I²S format as shown in [Figure 10-3 on page 10-10](#). The frame sync is transmitted on the DIR_FS_0 pin and serial clock is transmitted on the DIR_CLK_0 pin. All three pins are routed through the SRU.

Channel Status

The channel status for the first bytes 4–0 (consumer mode) are collected into memory-mapped registers (`DIRCTL` and `DIRCHANA/DIRCHANB` registers). All other channel status bytes 23–5 (professional mode) must be manually extracted from the receiver data stream.

 Only the first 5 channel status bytes (40-bit) for consumer mode of a frame are stored into the S/PDIF receiver status registers.

Operating Modes

This section describes the receiver channel status for the different modes.

Compressed or Non-linear Audio Data

The S/PDIF receiver processes compressed as well as non-linear audio data according to the supported standards. The following sections describe how this peripheral handles different data.

The AES3/SPDIF receiver is required to detect compressed or non-linear audio data according to the AES3, IEC60958, and IEC61937 standards. Bit 1 of byte 0 in the `DIRSTAT` register indicates whether the audio data is linear PCM, (bit 1=0), or non-PCM audio, (bit 1=1). If the channel status indicates non-PCM audio, the `DIR_NOAUDIO` bit flag is set. (This bit can be used to generate an interrupt.) The `DIR_VALID` bit (bit 3 in the `DIRSTAT` register) when set (=1) may indicate non-linear audio data as well. Whenever this bit is set, the `DIR_VALID` bit flag is set in the `DIRSTAT` register.

MPEG-2, AC-3, DTS, and AAC compressed data may be transmitted without setting either the `DIR_VALID` bit or bit 1 of byte 0. To detect this data, the IEC61937 and SMPTE 337M standards dictate that there be a 96-bit sync code in the 16-, 20- or 24-bit audio data stream. This sync code consists of four words of zeros followed by a word consisting of 0xF872 and another word consisting of 0x4E1F. When this sync code is

S/PDIF Receiver

detected, the `DIR_NOAUDIO` bit flag is set. If the sync code is not detected again within 4096 frames, the `DIR_NOAUDIO` bit flag is deasserted.

The last two words of the sync code, `0xF872` and `0x4E1F`, are called the preamble-A and preamble-B of the burst preamble. Preamble-C of the burst preamble contains burst information and is captured and stored by the receiver. Preamble-D of the burst preamble contains the length code and is captured by the receiver. Even if the validity bit or bit 1 of byte 0 has been set, the receiver still looks for the sync code in order to record the preamble-C and D values. Once the sync code has not been detected in 4096 frames, the preamble-C and D registers are set to zero.

 The S/PDIF receiver supports the DTS stream. The DTS specifications support frame sizes of 256, 512, 1024, 2048 and 4096. The on-chip S/PDIF receiver supports the 256, 512 and 1024 DTS frames. The DTS test kit frames with 2048 and 4096 frame sizes can be detected by adding the sync detection logic in software by using a software counter to check for the DTS header every 2048 and 4096 frames respectively.

Emphasized Audio Data

The receiver must indicate to the program whether the received audio data is emphasized using the channel status bits as detailed below.

- In professional mode, (bit 0 of byte 0 = 1), channel status bits 2–4 of byte 0 indicate the audio data is emphasized if they are equal to 110 or 111.
- In consumer mode, (bit 0 of byte 0 = 0), channel status bits 3–5 indicate the audio data is emphasized if they are equal to 100, 010 or 110.

If emphasis is indicated in the channel status bits, the receiver asserts the `EMPHASIS` bit flag. This bit flag is used to generate an interrupt.

Single-Channel Double-Frequency Mode

Single-channel, double-frequency mode (SCDF) mode is selected with `DIR_SCDF` and `DIR_SCDF_LR` bits in the `DIRCTL` register. The `DIR_BOCHANL/R` bits in the `DIRSTAT` register also contain information about the SCDF mode. When the `DIR_BOCHANL/R` indicates single channel double frequency mode, the two subframes of a frame carry successive audio samples of the same signal. Bits 0–3 of channel status byte 1 are decoded by the receiver to determine one of the following:

- Single channel double frequency mode
- Single channel double frequency mode–stereo left
- Single channel double frequency mode–stereo right

Clock Recovery Modes

The S/PDIF receiver extracts audio data, channel status, and user bits from the biphasic encoded AES3 and S/PDIF stream. In addition, a 50% duty cycle reference clock running at the sampling rate of the audio input data is generated for the PLL in the receiver to recover the oversampling clock.

Digital On-Chip PLL

The receiver can recover the clock from the biphasic encoded stream using an on-chip digital PLL shown in [Figure 10-5 on page 10-15](#). Note the dedicated on-chip digital PLL is separate from the PLL that supplies the clock to the SHARC processor core and which is the default operation of the receiver.

The left/right frame reference clock for the PLL is generated using the preambles. The recovered low jitter left/right frame clock from the PLL attempts to align with the reference clock. However, this recovered left/right clock, like the reference clock, is not phase aligned with the preambles.

Interrupts

External Analog PLL

Notice there are various performance characteristics to consider when configuring for analog PLL mode. In order to provide the receiver with an external PLL the appropriate routings needs to be performed including the setting of DIR_PLLDIS bit which disables the internal PLL and connects to the external PLL. For more information about using PLLs, visit the Analog Devices Inc. web site at:

<http://www.analog.com/en/clock-and-timing/pll-synthesizersv-cos/products/index.html>

Interrupts

All S/PDIF interrupts are generated by the transmitter and receiver and processed through the DAI interrupt controller which can generate an interrupt signal using the (DAI_IRPTL_x) registers.

Table 10-6 provides an overview of S/PDIF interrupts.

Table 10-6. S/PDIF Interrupt Overview

Interrupt Source	Interrupt Condition	Interrupt Completion	Interrupt Acknowledge	Default IVT
DAI S/PDIF RX/TX (I2S, left/right justified, TDM, 2 channels)	<ul style="list-style-type: none">– TX block start– RX audio status (no audio, status change, emphasis)– RX error (lock, validity, no stream, biphasic, parity, CRC)		Read-to-clear DAI_IRPTL_x + RTI instruction	P0I, P12I (S/PDIF RX only)

Transmitter Interrupt

The DIT_BLKSTART_0 output signal, if routed to any miscellaneous interrupt bits (DAI_INT_31-22 in the SRU_MISCx register), triggers a block start interrupt during the last frame of current block.

Receiver Interrupts

The following three receiver status bits (DAI_IMASK_x) generate an interrupt.

- No audio (DIR_NOAUDIO_INT)
- Emphasized audio (DIR_EMPHASIS_INT)
- Status change (DIR_STATCNG_INT)

Note the status change interrupt is generated if any of the 40 status bits (bytes 4–0) have changed.

Receiver Error Interrupts

The following five receiver error status bits (DAI_IMASK_x) generate an interrupt.

- Receiver Locked (DIR_LOCK_INT)
- Validity (DIR_VALID_INT)
- No Audio Stream (DIR_NOSTREAM_INT)
- CRC Error (DIR_CRCERROR_INT)
- Parity or biphase Error (DIR_ERROR_INT)

Notice that parity error and biphase error are ORed together to form a DIR_ERROR_INT interrupt. The CRCERROR bit is not available in DIRSTAT register. The CRCERROR interrupt latch bit is set whenever the CRCC check of the channel status bits fails. The CRCC check is only performed if channel status bit 0 of byte 0 is high, indicating professional mode.

Debug Features

The following sections describe the features available for debugging the Sony/Philips digital interface.

Loop Back Routing

The S/PDIF supports an internal loopback mode by using the SRU. [For more information, see “Loop Back Routing” on page 6-41.](#)

Effect Latency

The total effect latency is a combination of the write effect latency (core access) plus the peripheral effect latency (peripheral specific).

Write Effect Latency

For details on write effect latency, see *SHARC Processor Programming Reference*.

S/PDIF Effect Latency

The S/PDIF transmit and receive register maximum effect latency is 2.5 PCLK cycles. For transmit, the following apply.

S/PDIF Transmit

TX_CLK to BIPHASE_OUT effect latency.

For TX_SCDF_EN = 0 and the DIT_FREQ1-0 pins =

0 = 2 TX_SCLK cycles

1 = 4 TX_SCLK cycles

2 = 5 TX_SCLK cycles

3 = 7 TX_SCLK cycles

For TX_SCDF_EN = 1 and the DIT_FREQ1-0 pins =

0 = 5 TX_SCLK cycles

1 = 7 TX_SCLK cycles

2 = 9 TX_SCLK cycles

3 = 13 TX_SCLK cycles

MUTE programming to BIPHASE_OUT. MUTE is always synchronized to the edges of LRCLK internally. After synchronizing the MUTE (programmed) signal, the data received on serial interface sampled as zero. Three sub frames (worst case) after MUTE synchronization, the effect (digital black) of MUTE seen on S/PDIF biphasic output (DIT_0).

EXT_SYNC input signal synchronization latency. $2 \times$ (respective latencies as mentioned in case BIPHASE_OUT and MUTE above).

EXT_SYNC_EN effect latency. Respective latencies as mentioned in case BIPHASE_OUT and MUTE above.

S/PDIF Receive

MUTE programming to digital black. Effect latency is 1 LRCLK cycle + 1 digital PLL cycle.

PLL_DISABLE programming to external clock switching. Zero cycle latency.

RESET programming to RESET activation. Zero cycle latency.

Programming Model

The following sections provide information on programming the transmitter and receiver.

Programming the Transmitter

Since the S/PDIF transmitter data input is not available to the core, programming the transmitter is as simple as: 1) connecting the SRU to the on-chip (serial ports or input data port) or off-chip (DAI pins) serial devices that provide the clock and data to be encoded, and 2) selecting the desired mode in the transmitter control register. This setup can be accomplished in three steps.

1. Connect the transmitter's four required input signals and one biphasic encoded output in the SRU. The four input signals are the serial clock (`DIT_CLK_I`), the serial frame sync (`DIT_FS_I`), the serial data (`DIT_DAT_I`), and the high frequency clock (`DIT_HFCLK_I`) used for the encoding. The only output of the transmitter is `DIT_0`.
2. If user bits are required, write 0x1 to the `DITUSRUPD` register for the first block of transfer. Also route the `DIT_BLK_START_0` signal to the any `DAI_INT_31-22` (`DAI_IMASKx` register). This generates interrupts during the last frame of the block (192), allowing changes of user bits for the next block.
3. Initialize the `DITCTL` register to enable the data encoding.
4. Manually set the block start bit in the data stream once per block (384 words). This is necessary if automatic generation of block start information is not enabled in the `DITCTL` register, (`DIT_AUTO = 0`).

Programming the Receiver

Since the S/PDIF receiver data output is not available to the core, programming the peripheral is as simple as connecting the SRU to the on-chip (serial ports or input data port) or off-chip (DAI pins) serial devices that provide the clock and data to be decoded, and selecting the

desired mode in the receiver control register. This setup can be accomplished in two steps.

1. Connect the input signal and three output signals in the SRU for. The only input of the receiver is the biphasic encoded stream, `DIR_I`. The three required output signals are the serial clock (`DIR_CLK_0`), the serial frame sync (`DIR_FS_0`), and the serial data (`DIR_DAT_0`). The high frequency clock (`DIR_TDMCLK_0`) derived from the encoded stream is also available if the system requires it.
2. Initialize the `DIRCTL` register to enable the data decoding. Note that this peripheral is enabled by default.

Interrupted Data Streams on the Receiver

When using the S/PDIF receiver with data streams that are likely to be interrupted, (in other words unplugged and reconnected), it is necessary to take some extra steps to ensure that the S/PDIF receiver's digital PLL will re lock to the stream. The steps to accomplish this are described below.

1. Setup interrupts within the DAI so that the S/PDIF receiver can generate an interrupt when the stream is reconnected.
2. Within the interrupt service routine (ISR), stop and restart the digital PLL. This is accomplished by setting and then clearing bit 7 of the S/PDIF receiver control register.
3. Return from the ISR and continue normal operation.

This method of resetting the digital PLL has been shown to provide extremely reliable performance when S/PDIF inputs that are interrupted or unplugged momentarily occur.

Programming Model

The following procedure and the example code show how to reset the digital PLL. Note that all of the S/PDIF receiver interrupts are handled through the DAI interrupt controller.

1. Initialize the No Stream Interrupt

```
/* Enable interrupts (globally) */
BIT SET MODE1 IRPTEN;
/* unmask DAI Hi=Priority Interrupt */
bit set imask DAIHI;
ustat1 = DIR_NOSTREAM_INT;

/* Enable no-stream Interrupt on Falling Edge. Interrupt
occurs when the stream is reconnected */
dm(DAI_IMASK_FE) = ustat1;

/* Enable Hi-priority DAI interrupt */
dm(DAI_IMASK_PRI) = ustat1;

/* If more than 1 DAI interrupt is being used, it is neces-
sary to determine which interrupt occurred here */

/* Interrupt Service Routine for the DAI Hi-Priority Inter-
rupt. This ISR triggered when the DIR sets no_stream bit */
_DAIisrH:
```

2. Reset the Digital PLL Inside of the ISR

```
r8=dm(DAI_IMASK_H);          /* Reading DAI_IMASK_H
                             clears interrupt */
ustat2=dm(DIRCTL);
bit set ustat2 DIR_PLLDIS; /* bit_7 disables Dpll only */
dm(DIRCTL)=ustat2;
bit clr ustat2 DIR_PLLDIS; /*reenable the digital pll */
dm(DIRCTL)=ustat2;
```

11 PRECISION CLOCK GENERATOR

The precision clock generators (PCG) consist of four units, each of which generates a pair of signals (clock and frame sync) derived from a clock input signal. The units, A B, C, and D, are identical in functionality and operate independently of each other. The two signals generated by each unit are normally used as a serial bit clock/frame sync pair. [Table 11-1](#) lists the PCG specifications.

Table 11-1. PCG Specifications

Feature	PCGA/B	PCGC/D
Connectivity		
Multiplexed Pinout	No	No
SRU DAI Required	Yes	Yes
SRU DAI Default Routing	No	No
SRU2 DPI Required	No	Yes
SRU2 DPI Default Routing	N/A	No
Interrupt Control	No	No
Protocol		
Master Capable	Yes	Yes
Slave Capable	No	No
Transmission Simplex	N/A	N/A
Transmission Half Duplex	N/A	N/A
Transmission Full Duplex	N/A	N/A

Features

Table 11-1. PCG Specifications (Cont'd)

Feature	PCGA/B	PCGC/D
Access Type		
Data Buffer	No	No
Core Data Access	N/A	N/A
DMA Data Access	N/A	N/A
DMA Channels	N/A	N/A
DMA Chaining	N/A	N/A
Boot Capable	N/A	N/A
Local Memory	No	No
Clock Operation	PCLK	PCLK

Features

The following list describes the features of the precision clock generators.

- Operates on the DAI and DPI units.
- PCG input clock selection from `CLKIN`, `PCLK` or external DAI pins.
- Provides 4 different clock dividers for serial clock, frame sync, phase (20-bit) and pulse width (16-bit).
- Phase shift allows to adjust the FS relative to the serial clock, can be shifted the full period and wrap around.
- Pulse width control allows arbitrary frame sync signal generation.
- Bypass mode for external frame sync manipulation.
- External trigger mode starts PCG operation. No additional jitter introduced since operation is independent of the on-chip PLL by using off-chip clocks.

Pin Descriptions

Table 11-2 provides the pin descriptions for the PCGs. Note x = unit A/B/C/D.

Table 11-2. PCG Pin Descriptions

Internal Nodes	I/O	Description
Inputs		
CLKIN	I	External clock input for PCG x
PCLK	I	Internal peripheral clock input for PCG x
PCG_SYNC_CLKx_I	I	External Trigger event input for serial clock and frame sync. An external event with a rising edge can start the PCG operation for SCLK and frame sync.
PCG_EXTx_I	I	External clock A input from DAI provided to the PCG x (not CLKIN)
MISCA2_I	I	External frame sync used for one shot mode PCG A
MISCA3_I	I	External frame sync used for one shot mode PCG B
MISCA4_I	I	External frame sync used for one shot mode PCG C
MISCA5_I	I	External frame sync used for one shot mode PCG D
Outputs		
PCG_CLKx_O	O	Serial clock x output DAI and DPI
PCG_FSx_O	O	Frame sync x output DAI and DPI

SRU Programming

To use the PCG, route the required inputs using the SRU as described in [Table 11-3](#). Also, use the SRU to connect the outputs to the desired DAI pins.

Table 11-3. PCG DAI/SRU Connections

Internal Nodes	DAI Group	DPI Group	SRU Register
Inputs			
PCG_SYNC_CLKA_I PCG_SYNC_CLKB_I PCG_SYNC_CLKC_I PCG_SYNC_CLKD_I PCG_EXT_A_I PCG_EXT_B_I PCG_EXT_C_I PCG_EXT_D_I	Group A		SRU_CLK4 SRU_CLK5
MISCA2_I MISCA3_I MISCA4_I MISCA5_I	Group E		SRU_EXT_MISCA
Outputs			
PCG_CLKA_O PCG_CLKB_O	Group A, D Group A, D, E		
PCG_CLKC_O PCG_CLKD_O	Group D	Group B	
PCG_FSA_O PCG_FSB_O	Group C, D, E		
PCG_FSC_O PCG_FSD_O	Group D	Group B	



A PCG clock output cannot be fed to its own input. Setting $SRU_CLK4[4:0] = 28$ connects PCG_EXT_A_I to logic low, not to PCG_CLKA_O. Setting $SRU_CLK4[9:5] = 29$ connects PCG_EXT_B_I to logic low, not to PCG_CLKB_O. The clock and frame sync signals of

PCG C and D cannot be directly connected to other peripheral clock and frame sync signals. They can only be routed through the DAI pins.

Register Overview

This section provides brief descriptions of the major registers. For complete information see “[Precision Clock Generator Registers](#)” on [page A-111](#).

- **Control Register 0 (PCG_CTLx0)**. Enables the clock and frame sync, it includes the frame sync divider and the upper half of the 20-bit phase value.
- **Control Register 1 (PCG_CTLx1)**. Enables the clock and frame sources, it includes the clock divider and the lower half of the 20-bit phase value.
- **Pulse Width Register (PCG_PWx)**. Contains the pulse width settings for normal mode ($FSDIV > 1$) or control bits for bypass mode ($FSDIV = 1/0$). Enables direct bypass or one shot mode.
- **Frame Synchronization Register (PCG_SYNCx)**. This register enables PCLK as input clock to the PCGs. It also enables external FS trigger mode.

Clocking

The fundamental clock of the PCG is PCLK.

Functional Description

The following sections provide information on the function of the precision clock generators. Figure 11-1 shows a block diagram of the module.

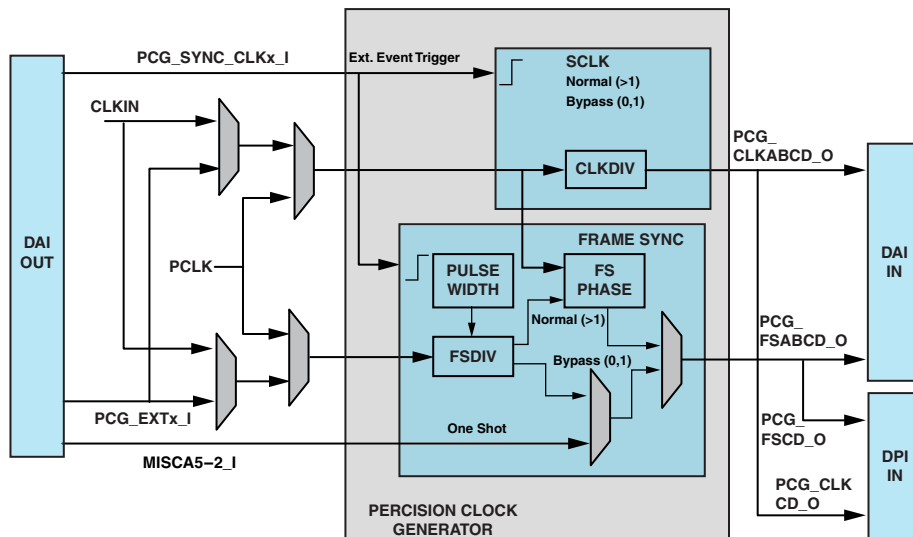

Figure 11-1. PCG Block Diagram

Serial Clock

Each of the four units (A, B, C, and D) produces a clock output. Serial clock generation from a unit is independently enabled and controlled. Sources for the serial clock generation can be either from the `CLKIN`, `PCLK`, or a DAI pin source. The clock output is derived from the input to the PCG with a 20-bit divisor.

Note that the divider is working in normal mode for `CLKDIV > 1`. For `CLKDIV = 0, 1` the divider operates in bypass mode, (input clock is fed directly to its output). Note that in bypass mode, the clock at the output

can theoretically run at up to the $PCLK$ frequency. However the DAI/DPI pin buffers limit the speed to $PCLK/4$.

Note that the clock output is always set (as closely as possible) to a 50% duty cycle. If the clock divisor is even, the duty cycle of the clock output is exactly 50%. If the clock divisor is odd, then the duty cycle is slightly less than 50%. The low period of the output clock is one input clock period more than the high period of the output clock. For higher values of an odd divisor, the duty cycle is close to 50%.

 A PCG clock output cannot be fed to its own input.

Frame Sync

The following sections describe the use of frame syncs in the PCGs.

Frame Sync Output

Each of the four units (A through D) also produces a synchronization signal for framing serial data. The frame sync outputs are much more flexible since they need to accommodate the wide variety of serial protocols used by peripherals.

Frame sync generation from a unit is independently enabled and controlled. Sources for the frame sync generation can be either from the crystal buffer output, $PCLK$, or an external pin source. There is only one external source pin for both frame sync and clock output for a unit.

If an external source is selected for both frame sync and clock output for a unit, then they operate on the same input signal. Apart from enable and source select control bits, frame sync generation is controlled by a 20-bit divisor.

Functional Description

Divider Mode Selection

If frame sync divisor > 1 the PCG frame sync output frequency is equal to the input clock frequency, divided by a 20-bit integer. This integer is specified in the `FSDIV` bit field (bits 19–0 of the `PCG_CTLX0` register).

However if the frame sync divisor is zero or one, the PCG's frame sync clock generation unit is bypassed, and the frame sync input is connected directly to the frame sync output. For `FSDIV=0, 1` the `PCG_PWX` registers have different functionality than in normal mode.

Phase Shift

Phase shift is a frame sync parameter that defines the phase shift of the frame sync with respect to the input clock of the same unit. This feature allows shifting of the frame sync signal in time relative to the clock input signal. Frame sync phase shifting is often required by peripherals that need a frame sync signal to lead or lag a clock signal.

For example, the I²S protocol specifies that the frame sync transition from high to low occur one clock cycle before the beginning of a frame. Since an I²S frame is 64 clock cycles long, delaying the frame sync by 63 cycles produces the required framing.

Phase shifting is represented as a full 20-bit value so that even when the frame sync is divided by the maximum amount, the phase can be shifted to the full range, from zero to one input clock short of the period.



Phase shifting is specified as a 2x10-bit divider value in the `FSX-PHASE_HI` bit field (bits 29–20) of the `PCG_CTLX0` register and in the `FSXPHASE_LO` bit field (bits 29–20) of the `PCG_CTLX1` register.

A single 20-bit value spans these two bit fields. The upper half of the word (bits 19–10) is in the `PCG_CTLX0` register, and the lower half (bits 9–0) is in the `PCG_CTLX1` register.

The phase shift between clock and frame sync outputs may be programmed using the `PCG_PW` and `PCG_CTLxx` registers under these conditions:

- The input clock source for the clock generator output and the frame sync generator output is the same.
- The clock and frame sync are enabled at the same time using a single atomic instruction.
- The frame sync divisor is an integral multiple of the clock divisor.



When using a clock and frame sync as a synchronous pair, the units must be enabled in a single atomic instruction before their parameters are modified. Both units must also be disabled in a single atomic instruction as shown below.

```
r0 = CLKDIV_A|PHASE_LO_A;
dm(PCG_CTLA1) = r0;
r0 = FSDIV_A|PHASE_HI_A|ENCLKA|ENFSA;
/* program dividers and enable CLK and FS */
dm(PCG_CTLA0) = r0;
```

If the phase shift is zero (see [Figure 11-2](#)), the clock and frame sync outputs rise at the same time. If the phase shift is one, the frame sync output transitions one input clock period ahead of the clock transition. If the phase shift is divisor – 1, the frame sync transitions divisor – 1 input clock periods ahead of the clock transitions

Pulse Width

Pulse width is the number of input clock periods for which the frame sync output is high.

A 16-bit value determines the width of the framing pulse. Settings for pulse width can range from zero to `DIV – 1`. The pulse width should be less than the divisor of the frame sync. The pulse width of frame sync is specified in the `PWFSx` bits (15–0) and (31–16) of the `PCG_PWx` registers.

Functional Description

Default Pulse Width

If the pulse width count is equal to 0 and if `FSDIV` bit field is even, then the actual pulse width of the frame sync output is equal to:

For even divisors: $\text{frame sync divisor}/2$

If the pulse width count is equal to 0 and if `FSDIV` bit field is odd, then the actual pulse width of the frame sync output is equal to:

For odd divisors: $\text{frame sync divisor} - 1/2$

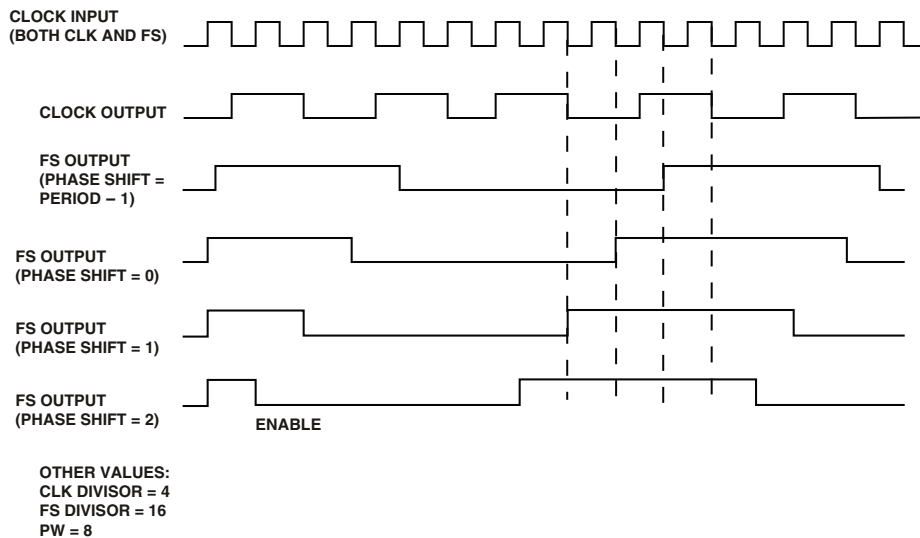

Figure 11-2. Phase and Pulse Width Settings

Timing Example for I2S Mode

As per the I²S mode, frame sync should be driven at the falling edge of `SCLK`. In other words, frame sync edge should coincide with the falling edge of the `SCLK`. To satisfy this requirement, the phase of the frame sync should be programmed accordingly in the `PCG_CTLxx` registers.

For example assume that the input clock source for both clock and frame sync is the same and both CLK and frame sync are enabled at the same time. Also assume that the clock divisor value needed to generate the required SCLK is $CLKDIV = 4$. Then, for 32-bit word length, the frame sync divisor value for should be $FSDIV = 64 \times CLKDIV = 256$.

By default, for phase = 0, the rising edge of both SCLK and frame sync will coincide. To make sure that the frame sync edges coincides with the falling edge of the SCLK, the phase value needs to be programmed as $CLKDIV/2 = 2$. It can be done by following instructions:

```
ustat1=CLKDIV|((CLKDIV/2) << 20);  
dm(PCG_CTLx1) = ustat1;
```

For details on how to program phase of the frame sync see [“Programming Model” on page 11-19](#).

Operating Modes

The following sections provide information on the operating modes of the precision clock generator.

Normal Mode

When the frame sync divisor is set to any value other than zero or one, the PCGs operates in normal mode. In normal mode, the frequency of the frame sync output is determined by the divisor where:

$$\text{Frequency of Frame Sync Output} = \left(\frac{\text{Input Frequency}}{\text{Divisor}} \right)$$

The high period of the frame sync output is controlled by the value of the pulse width control. The value of the pulse width control should be less than the value of the divisor.

Operating Modes

The phase of the frame sync output is determined by the value of the phase control. If the phase is zero, then the positive edges of the clock and frame sync coincide when:

- the clock and frame sync dividers are enabled at the same time using an atomic instruction
- the divisors of the clock and frame sync are the same
- the source for the clock and frame sync is the same

The number of input clock cycles that have already elapsed before the frame sync is enabled is equal to the difference between the divisor and the phase values. If the phase is a small fraction of the divisor, then the frame sync appears to lead the clock. If the phase is only slightly less than the frame sync divisor, then the frame sync appears to lag the clock. The frame sync phase should not be greater than the divisor.

Bypass Mode

When the frame sync divisor for the frame sync has a value of zero or one, the frame sync is in bypass mode, and the `PCG_PWx` registers have different functionality than in normal mode.

 In normal mode bits 15–0 and 31–18 of the `PCG_PWx` registers are used to program the pulse width count. In bypass mode bits 15–2 and 31–18 are ignored. Bits 1–0 and 17–16 are renamed to `STROBEx` and `INVFSx` respectively. This is described in more detail below.

If the `STROBEx` bit of `PCG_PWx` register is cleared, then the input is directly passed (see [Figure 11-3](#)) to the frame sync output either inverted or not inverted, depending on the `INVFSx` bit of the `PCG_PWx` registers.

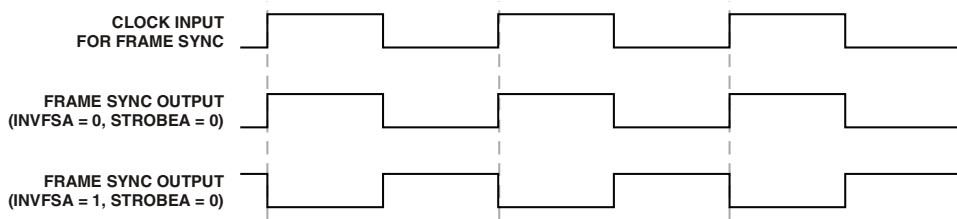

Figure 11-3. Bypass and Inverted Bypass

One-Shot Mode

In one-shot mode operation, the PCG produces a series of periods but does not run continuously.

Bypass mode also enables the generation of a strobe pulse (one shot frame sync). Strobe usage ignores the divider counters and looks to the SRU to provide the input signal. Two bit fields determine the operation in this mode.

In the bypass mode, if the `STROBEx` bit of `PCG_PWx` register is set to 1, then a one-shot pulse is generated. This one-shot pulse has the duration equal to the period of `MISCAx_I` for the `PCGx` unit. This pulse is generated either at the falling or rising edge of the input clock, depending on the value of the `INVFSx` bit of the `PCG_PW` register. The output pulse width is equal to the period of the SRU source signal `MISCAx_I`. The pulse begins at the second rising edge of `MISCAx_I` following a rising edge of the clock input. When the `INVFSx` bit is set, the pulse begins at the second rising edge of `MISCAx_I` coinciding with or following a falling edge of the clock input.



Notice a strobe period is defined to be the period of the frame sync input clock signal specified by the `FSxSOURCE` bit (`PCG_CTLx1` registers).

Operating Modes

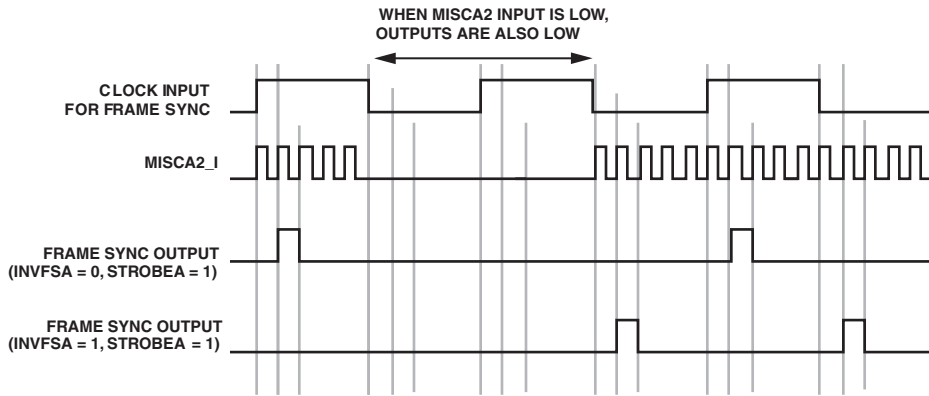

Figure 11-4. One Shot Mode PCG A (MISCA2_I input)

External Event Trigger

The trigger with the external clock is enabled by setting bits 0 and 16 of the PCG_SYNC register.

Since the rising edge of the external clock is used to synchronize with the frame sync, the frame sync output is not generated until a rising edge of the external clock is sensed (Figure 11-5).

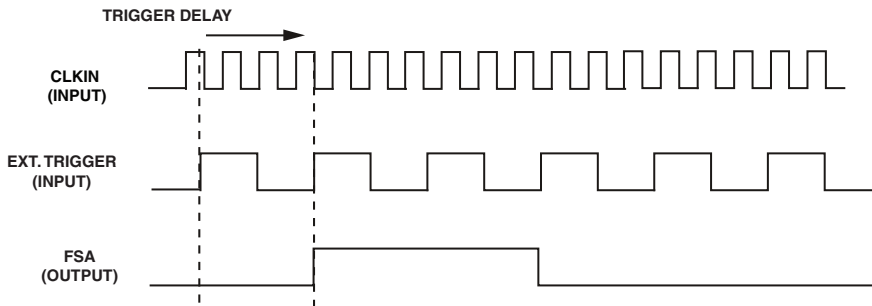

Figure 11-5. FS Output Synchronization With External Trigger Input

External Event Trigger Delay

The time delay between the rising trigger edge and the start of SCLK/FS varies between 2.5 to 3.5 input clock periods. If the input clock and the trigger signal are synchronous, the delay is 3 input clock periods. The following cases need to be considered:

- PCLK is the input source. In this case if the given trigger event is synchronous to PCLK, the delay is 3 PCLK periods. If the trigger signal is asynchronous with PCLK, the delay varies from 2.5 PCLK periods to 3.5 PCLK periods. (It depends on whether the trigger edge occurs in the positive half cycle or negative half cycle of PCLK.)
- CLKIN is the input source. In this case if the given trigger signal is synchronous to CLKIN, the delay is 3 CLKIN periods. But if they are asynchronous to CLKIN, the delay can vary between 2.5 CLKIN periods to 3.5 CLKIN periods.
- SRU is the input source. If the input clock and trigger signal are synchronous, the delay is exactly 3 input clock periods. If asynchronous, it varies between 2.5 to 3.5 input clock periods depending on the phase difference between the input clock and trigger signal.

Audio System Example

Figure 11-6 shows an example of the internal interconnections between the SPDIF receiver, ASRC, and the PCGs. The interconnections are made by programming the signal routing unit.

It shows how to set up two precision clock generators using the S/PDIF receiver and an asynchronous sample rate converter (ASRC) to interface to an external audio DAC. The PCG is configured to provide a fixed ASRC/DAC output sample rate of 65.098 kHz. The input to the S/PDIF receiver is typically 44.1 kHz if supplied by a CD player, but can also be from other source at any nominal sample rate from about 22 kHz to 192

Operating Modes

kHz. Similarly, the phase shift for frame syncs B, C, and D is specified in the corresponding `PCG_CTLx0` and `PCG_CTLx1` registers.

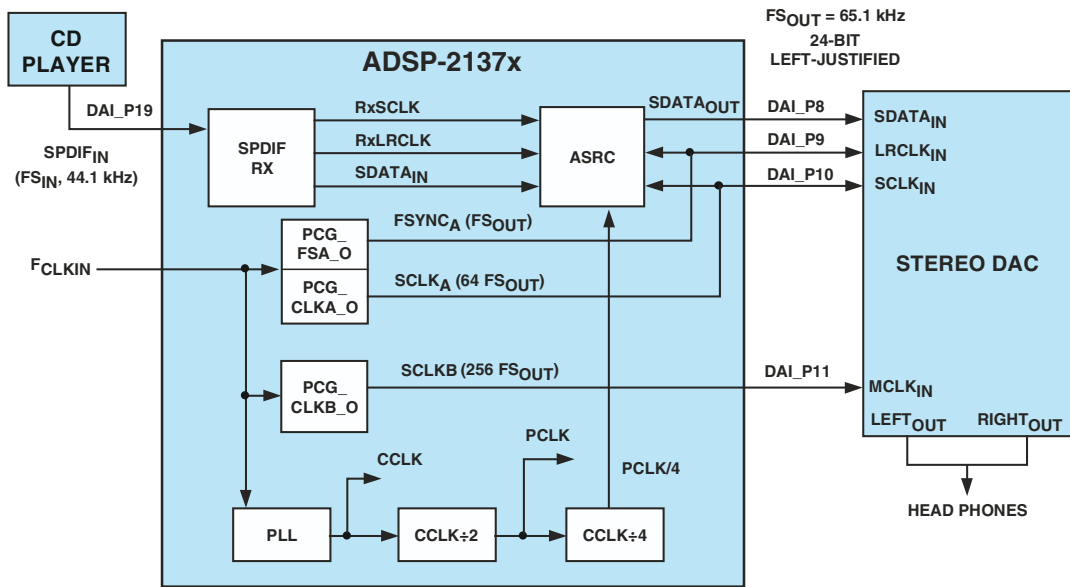

Figure 11-6. PCG Setup for I2S or Left-Justified DAI

Three synchronous clocks are required in audio systems

1. Frame sync (FS)
2. Serial bit clock (64 x FS)
3. Master DAC clock (256 x FS)

Since each PCG has only two outputs, this example requires two PCGs. Furthermore, because the digital audio interface requires a fixed-phase relation between `SCLK` and `FS`, these two outputs should come from one PCG (PCG A) while the master clock comes from the 2nd (PCG B).

The combined PCGs can provide a selection of synchronous clock frequencies to support alternate sample rates for the ASRCs and external DACs. However, the range of choices is limited by `CLKIN` and the ratio of `PCG_CLKx_0:SCLK:FS` which is normally fixed at 256:64:1 to support digital audio left-justified, I²S and right-justified interface modes.

Many DACs also support 384, 512, and 786x FS for `PCG_CLKx_0`, which allows some additional flexibility in choosing `CLKIN`.

Note the falling edge of `SCLK` must always be synchronous with both edges of FS. This requires that the phase of the `SCLK` and FS signals for a common PCG (PCG A) be adjustable.

While the frequency of the master DAC clock (`PCG_CLKx_0`) must be synchronous with the sample rate supplied to the external DAC, there is no fixed phase requirement.

Set the clock divisor and source and low-phase word first, followed by the control register enable bits, which must be set together. When the `PCG_PW` register is set to zero (default) the FS pulse width is $(\text{divisor} \div 2)$ for even divisors and $(\text{divisor} - 1) \div 2$ for odd divisors. Alternatively, the `PCG_PW` register could be set high for exactly one-half the period of `CLKIN` cycles for a 50% duty cycle, provided the frame sync divisor is an even number.

Clock Configuration Examples

For a `CLKIN` = 33.330 MHz the two PCGs provide the three synchronous clocks `PCGx_CLK`, `SCLK` and `FS` for the SRCs and external DAC. These divisors are stored in 20-bit fields in the `PCG_CTL` registers.

The integer divisors for several possible sample rates based on 33.330 MHz `CLKIN` are shown in [Table 11-4](#).

Effect Latency

Table 11-4. Precision Clock Generator Division Ratios
(33.330 CLKIN)

Sample Rate kHz)	PCG Divisors		
	CLKDIV B	CLKDIV A	FSDIV A ¹
130.195	1	4	256
65.098	2	8	512
43.398	3	12	768
32.549	4	16	1024
26.039	5	20	1280
21.699	6	24	1536
18.599	7	28	1792

1 The frame sync divisor should be an even integer in order to produce a 50% duty cycle waveform. See “[Frame Sync](#)” on page 11-7.

For more information on core clock setting, see “[Power Management Control Registers \(PMCTL\)](#)” on page A-7.

Effect Latency

The total effect latency is a combination of the write effect latency (core access) plus the peripheral effect latency (peripheral specific).

Write Effect Latency

For details on write effect latency, see *SHARC Processor Programming Reference*.

PCG Effect Latency

After the PCG registers are configured the effect latency is shown below. The latency to start the `CLKOUT` depends on the divisor value and input source as described below.

Input clock through `PCLK`

- If divisor value is 0 or 1 (bypassed) the latency is 1 `PCLK` cycle
- For other divisor values the latency is 3 `PCLK` cycles

Input clock through `CLKIN`

- If divisor is 0 or 1 (bypassed) the latency can vary from 0 to 1 oscillator period. This is because clock generation starts with the immediate positive edge of the `CLKIN`.
- For other divisor values the latency can vary between 2 to 3 oscillator periods. This is because clock generation starts with the third positive edge of `CLKIN`.

Input clock through `SRU`

- If divisor is 0 or 1 (bypassed) the latency can vary from 0 to 1 input clock period. For example if the input clock has a period of 100 ns then this latency can be a maximum of 100 ns.
- For other divisor values the latency can vary between 2 to 3 input clock periods. For example if the input clock has a period of 100 ns then this latency can be between 200 and 300 ns.

Programming Model

The section describes which sequences of software steps required for successful PCG operation.

Frame Sync Phase Setting

The phase unit requires that the clock and FS is enabled simultaneously in an atomic instruction.

1. Write the clock divider/low 10-bit Phase divider to `PCG_CTLx1` register.
2. Program the FS divider/high 10-bit Phase divider, enable both the `ENCLKx` and `ENFSx` bits in the `PCG_CTLx0` registers.

Note that both units must be disabled in the same way.

External Event Trigger

The trigger with the external clock is enabled by setting bits 0 and 16 of the `PCG_SYNC` register. The phase must be programmed to 3, so that the rising edge of the external clock is in sync with the frame sync (Figure 11-5).

Programming should occur in the following order.

1. Program the `PCG_SYNC` and the `PCG_CTLA0-1`, `PCG_CTLB0-1` registers appropriately.
2. Enable clock or frame sync, or both.

Since the rising edge of the external clock is used to synchronize with the frame sync, the frame sync output is not generated until a rising edge of the external clock is sensed.

Debug Features

Care should be taken in cases where any input to the phase unit is modified. Any individual change of the `CLKDIV` or `FSDIV` dividers may cause a failure in PCG sync operation between the serial clock and the frame sync. Only the programming model ensures a correct setup for phase settings.

Debug Features

12 SERIAL PERIPHERAL INTERFACE PORTS

The processors are equipped with two synchronous serial peripheral interface ports that are compatible with the industry-standard serial peripheral interface (SPI). Each SPI port also has its own set of registers (the secondary register set contains a B as in `SPIBAUDB`). The SPI ports support communication with a variety of peripheral devices including CODECs, data converters, sample rate converters, S/PDIF or AES/EBU digital audio transmitters and receivers, LCDs, shift registers, microcontrollers, and FPGA devices with SPI emulation capabilities. The interface specifications are shown in [Table 12-1](#).

Table 12-1. SPI Port Specifications

Feature	SPI/SPIB
Connectivity	
Multiplexed Pinout	No
SRU DAI Required	No
SRU DAI Default Routing	N/A
SRU2 DPI Required	Yes
SRU2 DPI Default Routing	Yes
Interrupt Control	Yes
Protocol	
Master Capable	Yes
Slave Capable	Yes
Transmission Simplex	Yes
Transmission Half Duplex	Yes

Features

Table 12-1. SPI Port Specifications (Cont'd)

Feature	SPI/SPIB
Transmission Full Duplex	Yes (Core and DMA)
Access Type	
Data Buffer	Yes
Core Data Access	Yes
DMA Data Access	Yes
DMA Channels	1
DMA Chaining	Yes
Boot Capable	Yes
Local Memory	No
Clock Operation	PCLK/4 (slave), PCLK/8 (master)

Features

The processor's SPI ports provide the following features and capabilities.

- A simple 4-wire interface consisting of two data pins, a device select pin, and a clock pin.
- Special data formats to accommodate little and big endian data, different word lengths, and packing modes.
- Master and multiples slave (multi devices) in which the ADSP-2136x and ADSP-2137x master processor can be connected to up to four other SPI devices.
- Parallel core and DMA access allow full duplex operation.
- Open drain outputs to avoid data contention and to support multimaster scenarios.

- Programmable baud rates, clock polarities, and phases (SPI mode 0–3).
- Master or slave booting from a master SPI device. See “[SPI Port Booting](#)” on page 17-12.
- DMA capability to allow transfer of data without core overhead. See “[DMA Transfers](#)” on page 12-20.
- Internal loopback mode (by connecting MISO to MOSI).

Note the SPI interface does not support daisy chain operation, where the MOSI and MISO pins are internally connected through a FIFO, allowing bypass of data streams.

Pin Descriptions

The SPI protocol uses a 4-wire protocol to enable full-duplex serial communication. [Table 12-2](#) provides detailed pin descriptions and [Figure 12-1](#) shows the master-slave connections between two devices.

Table 12-2. SPI Pin Descriptions

Internal Node	Type	Description
SPI_CLK_I/O SPIB_CLK_I/O	I/O	SPI Clock Signal. This control line is clock driven by the master and regulates the flow of the data bits. The master may transmit data at a variety of baud rates. The CLK line cycles once for each bit that is transmitted. It is an output signal if the device is configured as a master; it is an input signal if configured as a slave.
SPI_DS_I SPIB_DS_I	I	SPI Slave Device Select. This is an active-low input signal that is used to enable slave devices. This signal is like a chip select signal for the slave devices and is provided by the master device. For a master device, it can act as an error input signal in a multi-master environment. In multi-master mode, if the SPI_DS_I input signal of a master is asserted (Low) an error has occurred. This means that another device is also trying to be the master.

SRU Programming

Table 12-2. SPI Pin Descriptions (Cont'd)

Internal Node	Type	Description
SPI_MOSI_I/O SPIB_MOSI_I/O	I/O	SPI Master Out Slave In. This data line transmits the output data from the master device and receives the input data to a slave device. This data is shifted out from the MOSI pin of the master and shifted into the MOSI input(s) of the slave(s).
SPI_MISO_I/O SPIB_MISO_I/O	I/O	SPI Master In Slave Out. This data line transmits the output data from the slave device and receives the input data to the master device. This data is shifted out from the MISO pin of the slave and shifted into the MISO input of the master. There may be no more than one slave that is transmitting data during any particular transfer.
SPI_FLG3-0_O SPIB_FLG3-0_O	O	SPI Slave Select Out. The slave select pins are used to address up to 4 slaves in a multi device system. This functionality can be routed to any of the DPI pins. This frees up the multiplexed core flags for other purposes.
SPI_CLK_P-BEN_O SPIB_CLK_P-BEN_O SPI_MOSI_P-BEN_O SPIB_MOSI_P-BEN_O SPI_MISO_P-BEN_O SPIB_MISO_P-BEN_O SPI_FLG3-0_P-BEN_O SPIB_FLG3-0_P-BEN_O	O	SPI Pin buffer Enable Out Signal. Only driven in master mode. The SPIx_FLGx_PBEN_O signals are enabled if the corresponding DSxEN bits in the SPIFLAG register are set.

SRU Programming

Both SPI and SPIB signals are available through the SRU2, and are routed as described in [Table 12-3](#).

Since the SPI supports a gated clock, it is recommended that programs enable the SPI clock output signal with its related pin buffer enable. This can be done using the macro SRU (SPI_CLK_PBEN_0, PBEN_03_I). If these signals are routed statically high as in SRU (high, PBEN_03_I) some SPI timing modes that are based on polarity and phase may not work correctly because the timing is violated.

Table 12-3. SPI DPI/SRU2 Signal Connections

Internal Node	DPI Group	SRU2 Register
Inputs		
SPI_CLK_I SPIB_CLK_I SPI_DS_I SPIB_DS_I SPI_MOSI_I SPIB_MOSI_I SPI_MISO_I SPIB_MISO_I	Group A	SRU2_INPUT1-0
Outputs		
SPI_CLK_O SPIB_CLK_O SPI_MOSI_O SPIB_MOSI_O SPI_MISO_O SPIB_MISO_O SPI_FLG3-0_O SPIB_FLG3-0_O	Group B	
SPI_CLK_PBEN_O SPIB_CLK_P- BEN_O SPI_MOSI_PBEN_O SPIB_- MOSI_PBEN_O SPI_MISO_PBEN_O SPIB_MISO_PBEN_O SPI_FLG3-0_PBEN_O SPIB_- FLG3-0_PBEN_O	Group C	

Register Overview

This section provides brief descriptions of the major registers. For complete information see [“Serial Peripheral Interface Registers” on page A-144](#).

SPI Control (SPICTLx). Configures the fundamental transfer initiation mode (core or DMA) and configure timing bits and enable the SPI port.

SPI DMA Control (SPIDMACx). Controls the DMA channels on the SPI. Corresponding status bits provide status or error information on transmission.

SPI Flag (SPIFLAGx). Enables the chip selects output in master mode and returns status for errors in multiprocessor systems.

SPI Status (SPISTATx). Provides information on transmission errors for the core.

SPI Baud Rate (SPIBAUDx). For master devices, the clock rate is determined by the 15-bit value of the baud rate registers (SPIBAUDx) as shown in [Table 12-4](#). For slave devices, the value in the SPIBAUDx register is ignored.

Clocking

The fundamental timing clock of the SPI module is peripheral clock/4 ($PCLK/4$) for slave mode and peripheral clock/8 ($PCLK/8$) for master mode. In master mode the settings define the SPI master clock. For information on setting the baud rate, see [Table 12-4](#).

Table 12-4. SPI BAUD Rate – PCLK = 200 MHz

BAUDR Bit Setting	Divider	SPICLK
0	N/A	N/A
1	4	25
2	8	16.66
3	12	8.33
4	16	6.25
25	100	1.0 (master boot)
32,767	262,136	762 Hz

Choosing the Pin Enable for the SPI Clock

When using the SPI in master mode, and the `SPIxCLK` signal is routed onto the DPI pin, then the `DPI_PBenxx_I` signal for that DPI pin being used for the clock must be connected to high.

However, depending on the SPI mode being used (based on the setting of `CPHASE` and `CLKPL` bits in the `SPICTL` register), `SPIx_CLK_PBen_0` signal may be used.

Choosing the correct pin enable ensures that the very first edge on `SPIx_CLK` (DPI pin) output is not incorrectly chosen as a sampling edge by the slave SPI. [Table 12-5](#) shows the correct pin enable to use for a chosen SPI mode.

Functional Description

Table 12-5. Pin Enable Selection by Mode

Mode	CLKPL	CPHASE	Pin Enable
0	0	0	HIGH
1	0	1	HIGH
2	1	0	SPI _x _CLK_PBEN_O
3	1	1	SPI _x _CLK_PBEN_O

All other SPI signals SPI_x_MOSI, SPI_x_MISO and SPI_x_FLG_x signals when routed on the DPI pins, the SPI_x_MISO_PBEN_0, SPI_x_MOSI_PBEN_0, or SPI_x_FLG_PBEN_0 signals should be connected to corresponding DPI_PBEN_{xx}_I signals. The DPI_PBEN_{xx}_I signals should not be statically connected to high, as it affects the functioning of certain bits in the SPICTL_x register.

Functional Description

Each SPI interface contain its own transmit shift (TXSR, TXSRB) and receive shift (RXSR, RXSRB) registers (not user accessible). The TXSR_x registers serially transmit data and the RXSR_x registers receive data synchronously with the SPI clock signal (SPICLK). [Figure 12-1](#) shows a block diagram of the SHARC processor SPI interface. The data is shifted into or out of the shift registers on two separate pins: the master in slave out (MISO) pin and the master out slave in (MOSI) pin.

During data transfers, one SPI device acts as the SPI master by controlling the data flow. It does this by generating the SPICLK and asserting the SPI device select signal (SPI_DS_1). The SPI master receives data using the MISO pin and transmits using the MOSI pin. The other SPI device acts as the SPI slave by receiving new data from the master into its receive shift register using the MOSI pin. It transmits requested data out of the transmit shift register using the MISO pin.

Each SPI port contains a dedicated transmit data buffer (TXSPI, TXSPIB) and a receive data buffer (RXSPI, RXSPIB). Transmitted data is written to TXSPIx and then automatically transferred into the transmit shift register. Once a full data word has been received in the receive shift register, the data is automatically transferred into RXSPIx, from which the data can be read. When the processor is in SPI master mode, programmable flag pins provide slave selection. These pins are connected to the SPI_DS_I of the slave devices.

The SPI has a single DMA engine which can be configured to support either an SPI transmit channel or a receive channel, but not both simultaneously. Therefore, when configured as a transmit channel, the received data is essentially ignored. When configured as a receive channel, what is transmitted is irrelevant. A 4-word deep FIFO is included to improve throughput on the IOD0 bus.

Functional Description

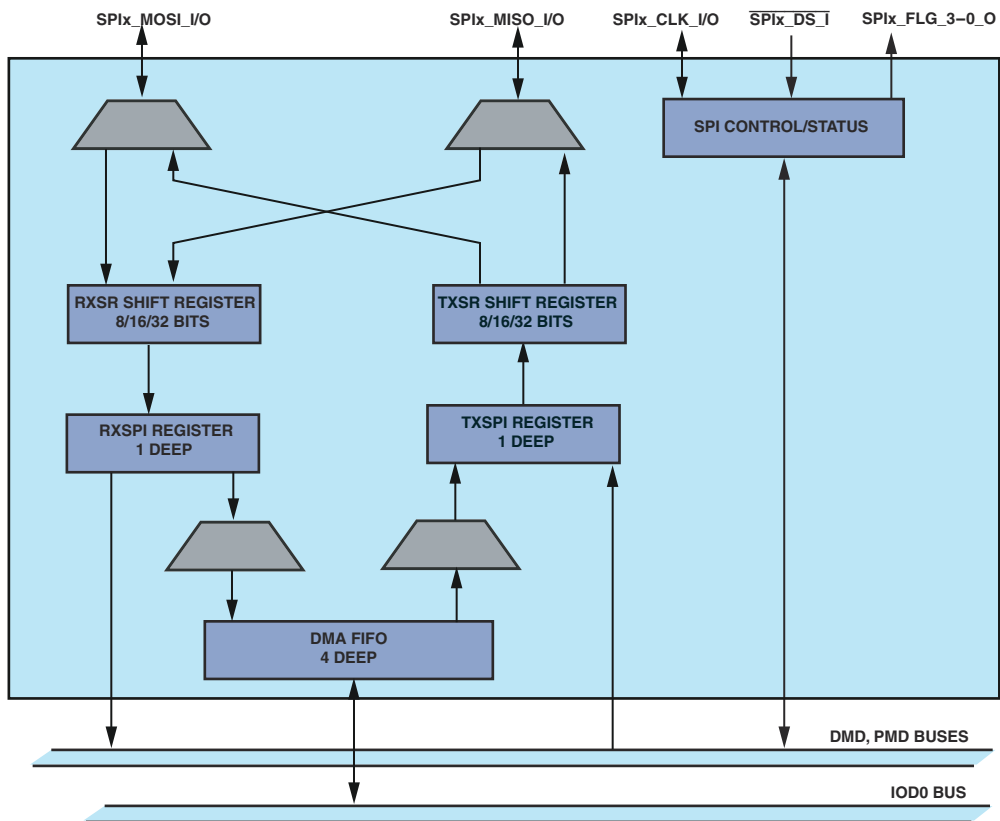

Figure 12-1. SPI Block Diagram

Single Master Systems

Figure 12-2 illustrates how the SHARC processor can be used as the slave SPI device. The 16-bit host (A Blackfin ADSP-BF53x processor) is the SPI master. The processor can be booted via its SPI interface to allow application code and data to be downloaded prior to runtime.

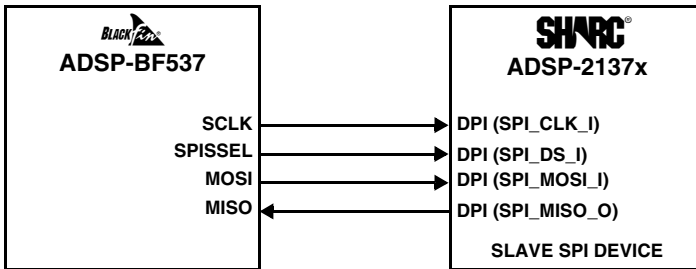

Figure 12-2. SHARC Processor as SPI Slave

Figure 12-3 shows an example SPI interface where the SHARC processor is the SPI master. With the SPI interface, the processor can be directed to alter the conversion resources, mute the sound, modify the volume, and power down the AD1855 stereo DAC.

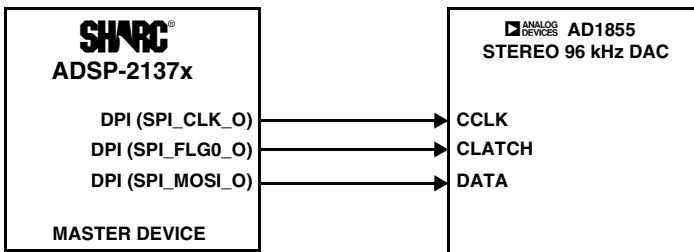

Figure 12-3. SHARC Processor as SPI Master

Multi Master Systems

The SPI does not have an acknowledgement mechanism to confirm the receipt of data. Without a communication protocol, the SPI master has no knowledge of whether a slave even exists. Furthermore, the SPI has no flow control.

Slaves can be thought of as input/output devices of the master. The SPI does not specify a particular higher-level protocol for bus mastership. In some applications, a higher-level protocol, such as a command-response

Functional Description

protocol, may be necessary. Note that the master must initiate the frames for both its' command and the slave's response.

Multi master mode allows an SPI system to transfer mastership from one SPI device to another. In a multi device SPI configuration, several SPI ports are connected and any one (but only one) of them can become a master at any given time.

In this configuration, every `MOSI` pin in the SPI system is connected. Likewise, every `MISO` pin in the system is on a single node, and every `SPICLK` pin should be connected (see [Figure 12-4](#)). SPI transmission and reception are always enabled simultaneously, unless the broadcast mode has been selected.

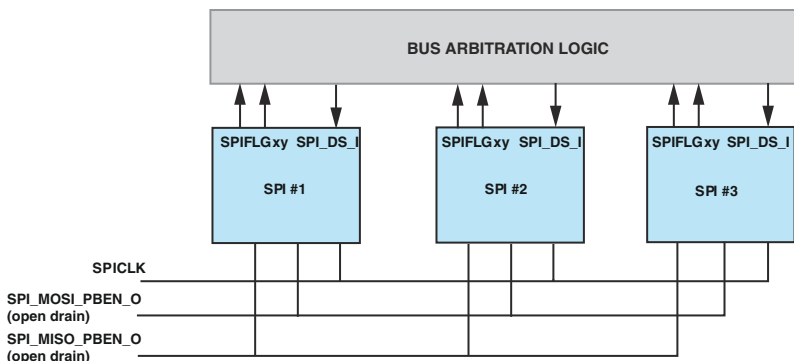

Figure 12-4. Multi Master System

The master's `FLAGx` pins connect to each of the slave SPI devices in the system via their `SPI_DS_I` pins. To enable the different slaves, connect the slave `SPI_DS_I` pins to the DPI pins of the master SHARC. Since these flags are NOT open drain, slave select pins cannot be shorted together in multi master environment. To control slave selects, an external glue logic is required in a multi-master environment.

Another feature is implemented to trouble shoot the bus mastership protocol. If a recent SHARC bus master receives an invalidly asserted

SPI_DS_I signal, it triggers an error handling scenario using the MME bit (SPIMME bit for DMA) and ISSEN bit to reconfigure the SPI to slave mode, and jump into an ISR. This ensures that any potential driver conflict is solved. For more information, see “Control Registers (SPICTL, SPICTLB)” on page A-144.

Operating Modes

This sections describes the different mechanisms used for master or slave select operation modes.

Transfer Initiate Mode

When the processor is enabled as a master, the initiation of a transfer is defined by the TIMOD bits (1–0). Based on these two bits and the status of the interface, a new transfer is started upon either a read of the RXSPIx registers or a write to the TXSPIx registers. This is summarized in Table 12-6.

Table 12-6. Transfer Initiation

TIMOD	Function	Transfer Initiated Upon	Action, Interrupt
00	Core Receive and Transmit	Initiate new single word transfer upon read of RXSPI and previous transfer completed. The SPICLK is generated after the data is read from the buffer. In this configuration, a dummy read is needed initially to receive all the data transmitted from the transmitter.	The SPI interrupt is latched in every core clock cycle in which the RXSPI buffer has a word in it. Emptying the RXSPI buffer or disabling the SPI port at the same time (SPIEN = 0) stops the interrupt latch.
01	Core Transmit and Receive	Initiate new single word transfer upon write to TXSPI and previous transfer completed.	The SPI interrupt is latched in every core clock cycle in which the TXSPI buffer is empty. Writing to the TXSPI buffer or disabling the SPI port at the same time (SPIEN = 0) stops the interrupt latch.

Operating Modes

Table 12-6. Transfer Initiation (Cont'd)

TIMOD	Function	Transfer Initiated Upon	Action, Interrupt
10	Transmit or Receive with DMA	Initiate new multiword transfer upon write to DMA enable bit. Individual word transfers begin with either a DMA write to TXSPI or a DMA read of RXSPI depending on the direction of the transfer as specified by the SPIRCV bit.	If chaining is disabled, the SPI interrupt is latched in the cycle when the DMA count decrements from 1 to 0. If chaining is enabled, interrupt function is based on the PCI bit in the CP register. If PCI = 0, the SPI interrupt is latched at the end of the DMA sequence. If PCI = 1, then the SPI interrupt is latched after each DMA in the sequence. For more information, see “Internal Memory to Internal Memory” on page 2-20.
11	Reserved		

SPI Modes

The SPI supports four different combinations of serial clock phases and polarity called SPI modes. The application code can select any of these combinations using the CLKPL and CPHASE bits (10 and 11).

[Figure 12-5 on page 12-15](#) shows the transfer format when CPHASE = 0 and [Figure 12-6 on page 12-16](#) shows the transfer format when CPHASE = 1. Each diagram shows two waveforms for SPICLK—one for CLKPL = 0 and the other for CLKPL = 1. The diagrams may be interpreted as master or slave timing diagrams since the SPICLK, MISO, and MOSI pins are directly connected between the master and the slave. The MISO signal is the output from the slave (slave transmission), and the MOSI signal is the output from the master (master transmission).

The SPICLK signal is generated by the master, and the SPI_DS_I signal represents the slave device select input to the processor from the SPI master. The diagrams represent 8-bit transfers (WL = 0) with MSB first (MSBF = 1). Any combination of the WL and MSBF bits of the SPICTL register is allowed.

For example, a 16-bit transfer with the LSB first is one possible configuration.

The clock polarity and the clock phase should be identical for the master device and slave devices involved in the communication link. The transfer format from the master may be changed between transfers to adjust to various requirements of a slave device.

i When $CPHASE = 0$, the slave-select line, SPI_DS_I , must be inactive (HIGH) between each word in the transfer. Even in SPI slave mode when $CPHASE = 0$, the master should de assert the SPI_DS_I line between each transfer. When $CPHASE = 1$, SPI_DS_I may either remain active (LOW) between successive transfers or be inactive (HIGH).

Figure 12-5 shows the SPI transfer protocol for $CPHASE = 0$. Note that $SPICLK$ starts toggling in the middle of the data transfer where the bit settings are $WL = 0$, and $MSBF = 1$.

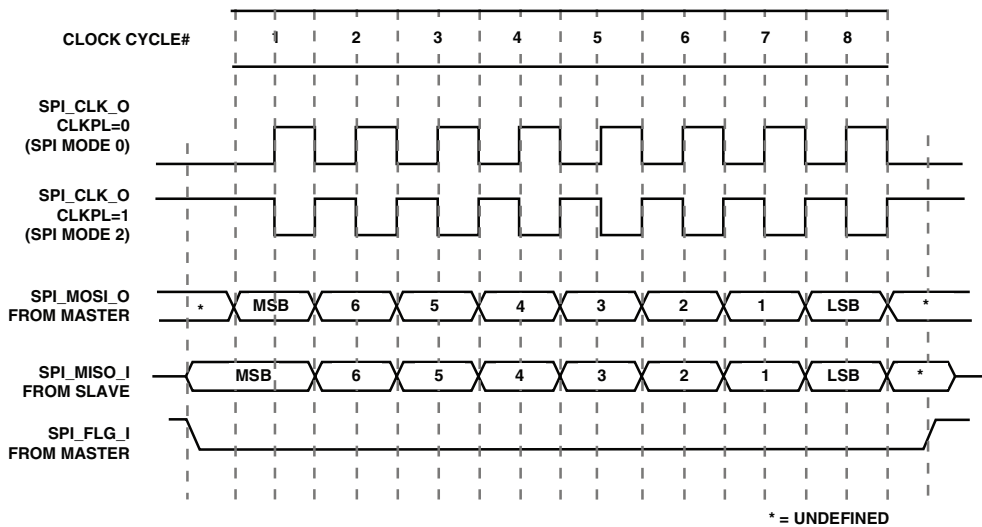

Figure 12-5. SPI Transfer Protocol for $CPHASE = 0$

Operating Modes

Figure 12-6 shows the SPI transfer protocol for $CPHASE = 1$. Note that SPI_{CLK} starts toggling at the beginning of the data transfer where the bit settings are $WL = 0$, and $MSBF = 1$.

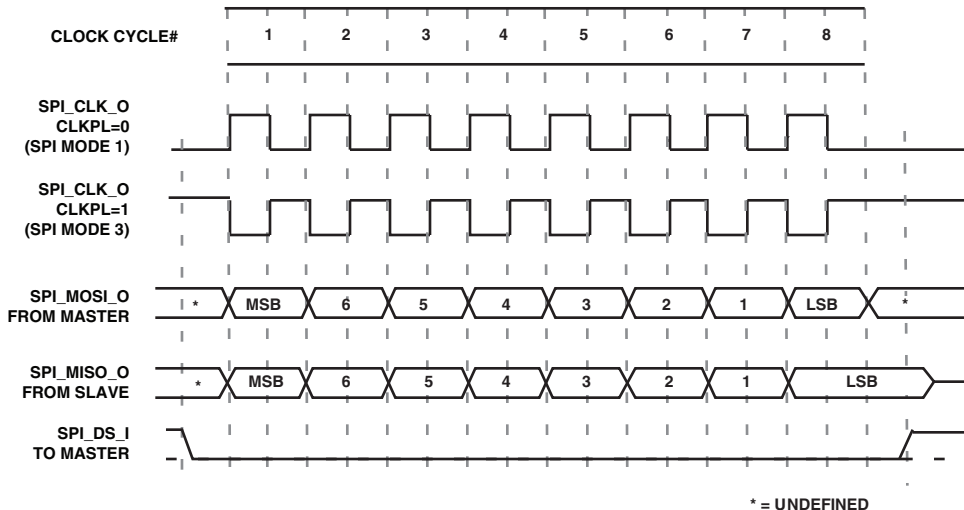

Figure 12-6. SPI Transfer Protocol for $CPHASE = 1$

Slave Select Outputs

If the SPI is enabled and configured as a master, any of the 14 DPI I/O pins may be used as slave-select outputs. For each DS_{xEN} bit which is set in the SPI_{FLG} register, the corresponding $SPI_{FLG}_{x_0}$ is configured as a slave-select output.

For example, if $DS_{1EN}=1$ is set, $SPI_{FLG}_{1_0}$ is driven as a slave-select. At the chip-level, $SPI_{FLG}_{1_0}$ can be connected to any of the DPI pins through SRU programming. For those DS_{xEN} bits which are not set, the corresponding $SPI_{x_0}_{FLG}_{x_{PBEN}_0}$ is driven low.

The behavior of the $SPI_{FLG}_{x_0}$ output depends on the value of the $CPHASE$ configuration bit. If $CPHASE=1$, all selected outputs may either remain

asserted (active-low) between transfers or be de-asserted between transfers. This is controlled in software using the SPIFLG_x bits (SPIFLG register). For example, to configure SPI_FLG1_0 as a slave-select, set DS1EN=1 and SPI_FLG1=1. As soon as this SPIFLG register write takes effect, the SPI_FLG1_0 (slave-select output pin) becomes active (low).

If needed, SPI_FLG_x_0 can be cycled high and low between transfers by setting the SPIFLG[_x] bit to 1 and back to 0. Otherwise, SPI_FLG_x_0 will remain active between transfers.

If CPHASE=0, all selected outputs are asserted only for the duration of the transfer. This is controlled by the internal SPI hardware. In this case, the SPIFLG_x bits are ignored. For example, to configure SPI_FLG1_0 as a slave-select, it is only necessary to set DS1EN=1.

Note that the SPI_FLG_x_0 signals behave as slave-select outputs only if the SPI module is enabled as a master. Otherwise, none of the bits in the SPIFLG register have any effect.

Frame Delay for Slave

When the processor is configured as an SPI slave, the SPI master must drive an SPICLK signal that conforms with [Figure 12-7](#). For exact timing parameters, please refer to the appropriate product data sheet.

As shown in [Figure 12-7](#), the SPI_DS_I lead time (T1), the SPI_DS_I lag time (T2), and the sequential transfer delay time (T3) must always be greater than or equal to one-half the SPICLK period. The minimum time between successive word transfers (T4) is two SPICLK periods. This time period is measured from the last active edge of SPICLK of one word to the first active edge of SPICLK of the next word. This calculation is independent from the configuration of the SPI (CPHASE, SPIMS, and so on).

Data Transfer

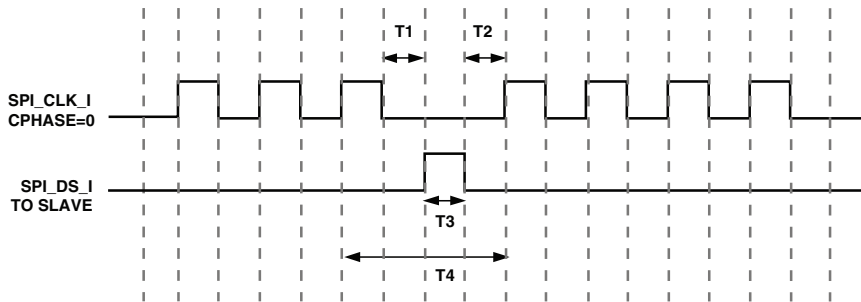

Figure 12-7. SPICLK Timing

This is shown as:

$$T3 = 0.5 \text{ SPI clock period}$$

$$T4 = 1.5 \text{ SPI clock period} + T3$$

For a master device with $CPHASE = 0$ or $CPHASE = 1$, this means that the slave-select output is inactive (high) for at least one-half the SPICLK period. In this case, T1 and T2 are each always be equal to one-half the SPICLK period.

Data Transfer

The SPI is capable of transferring data via the core and DMA. The following sections describe these transfer types.

Data Buffer

The SPI allows 3 different word lengths, which impacts the transmit or receive buffers with different packing methods.

8-bit word. The SPI port sends out only the lower eight bits of the word written to the SPI buffer. For example, when receiving, the SPI port packs the 8-bit word to the lower 32 bits of the RXSPI buffer while the upper bits in the registers are zeros. This code works only if the MSBF bit is zero in

both the transmitter and receiver, and the `SPICLK` frequency is small. If `MSBF = 1` in the transmitter and receiver, and `SPICLK` has a small frequency, the received words follow the order `0x12`, `0x34`, `0x56`, `0x78`.

16-bit word. When transmitting, the SPI port sends out only the lower 16 bits of the word written to the SPI buffer. When receiving, the SPI port packs the 16-bit word to the lower 32 bits of the `RXSPI` buffer while the upper bits in the register are zeros.

32-bit word. No packing of the `RXSPI` or `TXSPI` registers is necessary as the entire 32-bit register is used for the data word.

Core Transfers

For core-driven SPI transfers, the software has to read from or write to the `RXSPIx` and `TXSPIx` registers respectively to control the transfer. It is important to check the buffer status before reading from or writing to these registers because the core *does not* hang when it attempts to read from an empty buffer or write to a full buffer. When the core writes to a full buffer, the data that is in that buffer is overwritten and the SPI begins transmitting the new data. Invalid data is obtained when the core reads from an empty buffer.

For a master, when the transmit buffer becomes empty, or the receive buffer becomes full, the SPI device stalls the SPI clock until it reads all the data from the receive buffer or it detects that the transmit buffer contains a piece of data.

- When a master is configured with `TIMOD = 01` and the transmit buffer becomes empty, the SPI device stalls the SPI clock until a piece of data is written to the transmit buffer.
- When a master is configured with `TIMOD = 00` and the receive buffer becomes full, the SPI device stalls the SPI clock until all of the data is read from the receive buffer.

DMA Transfers

The SPI ports support both master and slave mode DMA. The following sections describe slave and master mode DMA operations, DMA chaining, switching between transmit and receive DMA operations, and processing DMA interrupt errors. Guidelines that programs should follow when performing DMA transfers over the SPI include:

- Do not write to the `TXSPIx` registers during an active SPI transmit DMA operation because DMA data will be overwritten.
- Similarly, do not read from the `RXSPIx` registers during active SPI DMA receive operations.
- Writes to the `TXSPIx` registers during an active SPI receive DMA operation are permitted. The `RXS` register is cleared when the `RXSPIx` registers are read.
- Reads from the `RXSPIx` registers are allowed at any time during transmit DMA.
- Interrupts are generated based on DMA events and are configured in the `SPIDMACx` registers.



To avoid data corruption, enable the SPI port before enabling DMA.

In order for a transmit DMA operation to begin, the transmit buffer must initially be empty (`TXS = 0`). While this is normally the case, this means that the `TXSPIx` registers should not be used for any purpose other than SPI transfers. For example, the `TXSPIx` registers should not be used as a scratch register for temporary data storage. Writing to the `TXSPIx` registers via the software sets the `TXS` bit.

-  For receive DMA in master mode the `SPICLK` stops only when the FIFO and `RXSPI` buffer is full (even if the DMA count is zero). Therefore, `SPICLK` runs for an additional five word transfers filling junk data in the FIFO and the `RXSPIx` buffers. This data must be cleared before a new DMA is initiated.

Slave DMA Transfer Preparation

When enabled as a slave, the device prepares for a new transfer according to the function and actions described in [Table 12-6](#).

The following steps illustrate the SPI receive or transmit DMA sequence in an SPI slave in response to a master command:

1. Once the slave-select input is active, the processor starts receiving and transmitting data on active `SPICLK` edges. The data for one channel (TX or RX) is automatically transferred from/to memory by the DMA controller. The function of the other channel is dependant on the `GM` and `SENDZ` bits in the `SPICTL` register.
2. Reception or transmission continues until the SPI DMA word count register transitions from 1 to 0.
3. A number of conditions can occur while the processor is configured for the slave mode:
 - If the DMA engine cannot keep up with the receive data stream during receive operations, the receive buffer operates according to the state of the `GM` bit in the `SPICTLx` registers.
 - If `GM = 0` and the DMA buffer is full, the incoming data is discarded, and the `RXSPIx` register is not updated. While performing a receive DMA, the transmit buffer is assumed to be empty. If `SENDZ = 1`, the device repeatedly transmits zeros on the `MISO` pin. If `SENDZ = 0`, it repeatedly transmits the contents of the `TXSPIx` registers.

Data Transfer

- If $GM = 1$ and the DMA buffer is full, the device continues to receive new data from the `MOSI` pin, overwriting the older data in the DMA buffer.
- If the DMA engine cannot keep up with the transmit data stream during a transmit operation because another DMA engine has been granted the bus (or for another reason), the transmit port operates according to the state of the `SENDZ` bit in the `SPICTLx` registers.

If `SENDZ = 1` and the DMA buffer is empty, the device repeatedly transmits zeros on the `MISO` pin. If `SENDZ = 0` and the DMA buffer is empty, it repeatedly transmits the last word transmitted before the DMA buffer became empty. All aspects of SPI receive operation should be ignored. The data in the `RXSPIx` registers is not intended to be used, and the `RXS` and `ROVF` bits should be ignored. The `ROVF` overrun condition cannot generate an error interrupt in this mode.



While a DMA transfer may be used on one channel (TX or RX), the core (based on the `RXS` and `TXS` status bits) can transfer data in the other direction.

SPI DMA Chaining

The serial peripheral interfaces support both single and chained DMA. However, unlike the serial ports, programs cannot insert a TCB in an active chain. [For more information, see “SPI TCB” on page 2-11.](#)

Setting Up and Starting Chained DMA

Configuring and starting chained DMA transfers over the SPI port is the same as for the serial port, with one exception. Contrary to SPORT DMA chaining, (where the first DMA in the chain is configured by the first TCB), for SPI DMA chaining, the first DMA is not initialized by a TCB. Instead, the first DMA in the chain must be loaded into the SPI parameter

registers (IISPI, IMSPI, CSPI, IISPIB, IMSPIB, CSPIB), and the chain pointer registers (CPSPI, CPSPIB) point to a TCB that describes the second DMA in the sequence.

 Writing an address to the CPSPI_x registers does not begin a chained DMA sequence unless the IISPI, IMSPI, CSPI, IISPIB, IMSPIB, and CSPIB registers are initialized, SPI DMA is enabled, the SPI port is enabled, and SPI DMA chaining is enabled.

Core and DMA Transfers

When the SPI DMA engine is configured for transmitting:

1. The receive interface cannot generate an interrupt, but the status can be polled.
2. The four-deep FIFO is not available in the receive path.

Similarly, when the SPI DMA engine is configured for receiving:

1. The transmit interface cannot generate an interrupt, but the status can be polled.
2. The four-deep FIFO is not available in the transmit path.

Changing SPI Configuration

Programs should take the following precautions when changing SPI configurations.

- The SPI configuration must not be changed during a data transfer.
- Change the clock polarity only when no slaves are selected.
- Change the SPI configuration when SPIEN = 0. For example, if operating as a master in a multislave system, and there are slaves that require different data or clock formats, then the master SPI should be disabled, reconfigured, and then re-enabled.

Data Transfer

However, when an SPI communication link consists of:

1. A single master and a single slave
2. $C_{PHASE} = 1$
3. The slave's slave select input is tied low

Then the program can change the SPI configuration. In this case, the slave is always selected. Data corruption can be avoided by enabling the slave only after configuring both the master and slave devices.

Starting and Stopping SPI Data Transfers

A SPI transfer's defined start and end depend on whether the device is configured as a master or a slave, whether C_{PHASE} mode is selected, and whether the transfer initiation mode is (T_{IMOD}) selected. For a master SPI with $C_{PHASE} = 0$, a transfer starts when either the TX_{SPI} register is written or the RX_{SPI} register is read, depending on the T_{IMOD} selection. At the start of the transfer, the enabled slave-select outputs are driven active (low). However, the $SPICLK$ starts toggling after a delay equal to one-half (0.5) the $SPICLK$ period. For a slave with $C_{PHASE} = 0$, the transfer starts as soon as the $SPIDS$ input transitions to low.

For $C_{PHASE} = 1$, a transfer starts with the first active edge of $SPICLK$ for both slave and master devices. For a master device, a transfer is considered complete after it sends and simultaneously receives the last data bit. A transfer for a slave device is complete after the last sampling edge of $SPICLK$.

The RXS bit defines when the receive buffer can be read. The TXS bit defines when the transmit buffer can be filled. The end of a single word transfer occurs when the RXS bit is set. This indicates that a new word has been received and latched into the receive buffer, RX_{SPI} . The RXS bit is set shortly after the last sampling edge of $SPICLK$. There is a 4 $PCLK$ cycle latency for a master/slave device, depending on synchronization. This is independent of C_{PHASE} , T_{IMOD} and the baud rate.

To maintain software compatibility with other SPI devices (HC-11), the SPI transfer finished bit (SPIF) is also available for polling. This bit may have slightly different behavior from that of other commercially available devices.

For a slave device, SPIF is set at the same time as RXS. For a master device, SPIF is set one-half (0.5) of the SPICLK period after the last SPICLK edge, regardless of CPHASE or CLKPL. The baud rate determines when the SPIF bit is set. In general, SPIF is set after RXS, but at the lowest baud rate settings (SPIBAUD < 4). The SPIF bit is set before the RXS bit, and consequently before new data has been latched into the RXSPI buffer. Therefore, for SPIBAUD = 2 or SPIBAUD = 3, the processor must wait for the RXS bit to be set (after SPIF is set) before reading the RXSPI buffer. For larger SPIBAUD settings (SPIBAUD > 4), RXS is set before SPIF.

Interrupts

The following section describes SPI operations using both the core and direct memory access (DMA). [Table 12-7](#) provides an overview of SPI interrupts.

Table 12-7. SPI Interrupt Overview

Interrupt Source	Interrupt Condition	Interrupt Completion	Interrupt Acknowledge	Default IVT
SPI (SPI Mode 3-0, 2 channels)	<ul style="list-style-type: none"> - DMA RX/TX done - Core RX buffer full - Core TX buffer empty - DMA multi master error - DMA under/overflow Error 	Internal transfer completion	RTI instruction	P1I, P18I

Interrupt Sources

The SPI ports can generate interrupts in five different situations. During core-driven transfers, an SPI interrupt is triggered:

1. When the TXSPI buffer has the capacity to accept another word from the core.
2. When the RXSPI buffer contains a valid word to be retrieved by the core.

The TIMOD (transfer initiation and interrupt) register determines whether the interrupt is based on the TXSPI or RXSPI buffer status.

 If configured to generate an interrupt when SPIRX is full (TIMOD = 00), the interrupt will be active 1 PCLK cycle after the RXS bit is set.

During DMA driven transfers, an SPI interrupt is triggered:

1. At the completion of a single DMA transfer.
2. At the completion of a number of DMA sequences (if DMA chaining is enabled).
3. When a DMA error has occurred.

Note that the SPIDMAC register must be initialized properly to enable DMA interrupts.

Each of these five interrupts are serviced using the interrupt associated with the module being used. The primary SPI uses the SPIHI interrupt and the secondary SPI uses the SPILI interrupt. Whenever an SPI interrupt occurs (regardless of the cause), the SPILI or SPIHI interrupts are latched. To service the primary SPI port, unmask (set = 1) the SPIHI bit (bit 12) in the IMASK register. To service the secondary SPI port, unmask (set = 1) the SPILIMSK bit (bit 19) in the LIRPTL register. For a list of these bits, see *SHARC Processor Programming Reference*.

When using DMA transfers, programs must also specify whether to generate interrupts based on transfer or error status. For DMA transfer status based interrupts, set the `INTEN` bit in the `SPIDMAC` register; otherwise, set the `INTERR` bit to trigger the interrupt if one of the error conditions occurs during the transmission like multimaster error (`MME`), transmit buffer underflow (`TUNF` – only if `SPIRCV = 0`), or receive buffer overflow (`ROVF` – only if `SPIRCV = 1`).

 During core-driven transfers, the `TUNF` and `ROVF` error conditions do not generate interrupts.

When DMA is disabled, the processor core may read from the `RXSPI` register or write to the `TXSPI` data buffer. The `RXSPI` and `TXSPI` buffers are memory-mapped IOP registers. A maskable interrupt is generated when the receive buffer is not empty or the transmit buffer is not full. The `TUNF` and `ROVF` error conditions do not generate interrupts in these modes.

Internal Transfer Completion

This mode resembles interrupt handling on previous SHARC processors. The DMA interrupts indicate DMA completion status and DMA error status. These interrupts are latched in the core when DMA count reaches zero.

For a chained DMA of blocks (`PCI = 1`), the interrupt is generated whenever the DMA count reaches zero.

Multi Master Error

The `SPIMME` bit (1) is set when the `SPI_DS_I` input pin of a device that is enabled as a master is driven low by some other device in the system. This occurs in multimaster systems when another device is also trying to be the master.

Debug Features

To enable this feature, set the `ISSEN` bit in the `SPICTL` register. As soon as this error is detected, the following actions are taken:

1. The `SPIMS` control bit in `SPICTL` is cleared, configuring the SPI interface as a slave.
2. The `SPIEN` control bit in `SPICTL` is cleared, disabling the SPI system.
3. The `SPIMME` status bit in `SPISTAT` is set.
4. An SPI interrupt is generated.

These four conditions persist until the `SPIMME` bit is cleared by a write 1-to-clear (W1C-type) software operation. Until the `SPIMME` bit is cleared, the SPI cannot be re-enabled, even as a slave. Hardware prevents the program from setting either `SPIEN` or `SPIMS` while `MME` is set.

When `SPIMME` is cleared, the interrupt is deactivated. Before attempting to re-enable the SPI as a master, the state of the `SPI_DS_I` input pin should be checked to ensure that it is high; otherwise, once `SPIEN` and `SPIMS` are set, another mode-fault error condition will immediately occur. The state of the input pin is reflected in the input slave select status bit (bit 7) in the `SPIFLG` register.

As a result of `SPIEN` and `SPIMS` being cleared, the SPI data and clock pin drivers (`MOSI`, `MISO`, and `SPICLK`) are disabled. However, the slave-select output pins revert to control by the processor flag I/O module registers. This may cause contention on the slave-select lines if these lines are still being driven by the processor.

Debug Features

The following sections provide information on features that help in debugging SPI software.

Shadow Receive Buffers

A pair of read-only (RO) shadow registers for the receive data buffers, `RXSPI` and `RXSPIB` are available for use in debugging software. These registers, `RXSPI_SHADOW` and `RXSPIB_SHADOW`, are located at different addresses from `RXSPI`, but their contents are identical to that of `RXSPI`. When `RXSPI` is read from core, the `RXS` bit is cleared (read only-to-clear) and an SPI transfer may be initiated (if `TIMOD = 00`). No such hardware action occurs when the shadow register is read. `RXSPI_SHADOW` is only accessible by the core.

Internal Loopback Mode

In this mode different types of loopback are possible since there is only one DMA channel available:

- Core receive and transmit transfers
- Transmit DMA and core receive transfers
- Core Transmit and DMA receive transfers

To loop data back from `MOSI` to `MISO`, the `MISO` pin is internally disconnected. The `MOSI` pin will contain the value being looped back. Programs should set the `SPIEN`, `SPIMS`, and `ILPBK` bits in the `SPICTLx` register.



Loopback operation is only used in master mode.

Loop Back Routing

The SPI supports an internal loop back mode using the SRU. [For more information, see “Loop Back Routing” on page 6-41.](#)

Effect Latency

The total effect latency is a combination of the write effect latency (core access) plus the peripheral effect latency (peripheral specific).

Write Effect Latency

For details on write effect latency, see *SHARC Processor Programming Reference*.

SPI Effect Latency

After the SPI registers are configured the effect latency is 2 PCLK cycles enable and 2 PCLK cycles disable.

Programming Model

The section describes which sequences of software steps are required to get the peripheral working successfully.

Master Mode Core Transfers

When the SPI is configured as a master, the SPI ports should be configured and transfers started using the following steps:

1. When `CPHASE` is set to 0, the slave-selects are automatically controlled by the SPI port. When `CPHASE = 1`, the slave-selects are controlled by the core, and the user software has to control the pins through the `SPIFLGx` bits. Before enabling the SPI port, programs should specify which of the slave-select signals to use, setting one or more of the required SPI flag select bits (`DSxEN`) in the `SPIFLGx` registers.

2. Write to the `SPICTLx` and `SPIBAUDx` registers, enabling the device as a master and configuring the SPI system by specifying the appropriate word length, transfer format, baud rate, and other necessary information.
3. If `CPHASE = 1` (user-controlled, slave-select signals), activate the desired slaves by clearing one or more of the SPI flag bits (`SPIFLGx`) in the `SPIFLGx` registers.
4. Initiate the SPI transfer. The trigger mechanism for starting the transfer is dependant upon the `TIMOD` bits in the `SPICTLx` registers. See [Table 12-6 on page 12-13](#) for details.
5. The SPI generates the programmed clock pulses on `SPICLK`. The data is shifted out of `MOSI` and shifted in from `MISO` simultaneously. Before starting to shift, the transmit shift register is loaded with the contents of the `TXSPIx` registers. At the end of the transfer, the contents of the receive shift register are loaded into the `RXSPIx` registers.
6. With each new transfer initiate command, the SPI continues to send and receive words, according to the SPI transfer mode (`TIMOD` bit in `SPICTLx` registers). See [Table 12-6 on page 12-13](#) for more details.

If the transmit buffer remains empty, or the receive buffer remains full, the device operates according to the states of the `SENDZ` and `GM` bits in the `SPICTLx` registers.

- If `SENDZ = 1` and the transmit buffer is empty, the device repeatedly transmits zeros on the `MOSI` pin. One word is transmitted for each new transfer initiate command.
- If `SENDZ = 0` and the transmit buffer is empty, the device repeatedly transmits the last word transmitted before the transmit buffer became empty.

Programming Model

- If $GM = 1$ and the receive buffer is full, the device continues to receive new data from the `MISO` pin, overwriting the older data in the `RXSPI` buffer.
- If $GM = 0$ and the receive buffer is full, the incoming data is discarded, and the `RXSPI` register is not updated.

Multimaster Transfers

The following steps show how to implement a system with two SPI devices. Since the slaves cannot initiate transfers over the bus, the master must send frames over the `MOSI` pin. This ensures that slaves can respond to the bus by sending messages over the `MISO` pin to the bus master.

1. Slave writes message to its `MISO` pin.
2. Slave starts polling its `SPI_DS_I` pin which is currently low.
3. Message is latched by current master and decoded.
4. Master de-asserts the slave select signal and clears the `SPIMS` bit to become a slave.
5. If bus requester detects the `SPIDS` pin high, it sets the `SPIMS` bit to get bus mastership.
6. The master selects a slave by driving its' slave select flag pin.

Slave Mode Core Transfers

When a device is enabled as a slave (and DMA mode is not selected), the start of a transfer is triggered by a transition of the `SPI_DS_I` select signal to the active state (low) or by the first active edge of the clock (`SPICLK`), depending on the state of `CPHASE`.

The following steps illustrate SPI operation in slave mode.

1. Write to the `SPICTLx` registers to make the mode of the serial link the same as the mode that is set up in the SPI master.
2. Write the data to be transmitted into the `TXSPIx` registers to prepare for the data transfer.
3. Once the `SPI_DS_I` signal's falling edge is detected, the slave starts sending and receiving data on active `SPICLK` edges.
4. The reception or transmission continues until `SPI_DS_I` is released or until the slave has received the proper number of clock cycles.
5. The slave device continues to receive or transmit with each new falling-edge transition on `SPI_DS_I` or active `SPICLK` clock edge.

If the transmit buffer remains empty, or the receive buffer remains full, the devices operate according to the states of the `SENDZ` and `GM` bits in the `SPICTLx` registers.

- If `SENDZ = 1` and the transmit buffer is empty, the device repeatedly transmits zero's on the `MISO` pin.
- If `SENDZ = 0` and the transmit buffer is empty, it repeatedly transmits the last word transmitted before the transmit buffer became empty.
- If `GM = 1` and the receive buffer is full, the device continues to receive new data from the `MOSI` pin, overwriting the older data in the `RXSPI` buffer.
- If `GM = 0` and the receive buffer is full, the incoming data is discarded, and the `RXSPIx` registers are not updated.

Master Mode DMA Transfers

To configure the SPI port for master mode DMA transfers:

1. To enable DPI pins as slave selects, programs should route them appropriately after the `SPICTLx` and `SPIBAUDx` registers are configured, but before enabling the DMA. When `CPHASE = 0`, the DPI pins are automatically activated by the SPI ports.
2. Enable the device as a master and configure the SPI system by selecting the appropriate word length, transfer format, baud rate, and so on in the `SPIBAUDx` and `SPICTLx` registers. The `TIMOD` field (bits 1–0) in the `SPICTLx` registers is configured to select transmit or receive with DMA mode (`TIMOD = 10`).
3. Activate the desired slaves by clearing one or more of the SPI flag bits (`SPIFLGx`) of the `SPIFLGx` registers, if `CPHASE = 1`.
4. For a single DMA, define the parameters of the DMA transfer by writing to the `IISPIx`, `IMSPIx`, and `CSPIx` registers. For DMA chaining, write the chain pointer address to the `CPSPIx` registers.

Write to the SPI DMA configuration registers, (`SPIDMACx`), to specify the DMA direction (`SPIRCV`, bit 1) and to enable the SPI DMA engine (`SPIDEN`, bit 0). If DMA chaining is desired, set (= 1) the `SPICHEN` bit (bit 4) in the `SPIDMACx` registers.

When enabled as a master, the DMA engine transmits or receives data as follows.

1. If the SPI system is configured for transmitting, the DMA engine reads data from memory into the SPI DMA FIFO. Data from the DMA FIFO is loaded into the `TXSPIx` registers and then into the transmit shift register. This initiates the transfer on the SPI port.

2. If configured to receive, data from the `RXSPIx` registers is automatically loaded into the SPI DMA FIFO. Then the DMA engine reads data from the SPI DMA FIFO and writes to memory. Finally, the SPI initiates the receive transfer.
3. The SPI generates the programmed signal pulses on `SPICLK` and the data is shifted out of `MOSI` and in from `MISO` simultaneously.
4. The SPI continues sending or receiving words until the SPI DMA word count register transitions from 1 to 0.

If the DMA engine is unable to keep up with the transmit stream during a transmit operation because the IOP requires the IOD (I/O data) bus to service another DMA channel (or for another reason), the `SPICLK` stalls until data is written into the `TXSPI` register. All aspects of SPI receive operation should be ignored. The data in the `RXSPI` register is not intended to be used, and the `RXS` (bits 28–27 and 31–30 in the `SPICTLx` registers) and `SPISTAT` bits (bits 26 and 29) should be ignored. The `ROVF` overrun condition cannot generate an error interrupt in this mode.

If the DMA engine cannot keep up with the receive data stream during receive operations, then `SPICLK` stalls until data is read from `RXSPI`. While performing a receive DMA, the processor core assumes the transmit buffer is empty. If `SENDZ = 1`, the device repeatedly transmits 0s. If `SENDZ = 0`, it repeatedly transmits the contents of the `TXSPI` register. The `TUNF` underrun condition cannot generate an error interrupt in this mode.

A master SPI DMA sequence may involve back-to-back transmission and/or reception of multiple chained DMA transfers. The SPI controller supports such a sequence with minimal processor core interaction.

Slave Mode DMA Transfers

A slave mode DMA transfer occurs when the SPI port is enabled and configured in slave mode, and DMA is enabled. When the `SPI_DS_I` signal

Programming Model

transitions to the active-low state or when the first active edge of `SPICLK` is detected, it triggers the start of a transfer.

When the SPI is configured for receive/transmit DMA, the number of words configured in the DMA count register should match the actual data transmitted. When the SPI DMA is used, the internal DMA request is generated for a DMA count of four. In case the count is less than four, one DMA request is generated for all the bytes. For example, when a DMA count of 16 is programmed, four DMA requests are generated (that is, four groups of four). For a DMA count of 18, five DMA requests are generated (four groups of four and one group of two). In case the SPI DMA is programmed with a value more than the actual data transmitted, some bytes may not be received by the SPI DMA due to the condition for generating the DMA request.

To configure for slave mode DMA:

1. Write to the `SPICTLx` register to make the mode of the serial link the same as the mode that is set up in the SPI master. Configure the `TIMOD` field to select transmit or receive DMA mode (`TIMOD = 10`).
2. Define DMA receive (or transmit) transfer parameters by writing to the `IISPIx`, `IMSPIx`, and `CSPIx` registers. For DMA chaining, write to the chain pointer address of the `CPSPIx` registers.
3. Write to the `SPIDMACx` registers to enable the SPI DMA engine and configure the following:
 - A receive access (`SPIRCV = 1`) or
 - A transmit access (`SPIRCV = 0`)
 - If DMA chaining is desired, set the `SPICHEN` bit in the `SPIDMACx` registers.



Enable the SPI port before enabling DMA to avoid data corruption.

Chained DMA Transfers

The sequence for setting up and starting a chained DMA is outlined in the following steps.

1. Clear the chain pointer register.
2. Configure the TCB associated with each DMA in the chain except for the first DMA in the chain.
3. Write the first three parameters for the initial DMA to the `IISPI`, `IMSPI`, `CSPI`, `IISPIB`, `IMSPIB`, and `CSPIB` registers directly.
4. Select a baud rate using the `SPIBAUD` register.
5. Route the DPI pins as slave selects and enable the corresponding bits in the `SPIFLGx` register.
6. Configure and enable the SPI port with the `SPICTL`, `SPICTLB` registers.
7. Configure the DMA settings for the entire sequence, enabling DMA and DMA chaining in the `SPIDMAC` register.

Begin the DMA by writing the address of a TCB (describing the second DMA in the chain) to the `CPSPI`, `CPSPI` registers.

Stopping Core Transfers

When performing transmit operations with the SPI port, disabling the SPI port prematurely can cause data corruption and/or not fully transmitted data. Before the program disables the SPI port in order to reconfigure it, the status bits should be polled to ensure that all valid data has been completely transferred. For core-driven transfers, data moves from the `TXSPI` buffer into a shift register. The following bits should be checked before disabling the SPI port:

Programming Model

1. Wait for the `TXSPIx` buffers to empty into the shift register. This is done when the `TXS` bit (bit 3) of the `SPISTATx` registers becomes zero.
2. Wait for the SPI shift registers to finish shifting out data. This is done when the `SPIF` bit (bit 0) of `SPISTATx` registers becomes one.
3. Disable the SPI ports by setting the `SPIEN` bit (bit 0) in the `SPICTLx` registers to zero.

Stopping DMA Transfers

When performing transmit DMA transfers, data moves through a four deep SPI DMA FIFO, then into the `TXSPIx` buffers, and finally into the shift register. DMA interrupts are latched when the I/O processor moves the last word from memory to the peripheral. For the SPI, this means that the SPI “DMA complete” interrupt is latched when there are six words remaining to be transmitted (four in the FIFO, one in the `TXSPIx` buffers, and one being shifted out of the shift register). To disable the SPI port after a DMA transmit operation, use the following steps:

1. Wait for the DMA FIFO to empty. This is done when the `SPIStx` bits (bits 13–12) in the `SPIDMACx` registers become zero.
2. Wait for the `TXSPIx` registers to empty. This is done when the `TXS` bit, (bit 3) in the `SPISTATx` registers becomes zero.

 When stopping receive DMA transfers, it is recommended that programs follow the SPI disable steps provided in [“Switching from Receive to Receive/Transmit DMA”](#) below.

3. Wait for the SPI shift register to finish transferring the last word. This is done when the `SPIF` bit (bit 0) of the `SPISTATx` registers becomes one.
4. Disable the SPI ports by setting the `SPIEN` bit (bit 0) of the `SPICTLx` registers to zero.

Switching from Transmit To Transmit/Receive DMA

The following sequence details the steps for switching from transmit to receive DMA.

With disabled SPI:

1. Clear the `SPICTLx` registers to disable SPI. Disabling the SPI also clears the `RXSPIx/TXSPIx` registers and the buffer status.
2. Clear the `SPIDMAXC` register.
3. Clear all errors by writing to the W1C-type bits in the `SPISTATx` registers. This ensures that no interrupts occur due to errors from a previous DMA operation.
4. Reconfigure the `SPICTLx` registers and enable the SPI ports.
5. Configure DMA by writing to the DMA parameter registers and enable DMA.

With enabled SPI:

1. Clear the `RXSPIx/TXSPxI` registers and the buffer status without disabling the SPI. This can be done by ORing `0xC0000` with the present value in the `SPICTLx` registers. For example, programs can use the `RXFLSH` and `TXFLSH` bits to clear `TXSPIx/RXSPIx` and the buffer status.
2. Clear the `SPIDMAC` register.
3. Clear all errors by writing to the W1C-type bits in the `SPISTAT` register. This ensures that no interrupts occur due to errors from a previous DMA operation.

Programming Model

4. Reconfigure the `SPICTL` register to remove the clear condition on the `TXSPI/RXSPI` registers.
5. Configure DMA by writing to the DMA parameter registers and enable DMA.

Switching from Receive to Receive/Transmit DMA

Use the following sequence to switch from receive to transmit DMA. Note that `TXSPIx` and `RXSPIx` are registers but they may not contain any bits, only address information.

With disabled SPI:

1. Clear the `SPICTLx` registers to disable SPI. Disabling SPI also clears the `RXSPIx/TXSPIx` register contents and the buffer status.
2. Disable DMA and clear the DMA FIFO by setting the `FIFOFLSH` bit in the `SPIDMACx` registers. This ensures that any data from a previous DMA operation is cleared because the `SPICLK` signal runs for five more word transfers even after the DMA count falls to zero in the receive DMA.
3. Clear all errors by writing to the `SPISTATx` registers. This ensures that no interrupts occur due to errors from a previous DMA operation.
4. Reconfigure the `SPICTLx` registers and enable SPI.
5. Configure DMA by writing to the DMA parameter registers and the `SPIDMACx` register.

With enabled SPI:

1. Clear the `RXSPIx/TXSPIx` registers and the buffer status without disabling the SPI by ORing `0xC0000` with the present value in the `SPICTLx` registers. Use the `RXFLSH` (bit 19) and `TXFLSH` (bit 18) bits in the `SPICTLx` registers to clear the `RXSPIx/TXSPIx` registers and the buffer status.
2. Disable DMA and clear the FIFO by the `FIFOFLSH` bit in the `SPIDMACx` registers. This ensures that any data from a previous DMA operation is cleared because `SPICLK` runs for five more word transfers even after the DMA count is zero in receive DMA.
3. Clear all errors by writing to the `WIC`-type bits in the `SPISTATx` registers. This ensures that no interrupts occur due to errors from a previous DMA operation.
4. Reconfigure the `SPICTLx` registers to remove the clear condition on the `TXSPIx/RXSPIx` registers.
5. Configure DMA by writing to the DMA parameter registers (described in [“Operating Modes” on page 2-25](#)) and the `SPIDMACx` registers using the `SPIDEN` bit (bit 0).

DMA Error Interrupts

The `SPIUNF` and `SPIOVF` bits of the `SPIDMACx` registers indicate transmission errors during a DMA operation in slave mode. When one of the bits is set, an SPI interrupt occurs. The following sequence details the steps to respond to this interrupt.

With disabling the SPI:

1. Disable the SPI port by writing `0x00` to the `SPICTLx` registers.
2. Disable DMA and clear the FIFO by setting the `FIFOFLSH` bit in the `SPIDMACx` registers. This ensures that any data from a previous DMA operation is cleared before configuring a new DMA operation.
3. Clear all errors by writing to the WIC-type bits in the `SPISTATx` registers. This ensures that the error bits `SPIOVF` and `SPIUNF` (in the `SPIDMACx` registers) are cleared when a new DMA is configured.
4. Reconfigure the `SPICTLx` registers and enable the SPI using the `SPIEN` bit.
5. Configure DMA by writing to the DMA parameter registers and the `SPIDMACx` registers.

Without disabling the SPI:

1. Disable DMA and clear the FIFO by setting the `FIFOFLSH` bit in the `SPIDMAC` register. This ensures that any data from a previous DMA operation is cleared before configuring a new DMA operation.
2. Clear the `RXSPIx/TXSPIx` registers and the buffer status without disabling SPI. This can be done by ORing `0xc0000` with the present value in the `SPICTLx` registers. Use the `RXFLSH` and `TXFLSH` bits to clear the `RXSPIx/TXSPIx` registers and the buffer status.

3. Clear all errors by writing to the W1C-type bits in the SPISTAT register. This ensures that error bits SPIOVF and SPIUNF in the SPIDMACx registers are cleared when a new DMA is configured.
4. Reconfigure the SPICTL register to remove the clear condition on the RXSPI/TXSPI register bits.
5. Configure DMA by writing to the DMA parameter registers and the SPIDMACx register.

Programming Model

13 PERIPHERAL TIMERS

In addition to the internal core timer, the processors contain identical 32-bit peripheral timers that can be used to interface with external devices. Each timer can be individually configured in three operation modes. The timers specifications are shown in [Table 13-1](#).

Table 13-1. Timer Specifications

Feature	Timer2-0
Connectivity	
Multiplexed Pinout	No
SRU2 DPI Required	Yes
SRU2 DPI Default Routing	Yes
Interrupt Control	Yes
Protocol	
Master Capable	Yes
Slave Capable	Yes
Transmission Simplex	N/A
Transmission Half Duplex	N/A
Transmission Full Duplex	N/A
Access Type	
Data Buffer	No
Core Data Access	N/A
DMA Data Access	N/A
DMA Channels	N/A

Features

Table 13-1. Timer Specifications (Cont'd)

Feature	Timer2-0
DMA Chaining	N/A
Boot Capable	N/A
Local Memory	No
Clock Operation	PCLK

Features

The peripheral timers have the features described below.

- Independent general-purpose timers.
- Three operation modes (PWM, Width Capture, External Watchdog).
- Global control/status registers for synchronous operation of multiple timers.
- Buffered timer registers (period and width) allow changes on the fly.



The core timer is controlled by system registers while the peripheral timers are controlled by memory-mapped registers.

Pin Descriptions

The timer has only one pin which acts as input or output based on the timer mode as shown in [Table 13-2](#).

Table 13-2. Peripheral Timer Pin Descriptions

Internal Node	Type	Description
TIMER2-0_I	I	Timer Signal. This input is active sampled during pulse width and period capture (width capture mode) or external event watchdog (external clock mode).
TIMER2-0_O	O	Timer Signal. This output is active driven in pulse width modulation (PWM out mode).
TIMER2-0_PBEN_O	O	Timer Pin Buffer Enable Output Signal. This output is only driven in PWM out mode.

SRU Programming

Since the timer has operation modes for input (capture and external clock mode) and output (PWM out mode), it requires bidirectional junctions. [Table 13-3](#) shows the required SRU routing.

Table 13-3. Timer DPI/SRU2 Signal Connections

Internal Node	DPI Group	SRU Register
Inputs		
TIMER2-0_I	Group A	SRU_INPUT2
Outputs		
TIMER2-0_O	Group B	
TIMER2-0_PBEN_O	Group C	

See also “[DPI Routing Capabilities](#)” on page 6-25.

Register Overview

This section provides brief descriptions of the major registers. For complete information see [“Peripheral Timer Registers” on page A-182](#).

Status and Control Registers (TMSTAT). Indicates the status of both timers using a single read. The TMSTAT register also contains timer enable bits. Within TMSTAT, each timer has a pair of sticky status bits, that require a write one-to-set (TIMxEN) or write one-to-clear (TIMxDIS) to enable and disable the timer respectively.

Counter Registers (TMxCNT). When disabled, the timer counter retains its state. When re-enabled, the timer counter is re initialized from the period/width registers based on configuration and mode. The timer counter value should not be set directly by the software. It can be set indirectly by initializing the period or width values in the appropriate mode. The counter should only be read when the respective timer is disabled. This prevents erroneous data from being returned.

Period Registers (TMxPRD). When enabled and running, the processor writes new values to the timer period and pulse width registers. The writes are buffered and do not update the registers until the end of the current period (when the timer counter register equals the timer period register).

During the *pulse width modulation* (PWM_OUT), the period value is written into the timer period registers. Both period and width register values must be updated “on the fly” since the period and width (duty cycle) change simultaneously. To insure the period and width value concurrency, a 32-bit period buffer and a 32-bit width buffer are used.

During the *pulse width and period capture* (WDTH_CAP) mode, the period values are captured at the appropriate time. Since both the period and width registers are read-only in this mode, the existing 32-bit period and width buffers are used.

During the *external event watchdog* (EXT_CLK) mode, the period register is write-only. Therefore, the period buffer is used in this mode to insure high/low period value coherency.

Pulse Width Register (TMxW). During the pulse width modulation (PWM_OUT), the width value is written into the timer width registers. Both width and period register values must be updated “on the fly” since the period and width (duty cycle) change simultaneously. To insure period and width value concurrency, a 32-bit period buffer and a 32-bit width buffer are used.

During the pulse width and period capture (WDTH_CAP) mode, both the period and width values are captured at the appropriate time. Since both the width and period registers are read-only in this mode, the existing 32-bit period and width buffers are used.

When the processor is in EXT_CLK mode, the width register is unused.

Read-Modify-Write

The traditional read-modify-write operation to enable/disable a peripheral is different for the timers. [For more information, see “Peripheral Timer Registers” on page A-182.](#)

Clocking

The fundamental timing clock of the peripheral timers is peripheral clock (PCLK).

Functional Description

Each timer has one dedicated bidirectional chip signal, $TIMER_x$. The two timer signals are connected to the 14 digital peripheral interface (DPI) pins through the signal routing unit (SRU). The timer signal functions as an output signal in PWM_OUT mode and as an input signal in WDTM_CAP and EXT_CLK modes (see “Operating Modes” on page 13-7). To provide these functions, each timer has four, 32-bit registers shown in Figure 13-1.

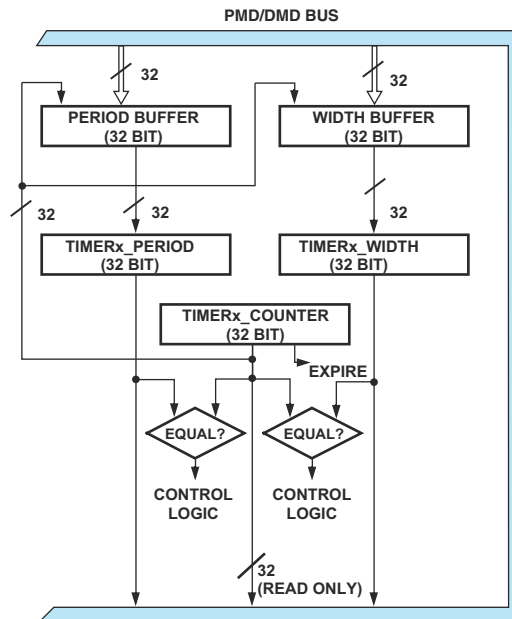

Figure 13-1. Timer Block Diagram

The registers for each timer are:

- Timer x control (TM_xCTL) register
- Timer x word count (TM_xCNT) register

- Timer x word period (TMxPRD) register
- Timer x word pulse width (TMxW) register

The timers also share a common status and control register—the timer global status and control (TMSTAT) register.

When clocked internally, the clock source is the processor’s peripheral clock (PCLK). The timer produces a waveform with a period equal to $2 \times \text{TMxPRD}$ and a width equal to $2 \times \text{TMxW}$. The period and width are set through the TMxPRD30-0 and the TMxW30-0 bits. Bit 31 is ignored for both.

Operating Modes

The three operation modes of the peripheral timer; PWM_OUT, WIDTH_CAP, and EXT_CLK, are described in [Table 13-4](#) and the following sections.

Table 13-4. Timer Signal Use

Register Settings	PWM_OUT Mode	WIDTH_CAP Mode	EXT_CLK Mode
MODE	01 = Output PWM Waveform	10 = Input Waveform	11 = Input Event
TIMEN	1 = Enable & Start Timer 0 = Disable Timer	1 = Enable & Start Timer 0 = Disable Timer	1 = Enable & Start Timer 0 = Disable Timer
PULSE	1 = Generate High Width 0 = Generate Low Width	1 = Measure High Width 0 = Measure Low Width	Count at event rise only
PRDCNT	1 = Generate PWM 0 = Single Width Pulse	1 = Measure Period 0 = Measure Width	Unused
IRQEN	1 = Enable Interrupt 0 = Disable Interrupt	1 = Enable Interrupt 0 = Disable Interrupt	1 = Enable Interrupt 0 = Disable Interrupt
Period	WO: Period Value	RO: Period Value	WO: Period Value
Width	WO: Width Value	RO: Width Value	Unused

Operating Modes

Table 13-4. Timer Signal Use (Cont'd)

Register Settings	PWM_OUT Mode	WIDTH_CAP Mode	EXT_CLK Mode
Counter	RO: Only if not enabled Counts down on PCLK	RO: Only if not enabled Counts up on PCLK	RO: Only if not enabled Counts down on Event
TIMxOVF (IRQ also set)	Set if Initialized with: Period < Width or Period == Width or Period == 0	Set if the Counter wraps (Error Condition)	Unused
TIMxIRQ (If enabled)	If PERIOD_CNT: 1 = Set at end of Period 0 = Set at end of Width	If PERIOD_CNT: 1 = Set at end of Period 0 = Set at end of Width	Set after Period Expires and PCLK is running

Pulse Width Modulation Mode (PWM_OUT)

In PWM_OUT mode, the timer supports on-the-fly updates of period and width values of the PWM waveform. The period and width values can be updated once every PWM waveform cycle, either within or across PWM cycle boundaries.

To enable PWM_OUT mode, set the TIMODE1-0 bits to 01 in the timer's configuration (TMxCTL) register. This configures the timer's TIMEx signal as an output with its polarity determined by PULSE as follows:

- If PULSE is set (= 1), an active high width pulse waveform is generated at the TIMEx signal.
- If PULSE is cleared (= 0), an active low width pulse waveform is generated at the TIMEx signal.

The timer is actively driven as long as the TIMODE field remains 01.

Figure 13-2 shows a flow diagram for PWM_OUT mode. When the timer becomes enabled, the timer checks the period and width values for plausibility (independent of the value set with the PRDCNT bit) and does *not* start to count when any of the following conditions are true:

- Width is equal to zero
- Period value is lower than width value
- Width is equal to period

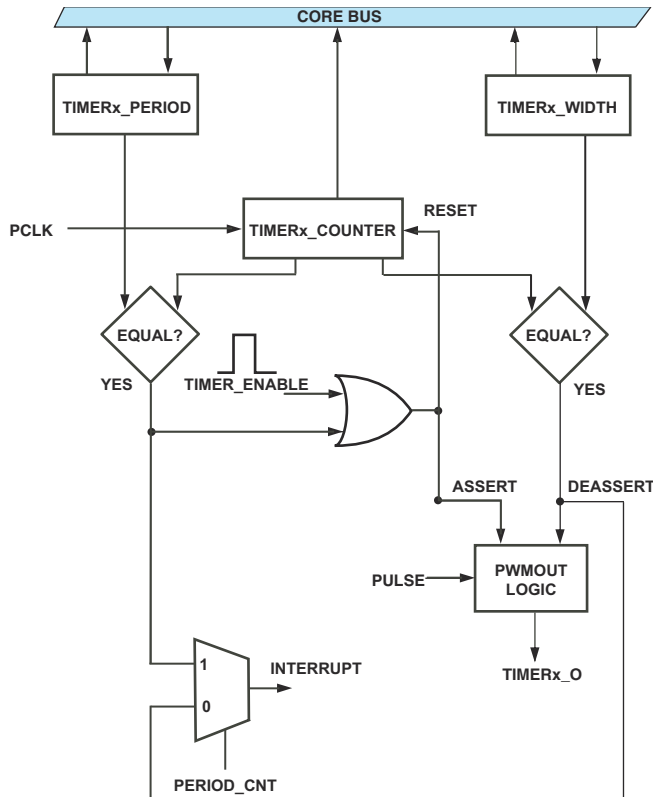

Figure 13-2. Timer Flow Diagram – PWM_OUT Mode

On invalid conditions, the timer sets both the `TIMxOVF` and the `TIMIRQx` bits and the Count register is not altered. Note that after reset, the timer registers are all zero. The PWM_OUT timing is shown in [Figure 13-3](#).

Operating Modes

As mentioned earlier, $2 \times TM \times PRD$ is the period of the PWM waveform and $2 \times TM \times W$ is the width. If the period and width values are valid after the timer is enabled, the count register is loaded with the value resulting from $0xFFFF\ FFFF - \text{width}$. The timer counts upward to $0xFFFF\ FFFF$. Instead of incrementing to $0xFFFF\ FFFF$, the timer then reloads the counter with the value derived from $0xFFFF\ FFFF - (\text{period} - \text{width})$ and repeats.

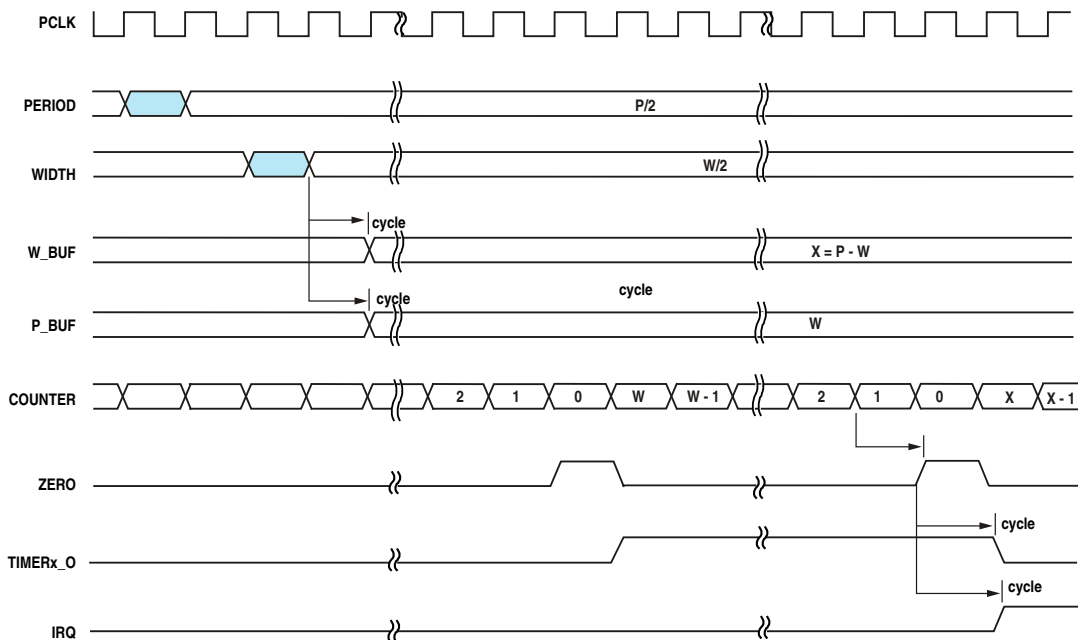

Figure 13-3. PWM_OUT Timing

PWM Waveform Generation

If the `PRDCNT` bit is set, the internally-clocked timer generates rectangular signals with well-defined period and duty cycles. This mode also generates periodic interrupts for real-time processing.

The 32-bit period ($TMxPRD$) and width ($TMxW$) registers are programmed with the values of the timer count period and pulse width modulated output pulse width.

When the timer is enabled in this mode, the $TIMERx$ signal is pulled to a deasserted state each time the pulse width expires, and the signal is asserted again when the period expires (or when the timer is started).

To control the assertion sense of the $TIMERx_0$ signal, the $PULSE$ bit in the corresponding $TMxCTL$ register is either cleared (causes a low assertion level) or set (causes a high assertion level).

When enabled, a timer interrupt is generated at the end of each period. An ISR must clear the interrupt latch bit $TIMxIRQ$ and might alter period and/or width values. In pulse width modulation applications, the program can update the period and pulse width values while the timer is running.

 When a program updates the timer configuration, the $TMxW$ register must always be written to last, even if it is necessary to update only one of the registers. When the $TMxW$ value is not subject to change, the ISR reads the current value of the $TMxW$ register and rewrite it again. On the next counter reload, all of the timer control registers are read by the timer.

To generate the maximum frequency on the $TIMERx_0$ output signal, set the period value to two and the pulse width to one. This makes the $TIMERx$ signal toggle every 2 $PCLK$ clock cycles as shown in [Figure 13-9](#). Assuming $PCLK = 133$ MHz:

$$\text{Maximum period} = 2 \times (2^{31} - 1) \times 7.5 \text{ ns} = 32 \text{ seconds.}$$

 If your application requires a more sophisticated PWM output generator, refer to [Chapter 5, Pulse Width Modulation](#).

Operating Modes

Single-Pulse Generation

If the `PRDCNT` bit is cleared, the `PWM_OUT` mode generates a single pulse on the `TIMERx_0` signal. This mode can also be used to implement a well defined software delay that is often required by state machines. The pulse width ($= 2 \times TMxW$) is defined by the width register and the period register should be set to a value greater than the pulse width register.

At the end of the pulse, the interrupt latch bit (`TIMxIRQ`) is set and the timer is stopped automatically. If the `PULSE` bit is set, an active high pulse is generated on the `TIMERx_0` signal. If the `PULSE` bit is not set, the pulse is active low.

Pulse Mode

The waveform produced in `PWM_OUT` mode with `PRDCNT = 1` normally has a fixed assertion time and a programmable deassertion time (via the `TMxW` register). When both timers are running synchronously by the same period settings, the pulses are aligned to the asserting edge as shown in [Figure 13-4](#). Note that the timer does not support toggling of the `PULSE` bit in each period.

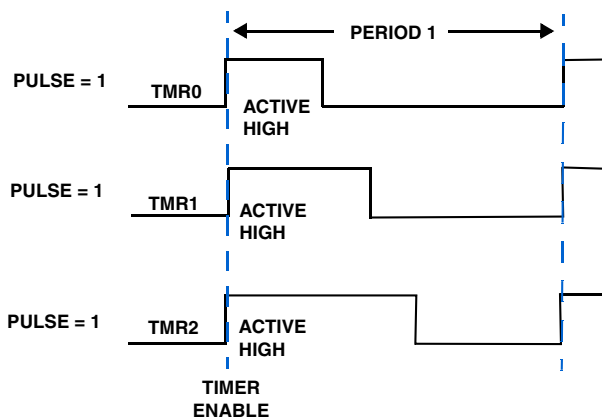

Figure 13-4. Timers with Pulses Aligned to Asserting Edge

Pulse Width Count and Capture Mode (WDTH_CAP)

To enable WDTH_CAP mode, set the `TIMODE1-0` bits in the `TMxCTL` register to 10. This configures the `TIMERx` signal as an input signal with its polarity determined by `PULSE`. If `PULSE` is set (= 1), an active high width pulse waveform is measured at the `TIMER_Ix` signal. If `PULSE` is cleared (= 0), an active low width pulse waveform is measured at the `TIMERx_I` signal. The internally-clocked timer is used to determine the period and pulse width of externally-applied rectangular waveforms. The period and width registers are read-only in WDTH_CAP mode. The period and pulse width measurements are with respect to a clock frequency of $PCLK \div 2$.

Figure 13-5 shows a flow diagram for WDTH_CAP mode. In this mode, the timer resets words of the count in the `TMxCNT` register value to `0x0000 0001` and does not start counting until it detects the leading edge on the `TIMERx_I` signal.

When the timer detects a first leading edge, it starts incrementing. When it detects the trailing edge of a waveform, the timer captures the current value of the count register ($= TMxCNT \div 2$) and transfers it into the `TMxW` width registers. At the next leading edge, the timer transfers the current value of the count register ($= TMxCNT \div 2$) into the `TMxPRD` period register. The count registers are reset to `0x0000 0001` again, and the timer continues counting until it is either disabled or the count value reaches `0xFFFF FFFF`.

In this mode, programs can measure both the pulse width and the pulse period of a waveform. To control the definition of the leading edge and trailing edge of the `TIMERx_I` signal, the `PULSE` bit in the `TMxCTL` register is set or cleared. If the `PULSE` bit is cleared, the measurement is initiated by a falling edge, the count register is captured to the `WIDTH` register on the rising edge, and the period register is captured on the next falling edge.

The `PRDCNT` bit in the `TMxCTL` register controls whether an enabled interrupt is generated when the pulse width or pulse period is captured. If the `PRDCNT` bit is set, the interrupt latch bit (`TIMxIRO`) gets set when the pulse

Operating Modes

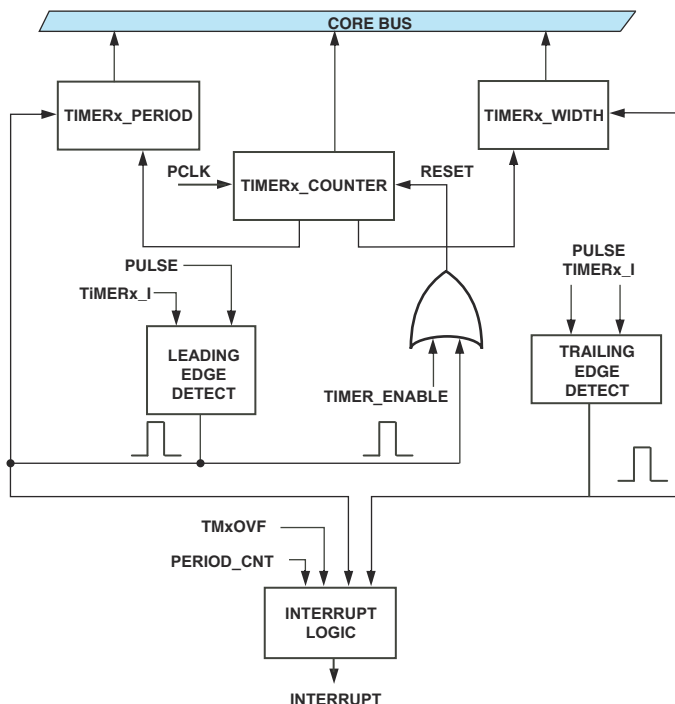

Figure 13-5. Timer Flow Diagram – WIDTH_CAP Mode

period value is captured. If the `PRDCNT` bit is cleared, the `TIMxIRQ` bit gets set when the pulse width value is captured.

If the `PRDCNT` bit is cleared, the first period value has not yet been measured when the first interrupt is generated. Therefore, the period value is not valid. If the interrupt service routine reads the period value anyway, the timer returns a period value of zero. When the period expires, the period value is loaded in the `TMxPRD` register. The `WIDTH_CAP` timing is shown in [Figure 13-6](#).

The first width value captured in `WIDTH_CAP` mode is erroneous due to synchronizer latency. To avoid this error, programs must issue two `NOP` instructions between setting `WIDTH_CAP` mode and setting `TIMxEN`.

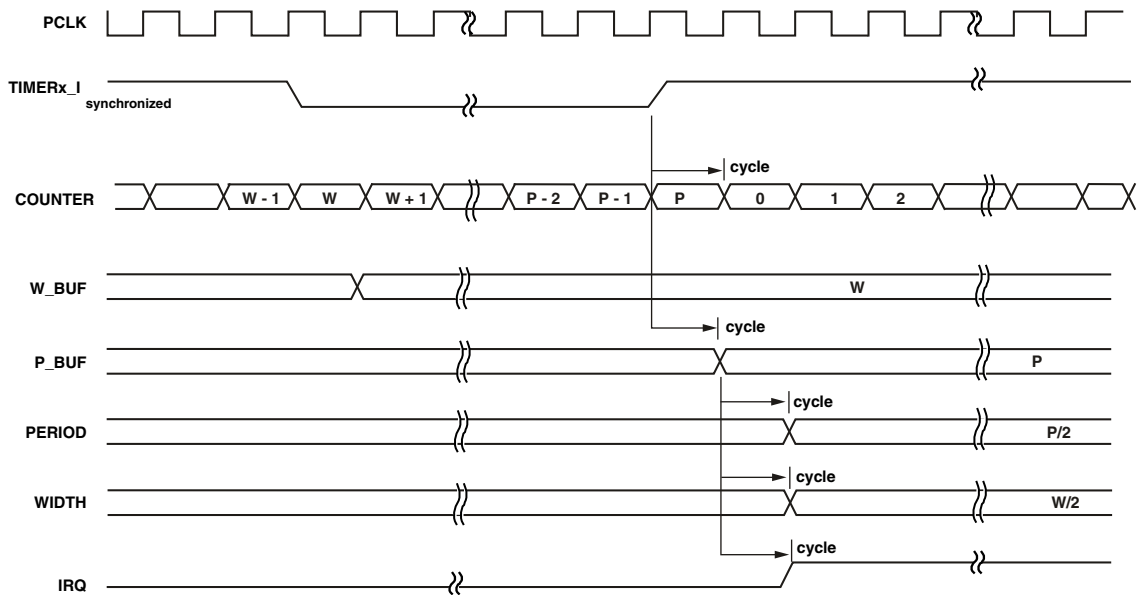

Figure 13-6. WDTI_CAP Timing (Period Count = 1)

External Event Watchdog Mode (EXT_CLK)

Figure 13-7 shows a flow diagram for EXT_CLK mode. To enable EXT_CLK mode, set the `TIMODE1-0` bits in the `TMxCTL` register to 11 in the `TMxCTL` register. This samples the `TIMERx_I` signal as an input. Therefore, in EXT_CLK mode, the `TMxCNT` register should not be read when the counter is running.

The operation of the EXT_CLK mode is as follows:

Operating Modes

1. Program the $TIMxPRD$ period register with the value of the maximum timer external count.
2. Set the $TIMxEN$ bits. This loads the period value in the count register and starts the countdown.
3. When the period expires, an interrupt, ($TIMxIRQ$) occurs.

After the timer is enabled, it waits for the first rising edge on the $TIMERx_I$ signal. The rising edge forces the count register to be loaded by the value $(0xFFFF\ FFFF - TIMxPRD)$. Every subsequent rising edge increments the count register. After reaching the count value $0xFFFF\ FFFE$, the $TIMxIRQ$ bit is set and an interrupt is generated. The next rising edge reloads the count register with $(0xFFFF\ FFFF - TIMxPRD)$ again.

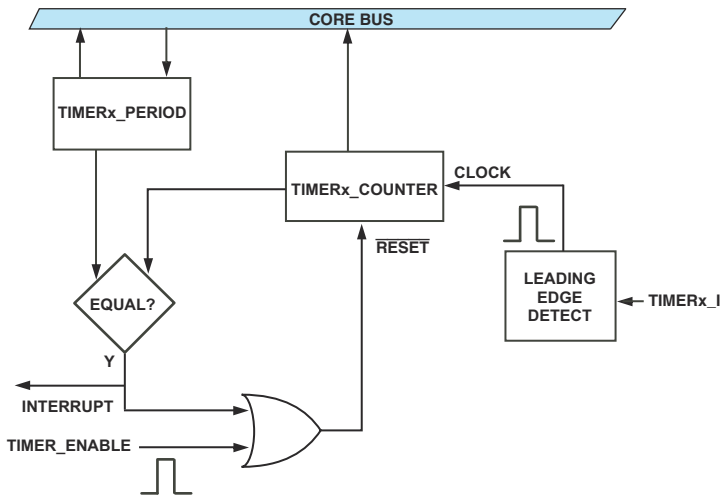

Figure 13-7. Flow Diagram EXT_CLK Mode

i For EXT_CLK mode only, setting the **PULSE** bit to 1 or 0 does not have any effect on the edge in which the count happens. It is always clocked at the rising edge.

The EXT_CLK timing is shown in [Figure 13-8](#).

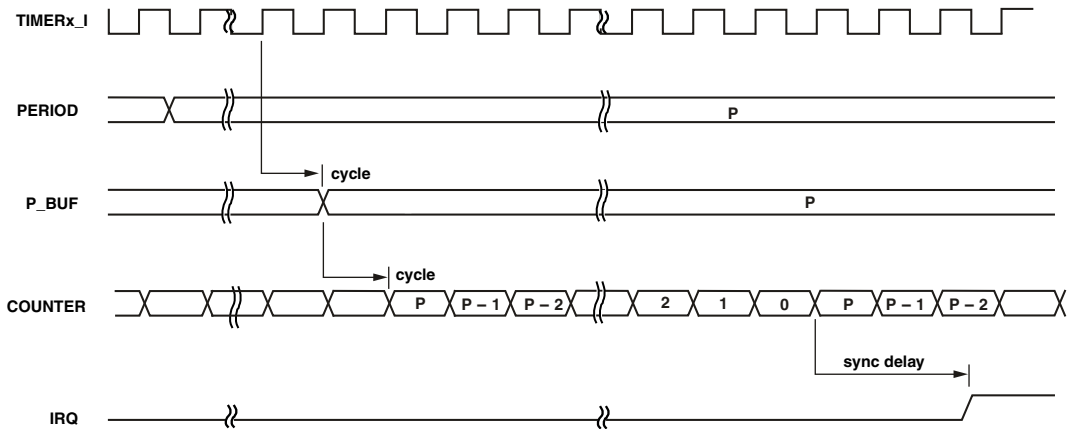

Figure 13-8. EXT_CLK Timing

The configuration bit, `PRDCNT`, has no effect in this mode. Also, `TIMxOVF` is never set and the width register is unused.

Interrupts

This section describes all relevant registers and hardware to raise and service interrupts. [Table 13-5](#) provides an overview of timer interrupts.

Table 13-5. Timer Interrupt Overview

Interrupt Source	Interrupt Condition	Interrupt Completion	Interrupt Acknowledge	Default IVT
GP Timer (PWM, Width Capture, Ext Watchdog, 3 channels)	<ul style="list-style-type: none"> – Timer expire – Timer overflow 		W1C (Write 1-to-clear) TMxSTAT + RTI instruction	P2I, P10I, P17I

Interrupts

Sources

Each timer generates a unique interrupt request signal. A common register latches these interrupts so that a program can determine the interrupt source without reference to the timer's interrupt signal. The `TMSTAT` register contains an interrupt latch bit (`TIMxIRQ`) and an overflow/error indicator bit (`TIMxOVF`) for each timer.

A timer overflow error interrupt (if enabled) is also generated if the count register reaches a value of `0xFFFF FFFF`. At that point, the timer is disabled automatically, and the `TIMxOVF` status bit is set, indicating a count overflow. The `TIMxIRQ` and `TIMxOVF` bits are sticky bits, and programs must explicitly clear them.

These sticky bits are set by the timer hardware and may be watched by software. They need to be cleared in the `TMSTAT` register by software explicitly. To clear, write a one to the corresponding bit in the `TMSTAT` register as shown in [Listing 13-1](#).

Listing 13-1. Clearing Sticky Bits

```
TMRO_ISR:
ustat2=TIM0IRQ;
dm(TMOSTAT)=ustat2;    /* W1C the Timer0 bit */
r10=dm(TMOCTL);       /* dummy read for write latency */
instructions;
instructions;
RTI;
```

 Interrupt and overflow bits may be cleared simultaneously with timer enable or disable.

To enable a timer's interrupt, set the `IRQEN` bit in the timer's configuration (`TMxCTL`) register and unmask the timer's interrupt by setting the corresponding bit of the `IMASK` register. With the `IRQEN` bit cleared, the timer does not set its interrupt latch (`TIMxIRQ`) bits. To poll the `TIMxIRQ` bits

without generating a timer interrupt, programs can set the `IRQEN` bit while leaving the timer's interrupt masked.

With interrupts enabled, ensure that the interrupt service routine (ISR) clears the `TIMxIRQ` latch before the `RTI` instruction to assure that the interrupt is not serviced erroneously. In external clock (`EXT_CLK`) mode, the latch should be reset at the very beginning of the interrupt routine so as not to miss any timer event.

Watchdog Functionality

Any of the timers can be used to implement a watchdog functionality that can be controlled by either an internal or an external clock source.

For a program to service the watchdog, the program must reset the timer value by disabling and then re-enabling the timer. Servicing the watchdog periodically prevents the count register from reaching the period value and prevents the timer interrupt from being generated. When the timer reaches the period value and generates the interrupt, reset the processor within the corresponding watchdog's ISR.

Debug Features

The following section provides information on debugging features available with the timer.

Loop Back Routing

The timer support an internal loop back mode by using the SRU. [For more information, see “Loop Back Routing” on page 6-41.](#)

Emulation Considerations

An emulation halt will not stop the timer period counter.

Effect Latency

The total effect latency is a combination of the write effect latency (core access) plus the peripheral effect latency (peripheral specific).

Write Effect Latency

For details on write effect latency, see *SHARC Processor Programming Reference*.

Peripheral Timers Effect Latency

After the timer registers are configured the effect latency is 3 PCLK cycles enable and 2 PCLK cycles disable. The timer starts 3 PCLK cycles after the TIMEN bit is set.

When the timer is enabled, the count register is loaded according to the operation mode specified in the TMxCTL register. When the timer is disabled, the counter registers retain their state; when the timer is re-enabled, the counter is reinitialized based on the operating mode ([Figure 13-9](#)). The program should never write the counter value directly.

Programming Model

The section describes which sequences of software steps are required to get the peripheral working successfully.

To enable an individual timer, set the timer's TIMxEN bit in the TMSTAT register. To disable an individual timer, set the timer's TIMxDIS bit in the TMSTAT register. To enable both timers in parallel, set all the TIMxEN bits in the TMSTAT register.

Before enabling a timer, always program the corresponding timer's configuration (TMxCTL) register. This register defines the timer's operating mode,

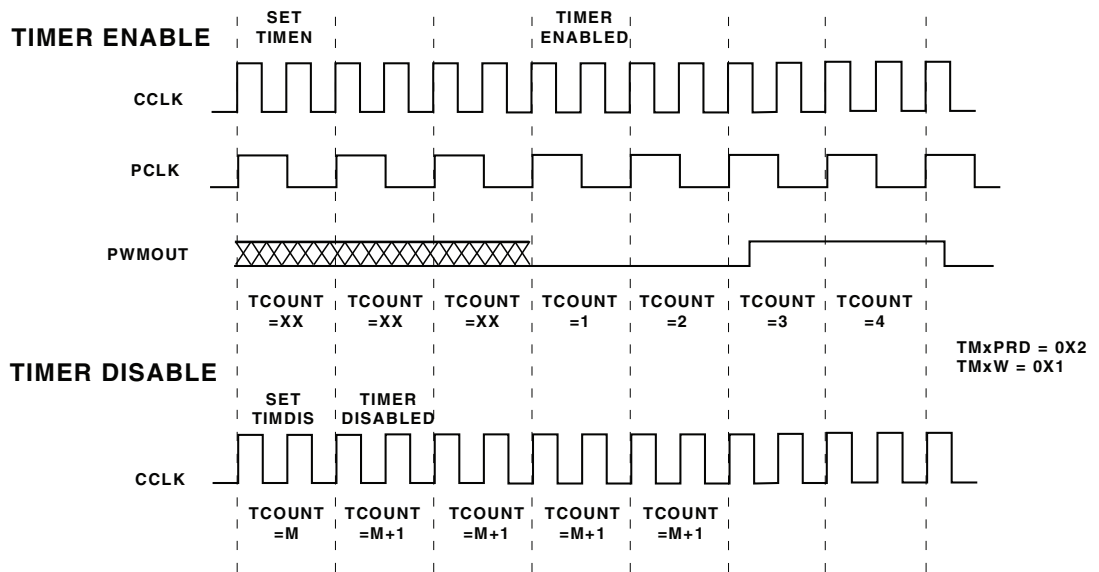

Figure 13-9. Timer PWM Enable and Disable Timing

the polarity of the `TIMERx` signal, and the timer's interrupt behavior. Do not alter the operating mode while the timer is running. For more information, see “Control Registers (TMxCTL)” on page A-183.

PWM Out Mode

Use the following procedure to configure and run the timer in PWM out mode.

1. Reset the `TIMEN` bit and set the configuration mode to 01 to select `PWM_OUT` operation. This configures the `TIMERx_0` pin as an output pin with its polarity determined by the `PULSE` bit.
 - Outputs a positive active pulse width at the `TIMERx_0` pin.
 - Outputs a negative active pulse width at the `TIMERx_0` pin.

Programming Model

2. Initialize the period register values.
3. Initialize the width register value. Insure that the period value is greater than the width value.
4. Set the `TIMEN` bit. The timer performs boundary exception checks on the period and width values:
 - If (`width == 0` or `Period < width` or `period == width`) both the `OVF_ERR` and `TRQ` bits are set.
 - If there are no exceptions, the width value is loaded into the counter and it starts counting.

The timer produces PWM waveform with a period of $2 \times \text{period}$ and a width of $2 \times \text{width}$.

- When $2 \times \text{width}$ expires, the counter is loaded with $2x(\text{period} - \text{width})$ and continues counting.
- When $2 \times \text{period}$ expires, the counter is loaded with $2 \times \text{width}$ value again and the cycle repeats.
- When the width or period expires, the `TRQ` bit (if enabled) is set depending on the `PRDCNT` bit.
- When `TRQ` is sensed, read the status register (`TMxSTAT`) and perform the appropriate “write-one” to clear.

WDTH_CAP Mode

Use the following procedure to configure and run the timer in WDTH_CAP out mode.

1. Reset the `TIMEN` bit and set the configuration mode to 10 to select WDTH_CAP operation. This configures the `TIMERx_I` pin as an input pin with its polarity determined by the `PULSE` bit.
 - Measures a positive active pulse width at the `TIMERx_I` pin.
 - Measures a negative active pulse width at the `TIMERx_I` pin.
2. The `PRDCNT` bit determines when the \overline{TRQ} status bit (if enabled) is set.
 - If (`PRDCNT == 1`), \overline{TRQ} is set when the period expires and the value is captured.
 - If (`PRDCNT == 0`), \overline{TRQ} is set when the width expires and the value is captured.
3. Valid period and width values are set in their respective registers when \overline{TRQ} is set.

The period and width values are measured with respect to `PCLK`. This makes this mode coherent with the `PWM_OUT` mode, where the output waveforms have a period of 2 x period and a width of 2 x width.

Note that the first period value will not have been measured when the first width is measured, so it is not valid. The timer sets and returns a period value of zero in this case. When the period expires, the period value is placed into the period register. When \overline{TRQ} is sensed, read the status and perform the appropriate “write-one” to clear.

EXT_CLK Mode

Use the following procedure to configure and run the timer in EXT_CLK out mode.

1. Reset the `TIMEN` bit and set the configuration mode to 11 to select EXT_CLK operation.

This configures the `TIMERx_I` pin as an input pin regardless of the setting of the `PULSE` bit. Note that the timer always samples the rising edge in this mode. The period register is `WO` and the width register is unused in this mode.

2. Initialize the period register with the value of the maximum external count.
3. Set the `TIMEN` bit. This loads the period value in the counter and starts the count down.

When the period expires, it is reloaded with the period value and the cycle repeats. Counter counts with each edge of the input waveform, asynchronous to `PCLK`.

When the period expires, \overline{TRQ} (if enabled) is set and `TMR_IRQ` is asserted. An external clock can trigger the Timer to issue an interrupt and wake up an idle processor.

Reads of the count register are not supported in EXT_CLK mode.

14 UART PORT CONTROLLER

The universal asynchronous receiver/transmitter (UART) is a full-duplex peripheral compatible with the PC-style, industry-standard UART. The interface specifications are shown in [Table 14-1](#).

Table 14-1. UART Specifications

Feature	UART1-0
Connectivity	
Multiplexed Pinout	No
SRU DAI Required	No
SRU DAI Default Routing	N/A
SRU2 DPI Required	Yes
SRU2 DPI Default Routing	Yes
Interrupt Control	Yes
Protocol	
Master Capable	Yes
Slave Capable	Yes
Transmission Simplex	Yes
Transmission Half Duplex	Yes
Transmission Full Duplex	Yes
Access Type	
Data Buffer	Yes
Core Data Access	Yes
DMA Data Access	Yes

Features

Table 14-1. UART Specifications (Cont'd)

Feature	UART1-0
DMA Channels	4
DMA Chaining	Yes
Boot Capable	No
Local Memory	No
Clock Operation	PCLK/16

Features

The UART converts data between serial and parallel formats. The serial format follows an asynchronous protocol that supports various word lengths, stop bits, and parity generation options. The UART includes interrupt handling hardware. Interrupts can be generated from 12 different events. [Figure 14-1 on page 14-7](#) shows the functional block.

- Compatible with the RS-232 and RS-485 Standards
- Data packing support for efficient memory usage
- Full duplex DMA operation
- Multiprocessor communication using 9 bit addressing
- Autobaud detection support

The UARTs do not support MODEM functionality.

SRU Programming

The SRU (signal routing unit) needs to be programmed in order to connect the UART signals to the output pins or connect the output of the transmitter to the receiver. The UART signals need to be routed as shown in [Table 14-2](#).

Table 14-2. UART Pin Descriptions

Internal Node	DPI Group	SRU Register
Input		
UART1-0_RX_I	Group A	SRU2_INPUT0
Outputs		
UART1-0_TX_O	Group A, B	
UART1-0_TX_PBEN_O	Group C	

Register Overview

The processor provides a set of PC-style, industry-standard control and status registers for the UART. These memory-mapped IOP registers are byte-wide registers that are mapped as half-words with the most significant byte zero-filled.

Line Control Register (UARTxLCR). Controls format of the data character frames. It selects word length, number of stop bits and parity.

Divisor Latch High/Low Register (UARTxDLL, UARTxDLLH). Characterize the UART bit rate. The divisor is split into the divisor latch low byte (UARTxDLL) and the divisor latch high byte (UARTxDLH).

Mode Control Register (UARTxMODE). Controls packing and address modes.

Clocking

Transmit Buffer Control Register (UARTxTXCTL). Controls core or DMA operation.

Receive Buffer Control Register (UARTxRXCTL). Controls core or DMA operation.

Interrupt Enable Control Register. Enables interrupt requests from system handling.

Line Status Register (UARTxLSR). Returns status of controls format of the data character frames as overrun or framing errors and break interrupts.

Transmit Status Register (UARTxTXSTAT). Returns status of core or DMA operations.

Receive Status Register (UARTxRXSTAT). Returns status of core or DMA operations.

Interrupt Identification Status Register (UARTxIIR). The register is used to get the status of all interrupts into one channel.

Clocking

The fundamental timing clock of the UART module is peripheral clock/16 (PCLK/16).

The bit rate is characterized by the peripheral clock (PCLK) and the 16-bit divisor. The divisor is split into the UART divisor latch low byte register (UARTxDLL) and the UART divisor latch high byte register (UARTxDLH).

These registers form a 16-bit divisor. The baud clock is divided by 16 so that:

- Divisor = 1 when $UARTxDLL = 1$ $UARTxDLH = 0$
- Divisor = 65,535 when $UARTxDLL = UARTxDLH = FF$
- UART Baud rate = $PCLK / (16 \times \text{divisor})$, where $PCLK$ is the system clock frequency and the divisor can be a value from 1 to 65,536



The 16-bit divisor formed by the $UARTxDLH$ and $UARTxDLL$ registers resets to 0x0001, resulting in the highest possible clock frequency by default. If the UART is not used, disabling the UART clock saves power (see bits 13 and 14 in the “[Power Management Control Registers \(PMCTL\)](#)” on page A-7). The $UARTxDLH$ and $UARTxDLL$ registers can be programmed by software before or after turning on the clock.

[Table 14-3](#) provides example divide factors required to support most standard baud rates.

Table 14-3. UART Baud Rate Examples With 100 MHz PCLK

Baud Rate	Divisor Latch (DL)	Actual	% Error
2400	2604	2400.15	0.006
4800	1302	4800.31	0.007
9600	651	9600.61	0.006
19200	326	19,171.78	0.147
38400	163	38,343.56	0.147
57600	109	57,339.45	0.452
115200	54	115,740.74	0.469
921,600	7	892,857.14	3.119
6,250,000	1	6,250,000	–

Functional Description



Careful selection of PCLK frequencies, that is, even multiples of desired baud rates, can result in lower error percentages.

Functional Description

The UART supports multiprocessor communication using 9-bit address detection. This allows the units to be used in multi-drop networks using the RS-485 data interface standard. The UART has its own set of control and status registers ([Figure 14-1](#)).

The UART is a DMA-capable peripheral with support for separate transmit and receive DMA master channels. It can be used in either DMA or core modes of operation. The core mode requires software management of the data flow using either interrupts or polling. The DMA method requires minimal software intervention as the DMA engine itself moves the data. [For more information, see “DMA Transfers” on page 14-14.](#)

Either one of the peripheral timers can be used to provide a hardware-assisted autobaud detection mechanism for use with the UART. See the [“Autobaud Detection” on page 14-22.](#)

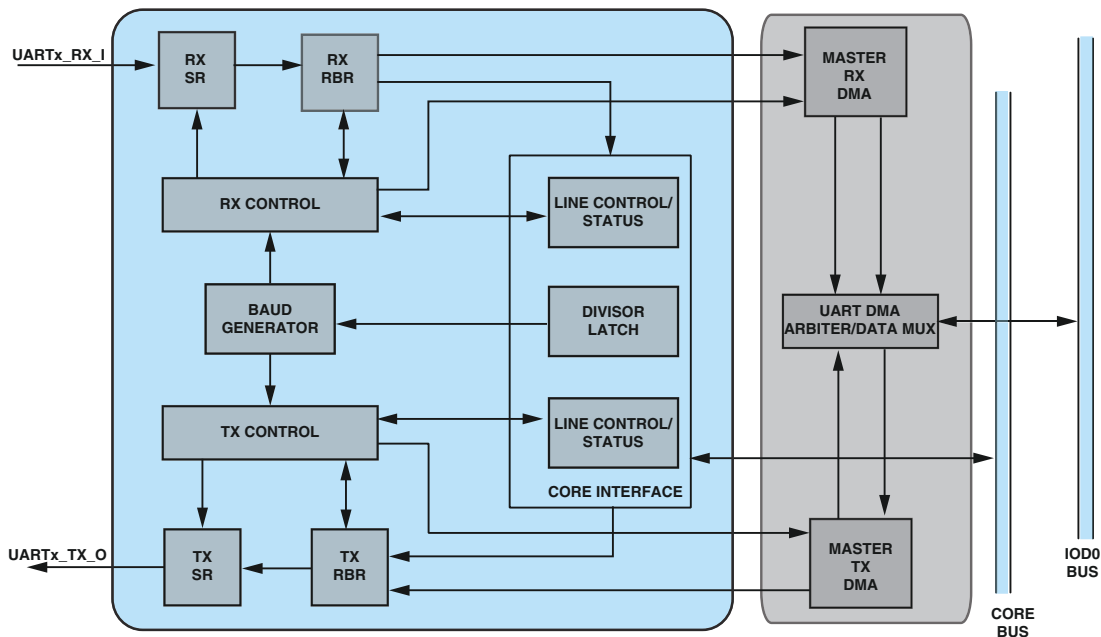

Figure 14-1. UART Functional Block Diagram

Serial Communication

The UART follows an asynchronous serial communication protocol with these options:

- 5 – 8 data bits
- 1 or 2 stop bits
- None, even, or odd parity

All data words require a start bit and at least one stop bit. With the optional parity bit, this creates a 7 to 12-bit range for each word. The format of received and transmitted character frames is controlled by the line control register (`UARTxLCR`). Data is always transmitted and received least significant bit (LSB) first.

Operating Modes

Figure 14-2 shows a typical physical bit stream measured on the transmit pin.

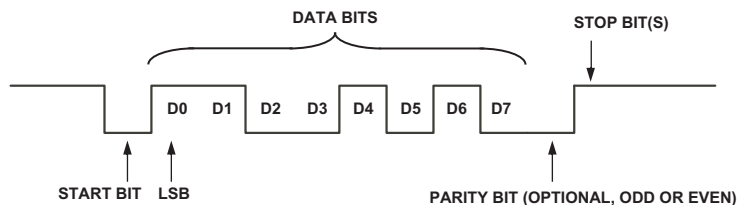

Figure 14-2. Bit Stream on the Transmit Pin

Transmit and receive channels are both buffered. The `UARTxTHR` register buffers the transmit shift register (`UARTxTSR`) and the `UARTxRBR` register buffers the receive shift register (`UARTxRSR`). The shift registers are not directly accessible by software.

Operating Modes

The two UART operation modes are described in the following sections.

Data Packing

The UART provides packed and unpacked modes of data transfer to and from the internal memory of the processors. This mode is set using the `UARTPACK` bit (bit 0) in the `UARTxMODE` register. In unpacked mode, the data word is appended to the left with 24 zeros during transmission or reception. In packed mode, two words of data are transmitted or received with their corresponding higher bytes filled with zeros. For example, consecutive data words `0xAB` and `0xCD` are packed as `0x00CD 00AB` in the receiver, and `0x00CD 00AB` is transmitted as two words of `0xAB` and `0xCD` successively from the transmitter. Packing is available in both I/O and DMA modes. A control bit, `UARTPKSYN`, can be used to re synchronize

the packing. For information on using the UART for DMA transfers, see “DMA Transfers” on page 14-14.

 The packed feature is provided to use the internal memory of the processor in a more efficient manner.

Note that in packed mode, both the transmitter and receiver operate with an even number of words. A transmit-buffer-empty or receive-buffer-full interrupt is generated only after an even number of words are transferred.

 Programs must use care when using the packing feature in 9-bit mode.

9-Bit Transmission Mode

To select 9-bit transmission mode in the transmitter, set the TX9 bit in the UART_MODE register and the UAEN bit in the UARTx_TXCTL register (to enable transmission). The 9-bit data (TX9D) can be directly written to the UART_THR buffer – either in packed or unpacked format. The UART transmitter transmits the TX9D bit instead of the parity bit. During 9-bit transmission mode, the parity select controls and the word length select do not have any effect.

For the receiver, set the RX9 bit in the UART_MODE register and the UAEN bit in the UAC_RXCTL register (to enable reception). Set the address enable bit (UARTAEN) to enable address detection.

If the received ninth bit is high, the received word is shifted from the RSR register to the UART_RBR buffer which generates an interrupt. Read the UART_RBR buffer to find out if the device is being addressed. If the device is being addressed, the address enable (UARTAEN bit) is cleared to allow data and address bytes to be read into the receive buffer.

During the 9-bit transmission mode parity has to be calculated in software to detect errors. The reception may be stopped when the receiver receives another address which is different from its own.

Data Transfer

In 9-bit mode, the address detect interrupt can be generated whenever the receiver gets an address word, irrespective of the packing mode. This helps programs respond to an address word immediately. The program is expected to take into account these features when using packed mode.

Packed Mode



Programs must use care when using the packing feature in 9-bit transmission mode.

- Programs should write the `UARTPKSYN` bit (bit 1) with a 1 each time an address is received. This starts the reception of the following data from the lower half-word of the `UARTxRBR` register.
- The address-detect interrupt is generated whenever the UART receiver receives an address, irrespective of the packing. The DR bit in the `UARTxLSR` register can be used to discover whether the address is in the lower ($DR = 0$) or higher half-word ($DR = 1$). The LSR register must be read before reading the `UARTxRBR` register, because the latter clears the DR bit. Reading the `UARTxRBR` register clears both the address-detect and the data-ready interrupts. In non-packed mode, when the address-detect interrupt is generated, it means that the data is ready in the RBR buffer while in packed mode, this is not the case.

Data Transfer

The UART is capable of transferring data using both the core and DMA. Not that data packing is available using both data transfer types. [For more information, see “Data Packing” on page 14-8.](#)

Data Buffers

The UART contains a single data buffer register for transmission and reception. These buffers are described in the following sections.

Transmit Holding Registers (UARTxTHR)

A write to the UART transmit holding register (UARTxTHR) initiates the transmit operation. The data is moved to the internal transmit shift register (UARTxTSR) where it is shifted out at a baud rate equal to $PCLK/(16 \times \text{Divisor})$ with start, stop, and parity bits appended as required. All data words begin with a 1-to-0 transition start bit. The transfer of data from the UARTxTHR register to the transmit shift register sets the transmit holding register empty status flag (UARTTHRE) in the UART line status register (UARTxLSR).

This 32-bit write only register uses only 18-bits. The other bits are filled with zeros during writes. In no-pack mode (default), only the lower byte is used—all other bits are zero filled. However in pack mode, both the high and low bytes are used (Figure 14-3). The TX9Dx bits are the ninth bit in 9-bit transmission mode. A write to the UART transmit holding register (UARTxTHR) initiates the transmit operation and reads from this address return the UARTxRBR register.

Data Transfer

Note that data is transmitted and received by the least significant bit (LSB) first (bit 0) followed by the most significant bits (MSBs).

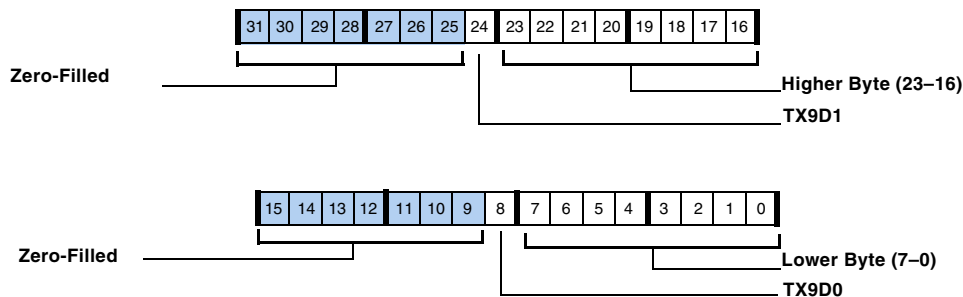

Figure 14-3. UART Transmit Holding Register (Packing Enabled)

Receive Buffer Registers (UARTxRBR)

The receive operation uses the same data format as the transmit configuration, except that the number of stop bits is always assumed to be 1. After detection of the start bit, the received word is shifted into the receive shift register (UARTxRSR) at a baud rate of $PCLK/(16 \times \text{Divisor})$. After the appropriate number of bits (including stop bit) is received, the data and any status are updated and the UARTxRSR register is transferred to the UART receive buffer register (UARTxRBR), shown in Figure 14-4. After the transfer of the received word to the UARTxRBR buffer and the appropriate synchronization delay, the data ready status flag (UARTDR) is updated.

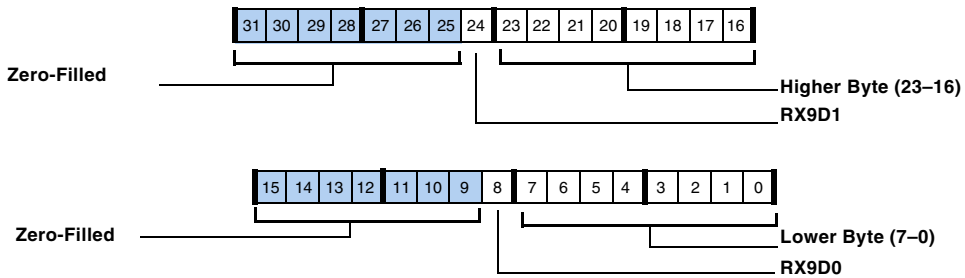

Figure 14-4. UART Receive Buffer Register

A sampling clock equal to 16 times the baud rate samples the data as close to the midpoint of the bit as possible. Because the internal sample clock may not exactly match the asynchronous receive data rate, the sampling point drifts from the center of each bit. The sampling point is synchronized again with each start bit, so the error accumulates only over the length of a single word. A receive filter removes spurious pulses of less than two times the sampling clock period.

i Because of the destructive nature of reading this register, a shadow register is provided for reading the contents of the corresponding main register. [For more information, see “Debug Features” on page 14-21.](#)

Core Transfers

Core transfers move data to and from the UART by the processor core. To transmit a character, load it into the `UARTxTHR` register. Received data can be read from the `UARTxRBR` register. The processor must write and read one character at time.

To prevent any loss of data and misalignments of the serial data stream, the UART line status register (`UARTxLSR`) provides two status flags for handshaking—`UARTTHRE` and `UARTDR`.

Data Transfer

The `UARTTHRE` flag is set when the `UARTxTHR` register is ready for new data and cleared when the processor loads new data into the `UARTxTHR` register. Writing this register when it is not empty overwrites the register with the new value and the previous character is never transmitted.

The `UARTDR` flag signals when new data is available in the `UARTxRBR` register. This flag is cleared automatically when the processor reads from this register. Reading the `UARTxRBR` register when it is not full returns the previously received value. When the `UARTxRBR` register is not read in time, newly received data overwrites the `UARTxRBR` register and the overrun (`UARTOE`) flag is set.

With interrupts disabled, these status flags can be polled to determine when data is ready to move. Note that because polling can be processor-intensive, it is not typically used in real-time signal processing environments.

DMA Transfers

The UART interface support both standard and chained DMA. However, unlike the serial ports, programs cannot insert a TCB in an active chain using the UART.

In the UART, separate receive and transmit DMA channels move data between the UART and memory. The software does not have to move data, it just has to set up the appropriate transfers either through normal DMA or DMA chaining. Software can write up to two words into the `UARTxTHR` register before enabling the UART clock. As soon as the UART DMA engine is enabled, those two words are sent. See also [“Functional Description” on page 2-17](#).

To perform DMA transfers, the UART has a special set of receive and transmit registers. These registers are listed in [“Standard DMA Parameter Registers” on page 2-4](#).

No additional buffering is provided in the UART DMA channel, so the latency requirements are the same as core transfers. However, the latency is determined by the bus activity and arbitration mechanism and not by the processor loading and interrupt priorities.

DMA through the UART is started by setting up values in the DMA parameter registers and then writing to the transmit and receive control registers, enabling the module using the `UARTEN` bits (in the `UARTxTXCTL` and `UARTxRXCTL` registers) and enabling DMA using the `UARTDEN` bits. A DMA can be interrupted by resetting the `UARTDEN` bit in the control register. A DMA request that is already in the pipeline completes normally.

DMA Chaining

DMA chaining is enabled by setting the `UARTCHEN` bit in the transmit and receive control registers. When chaining is enabled at the end of a current DMA, the next set of DMA parameters are loaded from internal memory and a new DMA starts. The index of the memory location is written in the chain pointer register. DMA parameter values reside in consecutive memory locations as shown in [Table 2-14 on page 2-12](#). Chaining ends when the chain pointer register contains address `0x00000` for the next parameter block.

Interrupts

The following sections provide information on the UART and interrupt generation. [Table 14-4](#) provides an overview of UART interrupts.

-  If UART core interrupts (core RX INT of UART) are routed via the DPI interrupt, programs do not need to read the `DPI_IRPTL` register for interrupt acknowledge. Reading the `UARTxIIR` register also clears the `DPI_IRPTL` register.

Interrupts

Table 14-4. UART Interrupt Overview

Interrupt Source	Interrupt Condition	Interrupt Completion	Interrupt Acknowledge	Default IVT
DPI UART (TX/RX)	<ul style="list-style-type: none">– DMA RX/TX done– Core RX buffer full– Core TX buffer empty– Core RX Error (overrun, parity, framing, break)– DMA RX Error (overrun, parity, framing)– Core/DMA 9-bit addressing	Internal transfer completion	For UART DMA: Read to clear DPI_IRPTL + RTI instruction For UART core (RX INT): Read to clear UARTxIIR + RTI instruction	P14I
UART (TX/RX)	<ul style="list-style-type: none">– DMA RX/TX done– Core RX buffer full– Core TX buffer empty– Core RX Error (overrun, parity, framing, break)– DMA RX Error (overrun, parity, framing)– Core/DMA 9-bit addressing	Internal transfer completion	For UART DMA: RTI instruction For UART core (RX INT): Read to clear UARTxIIR + RTI instruction	Need to route UARTxTXI UARTxRXI (PICRx) to any PxxI

Interrupt Routing

The following sections describe the various possibilities for routing a UART interrupt to the interrupt vector table (IVT).

DPI

The UART interrupts are all combined into the digital peripheral interface (DPI) interrupt. The `DPI_IRPTL` register determines whether an interrupt is for the transmitter or receiver. [Listing 14-1](#) shows an example of how to enable the UART over the DPI.

Listing 14-1. Enabling DPI UART Interrupts

```

bit set mode1 IRPTEN;           /* enables global interrupts */
bit set imask P1I;             /* unmask P1I interrupt */
ustat1=dm(PICR0);             /* route UART0_RXI 0x13 to P1I */
bit set ustat1 P1I4|P1I1|P1I0;
bit clr ustat1 P1I3|P1I2;
dm(PICR0)=ustat1;

```

UART

The UART receive and transmit interrupts can also be programmed through the peripheral interrupt control registers (PICRx) as separate interrupts. (By default, these interrupts are not configured in the IRPTL register—the PICRx register has to be programmed to configure them.) This method shown in [Listing 14-2](#) uses the PICR register with the code value of the UARTx_RXI or UARTx_TXI interrupts.

Listing 14-2. Enabling UART Interrupts

```

bit set mode1 IRPTEN;           /* enables global interrupts */
bit set imask P1I;             /* unmask P1I interrupt */
ustat1=dm(PICR0);             /* route UART0_RXI 0x13 to P1I */
bit set ustat1 P1I4|P1I1|P1I0;
bit clr ustat1 P1I3|P1I2;
dm(PICR0)=ustat1;

```

The following sections provide information on all of the available interrupt sources.

DMA Interrupts

With system DMA enabled, the UART uses DMA to transfer data to or from the processor. Dedicated DMA channels are available for receive and transmit operations. Line error handling can be configured completely independently from the receive/transmit setup.

Interrupts

For DMA, the transmit interrupt is generated when a DMA in transmit mode is complete whereas the receive interrupt is generated when a receive DMA is complete or when a receive error occurs. The `UART_RXSTAT` register reports whether the interrupt is due to DMA completion or errors.

For information on using the UART for DMA transfers, see [“DMA Transfers” on page 14-14](#), [“Interrupts” on page 6-32](#), and [Appendix B, Peripheral Interrupt Control](#).

Core Interrupts

The UART has two interrupt outputs referred to as the UART RX and UART TX interrupts. This is somewhat misleading in that in core mode all interrupts are grouped together as a single interrupt (`UART_RX`).

 Even though the UART has two interrupts for receive and transmit, in core mode, all interrupts are grouped as a single receive interrupt (`UART_RXI`) only.

The UART interrupt enable register (`UARTxIER`) is used to enable requests for core system handling of empty or full states of UART data registers. Unless polling is used as a means of action, the `UARTBIE` and/or `UARTTBEIE` bits in this register are normally set.

Setting the bits of this register in core mode enables the UART to interrupt the processor for each word of data. For proper operation in this mode, system interrupts must be enabled, and appropriate interrupt handling routines must be present. For backward compatibility, the `UARTxIIR` register still reflects the correct interrupt status. The transmit interrupt request is cleared by writing new data to the `UARTxTHR` register or by reading the `UARTxIIR` register.

 When the `UARTTBEIE` bit is set in the `UARTxIER` register for core transfers, the UART module immediately issues an interrupt.

When initiating the transmission of a string, no special handling of the first character is required. Set the `UARTTBEIE` bit (bit 1) and let the interrupt service routine (ISR) load the first character from memory and write it to the `UARTxTHR` register in the normal manner. Accordingly, the `UARTTBEIE` bit should be cleared if the string transmission has completed.

Alternatively, UART writes and reads can be accomplished by ISRs. Separate interrupt lines are provided for the transmit, receive, and error signals. The independent interrupts can be enabled individually by the `UARTxIER` register.

For legacy reasons, the UART interrupt identification register (`UARTxIIR`) still reflects the UART interrupt status (see [Table 14-4](#)). Legacy operation may require bundling all UART interrupt sources to a single interrupt channel and servicing them all by the same software routine. This can be established by globally assigning all UART interrupts to the same interrupt priority using the programmable interrupt priority control registers.

Please note the special role of the `UARTxIIR` register read in the case where the service routine does not want to transmit further data. If software stops transmission, it must read the `UARTxIIR` register to reset the interrupt request. As long as the `UARTxIIR` register reads `0x04` or `0x06` (indicating that another interrupt of higher priority is pending), the `UARTxTHR` empty latch cannot be cleared by reading the `UARTxIIR` register.



The following restrictions should be noted.

1. If either the line status interrupt or the receive data interrupt has been assigned a lower interrupt priority by the interrupt controller, a deadlock condition can occur. To avoid this, always assign the lowest priority of the enabled UART interrupts to the `UARTxTHR` empty event.
2. Because of the destructive nature of reading the `UARTxIIR` register, a shadow register (`UARTxIIRSH`) is provided for reading the contents of the corresponding main register.

Interrupts

Error Interrupts

The `UARTLSIE` bit (bit 2) enables interrupt generation on an independent interrupt channel when any of the following conditions are raised by the respective bit in the UART line status register (`UARTxLSR`):

- Receive overrun error (`UARTOE`)
- Receive parity error (`UARTPE`)
- Receive framing error (`UARTFE`)
- Break interrupt (`UARTBI`)

In core transfers, the receive interrupt is generated for the following cases.

- When `UARTxRBR` is full
- On a receive overrun error
- On a receive parity error
- On a receive framing error
- On a break interrupt (`RXSIN` held low)
- When `UARTxTHR` is empty
- An address detect (`UARTADI`) interrupt (for 9-bit mode)
- A transmit complete (`UARTTXFI`) interrupt

The ISRs can evaluate the status bit field within the UART interrupt identification register (`UARTxIIR`) to determine the signalling interrupt source. If more than one source is signalling, the status field displays the one with the highest priority. Interrupts also must be assigned and unmasked by the processor's interrupt controller. The ISRs must clear the interrupt latches explicitly.

Debug Features

The following sections describe the debug features of the UART port controller.

Shadow Registers

Because of the destructive nature of reading the following registers: interrupt identification (UARTxIIR), line status (UARTxLSR) and read buffer (UARTxRBR) shadow registers are provided for reading the contents of the corresponding main registers. The shadow registers, (UARTxIIRSH), (UARTxLSRSH) and (UARTxRBRSH) return exactly the same contents as the main register, but without changing the register's status in any way.

Shadow Buffer

Because of the destructive nature of reading the read buffer (UARTxRBR) a shadow buffer is provided. The shadow buffer (UARTxRBRSH) returns exactly the same contents as the main buffer, but without changing the register's status in any way.

Loop Back Routing

The UART supports an internal loop back mode by using the SRU. [For more information, see “Loop Back Routing” on page 6-41.](#)

Effect Latency

The total effect latency is a combination of the write effect latency (core access) plus the peripheral effect latency (peripheral specific).

Programming Model

Write Effect Latency

For details on write effect latency, see *SHARC Processor Programming Reference*.

UART Effect Latency

After the UART registers are configured the effect latency is 2 PCLK cycles.

Note that when transmitting data the effective data on DPI pins can't be seen immediately after 2 PCLK cycles because the time which the UART takes to start driving data depends on the baud rate settings.

Programming Model

The following sections provide some programming procedures for core and DMA data transfers.

Autobaud Detection

When the baud rate of the incoming signal is not known, one of the general-purpose timers can be used in width capture mode to automatically calculate the baud rate. Do not enable the UART until the width is captured by the timer. To perform autobaud detection, use the following procedure.

1. The UART RX input signal is fed to a DPI pin buffer. This buffer is used as an input (DPI_PBEN $_{xx}$ _I is low). The pin buffer output (DPI_PB $_{xx}$ _0) is routed to both inputs UART $_{x}$ _RX_I and TIMER $_{x}$ _I.
2. Configure the timer in width capture mode with the timer interrupt enabled. Inside the ISR, the program should read the width of the incoming signal and disable the timer.

3. Send test data through the host device that can be used for calculating the baud rate of the incoming signal. A NULL character (0x00) can be used for this purpose.
4. The baud rate can be derived from the width of timer as follows:
$$\text{BAUDR} = \text{Width} \div (8 \times (\text{number of zero data bits} + 1))$$
5. When using a NULL character, the number of zero data bits is 8. Programs can also send some other pattern for this purpose. Once the baud rate is calculated inside the timer ISR, the UART can be programmed with the calculated baud rate.

Programming Model for DMA Transfers

The following is the general procedure for transferring data using DMA.

1. Clear the `UARTxTXCTL/UARTxRXCTL` register to zero.
2. Configure the UART DMA parameter registers (index, modify and count).
3. Configure the `UARTxLCR`, `UARTxDLL`, `UARTxDLH`, `UARTxIER`, `UARTxSCR` and `UARTxMODE` registers.
4. Enable the DMA by setting the `UARTEN` and `DMAEN` bits in the `UARTxTXCTL/UARTxRXCTL` registers.

Setting Up and Starting Chained DMA

To start a chain pointer DMA use the following steps.

1. Clear the chain pointer register.
2. Initialize the chain pointer register with the address of the DMA descriptor table. Set the `PCI` bit if an interrupt is needed at the end of each DMA block.
3. Set up the appropriate control register to enable the UART transmitter and receiver, chain pointer, and DMA (`UARTDEN`, `UARTEN`, `UARTCHEN` bits). Once chain pointer DMA is enabled, the DMA engine fetches the index, modify, count, and chain pointer values from the memory address specified in the chain pointer register. Once the DMA parameters are fetched, normal DMA starts. This process is continued until the chain pointer register contains all zeros.

Notes on Using UART DMA

The following should be noted when performing DMA through the UART.

- DMA can be interrupted by resetting the `UARTDEN` bit, but none of the other control settings should be changed. If the UART is enabled again, then interrupted DMA can be resumed by resetting the `UARTDEN` bit.
- Disabling the UART by resetting the enable `UARTEN` bit flushes data in the transmit/receive buffer. Resetting the UART during a DMA operation is prohibited and leads to data loss.

- Do not disable chaining (UARTCHEN bit) when a chaining DMA is in progress.
- During a receive DMA, a read of the receiver buffer (UARTxRBR) is not allowed. If needed, programs should read the receiver shadow buffer (UARTxRBRSH).

Programming Model for Core Transfers

The following is the general procedure for transferring data using the core.

1. Clear the UARTxTXCTL/UARTxRXCTL registers to zero.
2. Configure the UARTxLCR, UARTxDLL, UARTxDLH, UARTxSCR and UARTxMODE registers.
3. Program the UARTxIER registers to generate interrupt when the transmit buffer is empty and/or the receive buffer is full.
4. Program the PICR registers to map the UART interrupt directly or Configure the DPI_IMASK register to enable the UART interrupts.
5. Enable the UART by setting the UARTEN bit in the UARTxTXCTL/UARTxRXCTL registers.
6. Inside the ISR, check for the interrupt triggered and write to the transmit buffer in case of transmit buffer empty and read from the receive buffer in case of receive buffer fill event.

Programming Model

15 TWO-WIRE INTERFACE CONTROLLER

The two-wire interface (TWI) controller allows a device to interface to an inter-IC bus as specified by Philips. The TWI is fully compatible with the widely used I²C bus standard. It is designed with a high level of functionality and is compatible with multi-master, multi-slave bus configurations. To preserve processor bandwidth, the TWI controller can be set up with transfer initiated interrupts to service FIFO buffer data reads and writes only. Protocol related interrupts are optional. The TWI specifications are shown in [Table 15-1](#).

Table 15-1. TWI Specifications

Feature	Availability
Connectivity	
Multiplexed Pinout	No
SRU DAI Required	No
SRU DAI Default Routing	N/A
SRU2 DPI Required	Yes
SRU2 DPI Default Routing	Yes
Interrupt Control	Yes
Protocol	
Master Capable	Yes
Slave Capable	Yes
Access Type	
Data Buffer	Yes
Core Data Access	Yes

Features

Table 15-1. TWI Specifications (Cont'd)

Feature	Availability
DMA Data Access	No
DMA Channels	N/A
DMA Chaining	N/A
Boot Capable	No
Local Memory	No
Clock Operation	PCLK

Features

The TWI is fully compatible with the widely used I²C bus standard. It was designed with a high level of functionality and is compatible with multimaster, multislave bus configurations. To preserve processor bandwidth, the TWI controller can be set up and a transfer initiated with interrupts only. This allows the processor to service FIFO buffer data reads and writes. Protocol-related interrupts are optional. The TWI master controller includes the features described in the list that follows.

- Simultaneous master and slave operation on multiple device systems
- Support for multimaster data arbitration
- 7-bit addressing
- 100K bits/second and 400K bits/second data rates
- General call address support
- Master clock synchronization and support for clock low extension
- Separate multiple-byte receive and transmit FIFOs

- Low interrupt rate
- Individual override control of data and clock lines in the event of a bus lockup
- Input filter for spike suppression

The TWI moves 8-bit data externally while maintaining compliance with the I²C bus protocol.

Pin Descriptions

Table 15-2 shows the pins for the TWI. Two bidirectional pins externally interface the TWI controller to the I²C bus. The interface is simple and no other external connections or logic are required.

Table 15-2. TWI Pins

Internal Node	Type	Description
TWI_CLK_I	I	TWI Clock Signal. Serial clock input.
TWI_DATA_I	I	TWI Data Signal. Serial receive data input.
TWI_CLK_PBEN_O	O	TWI Clock Signal. This output signal is used to drive the TWI clock off chip. Note since the TWI output signals must operate in open drain it should be routed to a DPI PBEN input.
TWI_DATA_PBEN_O	O	TWI Data Signal. This output signal is used to drive the TWI data off chip. Note that since the TWI output signals must operate in open drain it should be routed to a DPI PBEN input.

SRU Programming

The TWI signals are available through the SRU2, and are routed as described in [Table 15-3](#).

Table 15-3. TWI DPI/SRU2 Signal Connections

Internal Node	DPI Group	SRU2 Register
Inputs		
TWI_CLK_I TWI_DATA_I	Group A	SRU2_INPUT0
Outputs		
TWI_CLK_PBEN_O TWI_DATA_PBEN_O	Group C	

Clocking

The fundamental timing clock of the TWI module is peripheral clock (PCLK). Serial clock frequencies can vary from 400 kHz to less than 20 kHz. The resolution of the generated clock is 1/10 MHz or 100 ns.

$$\text{CLKDIV} = \text{TWI_CLOCK period} \div 10 \text{ MHz time reference}$$

For example, for an TWI_CLOCK of 400 kHz (period = 1/400 kHz = 2500 ns) and an internal time reference of 10 MHz (period = 100 ns):

$$\text{CLKDIV} = 2500 \text{ ns} \div 100 \text{ ns} = 25$$

For an TWI_CLOCK with a 30% duty cycle, then CLKLOW = 17 and CLKHI = 8. Note that CLKLOW and CLKHI add up to CLKDIV.

Register Overview

This section provides brief descriptions of the major registers. For complete information see [“Two-Wire Interface Registers” on page A-167](#).

Slave Mode Control Register (TWISCTL). Controls the logic associated with slave mode operation. Settings in this register do not affect master mode operation and should not be modified to control master mode functionality.

Slave Mode Status Register (TWISSTAT). During and at the conclusion of slave mode transfers, the TWISSTAT holds information on the current transfer. Generally, slave mode status bits are not associated with the generation of interrupts. Master mode operation does not affect slave mode status bits.

Master Mode Control Register (TWIMCTL). Controls the logic associated with master mode operation. Bits in this register do not affect slave mode operation and should not be modified to control slave mode functionality.

Master Mode Status Register (TWIMSTAT). Holds information during master mode transfers and at their conclusion. Generally, master mode status bits are not directly associated with the generation of interrupts but offer information on the current transfer. Slave mode operation does not affect master mode status bits.

Control Timer Register (TWIMITR). Enables the TWI module and establishes a relationship between the peripheral clock (PCLK) and the TWI controller’s internally-timed events. The internal time reference is derived from PCLK using the prescaled value shown below.

$$\text{PRESCALE} = f_{\text{PCLK}}/10 \text{ MHz}$$

Functional Description

Serial Clock Divider Register (TWIDIV). During master mode operation, the TWIDIV register values are used to create the high and low durations of the TWI_CLOCK.

FIFO Control Register (TWIFIFOCTL). The FIFO control register affects only the FIFO and is not tied in any way with master or slave mode operation.

FIFO Status Register (TWIFIFOSTAT). The fields in the TWI FIFO status register indicate the state of the FIFO buffers' receive and transmit contents. The FIFO buffers do not discriminate between master data and slave data. By using the status and control bits provided, the FIFO can be managed to allow simultaneous master and slave operation.

Functional Description

Figure 15-1 illustrates the overall architecture of the TWI controller.

The peripheral interface supports the transfer of 32-bit wide data and is used by the processor in the support of register and FIFO buffer reads and writes.

The register block contains all control and status bits and reflects what can be written or read as outlined by the programmer's model. Status bits can be updated by their respective functional blocks.

The FIFO buffer is configured as a 1-byte-wide, 2-deep transmit FIFO buffer and a 1-byte-wide, 2-deep receive FIFO buffer.

The transmit shift register serially shifts its data out externally off chip. The output can be controlled to generate acknowledgements or it can be manually overwritten.

The receive shift register receives its data serially from off chip. The receive shift register is 1 byte wide and data received can either be transferred to the FIFO buffer or used in an address comparison.

Two-Wire Interface Controller

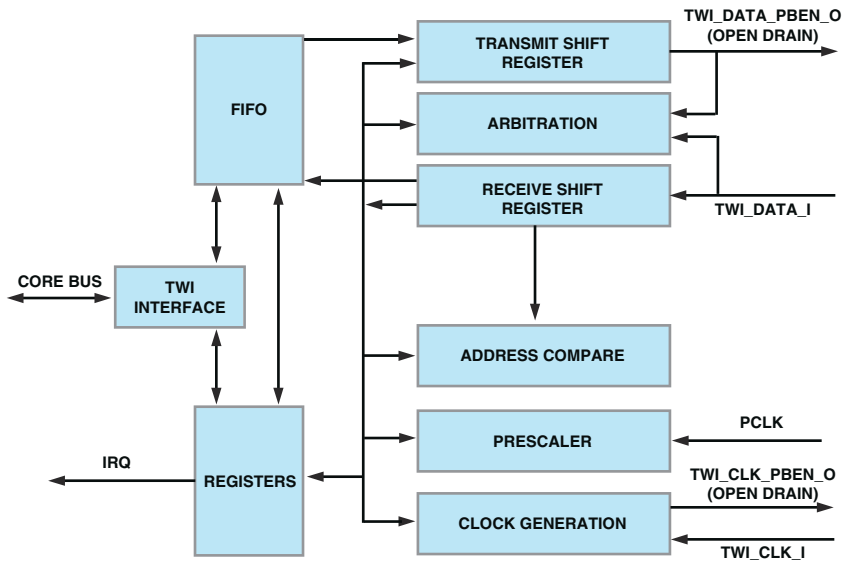

Figure 15-1. TWI Block Diagram

The address compare block supports address comparison in the event the TWI controller module is accessed as a slave.

The prescaler block must be programmed to generate a 10 MHz time reference relative to the peripheral clock. This time base is used for filtering data and timing events specified by the electrical parameters in the data sheet (see the I²C bus specification from Philips), as well as for TWI_CLOCK clock generation.

The clock generation module is used to generate an external serial clock (TWI_CLOCK) when in master mode. It includes the logic necessary for synchronization in a multimaster clock configuration and clock stretching when configured in slave mode.

The TWI controller's clock output follows these rules:

Functional Description

- Once the clock high (CLKHI) count is complete, the serial clock output is driven low and the clock low (CLKLOW) count begins.
- Once the clock low count is complete, the serial clock line is three-stated and the clock synchronization logic enters into a delay mode (shaded area) until the TWI_CLOCK line is detected at a logic 1 level. At this time, the clock high count begins.

The TWI controller only issues a clock during master mode operation and only at the time a transfer has been initiated. If arbitration for the bus is lost, the serial clock output immediately three-states. If multiple clocks attempt to drive the serial clock line, the TWI controller synchronizes its clock with the other remaining clocks. This is illustrated in [Figure 15-2](#).

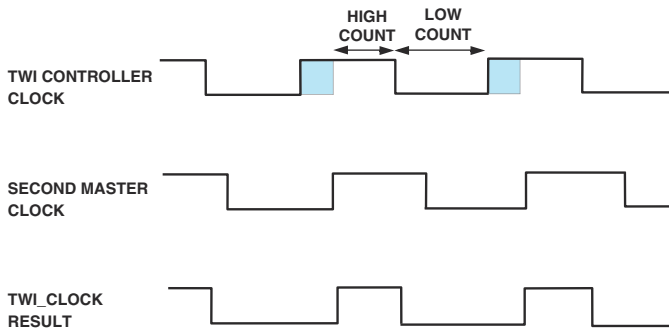

Figure 15-2. TWI Clock Synchronization

The TWI controller follows the transfer protocol of the *Philips I²C Bus Specification version 2.1* dated January 2000. A simple complete transfer is diagrammed in [Figure 15-3](#).

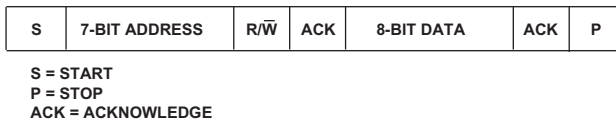

Figure 15-3. Standard Data Transfer

To better understand the mapping of TWI controller register contents to a basic transfer, [Figure 15-4](#) details the same transfer as above noting the corresponding TWI controller bit names. In this illustration, the TWI controller successfully transmits one byte of data. The slave has acknowledged both address and data.

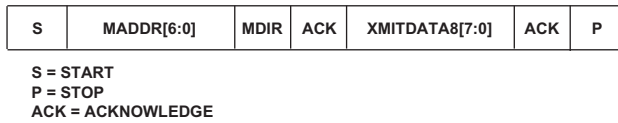

Figure 15-4. Data Transfer With Bit Illustration

Bus Arbitration

The TWI controller initiates a master mode transmission (TWIMEN) only when the bus is idle. If the bus is idle and two masters initiate a transfer, arbitration for the bus begins. This is illustrated in [Figure 15-5](#).

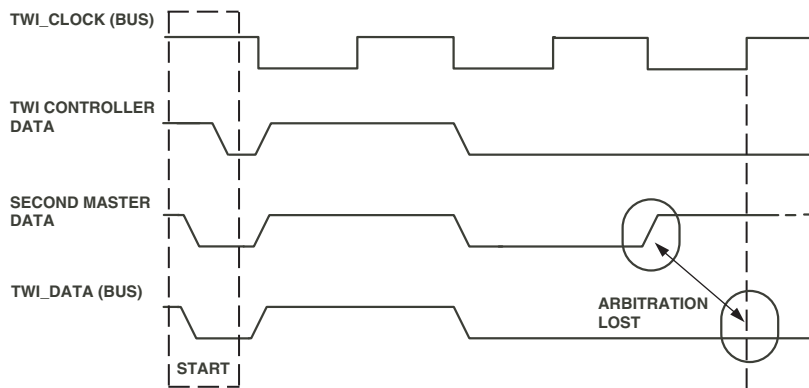

Figure 15-5. TWI Bus Arbitration

Functional Description

The TWI controller monitors the serial data bus (TWI_DATA) while the TWI_CLOCK is high. If TWI_DATA is determined to be an active logic 0 level while the internal TWI controller's data is a logic 1 level, the TWI controller has lost arbitration and ends generation of clock and data. Note that arbitration is performed not only at serial clock edges, but also during the entire time TWI_CLOCK is high.

Start and Stop Conditions

Start and stop conditions involve serial data transitions while the serial clock is at logic 1 level. The TWI controller generates and recognizes these transitions. Typically, start and stop conditions occur at the beginning and at the conclusion of a transmission, with the exception of repeated start “combined” transfers, as shown in [Figure 15-6](#).

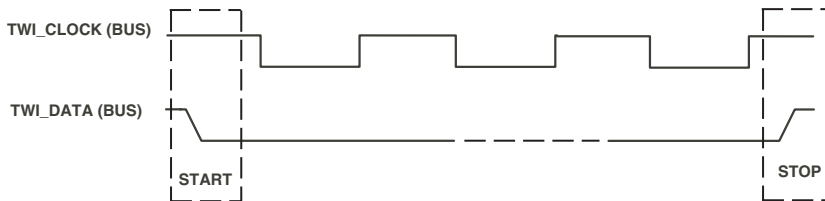

Figure 15-6. TWI Start and Stop Conditions

The TWI controller's special-case start and stop conditions include:

- TWI controller addressed as a slave-receiver

If the master asserts a stop condition during the data phase of a transfer, the TWI controller concludes the transfer (TWISCOMP).

- TWI controller addressed as a slave-transmitter

If the master asserts a stop condition during the data phase of a transfer, the TWI controller concludes the transfer (TWISCOMP) and indicates a slave transfer error (TWISERR).

- TWI controller as a master-transmitter or master-receiver

If the stop bit is set during an active master transfer, the TWI controller issues a stop condition as soon as possible to avoid any error conditions (as if data transfer count had been reached).

Slave Mode Addressing

With the appropriate selection of 7-bit addressing using the TWISLEN bit, the corresponding number of address bits (SADDR) are referenced during the address phase of a transfer.

Master Mode Addressing

Whether enabled as a master-transmitter or master-receiver with 7-bit addressing using the TWIMLEN bit, the TWI master performs all addressing and data transfers as required. This includes generating the repeated start condition, re-transmission of the 7-bits of the first address byte, and acknowledgement and generation of a new transfer direction change (indicated by the TWIMLEN bit).

Data Transfer

The TWI uses its transmit and receive buffers for data transfer (no DMA capability). These buffers are described in the following sections.

Data Buffers

The TWI has two data buffer FIFOs, which are described in the following sections.

Data Transfer

8-Bit Transmit FIFO Register

The TWI 8-bit transmit FIFO register (TXTWI8) shown in [Figure 15-7](#), holds an 8-bit data value written into the FIFO buffer. Transmit data is entered into the corresponding transmit buffer in a first-in, first-out order. Although peripheral bus writes are 32 bits, a write access to the TXTWI8 register adds only one transmit data byte to the FIFO buffer. With each access, the transmit status (TWITXS) field in the TWIFIFOSTAT register is updated. If an access is performed while the FIFO buffer is full, the core waits until there is at least one byte space in the transmit FIFO buffer and then completes the write access.

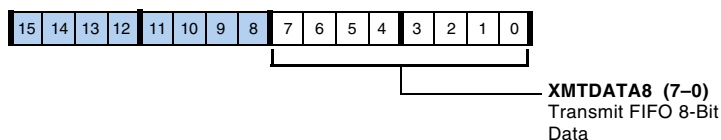

Figure 15-7. 8-Bit Transmit FIFO Register

16-Bit Transmit FIFO Register

The TWI 16-bit FIFO transmit register (TXTWI16) shown in [Figure 15-8](#), holds a 16-bit data value written into the FIFO buffer. Although peripheral bus writes are 32 bits, a write access to the TXTWI16 register adds only two transmit data bytes to the FIFO buffer. To reduce interrupt output rates and peripheral bus access times, a double byte transfer data access can be performed. Two data bytes can be written, effectively filling the transmit FIFO buffer with a single access.

The data is written in little-endian byte order as shown in [Figure 15-8](#), where byte 0 is the first byte to be transferred and byte 1 is the second byte to be transferred. With each access, the transmit status (TWITXS) field in the TWIFIFOSTAT register is updated. If an access is performed while the FIFO buffer is not empty, the core waits until the FIFO buffer is completely empty and then completes the write access.

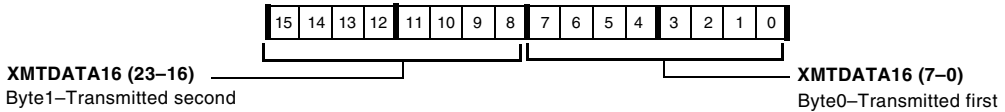

Figure 15-8. 16-Bit Transmit FIFO Register

8-Bit Receive FIFO Register

The TWI 8-bit FIFO receive register (`RXTWI8`) shown in [Figure 15-9](#), holds an 8-bit data value read from the FIFO buffer. Receive data is read from the corresponding receive buffer in a first-in, first-out order. Although peripheral bus reads are 32 bits, a read access to the `RXTWI8` register can only access one receive data byte from the FIFO buffer. With each access, the receive status (`TWIRXS`) field in the `TWIFIFOSTAT` register is updated. If an access is performed while the FIFO buffer is empty, the core waits until there is at least one byte in the receive FIFO buffer and then completes the read access.

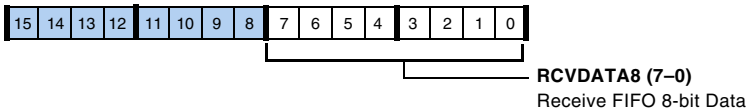

Figure 15-9. 8-Bit Receive FIFO Register

16-Bit Receive FIFO Register

The TWI 16-bit FIFO receive register (`RXTWI16`) shown in [Figure 15-10](#), holds a 16-bit data value read from the FIFO buffer. Although peripheral bus reads are 32 bits, a read access to the `RXTWI16` register can only access two receive data bytes from the FIFO buffer. To reduce interrupt output rates and peripheral bus access times, a double-byte receive data access can be performed. Two data bytes can be read, effectively emptying the receive FIFO buffer with a single access.

Operating Modes

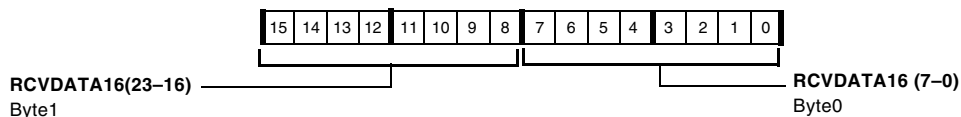

Figure 15-10. 16-Bit Receive FIFO Register

The data is read in little-endian byte order, where byte 0 is the first byte received and byte 1 is the second byte received. With each access, the receive status (`TWIRXS`) field in the `TWIFIFOSTAT` register is updated to indicate it is empty. If an access is performed while the FIFO buffer is not full, the core waits until the receive FIFO buffer is full and then completes the read access.

Operating Modes

The following sections provide information on the operation modes of the interface.

General Call Addressing

The TWI controller always decodes and acknowledges a general call address if it is enabled as a slave (`TWISEN`) and if general call is enabled using the `TWIGCE` bit. General call addressing (0x00) is indicated by the setting of the `GCALL` bit, and by the nature of the transfer, the TWI controller is a slave-receiver. If the data associated with the transfer is to be not acknowledged (NAKed), the `TWINAK` bit can be set.

If the TWI controller is to issue a general call as a master-transmitter, the appropriate address and transfer direction can be set along with loading transmit FIFO data.

Fast Mode

Fast mode essentially uses the same mechanics as standard mode. It is the electrical specifications and timing that are different. When fast mode is enabled using the `TWIFAST` bit, the following timings are modified to meet the electrical requirements.

- Serial data rise times before arbitration evaluation (t_r)
- Stop condition setup time from serial clock to serial data (t_{SUSTO})
- Bus free time between a stop and start condition (t_{BUF})

Interrupts

The following sections provide information on the TWI and interrupt generation. [Table 15-4](#) provides an overview of TWI interrupts.

Table 15-4. TWI Interrupt Overview

Interrupt Source	Interrupt Condition	Interrupt Completion	Interrupt Acknowledge	Default IVT
DPI TWI (TX/RX)	– Master (TX completion, TX/RX buffer service, error) – slave (initiative, completion, overflow, error)	Internal transfer completion	W1C (Write one to clear) TWIIRPTL register + RTI instruction	P14I
TWI(TX/RX)	– Master (TX completion, TX/RX buffer service, error) – slave (initiative, completion, overflow, error)	Internal transfer completion	W1C (Write one to clear) TWIIRPTL register + RTI instruction	Need to route TWII (PICRx) to any PxxI

Interrupts



If TWI interrupts are routed via the DPI interrupt, programs do not need to also read the `DPI_IRPTL` register for interrupt acknowledgment. A write to clear the `TWIIIRPTL` register also clears the `DPI_IRPTL` register.

Interrupt Routing

The following sections describe the various possibilities for routing a TWI interrupt to the interrupt vector table (IVT).

DPI

The TWI interrupt is combined into the digital peripheral interface (DPI) interrupt. The `DPI_IMASK` register determines whether an interrupt is generated. [Listing 15-1](#) shows an example of how to enable the TWI over the DPI.

Listing 15-1. Enabling DPI TWI Interrupts

```
bit set mode1 IRPTEN;          /* enables global interrupts */
bit set imask DPII;           /* unmask DPI interrupt */
ustat1 = TWI_INT;
dm(DPI_IMASK_RE) = ustat1;    /* unmask TWI interrupt */
```

TWI

The TWI receive and transmit interrupts can also be programmed through the peripheral interrupt control registers (`PICRx`) as separate interrupts. (By default, these interrupts are not configured in the `IRPTL` register—the `PICRx` register has to be programmed to configure them.) This method shown in [Listing 15-2](#) uses the `PICR` register with the code value of the `UARTx_RXI` or `UARTx_TXI` interrupts.

Listing 15-2. Enabling UART Interrupts

```
bit set mode1 IRPTEN;           /* enables global interrupts */
bit set imask P1I;             /* unmask P1I interrupt */
ustat1=dm(PICR0);             /* route TWII 0x17 to P1I */
bit set ustat1 P1I4|P1I2|P1I1|P1I0;
bit clr ustat1 P1I3;
dm(PICR0)=ustat1;
```

Interrupt Sources

The six different types of interrupts used by the TWI are grouped according to master, slave or error operation. Those used in slave operation are:

- Transfer Initiate
- Transfer Complete

and for master operation:

- Transfer Complete
- TX/RX Buffer service

and for error operation

- Transfer Error
- Transfer Overflow

For interrupt execution, the specific `TWIRXINT` receive bit or the specific `TWITXINT` transmit bit must be enabled in the `TWIIIMASK` register. The `IMASK` or `LIRPTL` registers must also be configured based on the programmable interrupt to be used. The ISR needs to clear the status bits of the `TWIIIRPTL` register by explicitly writing 1 into the status bit (W1C) as shown in [Listing 15-3](#).

Debug Features

Listing 15-3.

```
TWI_ISR:
ustat1 = dm(TWIIRPTL);
bit set ustat1 TWITXINT;
dm(TWIIRPTL) = ustat1;    /* W1C to clear TWI TX interrupt */
R10=dm(TWICTL);          /* dummy read for interrupt latency */
instruction;
rti;
```

Debug Features

The following section provides information on debugging features available with the TWI.

Buffer Hang Disable

To support debugging buffer transfers, the processors have a buffer hang disable (BHD) bit in the TWIFIFOCTL register. When set (=1), this bit prevents the processor core from detecting a buffer-related stall condition, permitting debugging of this type of stall condition. For more information, see [“Buffer Hang Disable \(BHD\)” on page 7-54](#).

Loop Back Routing

The controller supports an internal loop back mode by using the SRU. [For more information, see “Loop Back Routing” on page 6-41](#).

Effect Latency

The total effect latency is a combination of the write effect latency (core access) plus the peripheral effect latency (peripheral specific).

Write Effect Latency

For details on write effect latency, see *SHARC Processor Programming Reference*.

TWI Effect Latency

After the TWI registers are configured the effect latency is 1.5 PCLK cycles minimum and 2 PCLK cycles maximum.

Programming Model

The following sections include information for general setup, slave mode, and master mode, as well as guidance for repeated start conditions.

General Setup

General setup refers to register writes that are required for both slave mode and master mode operation. General setup should be performed before either the master or slave enable bits are set.

Programs should enable the TWI controller through the TWIMITR register and set the prescale value. Program the prescale value to the binary representation of $f_{PCLK}/10$ MHz.

All values should be rounded up to the next whole number. The TWIEN enable bit must be set. Note that once the TWI controller is enabled, a bus busy condition may be detected.

Slave Mode

When enabled, slave mode supports both receive and transmit data transfers. It is not possible to enable only one data transfer direction and not acknowledge (NAK) the other. This is reflected in the following setup.

1. Program the `TWISADDR` register. The appropriate 7 bits are used in determining a match during the address phase of the transfer.
2. Program the `TXTWI8` or `TXTWI16` register. These are the initial data values to be transmitted in the event the slave is addressed as a transmitter. This is an optional step. If no data is written and the slave is addressed and a transmit is required, the `TWI_CLOCK` is stretched and an interrupt is generated.
3. Program the `TWIFIFOCTL` register. Indicate if transmit (or receive) FIFO buffer interrupts should occur with each byte transmitted (received) or with each 2 bytes transmitted (received).
4. Program the `TWIIMASK` register. Enable bits associated with the desired interrupt sources. As an example, programming the value `0x000F` results in an interrupt output to the processor when a valid address match is detected, a valid slave transfer completes, a slave transfer has an error, or a subsequent transfer has begun but the previous transfer has not been serviced.
5. Program the `TWISCTL` register. This prepares and enables slave mode operation. As an example, programming the value `0x0005` enables slave mode operation, requires 7-bit addressing, and indicates that data in the transmit FIFO buffer is intended for slave mode transmission.

Table 15-5 shows what the interaction between the TWI controller and the processor might look like when the slave is addressed as a receiver.

Table 15-5. Slave Mode Setup Interaction (Slave Addressed as Receiver)

TWI Controller Master	Processor
Interrupt: TWISINIT – Slave transfer has been initiated.	Change on the next sides always. Interrupt Acknowledge: W1C the TWIIRPTL register.
Interrupt: TWIRXS – Receive buffer has 1 or 2 bytes (according to TWIRXINT).	Read receive FIFO buffer. Change on the next sides always. Interrupt Acknowledge: W1C the TWIIRPTL register
...	...
Interrupt: TWISCOMP – Slave transfer complete.	Read receive FIFO buffer. Acknowledge: Clear interrupt source bits.

Master Mode Clock Setup

Master mode operation is set up and executed on a per-transfer basis. An example of programming steps for a receive and for a transmit are given separately in following sections. The clock setup programming step listed here is common to both transfer types.

Program the `TWIDIV` register. This defines the clock high duration and clock low duration.

Master Mode Transmit

Follow these programming steps for a single master mode transmit:

1. Program the `TWIMADDR` register. This defines the address transmitted during the address phase of the transfer.
2. Program the `TXTWI8` or `TXTWI16` registers. This is the initial data transmitted. It is considered an error to complete the address phase of the transfer and not have data available in the transmit FIFO buffer.
3. Program the `TWIFIFOCTL` register. Indicate if transmit FIFO buffer interrupts should occur with each byte transmitted (8 bits) or with each 2 bytes transmitted (16 bits).
4. Program the `TWIIMASK` register. Enable the bits associated with the desired interrupt sources. For example, programming the value `0x0030` results in an interrupt output to the processor when the master transfer completes, or if a master transfer error has occurred.
5. Program the `TWIMCTL` register. This prepares and enables master mode operation. As an example, programming the value `0x0201` enables master mode operation, generates a 7-bit address, sets the direction to master-transmit, uses standard mode timing, and transmits 8 data bytes before generating a stop condition.

Table 15-6 shows what the interaction between the TWI controller and the processor might look like using this example.

Table 15-6. Master Mode Transmit Setup Interaction

TWI Controller Master	Processor
Interrupt: TWITXINT – Transmit buffer has 1 or 2 bytes empty (according to XMTINTLEN).	Write transmit FIFO buffer. Change on the next sides always. Interrupt Acknowledge: WIC the TWIIRPTL register.
...	...
Interrupt: TWIMCOMP – Master transfer complete.	Change on the next sides always. Interrupt Acknowledge: WIC the TWIIRPTL register

Master Mode Receive

Follow these programming steps for a single master mode transmit:

1. Program the TWIMADDR register. This defines the address transmitted during the address phase of the transfer.
2. Program the TWIFIFOCTL register. Indicate if receive FIFO buffer interrupts should occur with each byte received (8 bits) or with each 2 bytes received (16 bits).
3. Program the TWIIMASK register. Enable bits associated with the desired interrupt sources. For example, programming the value 0x0030 results in an interrupt output to the processor in the event that the master transfer completes, and the master transfer has an error.

Programming Model

4. Program the `TWIMCTL` register. Ultimately this prepares and enables master mode operation. As an example, programming the value `0x0201` enables master mode operation, generates a 7-bit address, sets the direction to master-receive, uses standard mode timing, and receives 8 data bytes before generating a stop condition.

Table 15-7 shows what the interaction between the TWI controller and the processor might look like using this example.

Table 15-7. Master Mode Receive Setup Interaction

TWI Controller Master	Processor
Interrupt: <code>TWIRXINT</code> – Receive buffer has 1 or 2 bytes (according to <code>RCVINTLEN</code>).	Read receive FIFO buffer. Change on the next sides always. Interrupt Acknowledge: W1C the <code>TWIIRPTL</code> register.
...	...
Interrupt: <code>TWIMCOMP</code> – Master transfer complete.	Read receive FIFO buffer. Change on the next sides always. Interrupt Acknowledge: W1C the <code>TWIIRPTL</code> register.

Repeated Start Condition

In general, a repeated start condition is the absence of a stop condition between two transfers initiated by the same master. The two transfers can be of any direction type. Examples include a transmit followed by a receive, or a receive followed by a transmit. During a repeated start transfer, each interrupt must be serviced correctly to avoid errors. The following sections are intended to assist the programmer with service routine development.

Transmit/Receive Repeated Start Sequence

Figure 15-11 illustrates a repeated start data transmit followed by a data receive sequence. Note that shading indicates that the slave has the bus.

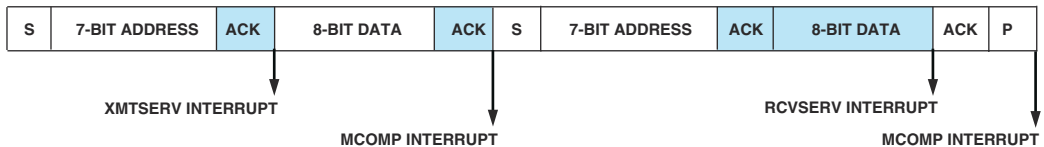

Figure 15-11. Transmit/Receive Data Repeated Start

The tasks performed at each interrupt are:

- TWITXINT interrupt

This interrupt is generated every time the transmit FIFO has one or two byte locations available to be written. To service this interrupt, write a byte or word into the transmit FIFO registers (TXTWI8 or TXTWI16). During one of these interrupts (preferably the first time), do the following:

- Set the RSTART bit (or earlier when TWIMCTL register is programmed first).
- Set the TWIMDIR bit to indicate the next transfer direction is receive. This should be done before the addressing phase of the next transfer begins.

- TWIMCOMP interrupt

This interrupt is generated because all data has been transferred (DCNT = 0). If no errors were generated, a start condition is initiated. At this time, program the following bits of TWI_MASTER_CTRL register:

- Clear RSTART (if this is the last transfer).

Programming Model

- Re-program `DCNT` with the desired number of bytes to receive.
- `TWISERR` interrupt

This interrupt is generated due to the arrival of a byte into the receive FIFO. Simple data handling is all that is required.

Receive/Transmit Repeated Start Sequence

Figure 15-12 illustrates a repeated start data receive followed by a data transmit sequence. The shading indicates the slave has the bus.

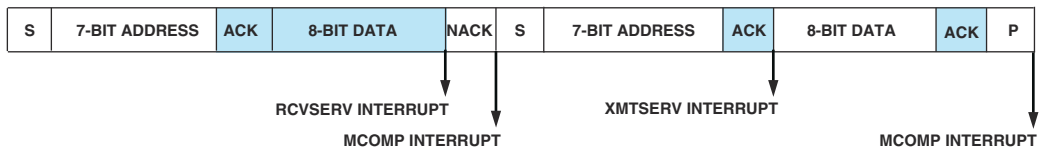

SHADING INDICATES SLAVE HAS THE BUS

Figure 15-12. Receive/Transmit Data Repeated Start

The tasks performed at each interrupt are:

- `TWIRXINT` interrupt

This interrupt is generated due to the arrival of one or two data bytes into the receive FIFO. The `TWIRSTART` bit should be set at this time (or earlier) and `MDIR` should be cleared to reflect the change in direction of the next transfer. The `TWIMDIR` bit must be cleared before the addressing phase of the subsequent transfer begins.

- TWIMCOMP interrupt

This interrupt has occurred due to the completion of the data receive transfer. At this time the data transmit transfer begins. The TWIDCNT field should be set to reflect the number of bytes to be transmitted. Clear the TWIRSTART bit if this is the last transfer.

- TWITXINT interrupt

This interrupt is generated when there is one or two bytes of empty space in the FIFO. Simple data handling is all that is required.

- TWIMCOM interrupt

The transfer is complete.

Electrical Specifications

All logic complies with the electrical specification outlined in the *Philips I²C Bus Specification version 2.1* dated January, 2000.

Electrical Specifications

16 POWER MANAGEMENT

Power management is a vital tool that system designers can employ to control internal and external clocking and maximize power savings.

Features

The following list describes the power management features.

- The PLL has various multiplier and divisor settings to generate a flexible core clock
- Allows changes to the output clock during runtime.
- $\overline{\text{RESETOUT}}$ pin can be used for boot handshake or as a debug aid.
- Resetting the PLL is possible without performing a new power-up sequence.
- Power savings controls the shut-down of individual clocks to peripherals.

Register Overview

Power Management Control Register (PMCTL). Governs the operation of the PLL and configures and controls all PLL settings. This register also controls the peripheral's clocks.

Phase-Locked Loop (PLL)

Phase-Locked Loop (PLL)

The following sections describe the clocking system of the SHARC processor. This information is critical to ensure designs that work correctly and efficiently.

Functional Description

To provide the clock generation for the core and system, the processor uses an analog PLL with programmable state machine control. The PLL design serves a wide range of applications. It emphasizes embedded applications and low cost for general-purpose processors, in which performance, flexibility, and control of power dissipation are key features. This broad range of applications requires a range of frequencies for the clock generation circuitry. The input clock may be a crystal, an oscillator, or a buffered, shaped clock derived from an external system clock oscillator. The clock system is shown in [Figure 16-1](#).

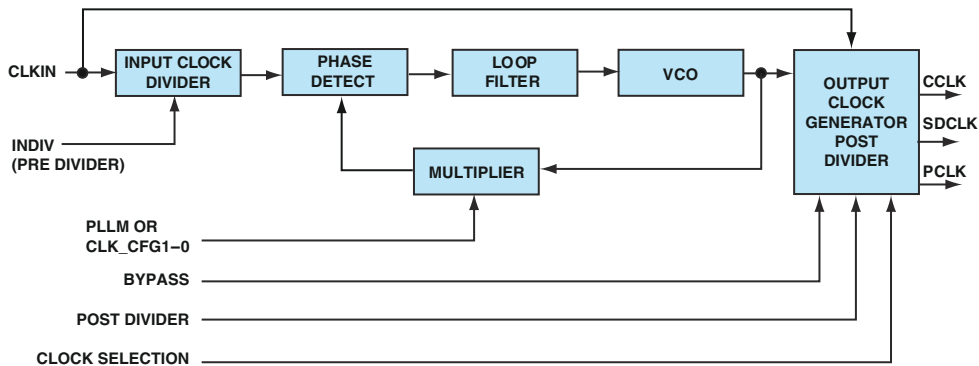

Figure 16-1. Clocking System

Subject to the maximum VCO frequency, the PLL supports a wide range of multiplier ratios of the input clock, **CLKIN**. To achieve this wide

multiplication range, the processor uses a combination of programmable multipliers in the PLL feedback circuit and output configuration blocks.

The processor uses an on-chip, phase-locked loop (PLL) to generate its internal clock, which is a multiple of the $CLKIN$ frequency. The PLL requires some time to achieve phase lock and $CLKIN$ must be valid for a minimum time period during reset before the \overline{RESET} signal can be deasserted. For information on minimum clock setup, external crystal use, and range for any given $CLKIN$ frequency, see the appropriate product data sheet.



A detailed diagram along with specific equations on the derivation of VCO frequency with reference to $CLKIN$ can be found in the appropriate product data sheet.

PLL Input Clock

If an external clock oscillator is used, it should NOT drive the $CLKIN$ pin when the processor is not powered. The clock must be driven immediately after power-up; otherwise, internal gates stay in an undefined (hot) state and can draw excess current. After power-up, allow sufficient time for the oscillator to start up, reach full amplitude, and deliver a stable $CLKIN$ signal to the processor before the reset is released. This may take several milliseconds and depends on the choice of crystal, operating frequency, loop gain and capacitor ratios. For details on timing, refer to the appropriate product data sheet.

Pre Divider Input

This unit divides the PLL input clock by 2 if enabled (using the $INDIV$ bit). The pre divider input is part of the PLL loop, therefore, if a program changes the PLL input clock (affecting the VCO frequency), the PLL must be put in bypass mode before the change is made. This is described in [“Bypass Mode” on page 16-7](#).

Phase-Locked Loop (PLL)

PLL Multiplier

The PLL multiplier is controlled by hardware or software and based on the PLL multiplier settings below.

- Hardware—through the clock configuration pins (CLK_CFG1-0)
- Software—the hardware settings are overridden through the PLLM bits

PLLM Hardware Control

On power-up, the CLK_CFG1-0 pins are used to select core to CLKIN ratios which cannot be changed during runtime. After booting however, numerous other ratios (slowing or speeding up the clock) can be selected through software control.

Table 16-1 describes the internal clock to CLKIN frequency ratios supported by the processor.

Table 16-1. Pin Selectable Clock Rate Ratios

CLKCFG1-0	Core to CLKIN Ratio
00	6:1
01	32:1
10	16:1
11	Reserved

PLLM Software Control

Programs control the PLL through the PMCTL register. The PLL multiplier (PLLM) bits can be configured to set a multiplier range of 0 to 63. This allows the PLL to be programmed dynamically in software to achieve a higher or slower core instruction rate depending on a particular system's requirements.

The reset value of the PLLM bits is derived from the CLK_CFG1-0 pin multiply ratio settings. This value can be reprogrammed in the boot kernel to take effect immediately after startup.

PLL VCO

The VCO is the PLL output stage of the PLL. It feeds the output clock generator which provides core and peripheral clocks as shown in [Table 16-2](#). Two settings have an impact on the VCO frequency:

- The INDIV bit enables the CLKIN input pre-divider by 2.
- The PLLM bits and the CLK_CFG1-0 pins control the PLL multiplier unit.

Changing the VCO frequency requires a new condition for the PLL circuitry. Therefore, the core needs to wait a specific settling time in bypass mode before it can be released for further activities (typically 4096 CLKIN cycles).

Table 16-2. VCO Encodings

PLLM Bit Settings	VCO Frequency ¹	
	INDIV = 0	INDIV = 1
0	128x	64x
1	2x	1x
2	4x	2x
N = 3–62	2Nx	Nx
63	126x	63x

¹ For operational limits for the VCO clock see the appropriate product data sheet.

Phase-Locked Loop (PLL)

Output Clock Generator

The output clock generator post divides the VCO clock to the core ratio or peripherals ratio and synchronizes all output clocks. It is fed with the VCO clock and does not provide any feedback back to the PLL circuit.

If the `DIVEN` bit is set, new post divider ratios are picked up on the fly and the clocks smoothly transition to their new values within 14 core clock (`CCLK`) cycles.

 Post divider ratio changes (`PLLD` bits) do not require bypass mode.

The output clock generator block also controls bypass mode. For a description of the `PMCTL` bits, see [“Power Management Control Registers \(PMCTL\)” on page A-7](#).

Core Clock (CCLK)

The `PLLD` bits define the VCO output clock to core clock ratio to build the processor core clock (`CCLK`). The post divider can be changed any time and new division ratios are implemented on the fly.

IOP Clock (PCLK)

The peripheral clock is derived from the core clock with a fixed post divisor of 2. This clock is the master clock for all peripherals (except SDRAM) including the I/O processor (IOP).

SDRAM Clock (SDCLK)

The SDRAM clock is derived from the core clock with post dividers. This clock is the master clock for the SDRAM controller. [For more information, see “Clocking” on page 3-5](#).

Default PLL Hardware Settings

Table 16-3 demonstrates the internal core clock switching frequency across a range of CLKIN frequencies. The minimum operational range for any given frequency may be constrained by the operating range of the phase-locked loop. Note that the goal in selecting a particular clock ratio for an application is to provide the highest permissible internal frequency for a given CLKIN frequency. For more information on available clock rates, see the appropriate product data sheet.

Table 16-3. Selecting Core to CLKIN Ratio

		Typical Crystal and Clock Oscillators Inputs					
		12.500	16.667	25.000	33.333	40.000	50.000
Clock Ratios (CLK_CFG Pins)	Core CLK (MHz) ¹						
	6:1	N/A	100	150	200	240	300
	16:1	200	266.66	400	N/A	N/A	N/A
	32:1	400	N/A	N/A	N/A	N/A	N/A

¹ For operational limits for the core clock frequency see the appropriate product data sheet.

Operating Modes

The following sections provide information on the various options for clock operation.

Bypass Mode

Bypass mode must be used if any runtime VCO clock change is required. Setting the PLLBP bit bypasses the entire PLL circuitry. In bypass mode, the core runs at CLKIN speed. Once the PLL has settled into the new VCO frequency, (which may take 4096 CLKIN cycles) the PLLBP bit may be

Power-Up Sequence

cleared to release the core from bypass mode. [For more information, see “Back to Back Bypass” on page 16-15.](#)

 Only VCO frequency changes require bypass mode, therefore this mode is not intended as a standard operating mode.

Normal Mode

The normal mode is the regular mode and is effective if the `PLLBP` bit is cleared. In normal mode the PLL has locked and multiplies `CLKIN` to the desired VCO clock. The output clock generator post divides and provides the clock tree to the I/O.

Clocking Golden Rules

The five rules below should be followed to ensure proper processor operation.

1. After power-up the `CLK_CFG` pins should not exceed the maximum core speed.
2. Software should guarantee minimum/maximum `CCLK` speed.
3. Software should guarantee maximum VCO clock speed.
4. Bypass requires 4096 `CLKIN` cycles.
5. Post divider changes require 15 `CCLK` cycles.

Power-Up Sequence

The proper power-up sequence is critical to correct processor operation as described in the following sections.

PLL Start-Up

Before the PLL can start settling, the $\overline{\text{RESET}}$ signal should be asserted for several micro-seconds under the following conditions. For PLL information, see the appropriate product data sheet.

- Valid and stable core voltage (V_{DDINT})
- Valid and stable I/O voltage (V_{DDEXT})
- Valid and stable clock input (CLKIN)

The chip reset circuit is shown in [Figure 16-2](#). The PLL needs time to lock to the CLKIN frequency before the core can execute or begin the boot process. A delayed core reset signal ($\overline{\text{RESETOUT}}$) is triggered by a 12-bit counter after $\overline{\text{RESET}}$ is transitioned from low to high (approximately 400 μs for minimum CLKIN). The delay circuit is activated at the same time the PLL is triggered for settling after reset is de-asserted.

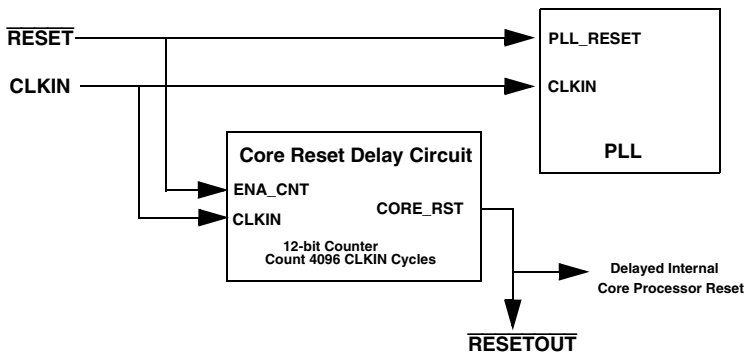



Figure 16-2. Chip Reset Circuit

Power Management

After the external processor $\overline{\text{RESET}}$ signal is deasserted, the PLL starts settling. The rest of the chip is held in reset for 4096 CLKIN cycles after $\overline{\text{RESET}}$ is deasserted by an internal reset signal.

 The advantage of the delayed core reset is that the PLL can be reset any number of times without having to power down the system. If there is a brownout situation, the external watchdog circuit only has to control the $\overline{\text{RESET}}$ signal. For more information on device power-up, see the appropriate product data sheet.

Power Management

The processor allows systems to shut down the clock to the different modules in the peripheral domain in order to save power if the peripherals are not required by the application.

Peripherals

All internal clocks to the peripherals are enabled by default. However, they can be disabled using the PMCTL register.

The PMCTL register allow programs to disable the clock source to a particular processor peripheral (for example the external port) to further conserve power. Programs can use the PMCTL register to turn the specific peripheral off after the application no longer needs it. For a complete register description, see [“Power Management Control Registers \(PMCTL\)” on page A-7](#).

DAI Routing Unit

To further preserve power, the clock to the DAI routing unit can be disabled using bit 4 in the PMCTL register. If, for example, a system requires the SPORTs, the DAI system routing can be configured and then bit 4

can be cleared to disable the routing block. Note that the SPORT continues to operate as long as the SPORT clocks themselves are not shut down.

External Port Control

The `EPOFF` bit in the `PMCTL` register allows programs to disconnect the clocks to the SDRAM and AMI modules in order to save power if the controllers are not used. Note that if the SDRAM controller is used but pauses, the self-refresh mode also helps to reduce power consumption. [For more information, see “SDRAM Controller” on page 3-16.](#)

If `SDCLK1` is not used in a system (in self-refresh mode or otherwise), it can be stopped by setting the `DSDCLK1` bit in the `SDCTL` control register. This reduces the power consumption in a system.

However, `SDCLK0` must remain enabled at all times except in self-refresh mode (if the SDRAM interface is used), as it is needed to generate auto-refresh commands to the SDRAM memory device.

Example for Clock Management

[Listing 16-1](#) shows a method for using the power saving features in the SHARC processors for the SPI.

Listing 16-1. Power Savings for the SPI Module

```
ustat2 = dm(PMCTL);
bit set ustat2 SPIOFF; /* disable internal peripheral clock for
                        SPI module. /
dm(PMCTL) = ustat2;
```

Programming Model

General Notes on Power Savings

The following are some additional methods for reducing power.

- The lower the operation frequency, the lower the power consumption. The core and peripherals should be operated at the lowest frequency that meets the system's requirements. Active power is proportional to the processor's core clock frequency.
- Reducing the case temperature lowers leakage power. Leakage power increases exponentially to junction temperature.
- For core pauses programs should execute the `IDLE` instruction. Note that an interrupt is required to release the processor from `IDLE`.
- Don't leave input pins floating. In some cases leakage draws current in the region of milliamps. For more information, consult the product-specific data sheet. If an external resistor is problematic, change the input to an output if possible (flag input).
- If a DAI/DPI pin is not being used, its pin enable (for example `DAI_PBenxx_I`) and its input (`DAI_PBxx_I`) for its pin buffer should be connected to low and its associated bit in the `DAI/DPI_PIN_PULLUP` register should be set (= 1) to enable a pull-up resistor for that pin.
- Disable the S/PDIF receiver and its digital PLL from the S/PDIF receiver. By default the S/PDIF receiver is enabled. If not required set the `DIR_RESET` bit (=1) to disable the digital PLL which may produce unwanted switching noise if enabled.

Programming Model

For SDRAM programming models, see [“SDRAM Controller” on page 3-98](#).

Post Divider

Use the following procedure and the example shown in [Listing 16-2](#) to program or re configure the divider.

1. Disable any peripheral (configured with `PCLK=CCLK/2`). Note that the peripherals cannot be enabled when changing VCO to core clock ratio.
2. Select the PLLD divider by setting the PLLD bits (6–7) in the `PMCTL` register and enable the `DIVEN` bit.
3. Wait 15 `CCLK` cycles. During this time, the new divisor ratios are picked up on the fly and the clocks smoothly transition to their new values after a maximum of 14 core clock `CCLK` cycles.
4. Re-enable the peripherals.

Listing 16-2. Post Divider

```

ustat2 = dm(PMCTL);
bit clr ustat2 PLLBP;          /* bypass disabled*/
bit set ustat2 DIVEN|PLLD4;    /* set and enable post divisor */
dm(PMCTL) = ustat2;
lcntr = 15, do wait until lce;
wait: nop;

```

Multiplier and Post Divider Programming Model

There are two allowable procedures to program the VCO. The first method is shown in [Listing 16-3](#).

1. Set the PLL multiplier and divisor value and enable the divisor by setting the `DIVEN` bit.
2. After one core clock cycle, place the PLL in bypass mode by setting (= 1) the `PLLBP` bit.

Programming Model

3. Wait in bypass mode until the PLL locks (4096 CLKIN cycles).
4. Take the PLL out of bypass mode by clearing (= 0) the bypass bit.
5. Wait 15 core cycles before next activity.

The second method is:

1. Set the PLL multiplier and divisor values and place the PLL in bypass mode by setting the PLLBP bit.
2. Wait in the bypass mode until the PLL locks (4096 CLKIN cycles).
3. Take the PLL out of bypass mode by clearing the bypass bit.
4. Wait for one core clock cycle.
5. Enable the divisor by setting the DIVEN bit.
6. Wait 15 core cycles before next activity.

Listing 16-3. VCO Programming

```
ustat2 = dm(PMCTL);
bit set ustat2 DIVEN | PLLD4 | PLLM16; /* set a multiplier of
                                         16 and a divider of 4 */
dm(PMCTL) = ustat2;
bit set ustat2 PLLBP; /* Put PLL in bypass mode. */
bit clr ustat2 DIVEN; /* clear the DIVEN bit */

dm(PMCTL) = ustat2; /* The DIVEN bit should be cleared
                    while placing the PLL in bypass mode */
waiting_loop:
r0 = 4096; /* wait for PLL to lock at new rate
           (requirement for VCO change) */
lcntr = r0, do pllwait until lce;
```

```
pllwait: nop;

ustat2 = dm(PMCTL);    /* Reading the PMCTL register value
                       returns the DIVEN bit value as zero */

bit clr ustat2 PLLBP; /* take PLL out of Bypass, PLL is now at
                       new CCLK) */

dm(PMCTL) = ustat2;   /* The DIVEN bit should be cleared while
                       taking the PLL out of bypass mode */
```

Back to Back Bypass

Use this steps and the example shown in [Listing 16-4](#) if the application needs to re-enter the bypass mode.

1. Disable the bypass bit in the PMCTL register.
2. Wait 6 core clock cycles.
3. Enable the bypass bit.

Listing 16-4. Back to Back Bypass

```
ustat3 = dm(PMCTL);
bit clr ustat3 PLLBP;
dm(PMCTL) = ustat3;    /* PLLBP is cleared */
nop;nop;nop;nop;
ustat4 = dm(PMCTL);
bit set ustat4 PLLBP;
dm(PMCTL) = ustat4;   /* PLLBP is set */
```

Programming Model

17 SYSTEM DESIGN

This chapter discusses different processor reset methods, boot modes and pin multiplexing. In addition, information about high speed design is illustrated with some examples of supervisor circuits used in conjunction with the SHARC processor. These topics are located in the following sections.

- “Circuit Board Design” on page 17-33
- “Pin Descriptions” on page 17-2
- “System Components” on page 17-41
- “High Frequency Design” on page 17-33
- “Processor Booting” on page 17-7



Before proceeding with this chapter it is recommended that you become familiar with the SHARC core architecture. This information is presented in *SHARC Processor Programming Reference*.

Features

The following list describes the features for reset and multiplexing.

- Four reset options: hardware, software, running reset and emulation.
- Different master or slave boot mechanisms.
- Hardware and software reset for processor booting.
- Two pin multiplexing groups: core flag pins and external port pins.
- DAI/DPI units work together with multiplexing logic provides system design flexibility.

Pin Descriptions

Refer to the appropriate product data sheet for pin information, including package pinouts for the currently available package options.

Register Overview

The following registers are used for processor reset, booting, and pin multiplexing.

Software Reset Control Register (SYSCTL). Controls the software reset mechanism.

Running Reset control register (RUNRSTCTL). Controls the functionality of the `RESETOUT` pin as running reset input.

External Port Control Register (EPCTL). Controls the memory chip selects for AMI on the external port memory space during boot.

External Port DMA Control Register (DMACx). Controls the receive configuration for external boot DMA.

AMI Control Register (AMICTL1). Controls the AMI port configuration for external port boot mode.

SPI Control Register (SPICTL). Controls the configuration for SPI as master or slave during SPI boot.

SPI DMA Control Register (SPIDMAC). Configures the SPI as receive DMA which generates an interrupt during boot.

SPI Slave Select Control Register (SPIFLGx). Controls the slave select configuration for SPI as master during SPI boot.

SPI Baudrate Register (SPIBAUD). Controls the $SPICLK$ frequency for master mode during boot.

Processor Reset

After power-up, a \overline{RESET} is required to place the processor into a known good state. [Table 17-1](#) shows the differences between a hardware reset (\overline{RESET} pin de-asserted) or a software reset (setting bit 0 in the `SYSCTL` register) and gives an overview of the different reset methods.

Table 17-1. Reset Function Overview

Reset Function	Hardware Reset	Software Reset	Running Reset (ADSP-2137x only)
$\overline{RESETOUT}$ Pin	Output	Output	Input
$\overline{RESETOUT}$ Pulse	4096 CLKIN cycles asserted	2 PCLK cycles asserted	N/A
PLL	Yes	No	No
Core	Yes	Yes	Yes
Internal Memory ¹	No	No	No

Processor Reset

Table 17-1. Reset Function Overview (Cont'd)

Reset Function	Hardware Reset	Software Reset	Running Reset (ADSP-2137x only)
Peripherals	Yes	Yes	Yes (except SDRAM)
Booting	Yes	Yes	No
Power Management	Yes	No	No
Emulation Unit ²	No	No	No

- 1 Internal memory array does not have reset. Only power up/down can change array contents, (or direct read/write by the core or DMA). However, if data exists in shadow FIFOs then that data is reset with any of the above resets. The logic outside the memory array is reset by all of the above three reset types, only the memory array contents remain unchanged.
- 2 There is an independent reset ($\overline{\text{TRST}}$) for the emulation interface. Enhanced Emulation (BTC) related logic is reset by the three resets types (HW Reset, SW Reset, Running Reset). Furthermore, no other part of the emulator is affected by the reset types. $\overline{\text{TRST}}$ resets the whole emulator function, including BTC.

Hardware Reset

All members of the SHARC processor family support the hardware reset controlled with the $\overline{\text{RESET}}$ pin. The de-assertion of this pin enables the PLL and asserting it resets the PLL. In the time it takes the PLL to acquire lock (set to 4096 CLKIN cycles), the processor, internal memory, and the peripherals are held in reset. Upon completion of the 4096 CLKIN cycles, the chip is brought out of reset. This is indicated on the $\overline{\text{RESETOUT}}$ pin for the valid boot modes. [For more information, see “Processor Booting” on page 17-7.](#)

Software Reset

In addition to the hardware reset, there is also support for a software reset, which is asserted by setting bit 0 of the `SYSCTL` register.

Running Reset (ADSP-2137x Only)

When running reset is asserted ($\overline{\text{RESETOUT}}$ pin acting as an input and asserted) and recognized, note the following.

- The core-PLL is NOT reset, and continues to run.
- Internal memory SRAM contents remain unaltered.
- The processor core and peripherals are reset exactly as if a Power-on (hardware) reset is asserted, except:
 - The SDRAM controller continues to run and refresh as programmed.
 - The contents of external SDRAM are unaffected, and retain their values prior to a running reset.
 - A system boot is NOT initiated. Instead, the program counter is cleared and program execution begins from the very first location of program memory (from the reset interrupt vector table).

Running reset allows programs to:

- Execute self-modifying code that has previously overwritten existing code in internal memory.
- Activate an external watchdog in cases where there is a malfunction or exception within a peripheral.
- Perform a context reset of the processor sufficient to restore the state, (in cases where a complete boot is not required).



The `RUNRSTCTL` register is reset only on assertion of a hardware reset, software reset, emulator reset, or by writing to the appropriate bits of the `RUNRSTCTL` register via software.

Processor Reset

For emulation reset, see *SHARC Processor Programming Reference*, “JTAG” chapter.

System Considerations

It is important that an external 10 k Ω pull-up resistor is placed on the $\overline{\text{RESETOUT}}$ pin if it is intended to be used as an input for initiating a running reset on the ADSP-2137x processor's as shown in Figure 17-1.

i It is also extremely important to ensure that an external device, such as a micro controller, does not drive this signal during or after coming out of a power-on or hard-reset.

Figure 17-1 shows the active state of the pin during and after $\overline{\text{RESET}}$. The processor is actively driving this pin as an output. If the system uses an external host or micro controller to control running reset, ensure that the external device waits until the processor driver has been internally disabled (by writing to the RUNRSTCTL register) before actively driving this signal at $\overline{\text{RESET}}$. Connect the $\overline{\text{RESETOUT}}$ pin to an open-drain pin on the host side, or use an external three-state buffer.

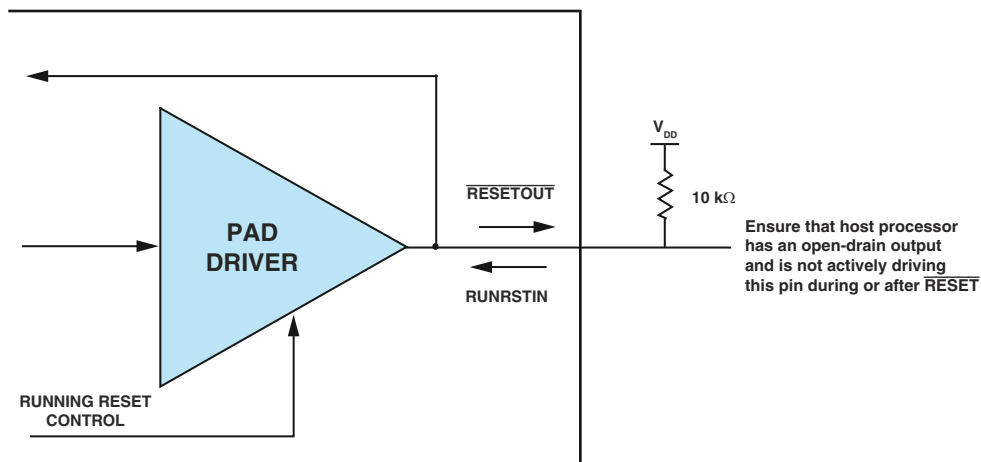

Figure 17-1. RESETOUT Pin Multiplexed with RUNRSTIN

There are several possible methods that can be used to implement running reset. The following illustrates one example of a running reset implementation involving an SHARC processor and a host processor.

External Host

In an AVR (audio-video receiver) system, a host microcontroller may communicate with the ADSP-2137x processor using the serial peripheral interface (SPI) or, if no SPI pins are available on the host device, it can use spare flag I/Os to connect with the SPI of a SHARC as shown in [Figure 17-2](#). In this case, the host implements the SPI protocol on the port pins.

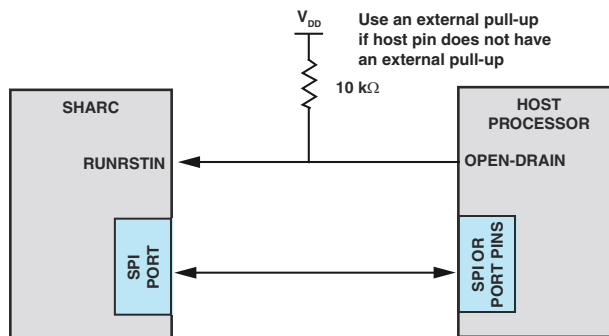

Figure 17-2. Example System Interface With an External Host

Processor Booting

When a processor is initially powered up, its internal SRAM is undefined. Before actual program execution can begin, the application must be loaded from an external non-volatile source such as flash memory or a host processor. This process is known as *bootstrap loading* or *booting* and is automatically performed by the processor after power-up or after a software reset.

Processor Booting

Boot Mechanisms

In order to ensure proper device booting, the following hardware mechanisms are available on the processor.

- Peripheral boot configuration pins ($\overline{\text{BOOT_CFG}}[i]$) configure which peripheral boot stream is activated after power-up.
- Peripheral control and DMA parameter settings define the DMA channel which is started after $\overline{\text{RESETOUT}}$ is asserted based on the boot configuration pins.
- Peripheral interrupt is enabled after reset for the boot peripheral.
- During kernel load the core is put in IDLE. After the interrupt is generated the core jumps to reset location and starts kernel execution.

External Port Booting

The ADSP-2136x and ADSP-2137x processors allow booting through the external port. The boot setting is configured through the BOOTCFG1-0 pins.

The asynchronous memory interface (AMI) supports an 8-bit user boot called AMI boot. Only the $\overline{\text{MST}}$ signal is used for AMI (FLASH/EEPROM) booting. [Table 17-2](#) shows the bit settings for AMI boot. These bits are described in detail in “[AMI Control Registers \(AMICTLx\)](#)” on [page A-21](#).

After $\overline{\text{RESETOUT}}$ de-asserted, the processor starts to drive:

- ADDR23-0
- Chip select $\overline{\text{MST}}$ to the EPROM/FLASH

- \overline{RD} strobe with 23 SDCLK cycle wait states
- Read input data 7–0

i The ACK pin is disabled during external port booting.

The received data streams of 4x8-bit data words are packed by the AMIRX buffer into 32-bit words least significant bit (LSB) first, and passed through the DMA's 6 deep external port buffer DFEPO into the internal memory (Figure 17-3).

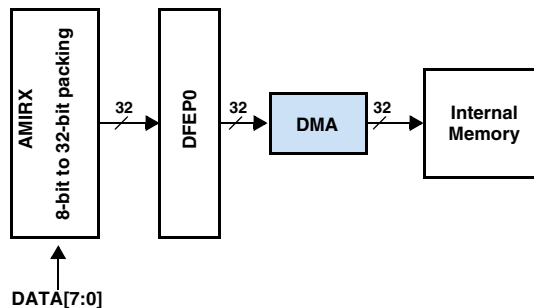

Figure 17-3. External Port Data Packing

The external port DMA channel 0 (DMAC0) is used when downloading the boot kernel information to the processor. At reset, the DMA parameter registers are initialized to the values listed in Table 17-5.

In this configuration, the loader kernel is read via DMA from the FLASH. If the application needs to speed-up read accesses, programs should change the wait states (WS bits, see Table 17-2) in the kernel file. After the kernel is executed, the new wait state settings are applied and processor booting continues.

Processor Booting

Table 17-2. AMICTL1 Boot Settings (0x5C1)

Bit	Name	Setting
0	AMIEN	AMI enable (set = 1)
2–1	BW	Bus width = 8-bit (00)
3	PKDIS	Packing, 8-bit to 32-bit (cleared = 0)
4	MSWF	Most significant word first (cleared = 0)
5	ACKEN	ACK pin disabled (cleared = 0)
10–6	WS	23 wait state cycles = 10111
13–11	HC	Bus hold cycle at the end of write access = 000
16–14	IC	No bus idle cycle = 000
17	FLSH	Buffer holds data (cleared = 0)
20–18	RHC	Read hold cycle at the end of read access = 000
21	PREDIS	Disable Predictive Reads (cleared = 0)

Table 17-3. EPCTL Boot Settings (0xF0)

Bit	Name	Setting
0	B0SD	No SDRAM bank 0 (cleared = 0)
1	B1SD	No SDRAM bank 1 (cleared = 0)
2	B2SD	No SDRAM bank 2 (cleared = 0)
3	B3SD	No SDRAM bank 3 (cleared = 0)
5–4	EPBR	Rotating priority core vs. DMA (11)
7–6	DMAPR	Rotating priority EPDMA ch0 vs. EPDMA ch1 (11)
10–9	FRZDMA	No DMA freezing (00)
14–13	FRZCR	No core freezing (00)
18–15	DATE	No pack mode (0000)

Table 17-4. DMAC0 Boot Settings (0x8001) ADSP-21367/8/9 Processors

Bit	Name	Setting
0	DMAEN	DMA enabled (set = 1)
1	TRAN	Write to internal memory (cleared = 0)
2	CHEN	No DMA chaining (cleared = 0)
3	DLEN	No delay line DMA (cleared = 0)
4	CBEN	No circular DMA (cleared = 0)
5	DFLSH	Disabled (cleared = 0)
6	TFLSH	Disabled (cleared = 0)
8-7	DFS	DMA FIFO empty (0)
10-9	TFS	Tap list FIFO empty (00)
11	DMAS	Status, DMA idle (cleared = 0)
12	CHS	Status (cleared = 0)
13	TLS	Status (cleared = 0)
14	WBS	Status (cleared = 0)
24	EXTS	External access pending (set = 1)

Table 17-5. DMAC0 Boot Settings (0x1000001) ADSP-2137x Processors

Bit	Name	Setting
0	DMAEN	DMA enabled (set = 1)
1	TRAN	Write to internal memory (cleared = 0)
2	CHEN	No DMA chaining (cleared = 0)
3	DLEN	No delay line DMA (cleared = 0)
4	CBEN	No circular DMA (cleared = 0)
5	DFLSH	Disabled (cleared = 0)
7	WRBEN	Disabled (cleared = 0)

Processor Booting

Table 17-5. DMAC0 Boot Settings (0x1000001)
ADSP-2137x Processors (Cont'd)

Bit	Name	Setting
8	OFCEN	Disabled (cleared = 0)
9	TLEN	Disabled (cleared = 0)
12	INTIRT	Disabled (cleared = 0)
17–16	DFS	Status (cleared = 00)
20	DMAS	Status (cleared = 0)
21	CHS	Status (cleared = 0)
22	TLS	Status (cleared = 0)
23	WBS	Status (cleared = 0)
24	EXTS	External access pending (set = 1)
25	DIRS	Status (cleared = 0)

Table 17-6. Parameter Initialization for External Port Boot

Parameter Register	Initialization Value	Comment
IIEP0	IVT_START_ADDR	Start of block 0
IMEP0	0x1	
ICEP0	0x180	384 × 32-bit transfers
EIEP0	0x4000000	External memory select 1 start address
EMEP0	0x1	
ECEP0	0x180	384 × 32-bit transfers

SPI Port Booting

The SHARC processors support booting from a host processor using SPI slave mode (`BOOT_CFG1-0 = 00`). Booting from an SPI flash, SPI PROM, or a host processor via SPI master mode (`BOOT_CFG1-0 = 01`). Both SPI boot modes (master and slave) support 8-, 16-, or 32-bit SPI devices.

-  In both (master and slave) boot modes, the LSBF format is used and SPI mode 3 is selected (clock polarity and clock phase = 1). Both SPI boot modes use default routing with the DPI pin buffers. For more information, see “DPI Default Routing” on page 6-31.

Master Boot Mode

In master boot mode, the processor initiates the booting operation by:

1. Activating the SPICLK signal and asserting the SPI_FLG0_0 signal to the active low state.
2. Writing the read command 0x03 and address 0x00 to the slave device as shown in [Figure 17-5](#).

Master boot mode is used when the processor is booting from an SPI-compatible serial PROM, serial FLASH, or slave host processor. The specifics of booting from these devices are discussed individually.

SPI master booting uses the default bit settings shown in [Table 17-8](#).

Table 17-7. SPIDMAC Master/Slave Boot Settings (0x7)

Bit	Setting	Comment
SPIDEN	Set (= 1)	SPI DMA
SPIRCV	Set (= 1)	SPI receive
INTEN	Set (= 1)	SPI interrupt
SPICHEN	Cleared (= 0)	SPI DMA chaining
FIFOFLSH	Cleared (= 0)	FIFO flush
INTERR	Cleared (= 0)	SPI DMA error interrupts

Processor Booting

Table 17-8. SPICTL Master Boot Settings (0x5D06)

Bit	Setting	Comment
SPIEN	Set (= 1)	SPI enabled
SPIMS	Set (= 1)	Master device
MSBF	Cleared (= 0)	LSB first
WL	10	32-bit SPI receive shift register word length
DMISO	Cleared (= 0)	MISO enabled
SENDZ	Set (= 1)	Send zeros
SPIRCV	Set (= 1)	Receive DMA enabled
CLKPL	Set (= 1)	Active low SPI clock
CPHASE	Set (= 1)	Toggle SPICLK at the beginning of the first bit

The SPI DMA channel is used when downloading the boot kernel information to the processor. At reset, the DMA parameter registers are initialized to the values listed in [Table 17-9](#).

Table 17-9. Parameter Initialization Values for SPI Master Boot

Parameter Register	Initialization Value	Comment
SPIBAUD	0x64	SPICLK = PCLK/100
SPIFLG	0xFE01	SPI_FLG0_O used as slave-select
IISPI	IVT_START_ADDR	Start of block 0
IMSPI	0x1	32-bit data transfers
CSPI	0x180	384 × 32-bit transfers

Master Header Information

The transfer is initiated by the transferring the necessary header information on the interface (consisting of the read opcode and the starting address of the block to be transferred, which is usually all zeros). The read opcode is fixed as 0xC0 (LSBF format) and is 24-bits long. The 8-bits that

are received following the read opcode should be programmed to 0xA5 (see Figure 17-4). If the 8-bits are not programmed to 0xA5 the master boot transfer is aborted. The transfer continues until 384 x 32-bit words have been transferred which may correspond to the loader program (just as in the slave boot mode).

1. Default state of `SPICLK` signal high (out of reset).
2. De-asserting the `SPI_FLG0_0` signal (chip select) to the active low state and toggling the `SPICLK` signal.
3. Reading the read command 0x03 (MSBF format to match the LSBF format) and address 0x00 from the slave device.

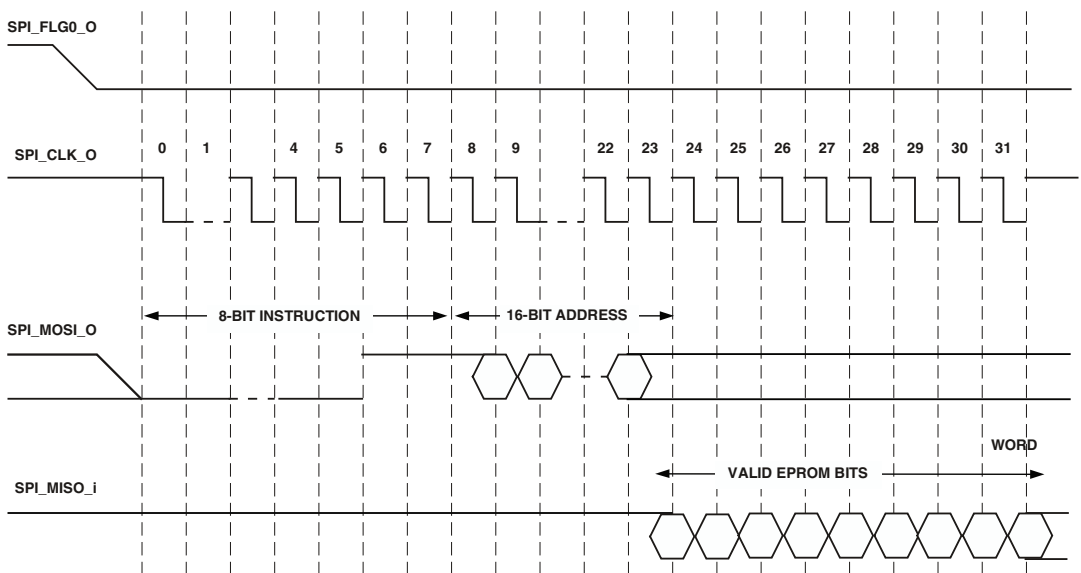

Figure 17-4. SPI Master Mode Booting Using Various Serial Devices



In SPI master boot mode, the `MOSI` pin (DPI pin 02) is driven low during reset.

Processor Booting

Slave Boot Mode

In slave boot mode, the host processor initiates the booting operation by activating the $\overline{\text{SPICLK}}$ signal and asserting the $\overline{\text{SPIDS}}$ signal to the active low state. The 256-word kernel is loaded 32 bits at a time, through the SPI receive shift register (RXSR). To receive 256 instructions (48-bit words) properly, the SPI DMA initially loads a DMA count of $0x180$ (384) 32-bit words, which is equivalent to $0x100$ (256) 48-bit words.

Note that for SPI slave boot $\overline{\text{SPIDS}}$ should only be asserted after $\overline{\text{RESETOUT}}$ has de-asserted.

 When in SPI slave booting mode, the SPI_DS_I input signal is controlled by the SPI host to initiate the boot transfers as shown in [Table 17-10](#).

Since the SPI host initiates the transfers, a handshake between master and slave is required for synchronization. One possible solution is to use the slave's SPI_MISO_0 signal as handshake signal. If a pause is required, the slave transmits zeros or ones to the master. Another solution is to connect this signal to the master's flag input to generate an interrupt for the same purpose.

Table 17-10. SPICTL Slave Boot Settings (0x4D22)

Bit	Setting	Comment
SPIEN	Set (= 1)	SPI enabled
SPIMS	Cleared (= 0)	Slave device
MSBF	Cleared (= 0)	LSB first
WL	10, 32-bit SPI	Receive shift register word length
DMISO	Set (= 1) MISO	MISO disabled
SENDZ	Cleared (= 0)	Send last word
SPIRCV	Set (= 1)	Receive DMA enabled

Table 17-10. SPICTL Slave Boot Settings (0x4D22) (Cont'd)

Bit	Setting	Comment
CLKPL	Set (= 1)	Active low SPI clock
CPHASE	Set (= 1)	Toggle SPICLK at the beginning of the first bit

The SPI DMA channel is used when downloading the boot kernel information to the processor. At reset, the DMA parameter registers are initialized to the values listed in [Table 17-11](#).

Table 17-11. Parameter Initialization for SPI Slave Boot

Parameter Register	Initialization Value	Comment
SPIDMAC	0x0000 0007	Enable receive, interrupt on completion
IISPI	IVT_START_ADDR	Start of block 0
IMSPI	0x1	32-bit data transfers
CSPI	0x180	384 × 32-bit transfers

SPI Boot Packing

In all SPI boot modes, the data word size in the shift register is hardwired to 32 bits. Therefore, for 8- or 16-bit devices, data words are packed into the shift register to generate 32-bit words least significant bit (LSB) first, which are then shifted into internal memory. The relationship between the 32-bit words received into the `RXSPI` register and the instructions that need to be placed in internal memory is shown in the following sections.

For more information about 32- and 48-bit internal memory addressing, see the “Memory” chapter in *SHARC Processor Programming Reference*.

As shown in [Figure 17-5](#), two words shift into the 32-bit receive shift register (`RXSR`) before a DMA transfer to internal memory occurs for 16-bit SPI devices. For 8-bit SPI devices, four words shift into the 32-bit receive shift register before a DMA transfer to internal memory occurs.

Processor Booting

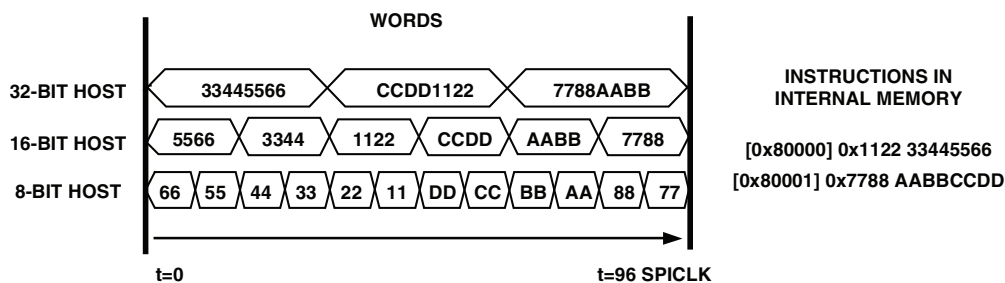

Figure 17-5. Instruction Packing for Different Hosts

When booting, the processors expect to receive words into the `RXSPI` register seamlessly. This means that bits are received continuously without breaks. [For more information, see “Core Transfers” on page 12-19.](#) For different SPI host sizes, the processor expects to receive instructions and data packed in a least significant word (LSW) format.

[Figure 17-5](#) shows how a pair of instructions are packed for SPI booting using a 32-, 16-, and an 8-bit device. These two instructions are received as three 32-bit words.

The following sections examine how data is packed into internal memory during SPI booting for SPI devices with widths of 32, 16, or 8 bits.

32-Bit SPI Packing

Figure 17-6 shows how a 32-bit SPI host packs 48-bit instructions executed at PM addresses PMAddr0 and PMAddr0. The 32-bit word is shifted to internal program memory during the 256-word kernel load.

The following example shows a 48-bit instruction executed:

```
[PMAddr0] 0x112233445566
[PMAddr1] 0x7788AABBCCDD
```

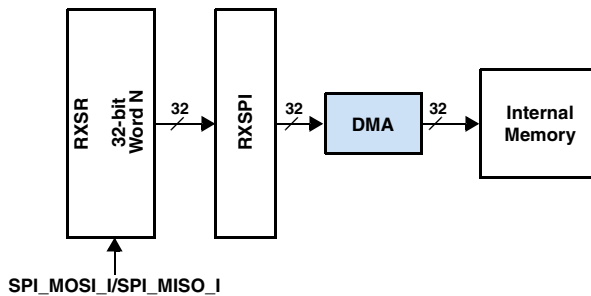

Figure 17-6. 32-Bit SPI Master/Slave Packing

The 32-bit SPI host packs or prearranges the data as:

```
SPI word 1 = 0x33445566
SPI word 2 = 0xCCDD1122
SPI word 3 = 0x7788AABB
```

The initial boot of the 256-word loader kernel requires a 32-bit host to transmit 384×32 -bit words. The SPI DMA count value of 0x180 is equal to 384 words.

Processor Booting

16-Bit SPI Packing

Figure 17-7 shows how a 16-bit SPI host packs 48-bit instructions at PM addresses PMAddr0 and PMAddr1. For 16-bit hosts, two 16-bit words are packed into the shift register to generate a 32-bit word. The 32-bit word shifts to internal program memory during the kernel load.

The following code shows a 48-bit instruction executed.

```
[PMAddr0] 0x112233445566  
[PMAddr1] 0x7788AABBCCDD
```

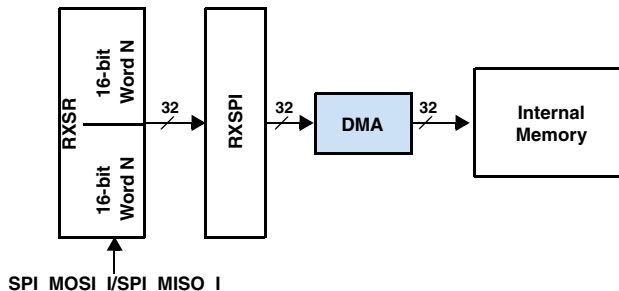

Figure 17-7. 16-Bit SPI Master/Slave Packing

The 16-bit SPI host packs or prearranges the data as:

```
SPI word 1 = 0x5566  
SPI word 2 = 0x3344  
SPI word 3 = 0x1122  
SPI word 4 = 0xCCDD  
SPI word 5 = 0xAABB  
SPI word 6 = 0x7788
```

The initial boot of the 256-word loader kernel requires a 16-bit host to transmit 768 16-bit words. Two packed 16-bit words comprise the 32-bit word. The SPI DMA count value of 0x180 is equivalent to 384 words. Therefore, the total number of 16-bit words loaded is 768.

8-Bit SPI Packing

Figure 17-8 shows how an 8-bit SPI host packs 48-bit instructions executed at PM addresses PMAddr0 and PMAddr1. For 8-bit hosts, four 8-bit words pack into the shift register to generate a 32-bit word. The 32-bit word shifts to internal program memory during the load of the 256-instruction word kernel.

The following code shows a 48-bit instruction executed:

```
[PMAddr0] 0x112233445566
[PMAddr1] 0x7788AABBCDD
```

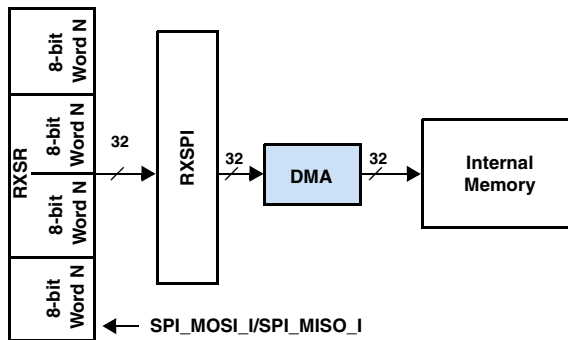

Figure 17-8. 8-Bit SPI Slave Packing

The 8-bit SPI host packs or prearranges the data as:

SPI word 1 =	0x66	SPI word 7 =	0xDD
SPI word 2 =	0x55	SPI word 8 =	0xCC
SPI word 3 =	0x44	SPI word 9 =	0xBB
SPI word 4 =	0x33	SPI word 10 =	0xAA
SPI word 5 =	0x22	SPI word 11 =	0x88
SPI word 6 =	0x11	SPI word 12 =	0x77

The initial boot of the 256-word loader kernel requires an 8-bit host to transmit 1536 x 8-bit words. The SPI DMA count value of 0x180 is equal

Processor Booting

to 384 words. Since one 32-bit word is created from four packed 8-bit words, the total number of 8-bit words transmitted is 1536.

Kernel Boot Time

This section illustrates the minimum required booting time for the kernels (provided by the tools). There are five timing windows which describe together the entire boot process shown in the list below and [Table 17-12](#).

1. $\overline{\text{RESET}}$ to $\overline{\text{RESETOUT}}$ (core is in reset)
2. $\overline{\text{RESETOUT}}$ to chip select boot source (activate the boot DMA)
3. Load Kernel DMA (256 words)
4. Load application (user dependent)
5. Load IVT (256 words)

Table 17-12. Boot Times

Boot Mode	$\overline{\text{RESET}}$ to $\overline{\text{RESETOUT}}$	$\overline{\text{RESETOUT}}$ to Boot Chip Select	Kernel DMA (256 Words)	Comment
SPI Master	4096 CLKIN	1 PCLK	$(I/O \times PCLK \div 100 + 4 \times PCLK) \times N$	N=384, 768 or 1536 for I/O = 32, 16 or 8
SPI Slave	4096 CLKIN	Host drives signal	$(I/O \times PCLK \div 100 + 2 \times PCLK) \times N$	N=384, 768 or 1536 for I/O = 32, 16 or 8
External Port	4096 CLKIN	5 PCLK	$25 \times PCLK \times 1536$	

The complete time for booting can be estimated by adding all 5 timing windows. Loading Kernel and Loading IVT both have the same size, however the default access time (wait states) for the IVT loading can be changed in the kernel by the user.

ROM Booting

There are two access types (modes) available for ROM booting: secured and non secured modes which are described below.

Secured ROM (hardware security switch = 1. In this mode:

- `BOOTCFG1-0` pins are ignored.
- Emulation is enabled only when the user enters a valid key.
- IIVT is placed into the internal ROM. It can be changed to the internal RAM by setting IIVT bit of `SYSCTL` register.
- Code always executes from internal ROM.

Non Secured ROM (hardware security switch = 0. In this mode:

- `BOOTCFG1-0` pins select the booting modes.
- Emulation is always enabled
- IIVT is placed into the internal RAM except for the case where `BOOTCFG1-0 = 11`.

Programming Model

This section describes the operation of the boot process. This process is accomplished using the default loader kernel (Visual DSP Tools) to generate the boot stream. For more details, refer to the loader source files.

Running Reset

Using the SPI protocol with additional control words and commands, running reset can become an addition command from the host or from the processor as described in the following procedure.

1. The host initiates a running reset by informing the processor over the command interface.
2. The processor receives the command and completes any unfinished work which may also include writing to the `RUNRSTCTL` register.
3. Wait at least 5 `CCLK` cycles to ensure that the pin is configured as an input.
4. When the processor is ready to accept the running reset, it signals the host over the command interface.
5. The host drives the running reset input into the processor.

Running The Boot Kernel

The following sections provide information on the use of the boot kernel with the SHARC processors.

Loading the Boot Kernel Using DMA

1. At reset, the processor is hardwired (using the boot configuration pins) to load 256 x 48-bit instruction words via a DMA starting at `IVT_START_ADDRESS`.
2. The sequencer is put into IDLE until the boot interrupt occurs.

Executing the Boot Kernel

1. The DMA completes (counter zero) and the interrupt associated with the peripheral that the processor is booting from is activated.
2. The processor jumps to the applicable interrupt vector location and executes the RTI instruction located there (only).



If using your own loader kernel, you must ensure that the RTI instruction points to the IVT location of the boot peripheral.

Loading the Application

1. Once the kernel is executed (initialization of some core and external peripheral registers and such as AMI or SDRAM), the kernel prepares a DMA for further data.
2. After this the DMA starts and the core waits in IDLE until an interrupt is generated.
3. The kernel then reads the header data from a memory scratch location, decodes the header and configures a loop which loads all of the header's corresponding data.
4. Step 3 is repeated until all headers are executed.

Loading the Application's Interrupt Vector Table

1. The last header is recognized by the kernel indicating that booting has nearly finished.
2. The kernel prepares a 256 x 48-word DMA starting at `IVT_START_ADDRESS`.

Programming Model

This overrides the kernel with the application's IVT. However, the application needs to temporarily include the RTI instruction at the peripheral interrupt address, allowing a return from interrupt. Moreover, the last instruction in the final routine is a jump (db) including an IDLE.

3. The RTI instruction overrides the IVT address where user code is stored.

 While both DMA types (“[Loading the Boot Kernel Using DMA](#)” and “[Loading the Application's Interrupt Vector Table](#)”) seem similar, loading the kernel is accomplished using hardware while loading the IVT is accomplished using software.

 It is very important to match the dedicated kernel to the dedicated boot type (for example SPI kernel and SPI boot type) in the elf-loader property page. If this is not done, the RTI instruction (in “[Loading the Application's Interrupt Vector Table](#)”) will not be placed at the correct address. This causes execution errors.

Starting Program Execution

The processed interrupt returns the sequencer to the reset location by performing the two following steps.

1. Overriding the RTI instruction with user code.
2. Starting program execution from the reset location.

For other details relating to processor booting, see the boot loader source files that ship with the CrossCore or VisualDSP++ tools.

Memory Aliasing in Internal Memory

The boot loader takes advantage of memory aliasing which is essential to understand the boot mechanisms. For information on memory aliasing, see the “Memory” chapter in *SHARC Processor Programming Reference*.

During the boot process, word packing (for example 8 to 32-bit) is performed over the SPI. In other words, the kernel is not loaded directly with 256 x 48-bit words, instead it is loaded with 384 x 32-bit ‘packed words’ (2-column access). The same physical memory for instruction boot is loaded via DMA in normal word (NW) 2 column. However, after booting the same physical memory region is fetched by the sequencer in NW 3-column. For example the loader kernel itself has a NW 2 columns count of $256 \times 3/2 = 384$ words but the kernel is executed with 256 instruction fetches.

Note that the interrupt vector table addresses are defined as:
 IVT_Start_Addr = 0x90000 and IVT_End_Addr = 0x900FF.

Pin Multiplexing

The SHARC processors provide extensive functionality using a low pin count (reducing system cost). They do this through extensive use of pin multiplexing. The following sections provide information on this feature. Although the processors have the efficient and flexible DAI and DPI routing options, there are also I/O pins which are shared by some peripherals. The following sections discuss these options.

Core FLAG Pins Multiplexing

This module also includes the multiplexers of the FLAG0-3 pins shown in [Figure 17-9](#). The FLAG0-2 pins can act as core FLAGS0-2 or $\overline{TRQ0-2}$, or a memory select $\overline{MS2}$ (FLAG2 pin) and the FLAG3 pin can act as a core FLAG3 or the TMREXP signal of the core timer or as a memory select $\overline{MS3}$.

 Flag pins (FLG3-0) are connected as input after reset.

If more than four flags are required, they can multiplexed using the external port pins in the SYSCTL register or the DPI pins in the DPI registers.

Pin Multiplexing

For a detailed flag description refer to the *SHARC Processor Programming Reference*. [Table 17-13](#) provides information on FLAG function based on the settings of the memory select enable, the flag timer expired and the FLAG2 interrupt bits in the system control register.

Table 17-13. Flag 3–2 Truth Table (SYSCTL Register)

MSEN Bit	TMREXPEN Bit	IRQ2EN Bit	FLAG3 Function	FLAG2 Function
0	0	0	FLAG3	FLAG2
0	0	1	FLAG3	$\overline{\text{IRQ2}}$
0	1	0	TMREXP	FLAG2
0	1	1	TMREXP	$\overline{\text{IRQ2}}$
1	0	0	$\overline{\text{MS3}}$	$\overline{\text{MS2}}$

Backward Compatibility

The FLAG/ $\overline{\text{IRQ}}$ (0, 1, 2, 3) pins retain their old functionality and programming. No changes are required for old programs. The select lines for multiplexes are controlled by the SYSCTL register. [For more information, see “System Control Register \(SYSCTL\)” on page A-4.](#)

External Port Pin Multiplexing

Various peripherals use the external port for off-chip communication. These peripherals use multiplexed I/O and have the (functions) shown:

- External Port (AMI/SDRAM)
- PDAP (input)
- FLAGs (I/O)
- PWM channels (output)

Multiplexed External Port Pins

The EPDATA31-0 pins are used to multiplex the external port interface with other peripherals. [Table 17-14](#) provides the pin settings.

Table 17-14. EPDATA Truth Table (SYSCTL Register)

EPDATA	DATA31-16 ¹	DATA15-8	DATA7-0
000	EPDATA32-0 (default at RESET)		
001	FLAGS/PWM15-0 ^{1, 2}	EPDATA15-0	
010	FLAGS/PWM15-0 ^{1, 2}	FLAGS15-8	EPDATA7-0
011	FLAGS/PWM15-0 ^{1, 2}	FLAGS15-0	
100	PDAP (DATA + CTRL) ¹		EPDATA7-0
101	PDAP (DATA + CTRL) ¹		FLAGS7-0
110	Reserved		
111	Three-state all pins		

¹ Not available on the ADSP-21375 processors.

² These signals can be FLAGS or PWM or a mix of both. However, they can be selected only in groups of four. Their function is determined by the control signals PWMxEN.

[Table 17-14](#) shows the following options.

- FLAGS can be mapped to any of the 32 EPDATA pins.
- PDAP data/control can be completely moved to EPDATA pins (instead of DAI pins).
- PDAP, PWM signals can be mapped only to the upper bits of the EPDATA pins.
- FLAGS/PWM can be mapped (in groups of four) to any of the upper 31-16 EPDATA pins.

Pin Multiplexing

Backward Compatibility

Since these processor's have an external port, the entire external port multiplexing has changed compared to parallel port multiplexing on previous SHARC processors. Differences occur in that the FLAG15-4 pins are now routed via the DPI unit. The FLAG15-10 inputs to the DAI MISCA/B buffers have also been removed.

Parallel Connection of External Port and DPI Flag Pins

The various external port multiplexing (shown in [Figure 17-9 on page 17-31](#)) and DPI routing options allow situations where the flag direction paths from the core to the external port or DPI pins operates in parallel. Note that:

For FLAG3-0

- In output mode, if the same flag is mapped to both external port pins and FLAG3-0 pins, then the output is driven to both pins.
- In input mode, if the same flag is mapped to both external port pins and FLAG3-0 pins, then the input from external port pins has priority.

For FLAG15-4

- In output mode, if the same flag is mapped to both external port pins and DPI pins, then the output is driven from both pins.
- In input mode, if the same flag is mapped to both external port pins and DPI pins, then the input from the external port pins has priority.

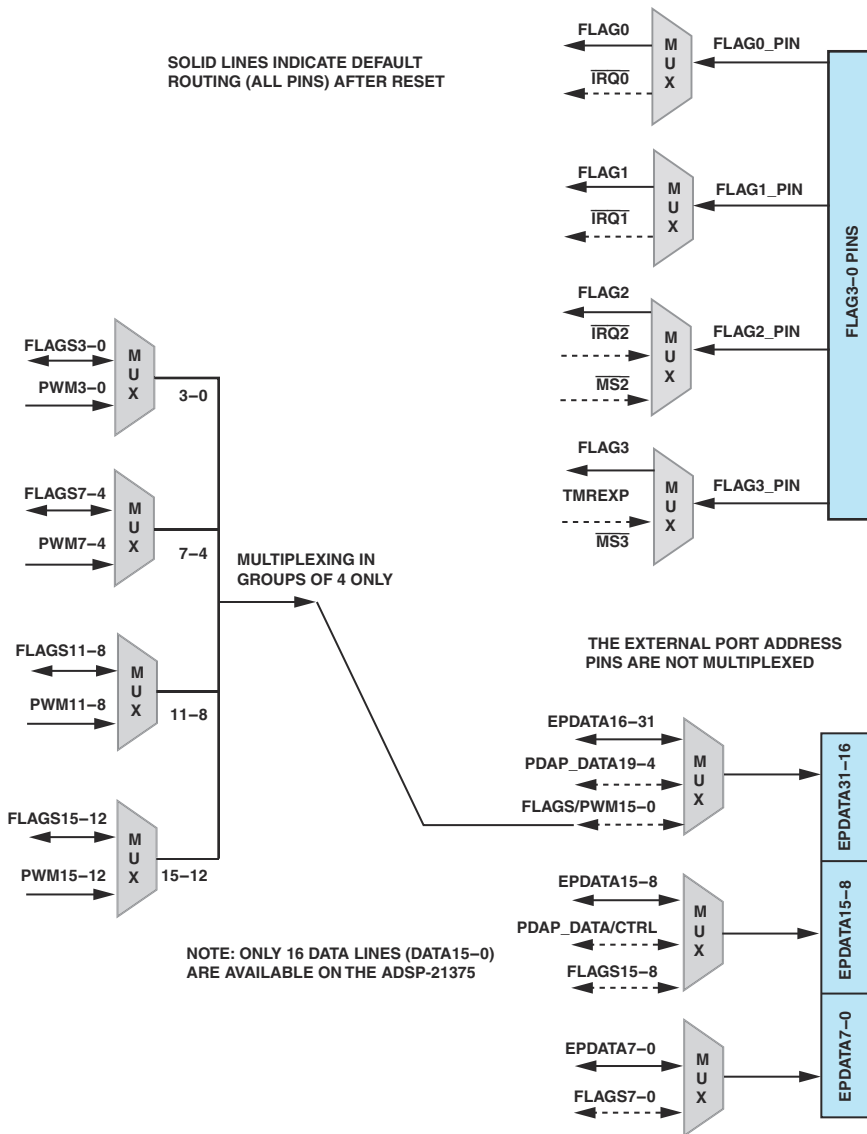

Figure 17-9. Pin Multiplexing

Pin Multiplexing

External Port Multiplexing Examples

The $\text{FLAG}/\overline{\text{TRQ}}$ (0, 1, 2, 3) and DATA_{31-0} pins are completely independent. Any mode of programming in one group does not affect the other.

Case 1 (EPDATA = 000)

If 32-bit external SDRAM/FLASH/SRAM is used, then all data pins should be connected to the memory device so that no other functionality can be programmed in the data pins. In this case, use $\text{EPDATA} = 000$. If flags are required, they can be moved to the DPI SRU2.

Case 2 (EPDATA = 001)

If 16-bit external SDRAM/FLASH/SRAM is used, and if 16 flag inputs are required, then use $\text{EPDATA} = 001$. Since 16 flags are required, set $\text{PWMxEN} = 0000$. The flag input mode is specified in the FLAGS register.

Case 3 (EPDATA = 001)

If 16-bit external SDRAM/FLASH/SRAM is used, and if 8 flag outputs and 8 PWM outputs are required, then use $\text{EPDATA} = 001$. Since 8 flags and PWM outputs are required, set $\text{PWMxENL} = 1100$. (In this mode, DATA_{31-24} are PWM outputs and DATA_{23-16} are flag outputs.) The flag output mode is specified in FLAGS register.

Case 4 (EPDATA = 010)

If 8-bit external SDRAM/FLASH/SRAM is used, and if 8 flag inputs, 8 flag outputs, and 8 PWM outputs are required, then use $\text{EPDATA} = 010$. Since 16 flags are required, then all flags on DATA_{31-16} are programmed. This means that there are not enough pins left for the PWM outputs (DATA_{15-8}). Therefore, program the PWM outputs on DATA_{23-16} and program the FLAGS on DATA_{31-24} and DATA_{15-8} . Set $\text{PWMxEN} = 0011$. The flag I/O direction is specified in the FLAGS register.

Case 5 (EPDATA = 110)

If no external memory is used, and if the PDAP data lines are connected to DATA pins, and if 8 flags are required, then use EPDATA = 110. Connect the PADP control lines to the DATA pins, and program the flag direction in the FLAGS register.

High Frequency Design

Because the processor must be able to operate at very high clock frequencies, signal integrity and noise problems must be considered for circuit board design and layout. The following sections discuss these topics and suggest various techniques to use when designing and debugging target systems.

Circuit Board Design

The processor is a CMOS device. It has input conditioning circuits which simplify system design by filtering or latching input signals to reduce susceptibility to glitches or reflections.

The following sections describe why these circuits are needed and their effect on input signals.

Clock Input Specifications and Jitter

The clock input signal must be free of ringing and jitter. Clock jitter can easily be introduced into a system where more than one clock frequency exists. Jitter should be kept to an absolute minimum. High frequency jitter on the clock to the processor may result in abbreviated internal cycles.

Keep the portions of the system that operate at different frequencies as physically separate as possible. The clock supplied to the processor must

High Frequency Design

have a maximum rise time and must meet or exceed a high and low voltage of V_{IH} and V_{IL} , respectively.

Refer to the appropriate product data sheet for exact specifications.

RESETOUT

Circuit boards should have a test pad for the $\overline{\text{RESETOUT}}$ pin. This pin can be used as handshake signal for booting or as clock out (CLKIN frequency) for a debug aid to verify the processor is active and running.

Input Pin Hysteresis

Hysteresis (shown in [Figure 17-10](#)) is used on all SHARC input signals. Hysteresis causes the switching point of the input inverter to be slightly above 1.4 V (V_T) for a rising edge (V_{T+}) and slightly below 1.4 V for a falling edge (V_{T-}). The value of the hysteresis is approximately ± 100 mV. The hysteresis is intended to prevent multiple triggering of signals that are allowed to rise slowly, as might be expected for example on a reset line with a delay implemented by an RC input circuit. Hysteresis is not used to reduce the effect of ringing on processor input signals with fast edges, because the amount of hysteresis that can be used on a CMOS chip is too small to make a difference. The small amount of hysteresis allowed is due to restrictions on the tolerance of the V_{IL} and V_{IH} TTL input levels under worst-case conditions.

Refer to the appropriate product data sheet for exact specifications.

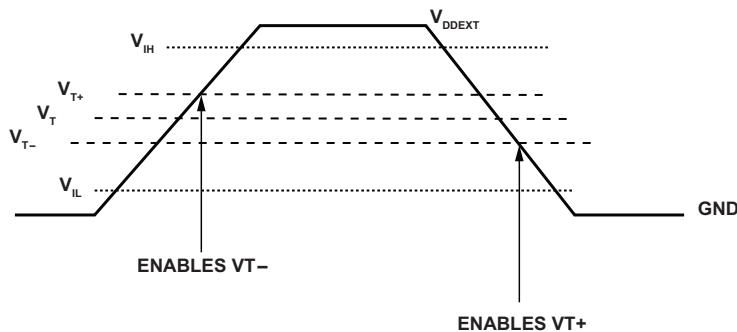

Figure 17-10. Input Pin Hysteresis

Pull-Up/Pull-Down Resistors

The pin descriptions in the product-specific data sheets includes recommendations on how to handle pins on interfaces that are disabled or for unused pins on interfaces that are enabled. Generally, if internal pull-ups (PU) or pull-downs (PD) are included, the pins can be left floating. Any pin that is output only can always be left floating.

If internal pull-ups and pull-downs are not included or disabled, pins can normally still be floated with no functional issues for the device. However, this may allow additional leakage current.

Although the recommendations normally indicate using external pull-up resistors, pull-down resistors can also be used. The leakage is the same whether pull-ups or pull-downs are used. Connections directly to power or ground can be used only if the pins can be guaranteed to never be configured as outputs.

Memory Select Pins

When the multiplexed memory selects, $\overline{MS3-2}$, are enabled as outputs, the pull-up resistors are automatically enabled. For example, if $\overline{MS2}$ and $\overline{MS3}$ are used, they require that stronger external pull-up resistors are

High Frequency Design

connected. For more details on resistor values, refer to the product-specific data sheet.

Edge Triggered I/O

It is recommended that GPIO output pins that are used to drive an edge-sensitive signal like an interrupt ($\overline{\text{IRQ2-0}}$, DAI/DPI pins) have series termination resistors to prevent glitches on the signal transitions. It is equally important that GPIO inputs that are edge-sensitive be driven from sources that have series termination resistors. The values for the series resistor can be determined by simulating with the IBIS models. These models can be found on the Analog Devices web site.

Asynchronous Inputs

The processor has several asynchronous inputs such as $\overline{\text{IRQ2-0}}$, FLAG3-0, ACK and the DAI/DPI pins and reset inputs $\overline{\text{RESET}}$, $\overline{\text{TRST}}$, running reset which can be asserted in arbitrary phase to the reference clocks. The processor synchronizes the reset inputs to the CLKIN input while the peripheral inputs are synchronized to the PCLK prior to recognizing them.

The delay associated with recognition is called the synchronization delay. Any asynchronous input must be valid prior to the recognition point in a particular cycle. If an input does not meet the setup time on a given cycle, it may be recognized in the current cycle or during the next cycle.

To ensure recognition of an asynchronous input, it must be asserted for at least one PCLK cycle plus setup and hold time, except for $\overline{\text{RESET}}$, which must be asserted for at least four CLKIN processor cycles. The minimum time prior to recognition (the setup and hold time) is specified in the appropriate product data sheet.

Decoupling and Grounding

Designs should use an absolute minimum of four bulk capacitors (2 x 10 μ F for VDDINT and 2 x 10 μ F for VDDEXT). Furthermore a minimum of 20 x 10nF ceramic bypass capacitors (5 per chip corner for VDDINT and VDDEXT).

Capacitors type, value and placement is critical—especially for floating point computations, which draw more power. If the bulk/bypass capacitors are insufficient, the power rails may drop, causing errors. Therefore sufficient capacitor backup is important.

Circuit Board Layout

This section gives recommendations to physical layouts for high speed designs.

- Place the oscillator close to the destination.
- Place the series termination close to the clock source.

For trace routing:

- Place a GND plane below the oscillator and buffer.
- Place a solid GND reference plane under the clock traces.
- Do not route the digital signals near or under the clock sources.

Other Recommendations and Suggestions

- Use more than one ground plane on the PCB to reduce crosstalk. Be sure to use lots of vias between the ground planes. One V_{DD} plane for each supply is sufficient. These planes should be in the center of the PCB.

High Frequency Design

- To reduce crosstalk, keep critical signals such as clocks, strobes, and bus requests on a signal layer next to a ground plane away from, or lay out these signals perpendicular to, other non-critical signals.
- If possible, position the processors on both sides of the board to reduce area and distances.
- To allow better control of impedance and delay, and to reduce crosstalk, design for lower transmission line impedances.
- Experiment with the board and isolate crosstalk and noise issues from reflection issues. This can be done by driving a signal wire from a pulse generator and studying the reflections while other components and signals are passive.

The capacitors should be placed close to the package as shown in [Figure 17-11](#). The decoupling capacitors should be tied directly to the power and ground planes with vias that touch their solder pads. Surface-mount capacitors are recommended because of their lower series inductances (ESL) and higher series resonant frequencies.

Connect the power and ground planes to the processor's power supply pins directly with vias—do not use traces. The ground planes should not be densely perforated with vias or traces as this reduces their effectiveness. In addition, there should be several large tantalum capacitors on the board.



Designs can use either bypass placement case shown in [Figure 17-11](#), or combinations of the two. Designs should try to minimize signal feedthroughs that perforate the ground plane.

**BYPASS CAPACITORS ON NON-COMPONENT
(BOTTOM) SIDE OF BOARD, BENEATH DSP PACKAGE**

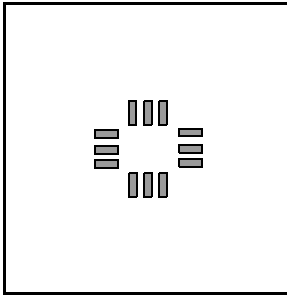

**BYPASS CAPACITORS ON COMPONENT
(TOP) SIDE OF BOARD, AROUND DSP PACKAGE**

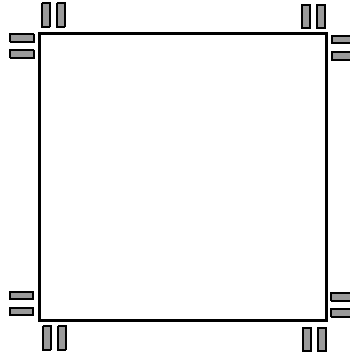

Figure 17-11. Bypass Capacitor Placement

EZ-KIT Lite Schematics

The EZ-KIT Lite® evaluation system schematics are a good starting reference. Because the EZ-KIT Lite board is for evaluation and development, extra circuitry is provided in some cases. Read the EZ-KIT Lite board schematic carefully, because sometimes a component is not populated and sometimes it has been added to make it easier to access. The design database for the SHARC processor EZ-KIT Lite boards is available online and contains all of the electronic information required for design, layout, fabrication, and assembly:

ftp://ftp.analog.com/pub/tools/Hardware/Reference_Designs

Oscilloscope Probes

When making high speed measurements, be sure to use a “bayonet” type or similarly short (< 0.5 inch) ground clip, attached to the tip of the oscilloscope probe. The probe should be a low capacitance active probe with 1 pF or less of loading. The use of a standard ground clip with four inches of ground lead causes ringing to be seen on the displayed trace and makes the signal appear to have excessive overshoot and undershoot.

High Frequency Design

A 1 GHz or better sampling oscilloscope is needed to see the signals accurately.

Recommended Reading

The text *High-Speed Digital Design: A Handbook of Black Magic* is recommended for further reading. This book is a technical reference that covers the problems encountered in state-of-the-art, high frequency digital circuit design. It is also an excellent source of information and practical ideas. Topics covered in the book include:

- High-Speed Properties of Logic Gates
- Measurement Techniques
- Transmission Lines
- Ground Planes and Layer Stacking
- Terminations
- Vias
- Power Systems
- Connectors
- Ribbon Cables
- Clock Distribution
- Clock Oscillators

High-Speed Digital Design: A Handbook of Black Magic, Johnson & Graham, Prentice Hall, Inc., ISBN 0-13-395724-1.

High-Speed Signal Propagation: Advanced Black Magic, Johnson & Graham, Prentice Hall, Inc., ISBN 0-13-084408-X.

System Components

This section provides some recommendations for other components to use when designing a system for your ADSP-2136x and ADSP-2137x processor.

Supervisory Circuits

It is important that a processor (or programmable device) have a reliable active $\overline{\text{RESET}}$ that is released once the power supplies and internal clock circuits have stabilized. The $\overline{\text{RESET}}$ signal should not only offer a suitable delay, but it should also have a clean monotonic edge. Analog Devices has a range of microprocessor supervisory ICs with different features. Features include one or more of the following.

- Power-up reset
- Optional manual reset input
- Power low monitor
- Backup battery switching

The part number series for reset and supervisory circuits from Analog Devices are as follows.

- ADM69x
- ADM70x
- ADM80x
- ADM1232
- ADM181x
- ADM869x

System Components

A simple power-up reset circuit is shown in [Figure 17-12](#) using the ADM809-RART reset generator. The ADM809 provides an active low $\overline{\text{RESET}}$ signal whenever the supply voltage is below 2.63 V. At power-up, a 240 ms active reset delay is generated to give the power supplies and oscillators time to stabilize.

Another part, the ADM706TAR, provides power on $\overline{\text{RESET}}$ and optional manual $\overline{\text{RESET}}$. It allows designers to create a more complete supervisory circuit that monitors the supply voltage. Monitoring the supply voltage allows the system to initiate an orderly shutdown in the event of power failure. The ADM706TAR also allows designers to create a watchdog timer that monitors for software failure. This part is available in an 8-lead SOIC package. [Figure 17-13](#) shows a typical application circuit using the ADM706TAR.

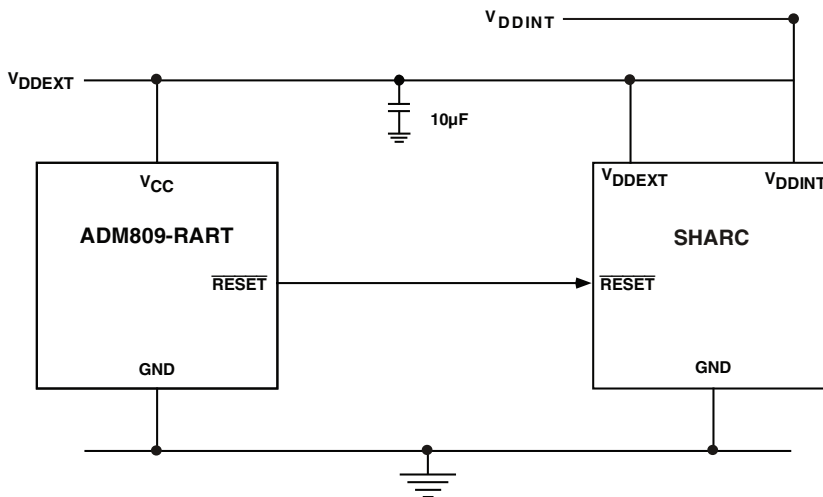

Figure 17-12. Simple Reset Generator

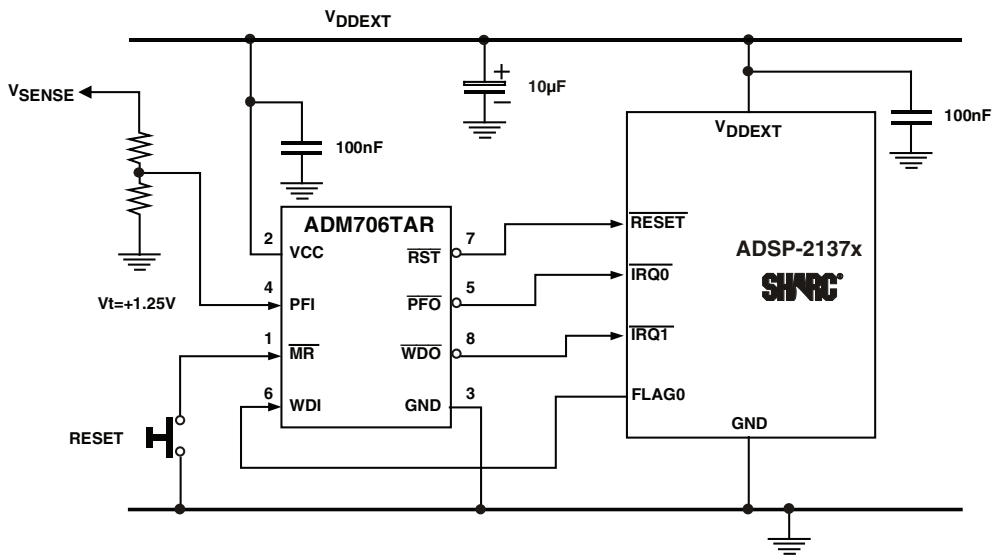

Figure 17-13. Reset Generator and Power Supply Monitor

Definition of Terms

Booting

When a processor is initially powered up, its internal SRAM and many other registers are undefined. Before actual program execution can begin, the application must be loaded from an external non-volatile source such as flash memory or a host processor. This process is known as bootstrap loading or booting and is automatically performed by the processor after power-up or after a software reset.

Boot Kernel

The boot kernel is an executable file which schedules the entire boot process. The temporary location of the kernel resides in the processor's Interrupt vector location (IVT). The IVT typically has a maximum size of 256 x 48 words. After booting, the kernel overwrites this area.

Definition of Terms

These kernel files (DXE, ASM) are supplied with the CrossCore or VisualDSP++ development tools for all boot modes. For more information on the kernels, refer to the tools documentation

Boot Master/Slave

How a processor boots is dependent on the peripheral used. See [“Processor Booting” on page 17-7](#).

Boot Modes

The boot mode is identified by the `BOOT_CFG1-0` pins that are used in the boot process.

No Boot Mode

In this mode, the processor does not boot. Instead, it starts fetching instructions directly from external memory. The SHARC processors do not support this mode.

ROM Boot Mode

For `BOOT_CFG1-0` pins = 11, the processor boots from internal ROM. Only specific versions of the processors support this mode.

A REGISTERS REFERENCE

The SHARC processors have general-purpose and dedicated registers in each of their functional blocks. The register reference information for each functional block includes bit definitions, initialization values, and memory-mapped addresses (for I/O processor registers). Note that this appendix only contains information for the control and or status registers. The peripheral's DMA parameter IOP registers (for example address, modify, count) are described in [Chapter 2, I/O Processor](#).

- [“Overview” on page A-2](#)
- [“System and Power Management Registers” on page A-4](#)
- [“Peripheral Registers” on page A-11](#)
- [“DAI Signal Routing Unit Registers” on page A-40](#)
- [“Peripherals Routed Through the DAI” on page A-70](#)
- [“DPI Signal Routing Unit Registers” on page A-129](#)
- [“Peripherals Routed Through the DPI” on page A-144](#)
- [“Register Listing” on page A-186](#)

When writing programs, it is often necessary to set, clear, or test bits in the processor's registers. While these bit operations can all be done by referring to the bit's location within a register or (for some operations) the register's address with a hexadecimal number, it is much easier to use symbols that correspond to the bit's or register's name. For convenience and consistency, Analog Devices supplies a header file that provides these bit and registers definitions. CrossCore Embedded Studio provides

Overview

processor-specific header files in the `SHARC/include` directory. An `#include` file is provided with VisualDSP++ tools and can be found in the `VisualDSP/21367/include` directory.

Overview

The I/O processor's registers are accessible as part of the processor's memory map. [“Register Listing” on page A-186](#) lists the I/O processor's memory-mapped registers and provides a brief description of each register.

Since the I/O processor registers are memory-mapped, the processor's architecture does not allow programs to directly transfer data between these registers and other memory locations, except as part of a DMA operation. To read or write I/O processor registers, programs must use the processor core registers.

The register names for I/O processor registers are not part of the processor's assembly syntax. To ease access to these registers, programs should use the header file containing the registers' symbolic names and addresses.

Register Diagram Conventions

The register drawings (figures) in this appendix provide “at-a-glance” information about specific registers. They are designed to give experienced users basic information about a register. When using these registers, the following should be noted.

- In cases where there are multiple registers that have the same bits (such as serial ports), one register drawing is shown and the names and addresses of the other registers are simply listed. Also, depending on peripheral (such as ASRC), if two different ASRC ports are programmed in the same register, one peripheral is defined with a *x* the other with a *y* index.

- The bit descriptions in the figures are intentionally brief, containing only the bit mnemonic, location, and function. More detailed information can be found in the tables that follow the register drawings and in the chapters that describe the particular module.
- Shaded bits are reserved.
- The CrossCore or VisualDSP++ tools suite contains the complete listing of registers in a header file, `def21367.h`.
- [“Register Listing” on page A-186](#) provides a complete list of user accessible registers, their addresses, and their state at reset.

Bit Types and Settings

There are several bit types used in SHARC registers. These are described in [Table A-1](#). In general, control register bits are read-write (RW) and status register bits are read-only (RO). In exceptional cases, bit types are shown in the “Bit” column in parenthesis (for example a RO bit is used in a control register or for write-one-to-clear (W1C) bits).

Also note that the setting after reset (default setting) of most bits is 0 (cleared). In cases where this is not true, this is shown in the “Description” column in parenthesis.

Table A-1. Bit Type Usage

Bit Type	Description	Usage
RW	Read-Write	RW bits are used primarily in control registers and DMA parameter and count registers.
RO	Read-Only	RO bits are used primarily in status registers and Shadow registers/buffers for debug aid.
ROC	Read-Only-to-Clear	ROC bits are used to clear receive buffer status bits. These bits are also used on the DAI/DPI interrupt controllers. These bits are sticky and their status is only cleared after a read.

System and Power Management Registers

Table A-1. Bit Type Usage (Cont'd)

Bit Type	Description	Usage
WO	Write-Only	WO bits are used primarily in control/status register to trigger events like self-refresh or power-up sequence for SDRAM. Note that these bit type always read zero
WOC	Write-Only-to-Clear	WOC bits are used primarily in control/status register to flush data FIFOs and to clear its status bits.
W1C	Write-1-to-Clear	W1C bits are sticky bits used primarily in status registers during interrupt acknowledge for PWM and timers. These bits are sticky and their status is only cleared after a write.

 Many registers have reserved bits. When writing to a register, programs may only clear (write zero to) the register's reserved bits.

System and Power Management Registers

The registers described in the following sections are used to control system wide operations and power management.

System Control Register (SYSCTL)

The SYSCTL register configures memory use, interrupts, and many aspects of pin multiplexing. (For more information, see [“Pin Multiplexing” on page 17-27.](#)) Bit descriptions for this register are shown in [Figure A-1](#) and described in [Table A-2](#).

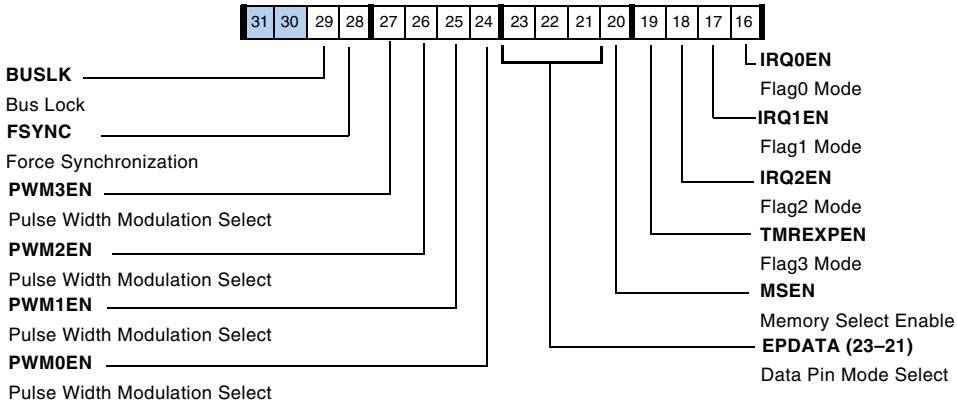

Figure A-1. SYSCTL Register

Table A-2. SYSCTL Register Bit Descriptions (RW)

Bit	Name	Description
15–0		The bits are used for controlling core function. Refer to <i>SHARC Processor Programming Reference</i> .
16	IRQ0EN	Flag0 Interrupt Mode. 0 = FLAG0 pin is a general-purpose I/O pin. Permits core writes. 1 = FLAG0 pin is allocated to interrupt request $\overline{IRQ0}$.
17	IRQ1EN	Flag1 Interrupt Mode. 0 = FLAG1 pin is a general-purpose I/O pin. Permits core writes. 1 = FLAG1 pin is allocated to interrupt request $\overline{IRQ1}$.
18	IRQ2EN	Flag2 Interrupt Mode. Multiplexed pin. Detailed modes of programming for these bits are provided in “Pin Multiplexing” on page 17-27.
19	TMREXPEN	Flag Timer Expired Mode. Multiplexed pin. Detailed modes of programming for these bits are provided in “Pin Multiplexing” on page 17-27.
20	MSEN	Memory Select Enable. Multiplexed pin. Detailed modes of programming for these bits are provided in “Pin Multiplexing” on page 17-27.
23–21	EPDATA	External Port Data Pin Mode Select.

System and Power Management Registers

Table A-2. SYSCTL Register Bit Descriptions (RW) (Cont'd)

Bit	Name	Description
24	PWM0EN	Pulse Width Modulation Select/Group 0 Select. When cleared (=0) enables FLAG3–0 When set (=1), enables PWM3–0
25	PWM1EN	Pulse Width Modulation Select/Group 1 Select. When cleared (=0) enables FLAG7–4 When set (=1), enables PWM7–4
26	PWM2EN	Pulse Width Modulation Select/Group 2 Select. When cleared (=0) enables FLAG11–8 When set (=1), enables PWM11–8
27	PWM3EN	Pulse Width Modulation Select/Group 30 Select. When cleared (=0) enables FLAG15–12 When set (=1), enables PWM15–12
28	FSYNC	Force Synchronization of the Shared Memory Bus (ADSP-21368 only). 0 = Do not force synchronization 1 = Force synchronization of the shared memory bus
29	BSLK	Bus Lock Request (ADSP-21368 only). Requests bus lock where the processor maintains bus master control if set, (=1) or does not request bus lock (normal bus master control) if cleared (=0).
31–30	Reserved	

Power Management Control Registers (PMCTL)

The power management control register, shown in [Figure A-2](#), is a 32-bit memory-mapped register. This register contains bits to control phase lock loop (PLL) multiplier and divider (both input and output) values, PLL bypass mode, and clock enabling control for peripherals (see [Table A-3 on page A-8](#)). This register also contains status bits, which keep track of the status of the CLK_CFG pins. The reset value of PMCTL is dependent on the CLK_CFG pins (bits 17–16).

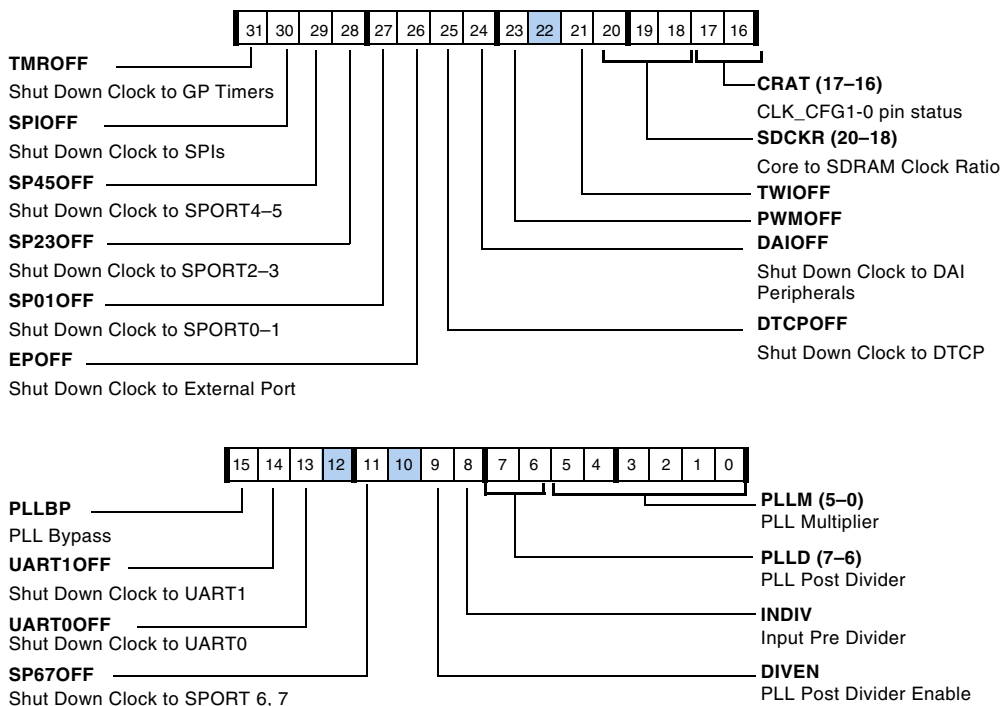

Figure A-2. PMCTL Register

System and Power Management Registers

Table A-3. PMCTL Register Bit Descriptions (RW)

Bit	Name	Description
5–0	PLLM	PLL Input Clock Multiplier. The PLL input clock is multiplied by these settings. For PLLM = 0, PLL multiplier = 64 for 0 < PLLM < 63, PLL multiplier = PLLM Reset value = CLK_CFG[1:0] 00 = 000110 = 6x 01 = 100000 = 32x 10 = 010000 = 16x 11 = 000110 = 6x (Reserved)
7–6	PLLD	PLL Divider (Output Clock Post Divider). 00 = CK divider = 1 01 = CK divider = 2 10 = CK divider = 4 11 = CK divider = 8 A change in the post divider does not require bypass mode.
8	INDIV	PLL Input Clock Pre Divider. 0 = divide by 1 1 = divide by 2
9 (WO)	DIVEN	Output Clock Divider Enable. This bit enables the post divider settings. 0 = Do not load PLLD 1 = Load PLLD When the PLL is programmed using the multipliers and the post dividers, the DIVEN and PLLBP bits should NOT be programmed in the same core clock cycle.
10	Reserved	
11	SP67OFF	Serial Port 6, 7 Clock Disable. 0 = SPORT 6, 7 in normal mode 1 = Shut down clock to SPORT 6, 7
12	CLKOUTEN	Clockout Enable. Mux select for CLKOUT and $\overline{\text{RESETOUT}}$ 0 = Mux output = $\overline{\text{RESETOUT}}$ 1 = Mux output = CLKOUT The CLKOUT functionality is only used for test purposes.

Table A-3. PMCTL Register Bit Descriptions (RW) (Cont'd)

Bit	Name	Description
13	UART0OFF	UART0 Clock Disable. 0 = UART0 is in normal mode 1 = Shut down clock to UART0
14	UART1OFF	UART1 Clock Disable. 0 = UART1 is in normal mode 1 = Shut down clock to UART1
15	PLLBP	PLL Bypass Mode Indication. 0 = PLL is in normal mode 1 = Put PLL in bypass mode
17–16 (RO)	CRAT1–0	PLL Configuration Ratio, CLK_CFG1-0 pins. After reset, both CLK_CFG[1:0] pins defines the CLKIN to core clock ratio. This ratio can be changed with the PLLM and PLLD bits. CRAT = CLK_CFG[1:0] 0 = CLK_CFG[1:0] = 00 (6:1 ratio) 1 = CLK_CFG[1:0] = 01 (32:1 ratio) 2 = CLK_CFG[1:0] = 10 (16:1 ratio) 3 = reserved
20–18	SDCKR2–0	SDRAM Clock Ratio. Core clock to SDRAM clock.000 = SDCKR2 (Ratio = 2.0:1) 001 = SDCKR2_5 (Ratio = 2.5:1) 010 = SDCKR3 (Ratio = 3.0:1) 011 = SDCKR3_5 (Ratio = 3.5:1) 100 = SDCKR4 (Ratio = 4.0:1) 101, 110, 111 = Reserved
21	TWIOFF	TWI Clock Disable. 0 = TWI is in normal mode 1 = Shut down clock to TWI
12	Reserved	
23	PWMOFF	PWM3–0 Clock Disable. 0 = PWM is in normal mode 1 = Shut down clock to PWM
24	DTCPOFF	DTCP/MTM Clock Disable. 0 = DTCP is in normal mode 1 = Shut down clock to DTCP

System and Power Management Registers

Table A-3. PMCTL Register Bit Descriptions (RW) (Cont'd)

Bit	Name	Description
25	DAIOFF	DAI Interface Disable. Shut down clock to DAI related peripherals 0 = DAI is in normal mode 1 = Shutdown clock to DAI If this bit is set the DAI routing unit is also disabled
26	EPOFF	External Port Disable. Shuts down the clock to the asynchronous memory interface as well as SDRAM. 0 = Port is in normal mode 1 = Shut down clock to external port
27	SP01OFF	SPORT0, 1 Disable. 0 = SPORTs 0–1 are in normal mode 1 = Shut down clock to SPORTs 0–1
28	SP23OFF	SPORT2, 3 Disable. 0 = SPORTs 2–3 are in normal mode 1 = Shut down clock to SPORTs 2–3
29	SP45OFF	SPORT4, 5 Disable. 0 = SPORTs 4–5 are in normal mode 1 = Shut down clock to SPORTs 4–5
30	SPIOFF	SPI/SPIB Disable. 0 = SPI is in normal mode 1 = Shut down clock to SPI
31	TMROFF	Timer2–0 Disable. 0 = Timer is in normal mode 1 = Shutdown clock to timer

Running Reset Control Register (RUNRSTCTL)

The `RUNRSTCTL` register is used to control the running reset functionality for ADSP-2137x processors only and is described in [Table A-4](#).

Table A-4. Running Reset Control Register Bit Descriptions (RW)

Bit	Name	Description
0	PM_RUNRST_PINEN	Configures the $\overline{\text{RESETOUT}}$ pin for RUNRST input. 0 = $\overline{\text{RESETOUT}}$ pin is $\overline{\text{RESETOUT}}$ 1 = $\overline{\text{RESETOUT}}$ pin is $\overline{\text{RUNRSTIN}}$ input
1	PM_RUNRST_EN	Enable the Running Reset Functionality. If this bit is cleared, attempting to cause a running reset by toggling the $\overline{\text{RUNRSTIN}}$ pin has no affect. 0 = Running reset disabled 1 = Running reset enabled
31–2	Reserved	

Peripheral Registers

The registers in the following sections are used for the peripherals that are not routed through the signal routing units (SRU, SRU2).

External Port Registers

The following registers are used to control asynchronous memory interface (AMI), the SDRAM controller (SDC), and the shared memory interface (ADSP-21368 only).

Peripheral Registers

Control Register (EPCTL)

The external port control register can be programmed to arbitrate the accesses between the processor core and DMA, and between different DMA channels. These registers are shown in [Figure A-3](#) and described in [Table A-5](#).

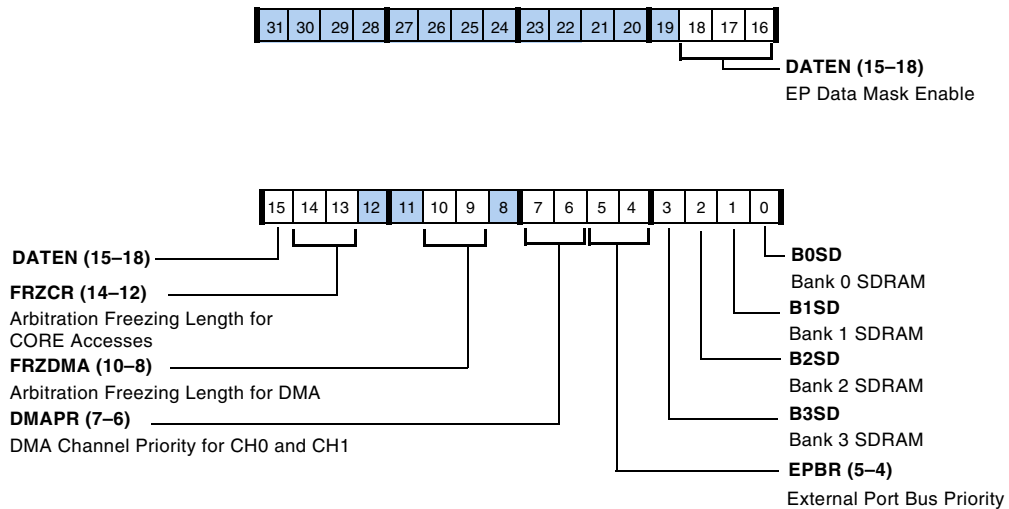

Figure A-3. EPCTL Register

Table A-5. EPCTL Register Bit Descriptions (RW)

Bit	Name	Description
0	B0SD	Select Bank 0 SDRAM. 0 = Bank 0 non-SDRAM 1 = Bank 0 SDRAM
1	B1SD	Select Bank 1 SDRAM. 0 = Bank 1 Non-SDRAM 1 = Bank 1 SDRAM
2	B2SD	Select Bank 2 SDRAM. 0 = Bank 2 Non-SDRAM 1 = Bank 2 SDRAM Note that the $\overline{MS2}$ pin is multiplexed
3	B3SD	Select Bank 3 SDRAM. 0 = Bank 3 Non-SDRAM 1 = Bank 3 SDRAM Note that the $\overline{MS3}$ pin is multiplexed
5–4	EPBR	External Port Bus Priority. 00 = Reserved 01 = DMA has high priority 10 = Core has high priority 11 = Rotating priority (default)
7–6	DMAPR	External Port DMA Channel Priority. 00 = Reserved 01 = Reserved 10 = Fixed priority 11 = Rotating priority (default) Note the fixed priority CH1 over CH0 is not supported.
8	Reserved	
10–9	FRZDMA	Arbitration Freezing Length for DMA. 00 = No Freezing 01 = 4 Accesses 10 = 8 Accesses 11 = 16 Accesses
12–11	Reserved	

Peripheral Registers

Table A-5. EPCTL Register Bit Descriptions (RW) (Cont'd)

Bit	Name	Description
14–13	FRZCR	Arbitration Freezing Length for CORE Accesses. 00 = No Freezing 01 = 4 Accesses 10 = 8 Accesses 11 = 16 Accesses
18–15	DATEN	EP Data Mask Enable. In no pack mode of the SDRAM/AMI memory controller, masks those bits of the data lane (DL) with zeros. The data lane is 8 bits. The 32-bit data bus has four data lanes. DATA31–24 is mapped to DATEN3 DATA23–16 is mapped to DATEN2 DATA15–8 is mapped to DATEN1 DATA7–0 is mapped to DATEN0 For example, if DATEN is 1010, then DL3 and DL1 are masked with zeros.
31–19	Reserved	

ADSP-21367/8/9 External Port DMA Control Registers (DMACx)

The DMAC0-1 registers control the DMA function of their respective DMA channels. These registers are shown in [Figure A-4](#) and described in [Table A-6](#).

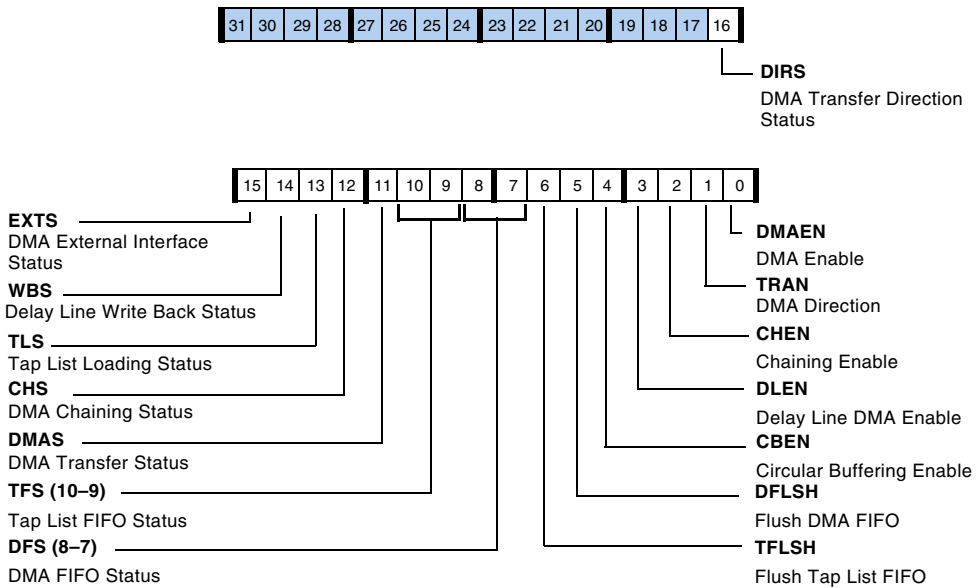

Figure A-4. DMACx Registers (ADSP-21367/8/9)

Peripheral Registers

Table A-6. DMACx Register Bit Descriptions (RW)

Bit	Name	Description
0	DMAEN	DMA Enable. 0 = External port channel x DMA is disabled 1 = Enable External port DMA for channel x
1	TRAN	DMA Direction. Determines the DMA data direction. 0 = Write to internal memory (external reads) 1 = Read from internal memory (external writes) Note: If delay line DMA is enabled then the TRAN bit has no effect. For delay line DMA, transfer direction depends on the state of delay line transfers.
2	CHEN	Enable Chaining. 0 = Chaining disabled 1 = Chaining enabled
3	DLEN	Enable Delay Line DMA. DLEN is applicable only if CHEN = 1. 0 = Delay-line DMA disabled 1 = Delay-line DMA enabled
4	CBEN	Circular Buffering Enable. 0 = Disables circular buffering with delay line DMA 1 = Enables circular buffering with delay line DMA Circular Buffering can be used with normal DMA as well
5 (WOC)	DFLSH	Flush DMA FIFO. Clears the DFS bit.
6 (WOC)	TFLSH	Flush Tap List FIFO. Clears the TFS bit.
8–7 (RO)	DFS	DMA FIFO Status. 00 = FIFO empty 01 = FIFO partially full 11 = FIFO full 10 = Reserved
10–9 (RO)	TFS	Tap List FIFO Status. 00 = FIFO empty 01 = FIFO partially full 11 = FIFO full 10 = Reserved

Table A-6. DMACx Register Bit Descriptions (RW) (Cont'd)

Bit	Name	Description
11 (RO)	DMAS	DMA Transfer Status. 0 = DMA idle 1 = DMA in progress
12 (RO)	CHS	DMA Chaining Status. 0 = DMA chain loading is not active 1 = DMA chain loading is active
13 (RO)	TLS	Tap List Loading Status. 0 = Tap list loading is not active 1 = Tap list loading is active
14 (RO)	WBS	Delay Line Write Pointer Write Back Status. 0 = Write pointer write back is not active 1 = Write pointer write back is active
15 (RO)	EXTS	DMA External Interface Status. 0 = DMA external interface does not have any access pending 1 = DMA external interface has access pending
16 (RO)	DIRS	DMA Transfer Direction Status. 0 = DMA direction is external reads 1 = DMA direction is external writes Note: This is useful for delay line DMA where the transfer direction changes with the state of the DMA state machine. For standard DMA, DIRS reflects the state of the TRAN bit.
31–17	Reserved	

ADSP-2137x External Port DMA Control Registers (DMACx)

The DMAC0–1 registers control the DMA function of their respective DMA channels. These registers are shown in [Figure A-4](#) and described in [Table A-5](#).

Peripheral Registers

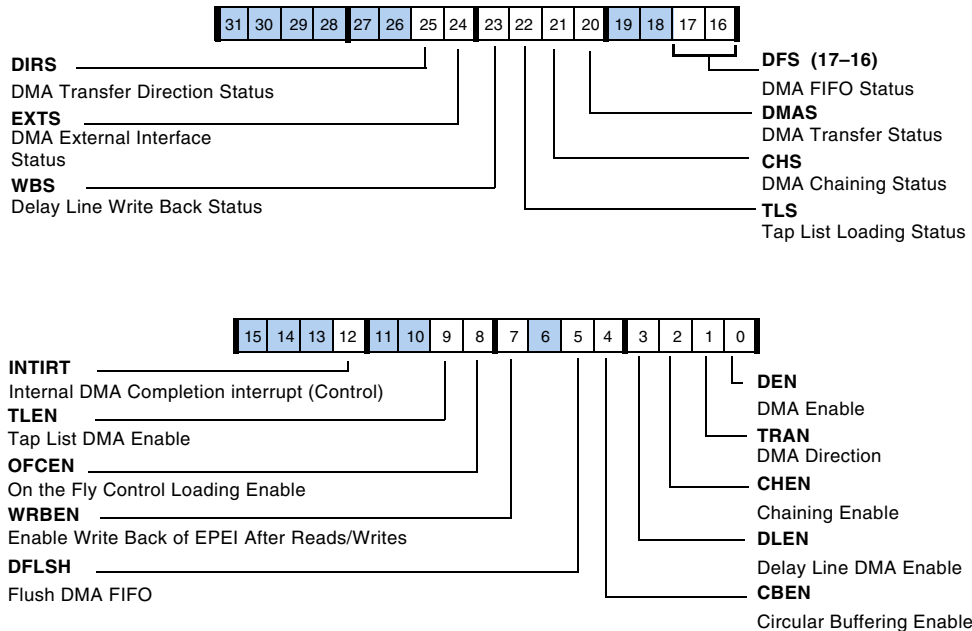

Figure A-5. DMACx Registers (ADSP-21371/75)

Table A-7. DMACx Register Bit Descriptions (RW)

Bit	Name	Description
0	DEN	DMA Enable. 0 = External port channel x DMA is disabled 1 = Enable External port DMA for channel x
1	TRAN	DMA Direction. Determines the DMA data direction. For internal to internal transfers, TRAN must be set. 0 = Write to internal memory (external reads) 1 = Read from internal memory (external writes) Note: If delay line DMA is enabled then the TRAN bit doesn't have any effect. For delay line DMA, transfer direction depends on the state of delay line transfers.
2	CHEN	Enable Chaining. 0 = Chaining disabled 1 = Chaining enabled

Table A-7. DMACx Register Bit Descriptions (RW) (Cont'd)

Bit	Name	Description
3	DLEN	Enable Delay Line DMA. DLEN is applicable only if CHEN=1. 0 = Delay-line DMA disabled 1 = Delay-line DMA enabled
4	CBEN	Circular Buffering Enable. 0 = Disables circular buffering with delay line DMA 1 = Enables circular buffering with delay line DMA Circular buffering can be used with normal DMA as well, if circular buffering is enabled with chaining in normal DMA then ELEP and EBEP should be part of the TCB.
5 (WOC)	DFLSH	Flush DMA FIFO. Clears the DFS bit.
6	Reserved	
7	WRBEN	Enable Write Back of EIEP After Reads/Writes. Write back to EIEP register supported for all DMA modes except for Scatter/Gather DMA. It is automatically enabled for Delay Line DMA. WRBEN is applicable only if CHEN=1
8	OFCEN	On the Fly Control Loading Enable. The control bits in CPEP register are used to describe the next TCB behavior if OFCEN is set and therefore the DMA controls can be changed from TCB to TCB. 0 = Disables the control bits in CPEP register 1 = Enables the control bits in CPEP register. Note if chaining is enabled (OFCEN bit set) then the TRAN bit has no effect, and direction is determined by the CPD bit in the CPEP register.
9	TLEN	Scatter/Gather (Tap List) DMA Enable. 0 = Disables the tap list based scatter/gather DMA 1 = Enables the tap list based scatter/gather DMA
11–10	Reserved	
12	INTIRT	Internal DMA Completion Interrupt (Control). 0 = Interrupt on access completion (internal/external DMA completion depending on external read/write) 1 = Interrupt on internal DMA completion This bit is provided for backward compatibility with older SHARC's.
15–13	Reserved	

Peripheral Registers

Table A-7. DMACx Register Bit Descriptions (RW) (Cont'd)

Bit	Name	Description
17–16 (RO)	DFS	DMA FIFO Status. 00 = FIFO Empty 01 = FIFO Partially Full 11 = FIFO Full 10 = Reserved
19–18	Reserved	
20 (RO)	DMAS	DMA Transfer Status. 0 = DMA idle 1 = DMA in progress
21 (RO)	CHS	DMA Chaining Status. 0 = DMA chain loading is not active 1 = DMA chain loading is active
22 (RO)	TLS	TAP List Loading Status. 1 = TAP list loading is active 0 = TAP list loading is not active
23 (RO)	WBS	Delay Line Write Pointer Write Back Status. 0 = Write pointer write back is not active 1 = Write pointer write back is active
24 (RO)	EXTS	DMA External Interface Status. 0 = DMA external interface does not have any access pending 1 = DMA external interface has access pending
25 (RO)	DIRS	DMA Transfer Direction Status. 0 = DMA direction is external reads 1 = DMA direction is external writes This is useful for delay line DMA where the transfer direction changes with the state of the DMA state machine. For standard DMA, DIRS reflects the state of the TRAN bit.
31–26	Reserved	

AMI Control Registers (AMICTLx)

The AMICTL0-3 registers control the mode of operations for the four banks of external memory. These registers are shown in Figure A-6 and described in Table A-8. Note for all AMI timing bit settings, all defined cycles are derived from the SDRAM clock.

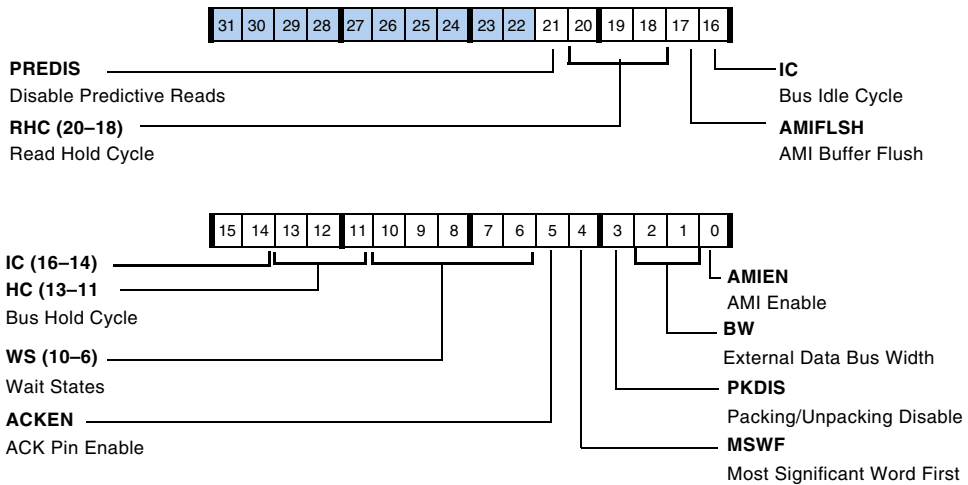

Figure A-6. AMICTLx Registers

Peripheral Registers

Table A-8. AMICTLx Register Bit Descriptions (RW)

Bit	Name	Description
0	AMIEN	<p>AMI Enable. Enables the AMI controller for the dedicated external bank.</p> <p>0 = AMI is disabled 1 = AMI is enabled</p> <p>To access an external memory bank, the AMIEN bit in the corresponding AMICTLx register has to be set. If any of the AMIEN bits are set, then the AMI is enabled and can access memory. However, bank selects can not be driven for that bank whose AMIEN is not set (but read/write strobes can occur).</p> <p>Any access made to a bank whose AMIEN bit is not set occurs at WS = 2 and 8-bit mode without any hold/idle cycles. In any case this access occurs without the bank select and is a void access. Moreover, the AMIEN bit should not be cleared when an access is on-going (when the AMIS bit in the AMISTAT register is set).</p>
2–1	BW	<p>External Data Bus Width.</p> <p>00 – 8-bit 01 – 16-bit 10 – 32-bit 11 – reserved</p>
3	PKDIS	<p>Disable Packing/Unpacking.</p> <p>0 = 8/16-bit data received packed to 32-bit data. Similarly, 32-bit data to be transmitted is unpacked to four 8-bit data.</p> <p>1 = 8/16-bit data received zero-filled, for transmitted data only 8/16-bit LSB part of the 32-bit data is written to external memory. Note that packing is dependent on the BW bits. Also note this bit should not be set for bank 0 which is used for instruction fetch.</p>
4	MSWF	<p>Most Significant Word First. Applicable only with packing disabled (PKDIS=0).</p> <p>0 = 1st 8/16-bit word read/write occupies the least significant position in the 32-bit packed word.</p> <p>1 = 1st 8/16-bit word read/write occupies the most significant position in the 32-bit packed word.</p>
5	ACKEN	<p>Enable the ACK pin. If enabled, reads/writes to devices must be extended by the corresponding devices by pulling ACK low. When ACKEN is set, then the ACK pin is sampled after the wait state value is programmed</p>

Table A-8. AMICTLx Register Bit Descriptions (RW) (Cont'd)

Bit	Name	Description
10–6	WS	<p>Wait States. 00000 = Reserved (wait state value of 32 if used) 00001 = wait state=1 (only if ACK input used) 00010 = wait state = 2 11111 = Wait state = 31</p> <p>Wait states and acknowledge signals are used to allow the processors to connect to memory-mapped peripherals and slower memories. Wait states are programmable from 1 to 31.</p>
13–11	HC	<p>Bus Hold Cycle at the End of Write Access. 000 = Disable bus hold cycle 001 = Hold address for one external port clock cycle 010 = Hold address for two external port clock cycles</p> <p>A bus hold cycle is an inactive bus cycle that the processor automatically generates at the end of a write to allow a longer hold time for address and data. Programs may disable holds, or hold off processing for one or more external port processor cycles. Note the address, data (if a write), and bank select (if in banked external memory) remain unchanged and are driven for one or more cycles after the read or write strobes are deasserted.</p>
16–14	IC	<p>Bus Idle Cycle. Default Idle cycles are inserted whenever read to write in a bank or read to read between two external banks or a read to the SDC happened. 000 = 0 cycles, 001 = 1 cycle 010 = 2 cycles, 011 = 3 cycles 100 = 4 cycles, 101 = 5 cycles 110 = 6 cycles, 111 = 7 cycles</p> <p>A bus idle cycle is an inactive bus cycle that the processor automatically generates to avoid data bus driver conflicts. Such a conflict can occur when a device with a long output disable time continues to drive after \overline{RD} is de-asserted, while another device begins driving on the following cycle. Idle cycles are also required to provide time for a slave in one bank to three-state its ACK driver, before the slave in the next bank enables its ACK driver.</p>
17 (WO)	AMIFLSH	<p>AMI Buffer Flush. Flushes both AMIRX and AMITX buffers. 0 = Buffer holds the data 1 = Flush the buffer</p>

Peripheral Registers

Table A-8. AMICTLx Register Bit Descriptions (RW) (Cont'd)

Bit	Name	Description
20–18	RHC	Read Hold Cycle. Controls the delay between two reads. 000 = Disable read hold cycle 001 = Hold address for one cycle 010 = Hold address for two cycles A Read hold cycle is the delay between two reads at the end of a read access. Programs may disable the read hold cycle, or hold the address for one or more external port clock cycles.
21	PREDIS	Disable Predictive Reads. Default is predictive reads are enabled. Note this bit is global, if set it does apply to all external banks. For more information, see “Predictive Reads” on page 3-15.
31–22	Reserved	

AMI Status Register (AMISTAT)

This 32-bit register provides status information for the AMI interface and can be read at any time. This register is shown in [Figure A-7](#) and described in [Table A-9](#).

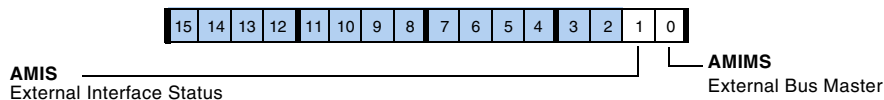

Figure A-7. AMISTAT Register

Table A-9. AMISTAT Register Bit Descriptions (RO)

Bit	Name	Description
0	AMIMS	AMI External Bus Master. 0 = SDRAM Controller controls the external bus 1 = AMI controls the external bus (default)
1	AMIS	External Interface Status. 0 = AMI interface idle 1 = AMI access pending
15–2	Reserved	

SDRAM Registers

This section provides complete descriptions of the SDRAM controller’s memory-mapped registers for SDRAM programming.

Control Register (SDCTL)

The SDRAM memory control register includes all programmable parameters associated with the SDRAM access timing and configuration. This 32-bit register is shown in Figure A-8 and described in Table A-10. For more information, see “Register Overview” on page 3-4.

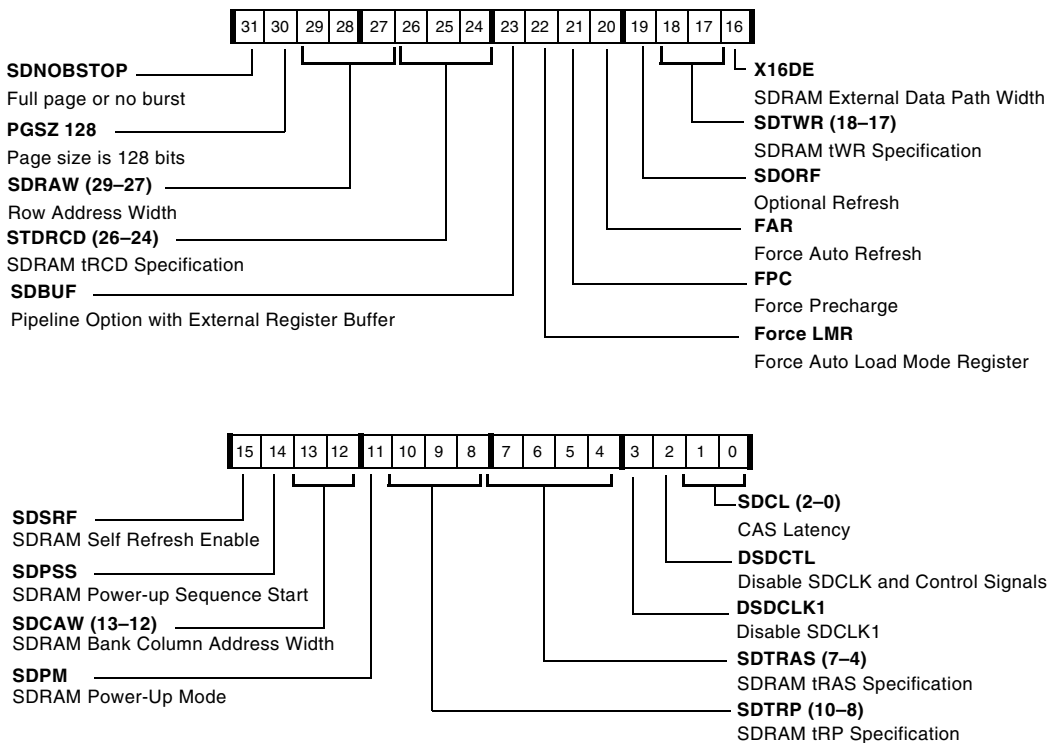

Figure A-8. SDCTL Register (bits 31-16)

Peripheral Registers

Table A-10. SDCTL Register Bit Descriptions (RW)

Bit	Name	Description
1–0	SDCL	SDRAM CAS Latency. 2–3 SDCLK cycles. The delay in clock cycles between when the SDRAM detects the read command and when it provides the data at its output pins. 00, 01 = Reserved 10 = 2 cycles 11 = 3 cycles
2	DSDCTL	Disable Controller and Clocks. Used to enable or disable the SDC. If DSDCTL is disabled, any access to SDRAM address space does not occur externally. When DSDCTL is disabled, all SDC control pins are in their inactive states and the SDRAM clock SDCLK is not running. 1 = Disable 0 = Activate
3	DSDCKL1	Disable SDRAM Clock1. Used to enable or disable SDCLK1. 0 = Activate 1 = Disable Only valid for ADSP-21367/8/9 processors in the BGA package.
7–4	SDTRAS	tRAS Specification. Row Active Open Delay is 1–15 SDCLK cycles. Based on the system clock frequency and the timing specifications of the SDRAM used. Programmed parameters apply to all four banks in the external memory. Refer to the SDRAM data sheet.
10–8	SDTRP	tRP Specification. Row Precharge Delay is 1–8 SDCLK cycles. Based on the system clock frequency and the timing specifications of the SDRAM used. Programmed parameters apply to all four banks in the external memory. Refer to the SDRAM data sheet.
11	SDPM	SDRAM Power-Up Mode. The SDPM and SDPSS bits work together to specify and prepare an SDRAM power-up (initialization) sequence. If the SDPM bit is set (=1), the SDC is prepared to start a precharge all command, followed by a load mode register command, followed by eight auto-refresh cycles. If the SDPM bit is cleared (=0), the SDC does a precharge all command, followed by eight auto-refresh cycles, followed by a load mode register command. Note an access is required to trigger this sequence. Refer to the SDRAM data sheet.

Table A-10. SDCTL Register Bit Descriptions (RW) (Cont'd)

Bit	Name	Description
13–12	SDCAW	SDRAM Bank Column Address Width. SDRAM Page Size. 00 = 8 bits 01 = 9 bits 10 = 10 bits 11 = 11 bits
14 (WO)	SDPSS	SDRAM Power-Up Sequence Start. The power-up sequence is triggered by setting this bit. Note that there is a latency for this first access to SDRAM because the SDRAM power-up sequence takes many cycles to complete. 0 = No effect 1 = Enable power-up on next SDRAM access
15 (WO)	SDSRF	Self Refresh Entry. When the SDSRF bit is set to 1, self-refresh entry command is triggered. Once the SDC completes any active transfers, the SDC executes the sequence of commands to put the SDRAM into self-refresh mode. Any access to the enabled SDRAM bank causes the SDC to trigger a self-refresh exit command.
16	X16DE	SDRAM External Data Path Width. Selects whether the SDRAM interface is 32 or 16 bits wide. If X16DE = 0, DATA31-0 should be connected to the SDRAM. If X16DE = 1, DATA15-0 should be connected to the SDRAM and 16 to 32-bit packing is performed. Note this bit must be set for ADSP-21375 processor.
18–17	SDTWR	tWR Specification. Write To Precharge Delay) is 1–3 SDCLK cycles. Based on the system clock frequency and the timing specifications of the SDRAM used. Programmed parameters apply to all four banks in the external memory. Refer to the SDRAM data sheet.
19	SDORF	Optional Auto Refresh Command. 0 = Auto refresh occurs when refresh counter expires (see “Auto-Refresh” on page 3-25). 1 = Auto refresh not performed
20	FAR	Force Auto Refresh Command. Performs an auto refresh immediately. 0 = No effect 1 = Force auto refresh

Peripheral Registers

Table A-10. SDCTL Register Bit Descriptions (RW) (Cont'd)

Bit	Name	Description
21	FPC	Force Precharge. Performs a precharge all immediately. 0 = No effect 1 = Force precharge
22	FMR	Force Load Mode Register Command (ADSP-2137x only). This command performs a load mode register command immediately. 0 = No effect 1 = Force MR
23	SDBUF	Pipeline Option with External Register Buffer. 0 = No buffer option 1 = External SDRAM CTL/ADDR control buffer enable
26–24	SDTRCD	SDRAM tRCD Specification. RAS to CAS Delay is = 1–7 SDCLK cycles. Based on the system clock frequency and the timing specifications of the SDRAM used. Programmed parameters apply to all four banks in the external memory. See the SDRAM data sheet.
29–27	SDRAW	Row Address Width. 000=8, 001=9 010=10, 011=11 100=12, 101=13 110=14, 111=15
30	PGSZ 128	Page Size of 128 Words (ADSP-2137x only). Allows programs to configure the SDC for a page size of 128 words (7 bits) which supports most available 32 Mb SDRAMs. 0 = No effect, page size decided by SDCAW bits. 1 = Page size 128 words. Column width = 7 bits, override CAW settings.
31	SDNOB-STOP	No Burst Stop Command (ADSP-2137x only). Selects between full page burst (BL=FP) or no burst mode (BL=1). If set (=1), BL=1 is active and the burst stop command is not performed. If cleared (=0) BL=FP is active using the burst stop command for access interruption. This bit should be cleared if the SDRAM does not support BL=1 mode however supports BL=FP.

Control Status Register (SDSTAT)

The SDRAM status register provides information on the state of the SDC. This information can be used to determine when it is safe to alter SDC control parameters or as a debug aid. This register is shown in [Figure A-9](#) and described in [Table A-11](#).

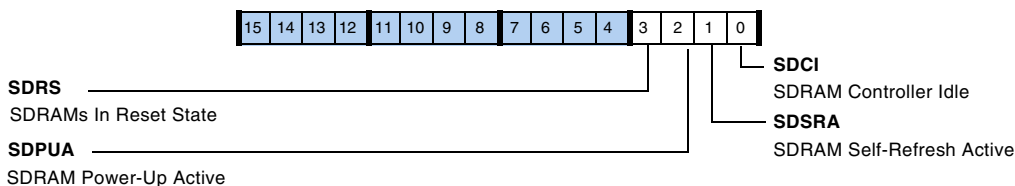

Figure A-9. SDSTAT Register

Table A-11. SDSTAT Register Bit Descriptions (RO)

Bit	Name	Description
0	SDCI	SDC Idle. If set, the SDC is performing a command or auto-refresh. If no access this bit is cleared. 0 = SDC idle 1 = SDC access
1	SDSRA	SDC Self-refresh Mode. If set, the SDC is in self-refresh mode if cleared not. 0 = Non self-refresh mode (SDSRF bit cleared, SDCKE pin high) 1 = Self-refresh mode (SDSRF bit set, SDCKE pin low)
2	SDPUA	SDC Power-up Active. If set, the SDC is in power-up mode if cleared not. 0 = Non power-up mode (SDPSS-bit cleared in SDCTL) 1 = Power-up mode (SDPSS-bit set in SDCTL)
3	SDRS	SDC Reset State. If set, the SDC the power-up sequence happened, if cleared not. 0 = Non power-up sequence 1 = Power-up sequence
15–4	Reserved	

Peripheral Registers

Refresh Rate Control Register (SDRRC)

The SDRAM refresh rate control register provides a flexible mechanism for specifying the auto-refresh timing. The SDC provides a programmable refresh counter which has a period based on the value programmed into the RDIV field of this register, that coordinates the supplied clock rate with the SDRAM device’s required refresh rate. This register is shown in [Figure A-10](#). For more information, see “Register Overview” on page 3-4. and for information on using the SMODIFY bit see “SDRAM Read Optimization” on page 3-41.

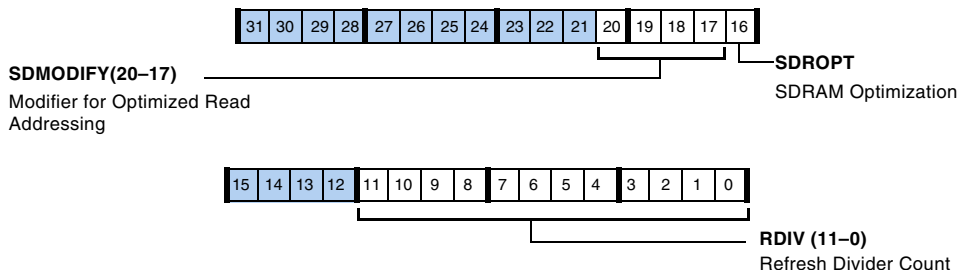

Figure A-10. SDRRC Register

Table A-12. SDRRC Register Bit Descriptions (RW)

Bit	Name	Description
11–0	RDIV	Refresh Divider Count. This 12-bit field defines the number of SDCLK cycles between to successive auto-refresh commands. Note that RDIV=0 setting is illegal.
15–12	Reserved	
16	SDROPT	SDRAM Read Optimization. If set (=1) enables the Read optimization to improve read throughput for core or EP DMA access. 0 = Disabled 1 = Enabled (default)

Table A-12. SDRRC Register Bit Descriptions (RW) (Cont'd)

Bit	Name	Description
20–17	SDMODIFY	Modifier for optimized Read Addressing. According to SDROPT bit this bit should be set to match the positive DAG or DMA modifier. 0000 = 0 0001 = 1 (default) 1111 = 15
31–21	Reserved	

Shared Memory Status Register (SYSTAT, ADSP-21368 Only)

The reset value has all bits initialized to zero, except for the IDC, CRBM, and CRAT fields, which are set from values on the ADSP-21368’s pins. Note that the SYSCTL register also has some specific shared memory I/F control bits.

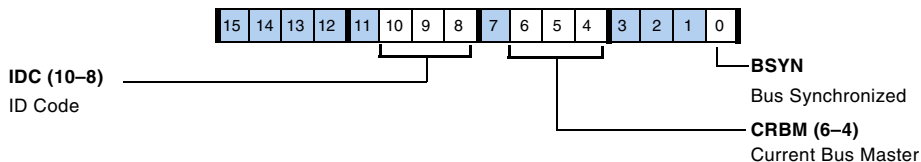

Figure A-11. SYSTAT Register

Table A-13. SYSTAT Register Bit Descriptions (RO)

Bit	Name	Description
0	BSYN	Bus Synchronized. Indicates whether the processor’s bus arbitration logic is synchronized (if set, =1) or is not synchronized (if cleared, =0).
3–1	Reserved	

Peripheral Registers

Table A-13. SYSTAT Register Bit Descriptions (RO) (Cont'd)

Bit	Name	Description
6-4	CRBM	Current Bus Master. These bits indicate the ID of the processor that currently is the bus master in a multiprocessor system. Because CRBM is only valid for DSPs with ID inputs other than zero (for example, a multiprocessor system), the processor keeps CRBM set to 001 when ID equals 000. The reset value of CRBM is undefined.
7	Reserved	
10-8	IDC	ID Code. These bits indicate the state of the ID pins on the processor. The reset value of IDC is undefined.
31-11	Reserved	

Memory-to-Memory Registers

The following DMA related registers are used when performing internal-to-internal DMA through the MTM port.

DMA Control (MTMCTL Register)

The memory-to-memory (MTM) DMA register (MTMCTL) allows programs to transfer blocks of 64-bit data from one internal memory location to another. This transfer method uses two DMA channels, one for reading data and one for writing data. These transfers are controlled using the MTMCTL register shown in [Figure A-12](#).

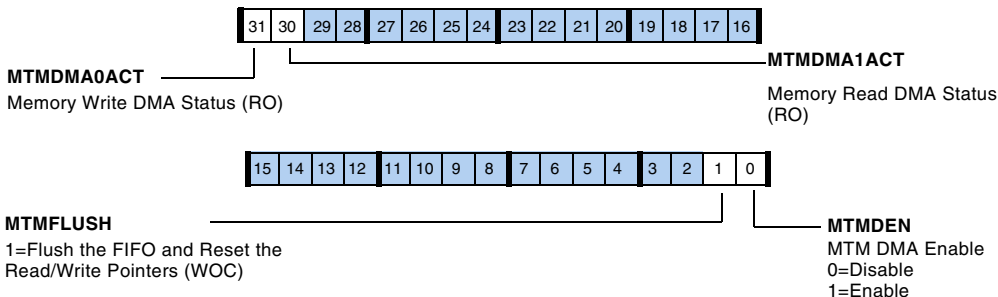

Figure A-12. MTM DMA Register (RW) (MTMCTL)

Pulse Width Modulation Registers

The following registers control the operation of pulse width modulation on the processor.

Global Control Register (PWMGCTL)

This register enables or disables the four PWM groups, in any combination and provides synchronization across the groups. Note that disable bits have higher priority over the enable bits (bit 1 higher as bit 0 and so on). This 16-bit register is shown in [Figure A-13](#).

For the PWM global control register, the traditional read-modify-write operations to disable the PWM group have changed. The action is to directly write—this simplifies the enable/disable of the PWM groups and can be done with fewer instructions. For example, instead of the following code:

```

ustat3 = dm(PWMGCTL);           /* PWM General Control Register */
bit set ustat3 PWM_DIS0;       /* disables group 0 */
dm(PWMGCTL) = ustat3;

```

Use:

```

ustat3 = PWM_DIS0;
dm(PWMGCTL) = ustat3;

```

Peripheral Registers

Writes to the enable and disable bit-pairs for a PWM group works as follows.

$PWM_DISx = 0, PWM_ENx = 0$ – No action

$PWM_DISx = 0, PWM_ENx = 1$ – Enable the PWM group

$PWM_DISx = 1, PWM_ENx = x$ – Disable the PWM group

For reads, the interpretation is as follows.

$PWM_DISx = 0, PWM_ENx = 0$ – PWM group is disabled

$PWM_DISx = 1, PWM_ENx = 1$ – PWM group is enabled

Any other read combination is not possible. Reads of the `PWMGCTL` register returns the enable status on both the enable and disable bits.

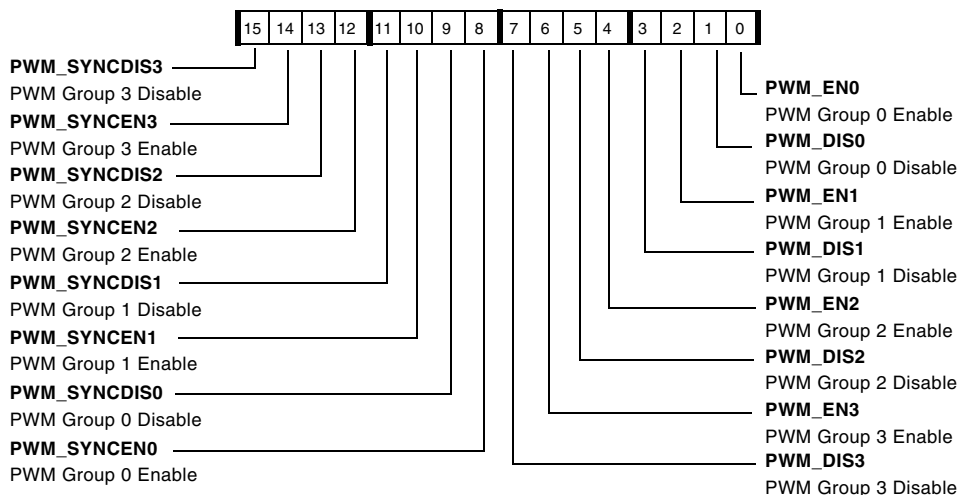

Figure A-13. PWMGCTL Register

Table A-14. PWMGCTL Register Bit Descriptions (RW)

Bit	Name	Function
0, 2, 4, 6	<code>PWM_ENx0</code>	PWM group x enable
1, 3, 5, 7	<code>PWM_DISx</code>	PWM group x disable

Table A-14. PWMGCTL Register Bit Descriptions (RW) (Cont'd)

Bit	Name	Function
8, 10, 12, 14	PWM_SYNCENx	PWM group x enable
9, 11, 13, 15	PWM_SYNCDISx	PWM group x disable

Global Status Register (PWMGSTAT)

This register provides the status of each PWM group (Table A-15). The status bits are set depending on the IRQEN bit. The ISR needs to write one to clear the status bits.

Table A-15. PWMGSTAT Register Bit Descriptions (W1C)

Bit	Name	Function
0	PWM_STAT0	PWM group 0 period completion status
1	PWM_STAT1	PWM group 1 period completion status
2	PWM_STAT2	PWM group 2 period completion status
3	PWM_STAT3	PWM group 3 period completion status
15-4	Reserved	

Control Register (PWMCTLx)

These registers, described in Table A-16, are used to set the operating modes of each PWM block. They also allow programs to disable interrupts from individual groups.

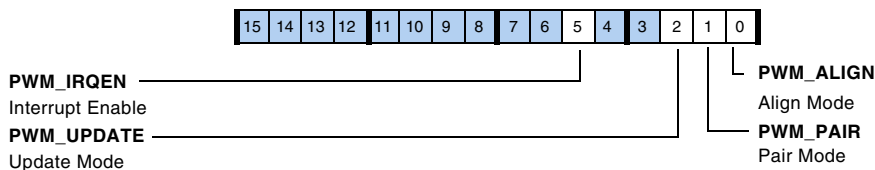

Figure A-14. PWMCTLx Register

Peripheral Registers

Table A-16. PWMCTLx Register Bit Descriptions (RW)

Bit	Name	Description
0	PWM_ALIGN	Align Mode. 0 = Edge-aligned. The PWM waveform is left-justified in the period window. 1 = Center-aligned. The PWM waveform is symmetrical.
1	PWM_PAIR	Pair Mode. 0 = Non-paired mode. The PWM generates independent signals (e.g xH, xL) 1 = Paired mode. The PWM generates the complementary signal from the high side output (xL=/xH).
2	PWM_UPDATE	Update Mode. 0 = Single update mode. The duty cycle values are programmable only once per PWM period. The resulting PWM patterns are symmetrical about the mid-point of the PWM period. 1 = Double update mode. A second update of the PWM registers is implemented at the mid-point of the PWM period. Note PWM_UPDATE mode has only effect for center aligned mode (PWM_ALIGN=1)
4–3	Reserved	
5	PWM_IRQEN	Enable PWM Interrupts. 0 = Interrupts not enabled 1 = Interrupts enabled
15–6	Reserved	

Status Registers (PWMSTATx)

These 16-bit registers, described in [Table A-17](#), report the status of the phase and mode for each PWM group.

Table A-17. PWMSTATx Register Bit Descriptions (RO)

Bit	Name	Description
0	PWM_PHASE	PWM Phase Status. Set during center aligned mode in the second half of each PWM period. Allows programs to determine the particular half-cycle (first or second) during PWM interrupt service routine, if required. 0 = First half 1 = Second half (default) Note in edge aligned mode this bit is always set.
1	Reserved	
2	PWM_PAIRSTAT	PWM Paired Mode Status. 0 = Inactive paired mode 1 = Active paired mode
15–3	Reserved	

Output Disable Registers (PWMSEGx)

These 16-bit registers, described in [Table A-18](#), control the output signals of the four PWM groups. The output signals are enabled by default.

Table A-18. PWMSEGx Register Bit Descriptions (RW)

Bit	Name	Description
0	PWM_BH	Channel B High Disable. Enables or disables the channel B output signal. 0 = Enable 1 = Disable
1	PWM_BL	Channel B Low Disable. Enables or disables the channel B output signal. 0 = Enable 1 = Disable

Peripheral Registers

Table A-18. PWMSEGx Register Bit Descriptions (RW) (Cont'd)

Bit	Name	Description
2	PWM_AH	Channel A High Disable. Enables or disables the channel A output signal. 0 = Enable 1 = Disable
3	PWM_AL	Channel A Low Disable. Enables or disables the channel A output signal. 0 = Enable 1 = Disable
4	BHBL_XOVR	Crossover Enable for BH/BL Pair. 0 = Disable 1 = Enable
5	AHBL_XOVR	Crossover Enable for AH/AL Pair. 0 = Disable 1 = Enable
15–6	Reserved	

Polarity Select Registers (PWMPOLx)

These 16-bit registers, described in [Table A-19](#), control the polarity of the four PWM groups which can be set to either active high or active low. Note that bit 1 has priority over bit 0, bit 3 over bit 2 and so on. In paired mode, it is expected to maintain polarity coherency by setting the same polarity for both the high and low side of a PWM pair.

Table A-19. PWMPOLx Register Bit Descriptions (RW)

Bit	Name	Description
0	PWM_POL1AL	Channel AL Polarity 1. 0 = Channel AL polarity 0 1 = Channel AL polarity 1 (default)
1	PWM_POL0AL	Channel AL Polarity 0. 0 = Channel AL polarity 0 1 = Channel AL polarity 1 (default)

Table A-19. PWMPOLx Register Bit Descriptions (RW) (Cont'd)

Bit	Name	Description
2	PWM_POL1AH	Channel AH Polarity 1. 0 = Channel AH polarity 0 1 = Channel AH polarity 1 (default)
3	PWM_POL0AH	Channel AH Polarity 0. 0 = Channel AH polarity 0 1 = Channel AH polarity 1 (default)
4	PWM_POL1BL	Channel BL Polarity 1. 0 = Channel AL polarity 0 1 = Channel AL polarity 1 (default)
5	PWM_POL0BL	Channel BL Polarity 0. 0 = Channel AL polarity 0 1 = Channel AL polarity 1 (default)
6	PWM_POL1BH	Channel BH Polarity 1. 0 = Channel BH polarity 0 1 = Channel BH polarity 1 (default)
7	PWM_POL0BH	Channel BH Polarity 0. 0 = Channel BH polarity 0 1 = Channel BH polarity 1 (default)
15–8	Reserved	

Period Registers (PWMPERIODx)

These 16-bit RW registers control the unsigned period of the four PWM groups. This register is double buffered for double update mode. A change in one half cycle of PWM switching period only takes effect in the next half period.

Duty Cycle High Side Registers (PWMAx, PWMBx)

The 16-bit duty-cycle control registers (RW) directly control the A/B (two's complement) duty cycles of the two pairs of PWM signals.

DAI Signal Routing Unit Registers

Duty Cycle Low Side Registers (PWMA_Lx, PWMB_Lx)

The 16-bit duty-cycle control registers (RW) directly control the AL/BL duty cycles (two's complement) of the non-paired PWM signals. These can be different from the AH/BH cycles.

Dead Time Registers (PWMD_Tx)

These 16-bit RW registers set up a short time delay (10-bit, unsigned) between turning off one PWM signal and turning on its complementary signal.

Debug Status Registers (PWMD_BGx)

These 16-bit registers aid in software debug activities.

Table A-20. PWMD_BGx Register Bit Descriptions (RO)

Bit	Name	Function
0	PWM_AL	Channel A low output signal for S/W observation
1	PWM_AH	Channel A high output signal for S/W observation
2	PWM_BL	Channel B low output signal for S/W observation
3	PWM_BH	Channel B high output signal for S/W observation
15:4	Reserved	

DAI Signal Routing Unit Registers

The digital applications interface is comprised of a group of peripherals and the signal routing unit (SRU). These register groups are described in the sections that follow.

Clock Routing Control Registers (SRU_CLKx, Group A)

These registers (see [Figure A-15](#) through [Figure A-19](#)) correspond to the group A clock sources listed in [Table A-21](#). Each of the clock inputs are connected to a clock source, based on the 5-bit values in the figures. When either of the precision clock generators is used in external source mode, the SRU_CLK3 register, pins 0–4 and/or pins 5–9, specify the source.

i SPORTs 6 and 7 receive their clocks from other routed sources but cannot route their own clocks to other SPORTs or other peripherals internally through the SRU. If needed externally, route them through the DAI pins.

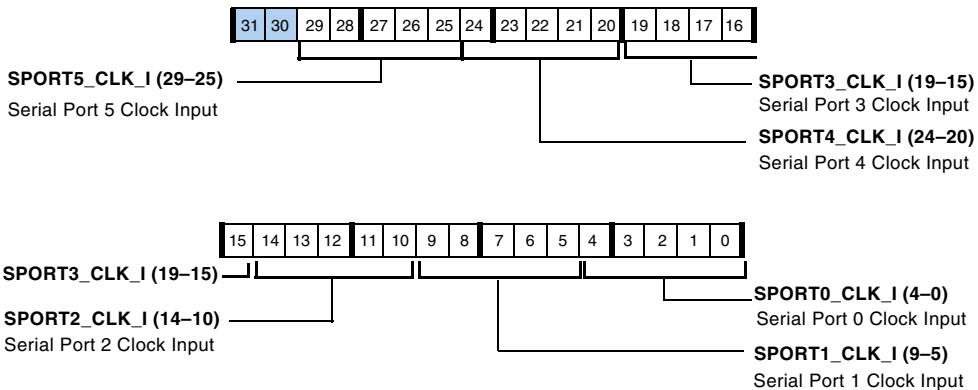

Figure A-15. SRU_CLK0 Register (RW)

DAI Signal Routing Unit Registers

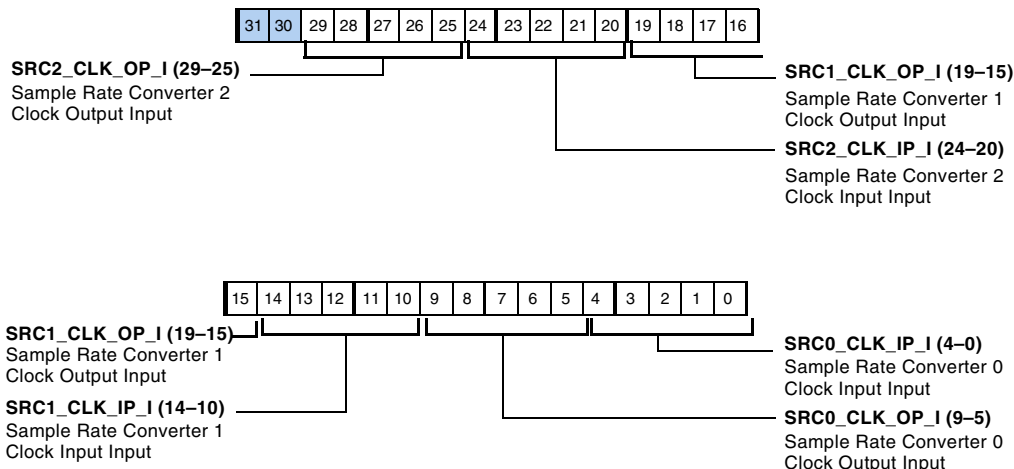

Figure A-16. SRU_CLK1 Register (RW)

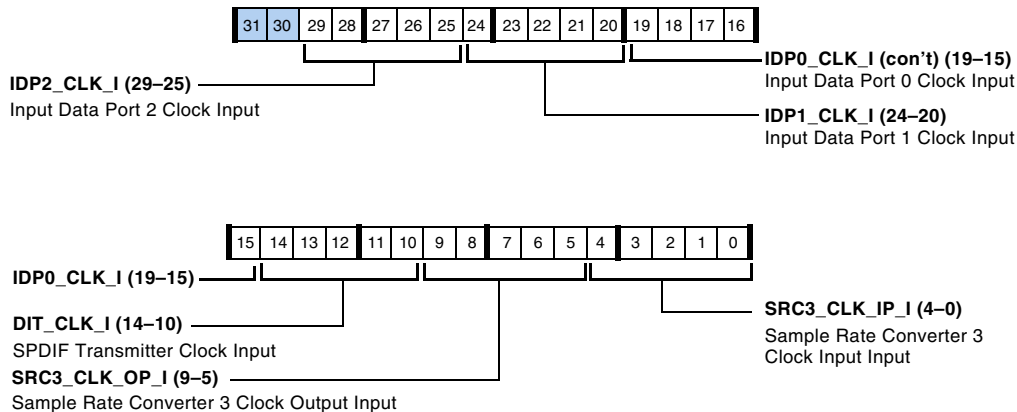

Figure A-17. SRU_CLK2 Register (RW)

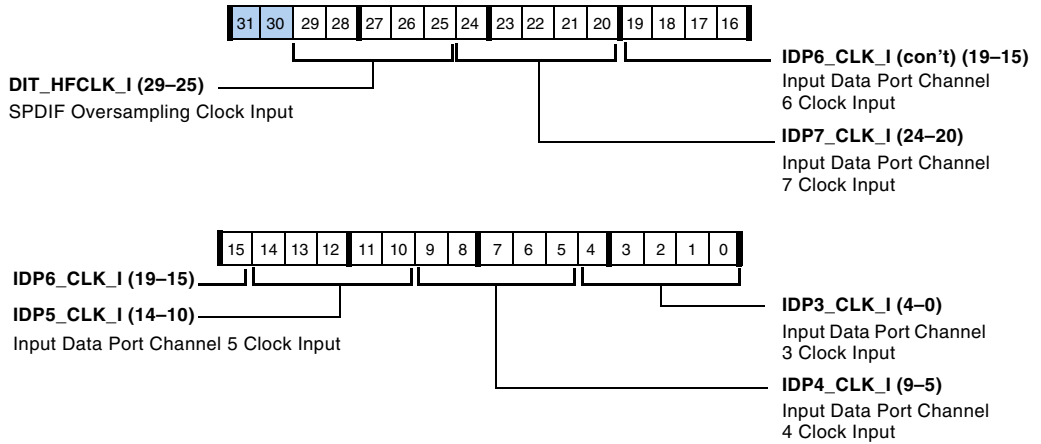

Figure A-18. SRU_CLK3 Register (RW)

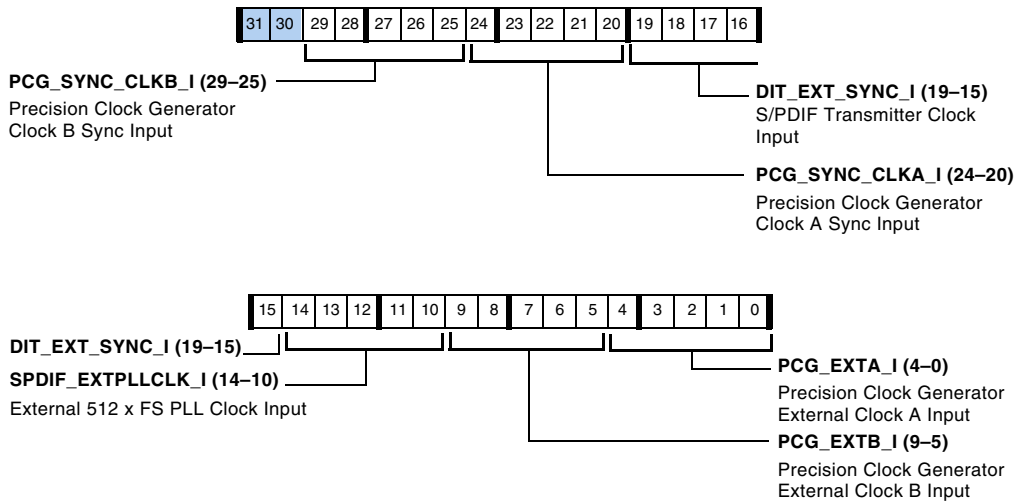

Figure A-19. SRU_CLK4 Register (RW)

DAI Signal Routing Unit Registers

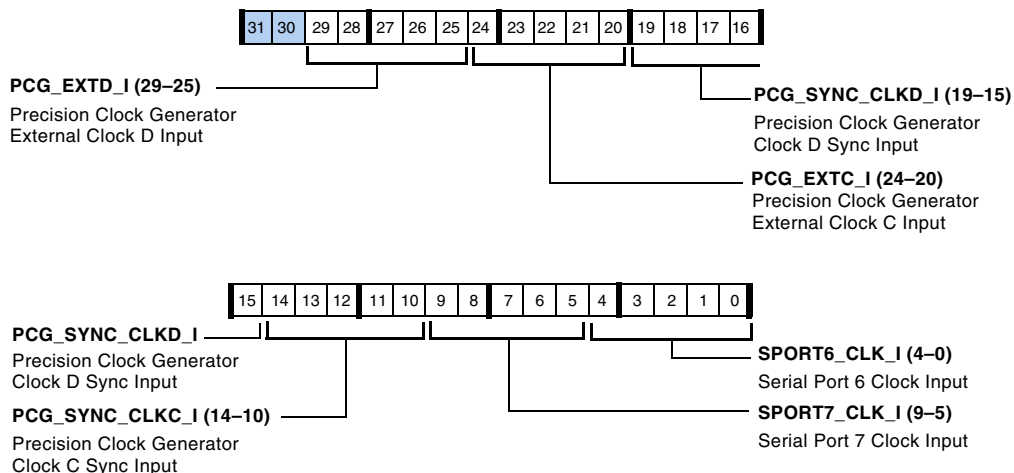

Figure A-20. SRU_CLK5 Register (RW)

Table A-21. Group A Sources – Serial Clock

Selection Code	Source Signal	Description (Source selection)
00000 (0x0)	DAI_PB01_O	Pin buffer 1
00001 (0x1)	DAI_PB02_O	Pin buffer 2
00010 (0x2)	DAI_PB03_O	Pin buffer 3
00011 (0x3)	DAI_PB04_O	Pin buffer 4
00100 (0x4)	DAI_PB05_O	Pin buffer 5
00101 (0x5)	DAI_PB06_O	Pin buffer 6
00110 (0x6)	DAI_PB07_O	Pin buffer 7
00111 (0x7)	DAI_PB08_O	Pin buffer 8
01000 (0x8)	DAI_PB09_O	Pin buffer 9
01001 (0x9)	DAI_PB10_O	Pin buffer 10
01010 (0xA)	DAI_PB11_O	Pin buffer 11
01011 (0xB)	DAI_PB12_O	Pin buffer 12
01100 (0xC)	DAI_PB13_O	Pin buffer 13

Table A-21. Group A Sources – Serial Clock

Selection Code	Source Signal	Description (Source selection)
01101 (0xD)	DAI_PB14_O	Pin buffer 14
01110 (0xE)	DAI_PB15_O	Pin buffer 15
01111 (0xF)	DAI_PB16_O	Pin buffer 16
10000 (0x10)	DAI_PB17_O	Pin buffer 17
10001 (0x11)	DAI_PB18_O	Pin buffer 18
10010 (0x12)	DAI_PB19_O	Pin buffer 19
10011 (0x13)	DAI_PB20_O	Pin buffer 20
10100 (0x14)	SPORT0_CLK_O	SPORT 0 clock
10101 (0x15)	SPORT1_CLK_O	SPORT 1 clock
10110 (0x16)	SPORT2_CLK_O	SPORT 2 clock
10111 (0x17)	SPORT3_CLK_O	SPORT 3 clock
11000 (0x18)	SPORT4_CLK_O	SPORT 4 clock
11001 (0x19)	SPORT5_CLK_O	SPORT 5 clock
11010 (0x1A)	DIR_CLK_O	SPDIF receive clock output
11011 (0x1B)	DIR_TDMCLK_O	SPDIF receive TDM clock output
11100 (0x1C)	PCG_CLKA_O	Precision clock A output
11101 (0x1D)	PCG_CLKB_O	Precision clock B output
11110 (0x1E)	LOW	Logic level low (0)
11111 (0x1F)	HIGH	Logic level high (1)

DAI Signal Routing Unit Registers

Serial Data Routing Registers (SRU_DATx, Group B)

The serial data routing control registers (see [Figure A-22](#) through [Figure A-26](#)) route serial data to the serial ports (A and B data channels) and the input data port. Each of the data inputs specified are connected to a data source based on the 6-bit values shown in [Table A-22](#).

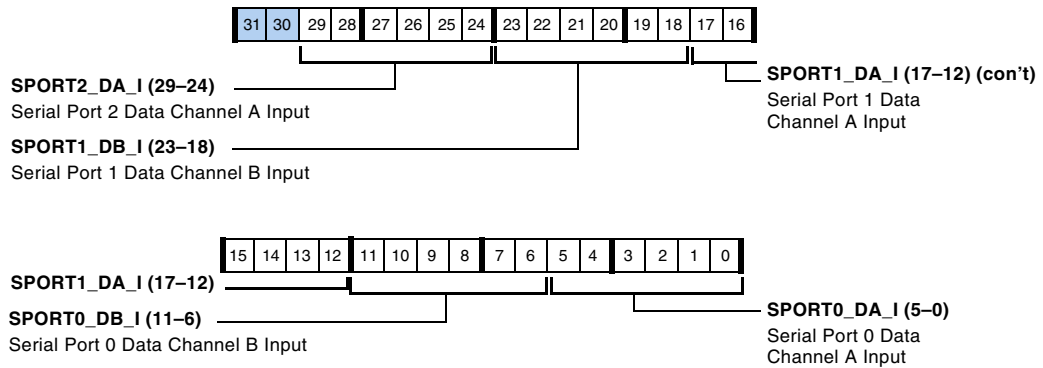

Figure A-21. SRU_DAT0 Register (RW)

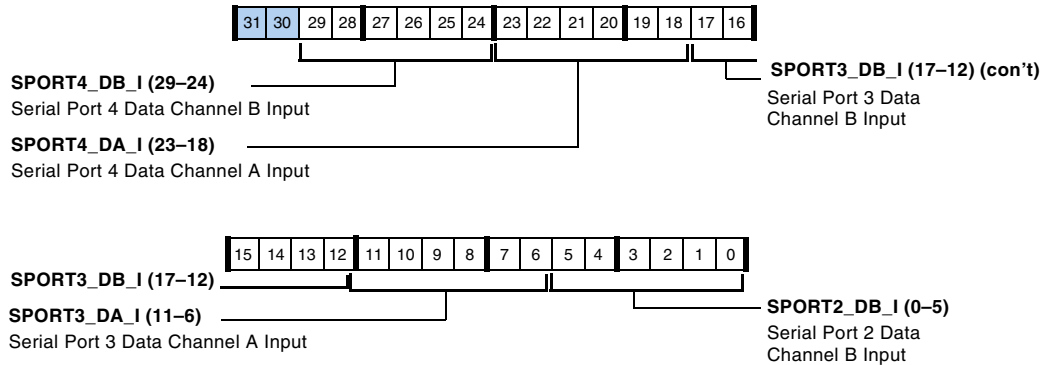

Figure A-22. SRU_DAT1 Register (RW)

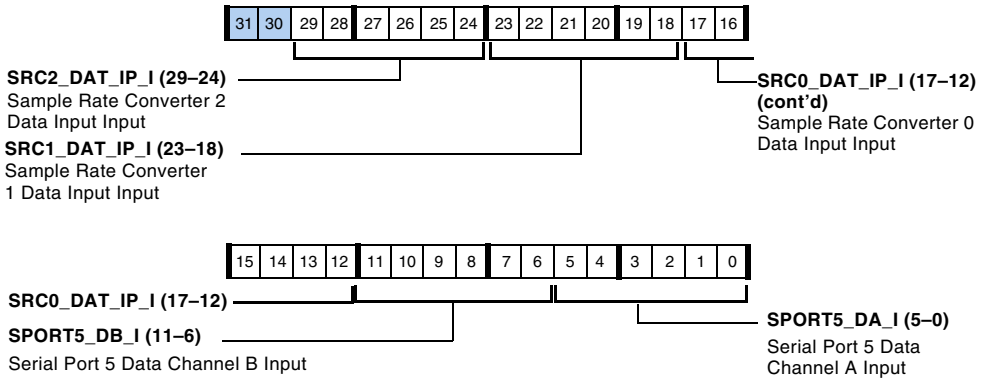

Figure A-23. SRU_DAT2 Register (RW)

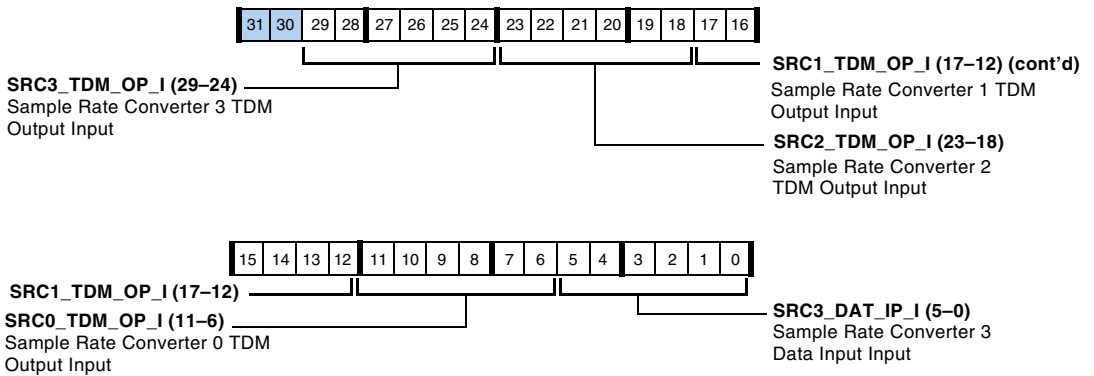

Figure A-24. SRU_DAT3 Register (RW)

DAI Signal Routing Unit Registers

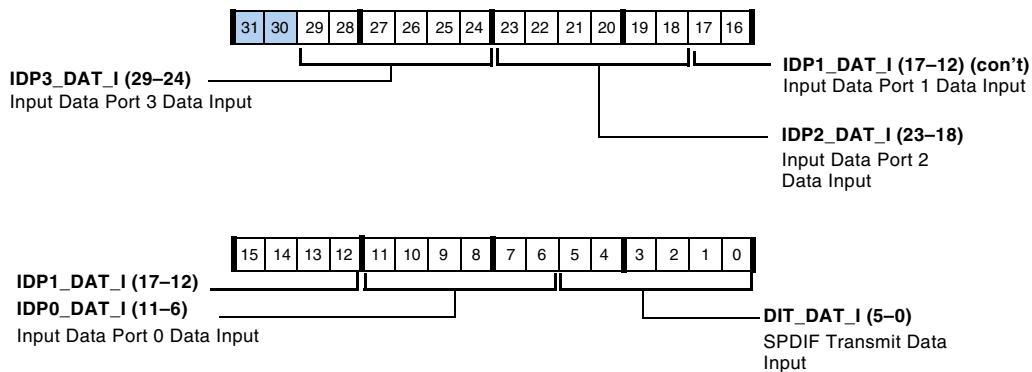

Figure A-25. SRU_DAT4 Register (RW)

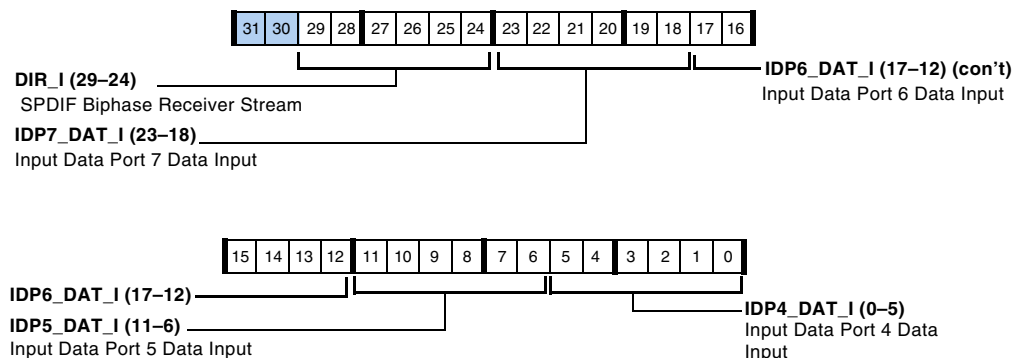

Figure A-26. SRU_DAT5 Register (RW)

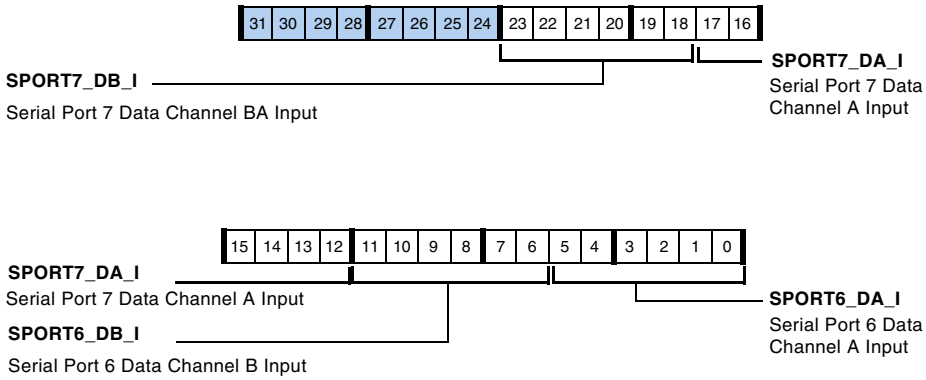

Figure A-27. SRU_DAT6 Register (RW)

Table A-22. Group B Sources – Serial Data

Selection Code	Source Signal	Description (Source selection)
000000 (0x0)	DAI_PB01_O	Pin buffer 1
000001 (0x1)	DAI_PB02_O	Pin buffer 2
000010 (0x2)	DAI_PB03_O	Pin buffer 3
000011 (0x3)	DAI_PB04_O	Pin buffer 4
000100 (0x4)	DAI_PB05_O	Pin buffer 5
000101 (0x5)	DAI_PB06_O	Pin buffer 6
000110 (0x6)	DAI_PB07_O	Pin buffer 7
000111 (0x7)	DAI_PB08_O	Pin buffer 8
001000 (0x8)	DAI_PB09_O	Pin buffer 9
001001 (0x9)	DAI_PB10_O	Pin buffer 10
001010 (0xA)	DAI_PB11_O	Pin buffer 11
001011 (0xB)	DAI_PB12_O	Pin buffer 12
001100 (0xC)	DAI_PB13_O	Pin buffer 13
001101 (0xD)	DAI_PB14_O	Pin buffer 14
001110 (0xE)	DAI_PB15_O	Pin buffer 15

DAI Signal Routing Unit Registers

Table A-22. Group B Sources – Serial Data (Cont'd)

Selection Code	Source Signal	Description (Source selection)
001111 (0xF)	DAI_PB16_O	Pin buffer 16
010000 (0x10)	DAI_PB17_O	Pin buffer 17
010001 (0x11)	DAI_PB18_O	Pin buffer 18
010010 (0x12)	DAI_PB19_O	Pin buffer 19
010011 (0x13)	DAI_PB20_O	Pin buffer 20
010100 (0x14)	SPORT0_DA_O	SPORT 0A data
010101 (0x15)	SPORT0_DB_O	SPORT 0B data
010110 (0x16)	SPORT1_DA_O	SPORT 1A data
010111 (0x17)	SPORT1_DB_O	SPORT 1B data
011000 (0x18)	SPORT2_DA_O	SPORT 2A data
011001 (0x19)	SPORT2_DB_O	SPORT 2B data
011010 (0x1A)	SPORT3_DA_O	SPORT 3A data
011011 (0x1B)	SPORT3_DB_O	SPORT 3B data
011100 (0x1C)	SPORT4_DA_O	SPORT 4A data
011101 (0x1D)	SPORT4_DB_O	SPORT 4B data
011110 (0x1E)	SPORT5_DA_O	SPORT 5A data
011111 (0x1F)	SPORT5_DB_O	SPORT 5B data
100000 (0x20)	SRC0_DAT_OP_O	SRC0 data out
100001 (0x21)	SRC1_DAT_OP_O	SRC1 data out
100010 (0x22)	SRC2_DAT_OP_O	SRC2 data out
100011 (0x23)	SRC3_DAT_OP_O	SRC3 data out
100100 (0x24)	SRC0_TDM_IP_O	SRC0 data out
100101 (0x25)	SRC1_TDM_IP_O	SRC1 data out
100110 (0x26)	SRC2_TDM_IP_O	SRC2 data out
100111 (0x27)	SRC3_TDM_IP_O	SRC3 data out
101000 (0x28)	DIR_DAT_O	SPDIF RX serial data out

Table A-22. Group B Sources – Serial Data (Cont'd)

Selection Code	Source Signal	Description (Source selection)
101100(0x2C)	SPORT6_DA_O	SPORT 6A data
101101(0x2D)	SPORT6_DB_O	SPORT 6B data
101110(0x2E)	SPORT7_DA_O	SPORT 7A data
101111(0x2F)	SPORT7_DB_O	SPORT 7B data
110000(0x30)	DIT_O	SPDIF TX biphasic stream
110001(0x31)–111101(0x3D)	Reserved	
111110 (0x3E)	LOW	Logic level low (0)
111111 (0x3F)	HIGH	Logic level high (1)

Frame Sync Routing Control Registers (SRU_FSx, Group C)

The frame sync routing control registers (see [Figure A-28](#) through [Figure A-31](#)) route a frame sync or a word clock to the serial ports, the SRC, the S/PDIF, and the IDP. Each frame sync input is connected to a frame sync source based on the 5-bit values described in the group C frame sync sources, (listed in [Table A-23](#)).

-  SPORTs 6 and 7 receive their frame syncs from other routed sources but cannot route their own frame syncs to other SPORTs or other peripherals internally through SRU. If needed externally, route them through the DAI pins.

DAI Signal Routing Unit Registers

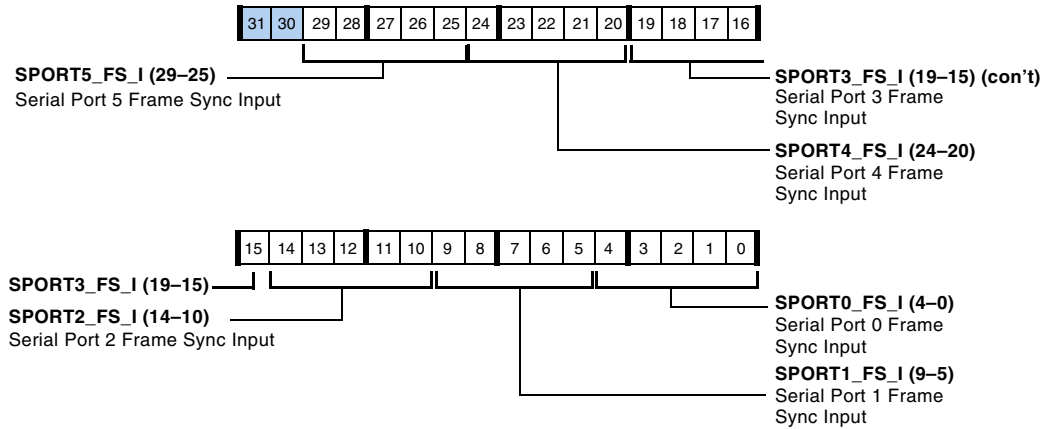

Figure A-28. SRU_FS0 Register (RW)

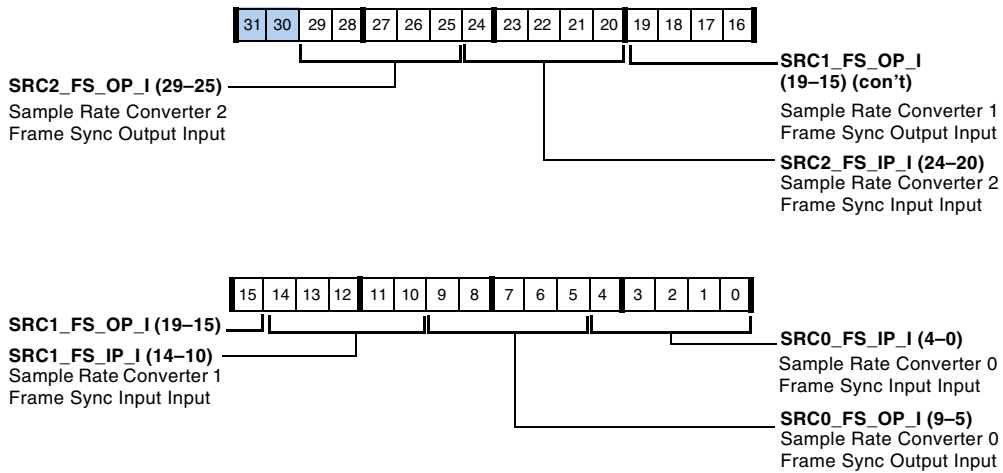

Figure A-29. SRU_FS1 Register (RW)

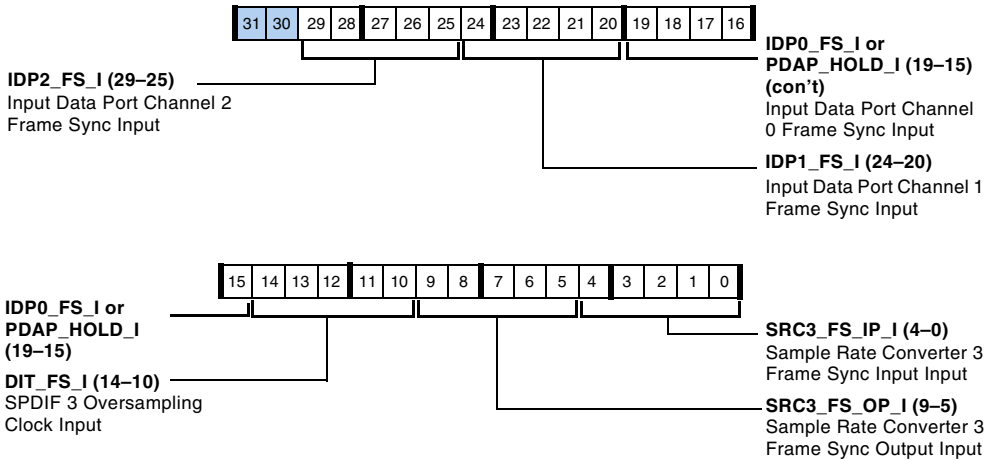

Figure A-30. SRU_FS2 Register (RW)

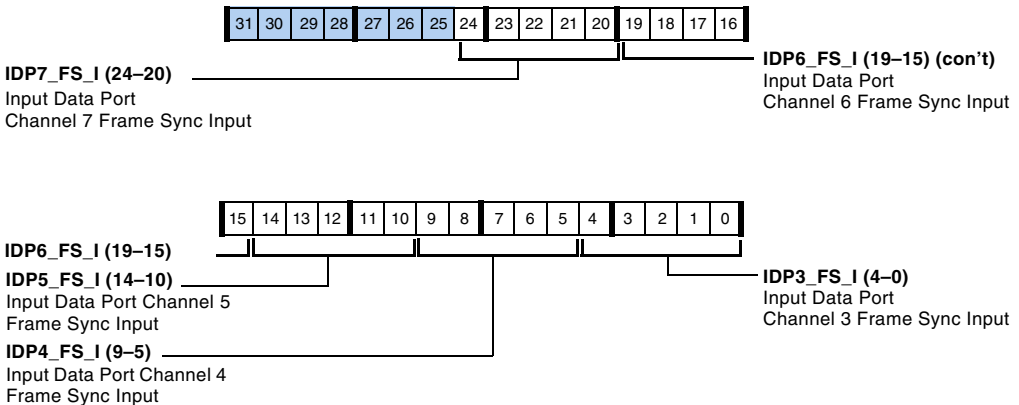

Figure A-31. SRU_FS3 Register (RW)

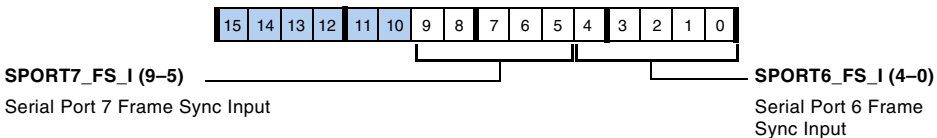

Figure A-32. SRU_FS4 Register (RW)

DAI Signal Routing Unit Registers

Table A-23. Group C Sources – Frame Sync

Selection Code	Source Signal	Description (Source selection)
00000 (0x0)	DAI_PB01_O	Pin buffer 1
00001 (0x1)	DAI_PB02_O	Pin buffer 2
00010 (0x2)	DAI_PB03_O	Pin buffer 3
00011 (0x3)	DAI_PB04_O	Pin buffer 4
00100 (0x4)	DAI_PB05_O	Pin buffer 5
00101 (0x5)	DAI_PB06_O	Pin buffer 6
00110 (0x6)	DAI_PB07_O	Pin buffer 7
00111 (0x7)	DAI_PB08_O	Pin buffer 8
01000 (0x8)	DAI_PB09_O	Pin buffer 9
01001 (0x9)	DAI_PB10_O	Pin buffer 10
01010 (0xA)	DAI_PB11_O	Pin buffer 11
01011 (0xB)	DAI_PB12_O	Pin buffer 12
01100 (0xC)	DAI_PB13_O	Pin buffer 13
01101 (0xD)	DAI_PB14_O	Pin buffer 14
01110 (0xE)	DAI_PB15_O	Pin buffer 15
01111 (0xF)	DAI_PB16_O	Pin buffer 16
10000 (0x10)	DAI_PB17_O	Pin buffer 17
10001 (0x11)	DAI_PB18_O	Pin buffer 18
10010 (0x12)	DAI_PB19_O	Pin buffer 19
10011 (0x13)	DAI_PB20_O	Pin buffer 20
10100 (0x14)	SPORT0_FS_O	SPORT 0 frame sync
10101 (0x15)	SPORT1_FS_O	SPORT 1 frame sync
10110 (0x16)	SPORT2_FS_O	SPORT 2 frame sync
10111 (0x17)	SPORT3_FS_O	SPORT 3 frame sync
11000 (0x18)	SPORT4_FS_O	SPORT 4 frame sync
11001 (0x19)	SPORT5_FS_O	SPORT 5 frame sync

Table A-23. Group C Sources – Frame Sync (Cont'd)

Selection Code	Source Signal	Description (Source selection)
11010 (0x1A)	DIR_FS_O	SPDIF RX frame sync output
11011 (0x1B)	Reserved	
11100 (0x1C)	PCG_FSA_O	Precision frame sync A output
11101 (0x1D)	PCG_FSB_O	Precision frame sync B output
11110 (0x1E)	LOW	Logic level low (0)
11111 (0x1F)	HIGH	Logic level high (1)

Pin Signal Assignment Registers (SRU_PINx, Group D)

Each physical pin (connected to a bonded pad) may be routed using the pin signal assignment registers (see [Figure A-33](#) through [Figure A-37](#)) in the SRU to any of the inputs or outputs of the DAI peripherals, based on the 7-bit values listed in [Table A-24](#). The SRU also may be used to route signals that control the pins in other ways.

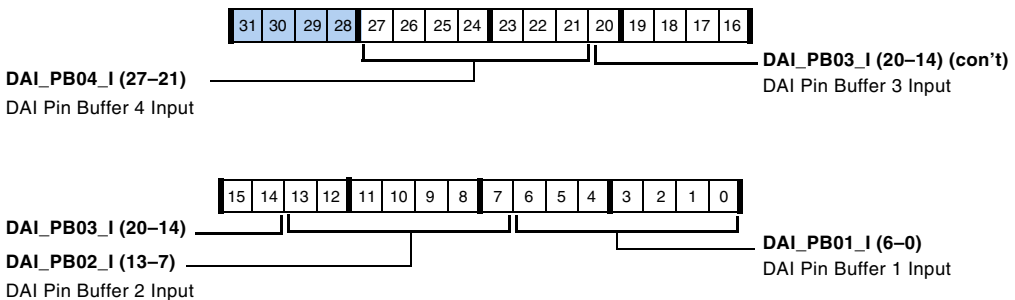

Figure A-33. SRU_PIN0 Register (RW)

DAI Signal Routing Unit Registers

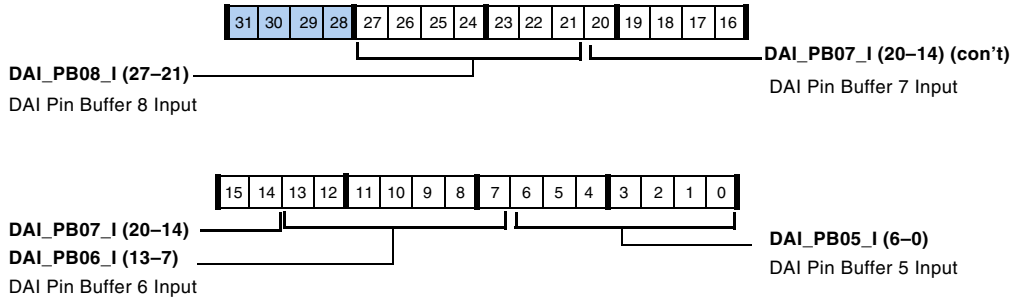

Figure A-34. SRU_PIN1 Register (RW)

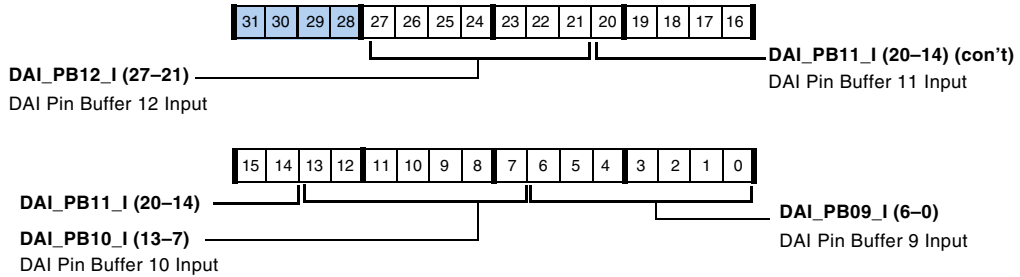

Figure A-35. SRU_PIN2 Register (RW)

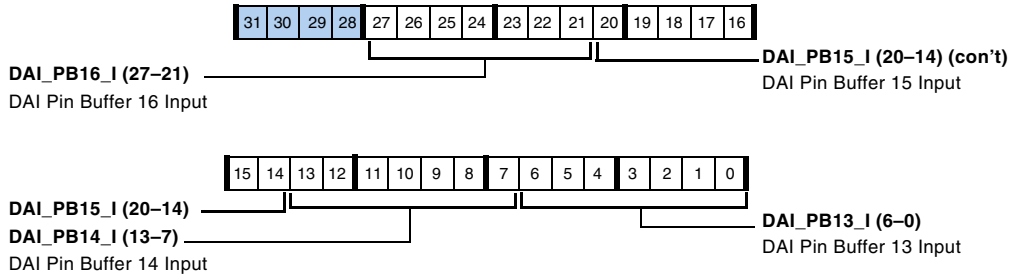

Figure A-36. SRU_PIN3 Register (RW)

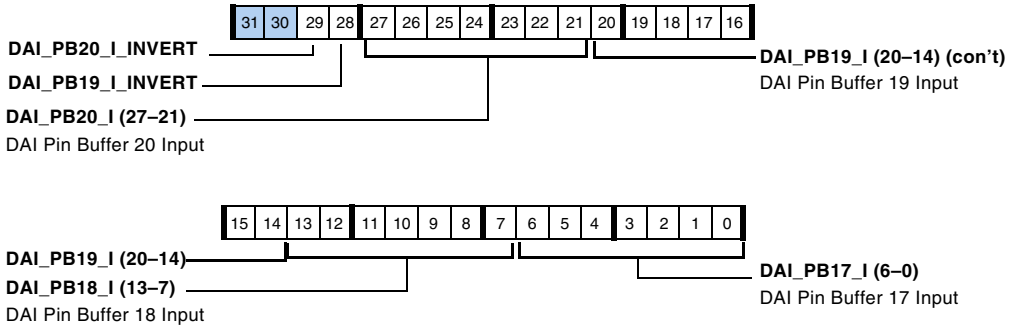

Figure A-37. SRU_PIN4 Register (RW)

Setting SRU_PIN4 bit 28 to high inverts the level of DAI_PB19_I and setting SRU_PIN4 bit 29 to high inverts the level of DAI_PB20_I. Input Inversion only works if the buffer output is not routed to its input.

Table A-24. Group D Sources—Pin Signal Assignments

Selection Code	Source Signal	Description (Source selection)
0000000 (0x0)	DAI_PB01_O	Pin buffer 1
0000001 (0x1)	DAI_PB02_O	Pin buffer 2
0000010 (0x2)	DAI_PB03_O	Pin buffer 3
0000011 (0x3)	DAI_PB04_O	Pin buffer 4
0000100 (0x4)	DAI_PB05_O	Pin buffer 5
0000101 (0x5)	DAI_PB06_O	Pin buffer 6
0000110 (0x6)	DAI_PB07_O	Pin buffer 7
0000111 (0x7)	DAI_PB08_O	Pin buffer 8
0001000 (0x8)	DAI_PB09_O	Pin buffer 9
0001001 (0x9)	DAI_PB10_O	Pin buffer 10
0001010 (0xA)	DAI_PB11_O	Pin buffer 11
0001011 (0xB)	DAI_PB12_O	Pin buffer 12
0001100 (0xC)	DAI_PB13_O	Pin buffer 13

DAI Signal Routing Unit Registers

Table A-24. Group D Sources—Pin Signal Assignments (Cont'd)

Selection Code	Source Signal	Description (Source selection)
0001101 (0xD)	DAI_PB14_O	Pin buffer 14
0001110 (0xE)	DAI_PB15_O	Pin buffer 15
0001111 (0xF)	DAI_PB16_O	Pin buffer 16
0010000 (0x10)	DAI_PB17_O	Pin buffer 17
0010001 (0x11)	DAI_PB18_O	Pin buffer 18
0010010 (0x12)	DAI_PB19_O	Pin buffer 19
0010011 (0x13)	DAI_PB20_O	Pin buffer 20
0010100 (0x14)	SPORT0_DA_O	SPORT 0A data
0010101 (0x15)	SPORT0_DB_O	SPORT 0B data
0010110 (0x16)	SPORT1_DA_O	SPORT 1A data
0010111 (0x17)	SPORT1_DB_O	SPORT 1B data
0011000 (0x18)	SPORT2_DA_O	SPORT 2A data
0011001 (0x19)	SPORT2_DB_O	SPORT 2B data
0011010 (0x1A)	SPORT3_DA_O	SPORT 3A data
0011011 (0x1B)	SPORT3_DB_O	SPORT 3B data
0011100 (0x1C)	SPORT4_DA_O	SPORT 4A data
0011101 (0x1D)	SPORT4_DB_O	SPORT 4B data
0011110 (0x1E)	SPORT5_DA_O	SPORT 5A data
0011111 (0x1F)	SPORT5_DB_O	SPORT 5B data
0100000 (0x20)	SPORT0_CLK_O	SPORT 0 clock
0100001 (0x21)	SPORT1_CLK_O	SPORT 1 clock
0100010 (0x22)	SPORT2_CLK_O	SPORT 2 clock
0100011 (0x23)	SPORT3_CLK_O	SPORT 3 clock
0100100 (0x24)	SPORT4_CLK_O	SPORT 4 clock
0100101 (0x25)	SPORT5_CLK_O	SPORT 5 clock
0100110 (0x26)	SPORT0_FS_O	SPORT 0 frame sync

Table A-24. Group D Sources—Pin Signal Assignments (Cont'd)

Selection Code	Source Signal	Description (Source selection)
0100111 (0x27)	SPORT1_FS_O	SPORT 1 frame sync
0101000 (0x28)	SPORT2_FS_O	SPORT 2 frame sync
0101001 (0x29)	SPORT3_FS_O	SPORT 3 frame sync
0101010 (0x2A)	SPORT4_FS_O	SPORT 4 frame sync
0101011 (0x2B)	SPORT5_FS_O	SPORT 5 frame sync
0101100 (0x2C)	SPORT6_DA_O	SPORT 6A data
0101101 (0x2D)	SPORT6_DB_O	SPORT 6B data
0101110 (0x2E)	SPORT7_DA_O	SPORT 7A data
0101111 (0x2F)	SPORT7_DB_O	SPORT 7B data
0110000 (0x30)	PDAP_STRB_O	PDAP data transfer request strobe
0110001 (0x31)	DIT_BLKSTART_O	S/PDIF TX block start output
0110100 (0x34)	SPORT6_CLK_O	SPORT 6 clock
0110101 (0x35)	SPORT7_CLK_O	SPORT 7 clock
0110110 (0x36)	SPORT6_FS_O	SPORT 6 frame sync
0110111 (0x37)	SPORT7_FS_O	SPORT 7 frame sync
0111000 (0x38)	PCG_CLKA_O	Precision clock A
0111001 (0x39)	PCG_CLKB_O	Precision clock B
0111010 (0x3A)	PCG_FSA_O	Precision frame sync A
0111011 (0x3B)	PCG_FSB_O	Precision frame sync B
0111100 (0x3C)	Reserved	
0111101 (0x3D)	SRC0_DAT_OP_O	SRC0 data output
0111110 (0x3E)	SRC1_DAT_OP_O	SRC1 data output
0111111 (0x3F)	SRC2_DAT_OP_O	SRC2 data output
1000000 (0x40)	SRC3_DAT_OP_O	SRC3 data output
1000001 (0x41)	DIR_DAT_O	SPDIF_RX data output
1000010 (0x42)	DIR_FS_O	SPDIF_RX frame sync output

DAI Signal Routing Unit Registers

Table A-24. Group D Sources—Pin Signal Assignments (Cont'd)

Selection Code	Source Signal	Description (Source selection)
1000011 (0x43)	DIR_CLK_O	SPDIF_RX clock output
1000100 (0x44)	DIR_TDMCLK_O	SPDIF_RX TDM clock output
1000101 (0x45)	DIT_O	SPDIF TX biphas encoded data output
1000110 (0x46)	SPORT0_TDV_O	SPORT0 transmit data valid output
1000111 (0x47)	SPORT1_TDV_O	SPORT1 transmit data valid output
1001000 (0x48)	SPORT2_TDV_O	SPORT2 transmit data valid output
1001001 (0x49)	SPORT3_TDV_O	SPORT3 transmit data valid output
1001010 (0x4A)	SPORT4_TDV_O	SPORT4 transmit data valid output
1001011 (0x4B)	SPORT5_TDV_O	SPORT5 transmit data valid output
1001100 (0x4C)	SPORT6_TDV_O	SPORT6 transmit data valid output
1001101 (0x4D)	SPORT7_TDV_O	SPORT7 transmit data valid output
1001110 (0x4E)	DIR_LRCLK_REF_O	External PLL – reference point connection
1001111 (0x4F)	DIR_LRCLK_FB_O	External PLL – feedback point connection
1010000 (0x50)	PCG_CLKC_O	Precision clock C
1011001 (0x51)	PCG_CLKD_O	Precision clock D
1011010 (0x52)	PCG_FSC_O	Precision frame sync C
1010011 (0x53)	PCG_FSD_O	Precision frame sync D
1010100 – 1111101	Reserved	
1111110 (0x7E)	LOW	Logic level low (0)
1111111 (0x7F)	HIGH	Logic level high (1)

Miscellaneous Signal Routing Registers (SRU_MISCx, Group E)

Miscellaneous register A allows programs to route to the DAI interrupt latch, PBEN input routing, or input signal inversion. In contrast, miscellaneous register B allows programs to only route to the DAI interrupt latch (see [Figure A-38](#) and [Figure A-39](#)).

Notice that when the PCG's one shot option (PCG_PW register) is enabled, the inputs MISCA2_I (PCG unit A) and MISCA3_I (PCG unit B) and MISCA4_I (PCG unit C) and MISCA5_I (PCG unit D) are used as input signals.

The miscellaneous signal routing registers correspond to the group E miscellaneous signals, listed in [Table A-25](#).

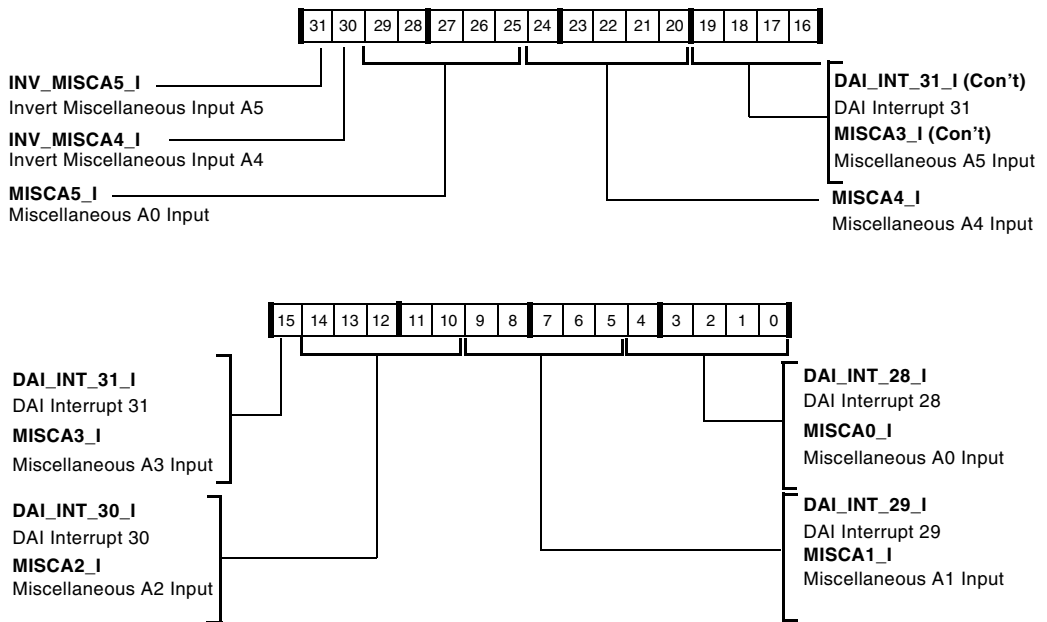

Figure A-38. SRU_EXT_MISCA Register (RW)

DAI Signal Routing Unit Registers

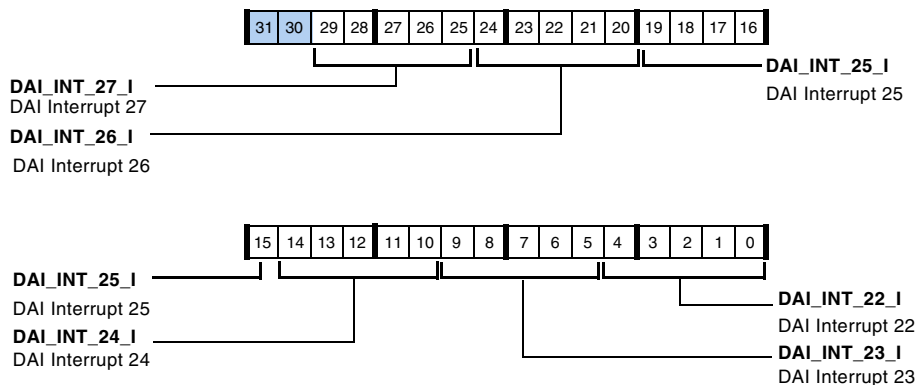

Figure A-39. SRU_EXT_MISCB Register (RW)

Table A-25. Group E Sources—Miscellaneous Signals

Selection Code	Source Signal	Description (Output source selection)
00000 (0x0)	DAI_PB01_O	Pin buffer 1 output
00001 (0x1)	DAI_PB02_O	Pin buffer 2 output
00010 (0x2)	DAI_PB03_O	Pin buffer 3 output
00011 (0x3)	DAI_PB04_O	Pin buffer 4 output
00100 (0x4)	DAI_PB05_O	Pin buffer 5 output
00101 (0x5)	DAI_PB06_O	Pin buffer 6 output
00110 (0x6)	DAI_PB07_O	Pin buffer 7 output
00111 (0x7)	DAI_PB08_O	Pin buffer 8 output
01000 (0x8)	DAI_PB09_O	Pin buffer 9 output
01001 (0x9)	DAI_PB10_O	Pin buffer 10 output
01010 (0xA)	DAI_PB11_O	Pin buffer 11 output
01011 (0xB)	DAI_PB12_O	Pin buffer 12 output
01100 (0xC)	DAI_PB13_O	Pin buffer 13 output
01101 (0xD)	DAI_PB14_O	Pin buffer 14 output
01110 (0xE)	DAI_PB15_O	Pin buffer 15 output

Table A-25. Group E Sources—Miscellaneous Signals (Cont'd)

Selection Code	Source Signal	Description (Output source selection)
01111 (0xF)	DAI_PB16_O	Pin buffer 16 output
10000 (0x10)	DAI_PB17_O	Pin buffer 17 output
10001 (0x11)	DAI_PB18_O	Pin buffer 18 output
10010 (0x12)	DAI_PB19_O	Pin buffer 19 output
10011 (0x13)	DAI_PB20_O	Pin buffer 20 output
10100 (0x14)	SPORT0_FS_O	SPORT0 frame sync
10101 (0x15)	SPORT1_FS_O	SPORT1 frame sync
10110 (0x16)	SPORT2_FS_O	SPORT2 frame sync
10111 (0x17)	SPORT3_FS_O	SPORT3 frame sync
11000 (0x18)	SPORT4_FS_O	SPORT4 frame sync
11001 (0x19)	SPORT5_FS_O	SPORT5 frame sync
11010 (0x1A)	DIT_BLKSTART_O	S/PDIF TX block start output
11011 (0x1B)	PCG_FSA_O	Precision frame sync A
11100 (0x1C)	PCG_CLKB_O	Precision clock B
11101 (0x1D)	PCG_FSB_O	Precision frame sync B
11110 (0x1E)	LOW	Logic level low (0) as a source
11111 (0x1F)	HIGH	Logic level high (1) as a source

DAI Signal Routing Unit Registers

Pin Buffer Enable Registers (SRU_PBENx, Group F)

The pin enable control registers (see [Figure A-40](#) through [Figure A-43](#), [Table A-26](#)) activate the drive buffer for each of the 20 DAI pins. When the pins are not enabled (driven), they can be used as inputs.

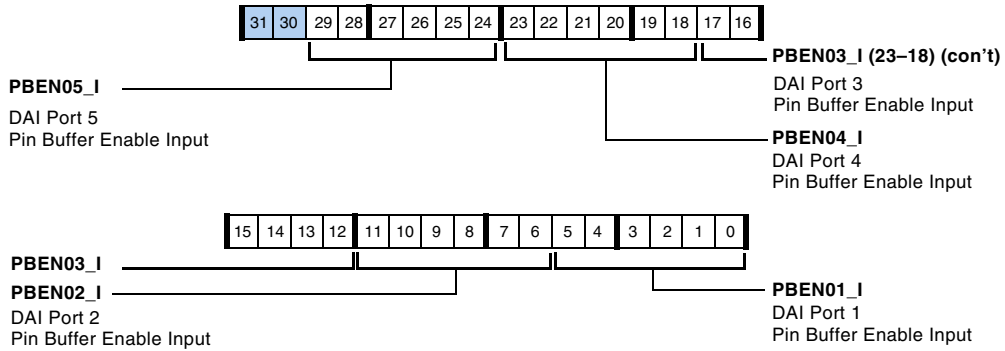

Figure A-40. SRU_PBEN0 (RW)

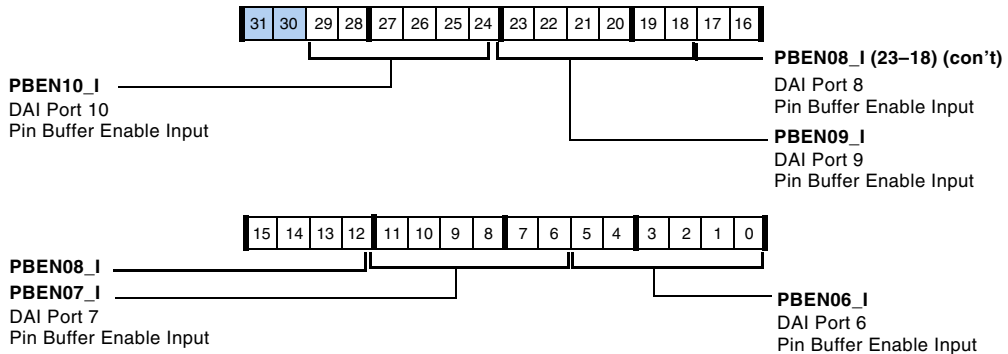

Figure A-41. SRU_PBEN1 (RW)

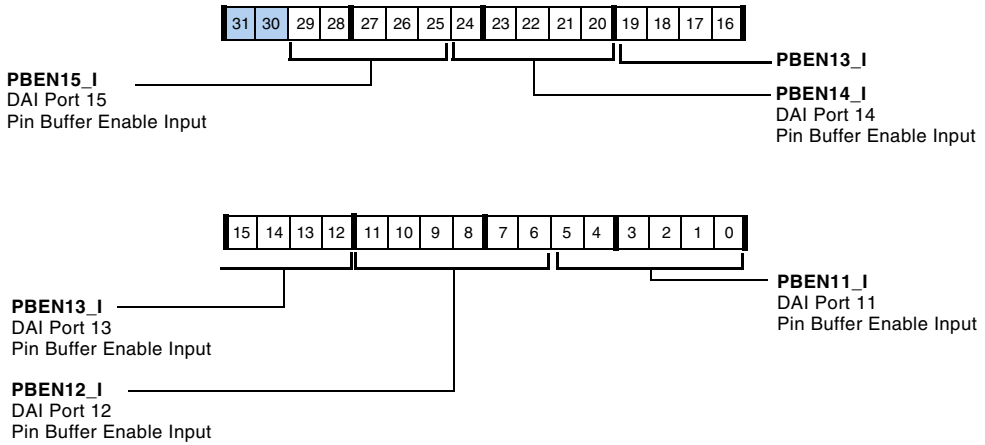

Figure A-42. SRU_PBEN2 (RW)

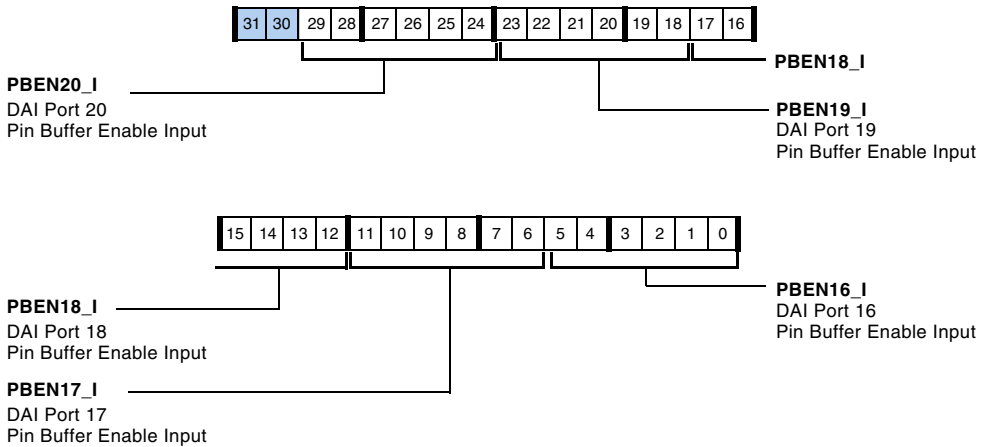

Figure A-43. SRU_PBEN3 (RW)

DAI Signal Routing Unit Registers

Table A-26. Group F Sources—Pin Output Enable

Selection Code	Source Signal	Description (Output source selection)
000000 (0x0)	LOW	logic level low (0)
000001 (0x1)	HIGH	logic level high (1)
000010 (0x2)	MISCA0_O	Miscellaneous control A0 output
000011 (0x3)	MISCA1_O	Miscellaneous control A1 output
000100 (0x4)	MISCA2_O	Miscellaneous control A2 output
000101 (0x5)	MISCA3_O	Miscellaneous control A3 output
000110 (0x6)	MISCA4_O	Miscellaneous control A4 output
000111 (0x7)	MISCA5_O	Miscellaneous control A5 output
001000 (0x8)	SPORT0_CLK_PBEN_O	SPORT 0 clock output enable
001001 (0x9)	SPORT0_FS_PBEN_O	SPORT 0 frame sync output enable
001010 (0xA)	SPORT0_DA_PBEN_O	SPORT 0 data channel A output enable
001011 (0xB)	SPORT0_DB_PBEN_O	SPORT 0 data channel B output enable
001100 (0xC)	SPORT1_CLK_PBEN_O	SPORT 1 clock output enable
001101 (0xD)	SPORT1_FS_PBEN_O	SPORT 1 frame sync output enable
001110 (0xE)	SPORT1_DA_PBEN_O	SPORT 1 data channel A output enable
001111 (0xF)	SPORT1_DB_PBEN_O	SPORT 1 data channel B output enable
010000 (0x10)	SPORT2_CLK_PBEN_O	SPORT 2 clock output enable
010001 (0x11)	SPORT2_FS_PBEN_O	SPORT 2 frame sync output enable
010010 (0x12)	SPORT2_DA_PBEN_O	SPORT 2 data channel A output enable
010011 (0x13)	SPORT2_DB_PBEN_O	SPORT 2 data channel B output enable
010100 (0x14)	SPORT3_CLK_PBEN_O	SPORT 3 clock output enable
010101 (0x15)	SPORT3_FS_PBEN_O	SPORT 3 frame sync output enable
010110 (0x16)	SPORT3_DA_PBEN_O	SPORT 3 data channel A output enable
010111 (0x17)	SPORT3_DB_PBEN_O	SPORT 3 data channel B output enable
011000 (0x18)	SPORT4_CLK_PBEN_O	SPORT 4 clock output enable
011001 (0x19)	SPORT4_FS_PBEN_O	SPORT 4 frame sync output enable

Table A-26. Group F Sources—Pin Output Enable (Cont'd)

Selection Code	Source Signal	Description (Output source selection)
011010 (0x1A)	SPORT4_DA_PBEN_O	SPORT 4 data channel A output enable
011011 (0x1B)	SPORT4_DB_PBEN_O	SPORT 4 data channel B output enable
011100 (0x1C)	SPORT5_CLK_PBEN_O	SPORT 5 clock output enable
011101 (0x1D)	SPORT5_FS_PBEN_O	SPORT 5 frame sync output enable
011110 (0x1E)	SPORT5_DA_PBEN_O	SPORT 5 data channel A output enable
011111 (0x1F)	SPORT5_DB_PBEN_O	SPORT 5 data channel B output enable
100000 (0x20)	SPORT6_CLK_PBEN_O	SPORT 6 clock output enable
100001 (0x21)	SPORT6_FS_PBEN_O	SPORT 6 frame sync output enable
100010 (0x22)	SPORT6_DA_PBEN_O	SPORT 6 data channel A output enable
100011 (0x23)	SPORT6_DB_PBEN_O	SPORT 6 data channel B output enable
100100 (0x24)	SPORT7_CLK_PBEN_O	SPORT 7 clock output enable
100101 (0x25)	SPORT7_FS_PBEN_O	SPORT 7 frame sync output enable
100110 (0x26)	SPORT7_DA_PBEN_O	SPORT 7 data channel A output enable
100111 (0x27)	SPORT7_DB_PBEN_O	SPORT 7 data channel B output enable
101000 (0x28)	SPORT0_TDV_PBEN_O	SPORT 0 transmit data valid output
101001 (0x29)	SPORT1_TDV_PBEN_O	SPORT 1 transmit data valid output
101010 (0x2A)	SPORT2_TDV_PBEN_O	SPORT 2 transmit data valid output
101011 (0x2B)	SPORT3_TDV_PBEN_O	SPORT 3 transmit data valid output
101100 (0x2C)	SPORT4_TDV_PBEN_O	SPORT 4 transmit data valid output
101101 (0x2D)	SPORT5_TDV_PBEN_O	SPORT 5 transmit data valid output
100111 (0x2E)	SPORT6_TDV_PBEN_O	SPORT 6 transmit data valid output
101110 (0x2F)	SPORT7_TDV_PBEN_O	SPORT 7 transmit data valid output
110000 (0x30)–111111 (0x3F)		Reserved

DAI Signal Routing Unit Registers

Pin Buffer Registers

The `DAI_PIN_PULLUP` and `DAI_PIN_STAT` control and return status of the DAI pin buffers.

Pin Buffer Status Registers (`DAI_PIN_STAT`)

The `DAI_PIN_STAT` register, shown in [Figure A-44](#), provides DAI pin level buffer status information. This register is updated at up to the `PCLK/2` rate.

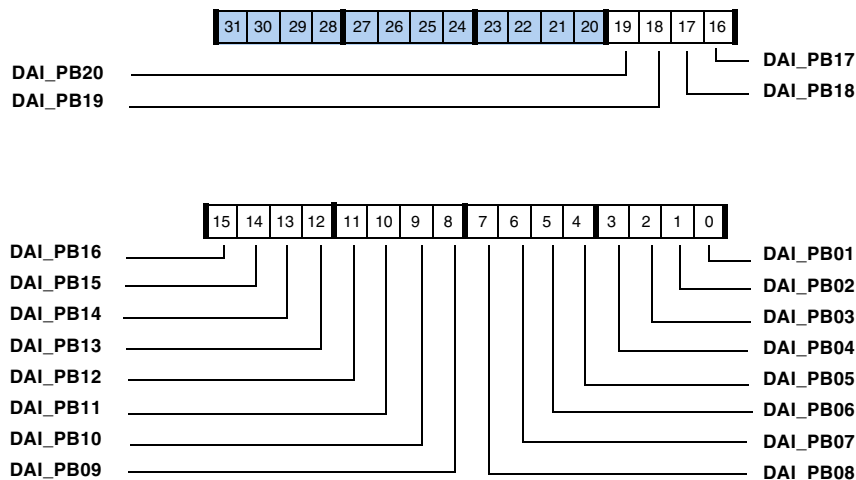

Figure A-44. `DAI_PIN_STAT` Register (RO)

Resistor Pull-up Enable Register (`DAI_PIN_PULLUP`)

This 20-bit, read/write register is shown in [Figure A-45](#). Bits 19–0 of this register control the enabling/disabling pull-up resistors on `DAI_P020-1`. Setting a bit to 1 enables a pull-up resistor on the corresponding pin. After RESET, all pull-ups are enabled on all 20 DAI pins.

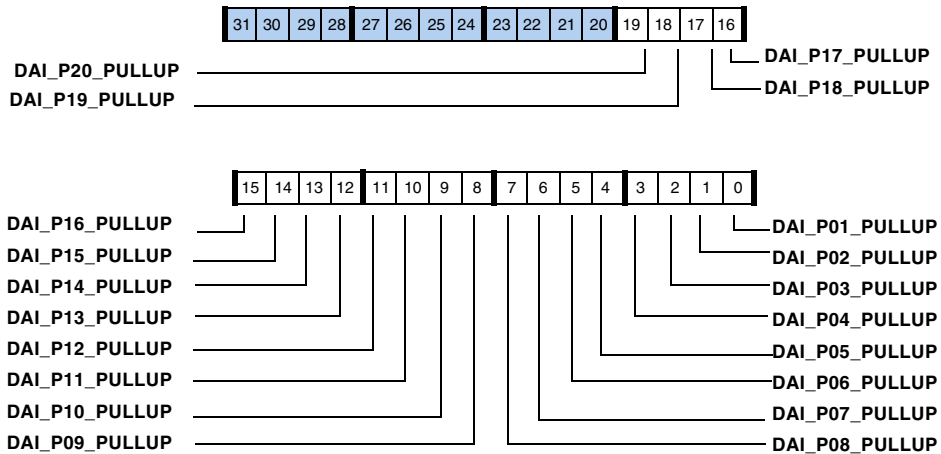

Figure A-45. DAI_PIN_PULLUP Register (RW)

Interrupt Controller Registers

All of the DAI interrupt registers are used primarily to provide the status of the resident interrupt controller. These registers are listed in [Table A-27](#) and shown in [Figure A-46](#). Note that for each of these registers the bit names and numbers are the same.

Table A-27. DAI Interrupt Registers

Register	Description
DAI_IRPTL_H (ROC)	High priority interrupt latch register
DAI_IRPTL_HS (RO)	Shadow high priority interrupt latch register
DAI_IRPTL_L (ROC)	Low priority interrupt latch register
DAI_IRPTL_LS (RO)	Shadow low priority interrupt latch register
DAI_IRPTL_PRI (RW)	Core interrupt priority assignment register
DAI_IMASK_RE (RW)	Rising edge interrupt mask register
DAI_IMASK_FE (RW)	Falling edge interrupt mask register

Peripherals Routed Through the DAI

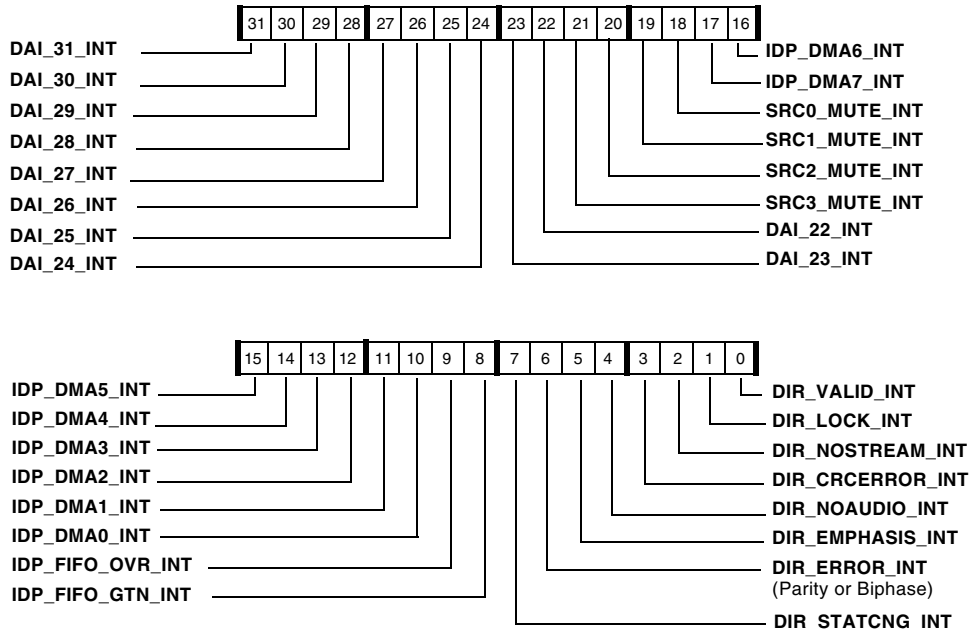

Figure A-46. DAI Interrupt Latch/Mask Register

Peripherals Routed Through the DAI

The following sections provide information on the peripherals that are explicitly routed through the digital applications interface. [For more information, see “DAI Signal Routing Unit Registers” on page A-40.](#)

Serial Port Registers

The following section describes serial port (SPORT) registers.

Divisor Registers (DIVx)

These registers, shown in [Figure A-47](#), allow programs to set the frame sync divisor and clock divisor in master mode.

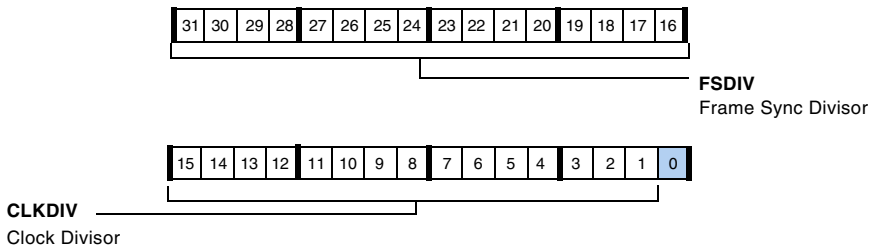

Figure A-47. DIVx Register (RW)

Serial Control Registers (SPCTLx)

The `SPCTLx` registers are transmit and receive control registers for the corresponding serial ports (SPORT 0 through 7). These registers change depending on operating mode. Figures and bit descriptions are provided as follows.

- Serial mode – [Figure A-48](#) and [Table A-28 on page A-73](#).
- I²S and Left-Justified modes – [Figure A-49 on page A-79](#) and [Table A-29 on page A-79](#).
- Packed and Multichannel mode – [Figure A-50 on page A-83](#) and [Table A-30 on page A-84](#).

Peripherals Routed Through the DAI

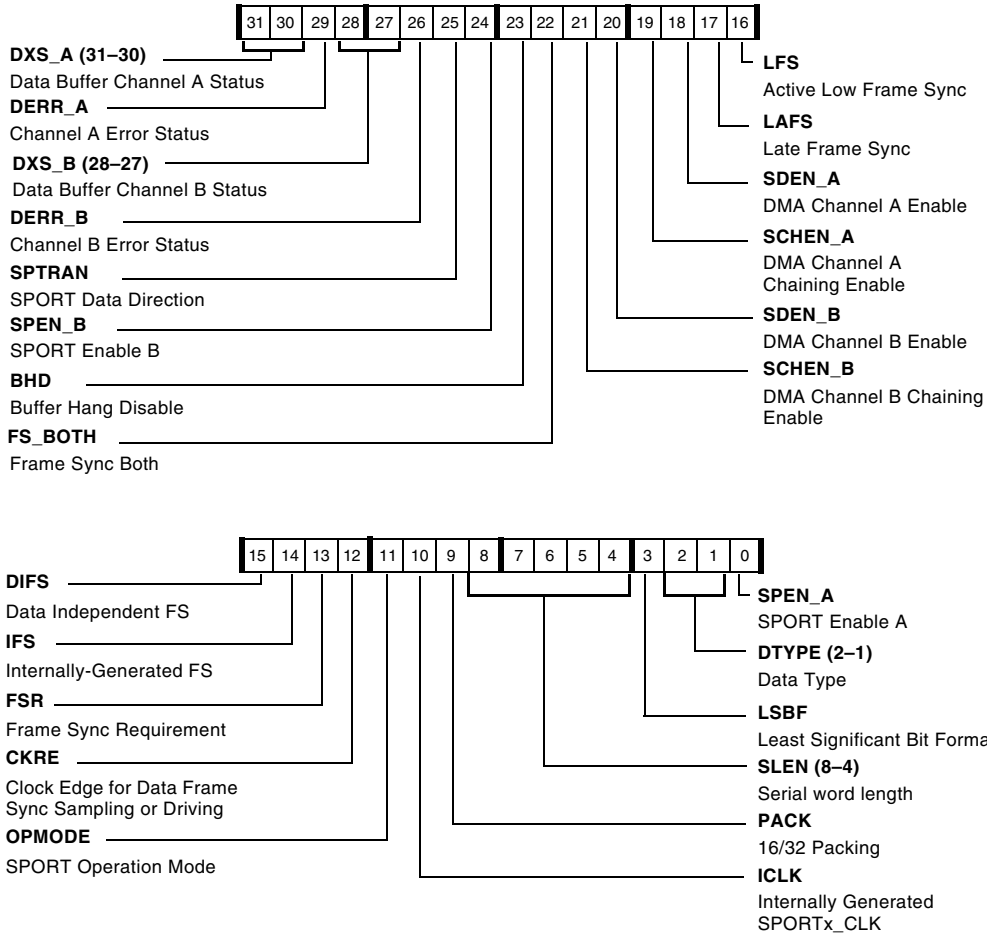

Figure A-48. SPCTLx Register for Serial Mode

Table A-28. SPCTLx Register Bit Descriptions (RW)
(Serial Mode)

Bit	Name	Description
0	SPEN_A	Enable Channel A Serial Port. 0 = Serial port A channel disabled 1 = Serial port A channel enabled
2–1	DTYPE	Data Type Select. Selects the data type formatting for standard serial mode transmissions. For Standard serial mode A channels, selection of companding mode and MSB format are exclusive: Serial Data Channel A Type Formatting 00 Right-justify, zero-fill unused MSBs 01 Right-justify, sign-extend unused MSBs 10 Compand using μ -law 11 Compand using A-law Serial Data Channel B Type Formatting For Standard serial mode B channels, companding mode is unavailable. 0 Right-justify, zero-fill unused MSBs 1 Right-justify, sign-extend unused MSBs The transmit buffer does not zero-fill or sign-extend transmit data words; this only takes place for the receive buffer.
3	LSBF	Serial Word Endian Select. Endian format determines whether serial words transmit MSB first or LSB first. 0 = Big endian (MSB first) 1 = Little endian (LSB first)
8–4	SLEN	Serial Word Length Select. Selects the word length in bits. The value of SLEN = serial word length. For DSP standard mode, word sizes can range from 3 bit (SLEN = 3) to 32 bits (SLEN = 32). Do not set the SLEN less than 3. Words smaller than 32 bits are right-justified in the receive and transmit buffers, residing in the least significant (LSB) bit positions.

Peripherals Routed Through the DAI

Table A-28. SPCTLx Register Bit Descriptions (RW)
(Serial Mode) (Cont'd)

Bit	Name	Description
9	PACK	<p>16-bit to 32-bit Word Packing Enable. When PACK = 1, two successive received words are packed into a single 32-bit word, and each 32-bit word is unpacked and transmitted as two 16-bit words. The first 16-bit (or smaller) word is right-justified in bits 15–0 of the packed word, and the second 16-bit (or smaller) word is right-justified in bits 31–16. This applies to both receive (packing) and transmit (unpacking) operations. Companding can be used with word packing or unpacking. When SPORT data packing is enabled, the transmit and receive interrupts are generated for the 32-bit packed words, not for each 16-bit word. Note that when 16-bit received data is packed into 32-bit words and stored in NW-word space in internal memory, the 16-bit words can be read or written with SW-space addresses.</p> <p>0 = Disable 16- to 32-bit word packing 1 = Enable 16- to 32-bit word packing</p>
10	ICLK	<p>Internal Clock Select. When ICLK is set (=1), the clock signal is generated internally by the processor and the SPORTx_CLK_O signals are outputs. The clock frequency is determined by the value of the serial clock divisor (CLKDIV) in the DIVx registers. When ICLK is cleared (=0), the clock signal is accepted as an input on the SPORTx-_CLK_I signals, and the serial clock divisors in the DIVx registers are ignored. Note the externally-generated serial clock does not need to be synchronous with the processor's system clock.</p> <p>0 = Select external transmit clock 1 = Select internal transmit clock</p>
11	OPMODE	<p>Sport Operation Mode.</p> <p>0 = DSP serial/multichannel mode if cleared</p>

Table A-28. SPCTLx Register Bit Descriptions (RW)
(Serial Mode) (Cont'd)

Bit	Name	Description
12	CKRE	<p>Clock Rising Edge Select. Determines clock signal to sample data and the frame sync selection. For sampling receive data and frame syncs, setting CKRE to 1 selects the rising edge of SPORTx_CLK. When CKRE is cleared (=0), the processor selects the falling edge of SPORTx_CLK for sampling receive data and frame syncs. Note that transmit data and frame sync signals change their state on the clock edge that is not selected.</p> <p>For example, the transmit and receive functions of any two SPORTs connected together should always select the same value for CKRE so internally-generated signals are driven on one edge and received signals are sampled on the opposite edge.</p> <p>0 = Falling edge 1 = Rising edge</p>
13	FSR	<p>Frame Sync Required Select. Selects whether the serial port requires (if set, = 1) or does not require a transfer frame sync (if cleared, = 0).</p>
14	IFS	<p>Internal Frame Sync Select. Selects whether the serial port uses an internally generated frame sync (if set, = 1) or uses an external frame sync (if cleared, = 0).</p>
15	DIFS	<p>Data Independent Frame Sync Select.</p> <p>1 = Serial port uses a data-independent frame sync (sync at selected interval) 0 = Serial port uses a data-dependent frame sync (sync when TX FIFO is not empty or when RX FIFO is not full).</p>
16	LFS	<p>Active Low Frame Sync Select. This bit selects the logic level of the (transmit or receive) frame sync signals. This bit selects an active low frame sync (if set, = 1) or active high frame sync (if cleared, = 0).</p>
17	LAFS	<p>Late Transmit Frame Sync Select. This bit selects when to generate the frame sync signal. This bit selects a late frame sync if set (= 1) during the first bit of each data word. This bit selects an early frame sync if cleared (= 0) during the serial clock cycle immediately preceding the first data bit</p> <p>0 = Early frame sync (FS before first bit) 1 = Late frame sync (FS during first bit)</p>

Peripherals Routed Through the DAI

Table A-28. SPCTLx Register Bit Descriptions (RW)
(Serial Mode) (Cont'd)

Bit	Name	Description
18	SDEN_A	Enable Channel A Serial Port DMA. 0 = Disable serial port channel A DMA 1 = Enable serial port channel A DMA
19	SCHEN_A	Enable Channel A Serial Port DMA Chaining. 0 = Disable serial port channel A DMA chaining 1 = Enable serial port channel A DMA chaining
20	SDEN_B	Enable Channel B Serial Port DMA. 0 = Disable serial port channel B DMA 1 = Enable serial port channel B DMA
21	SCHEN_B	Enable Channel B Serial Port DMA Chaining. 0 = Disable serial port channel B DMA chaining 1 = Enable serial port channel B DMA chaining
22	FS_BOTH	FS Both Enable. This bit applies when the SPORTS channels A and B are configured to transmit/receive data. If set (= 1), this bit issues frame sync only when data is present in both transmit buffers, TXSPxA and TXSPxB. If cleared (= 0), a frame sync is issued if data is present in either transmit buffers. When a SPORT is configured as a receiver, if FS_BOTH is set (= 1), frame sync is issued only when both the RX FIFOs (RXSPxA and RXSPxB) are not full. If only channel A or channel B is selected, the frame sync behaves as if FS_BOTH is cleared (= 0). If both A and B channels are selected, the word select acts as if FS_BOTH is set (= 1). 0 = Issue FS if data is present in either transmit/receive buffer. 1 = Issue FS if data is present in both transmit/receive buffers.
23	BHD	Buffer Hang Disable. 0 = Indicates a core stall. The core stalls when it tries to write to a full transmit buffer or read an empty receive buffer FIFO. 1 = Ignore a core hang
24	SPEN_B	Enable Channel B Serial Port. 0 = Serial port A channel disabled 1 = Serial port A channel enabled

Table A-28. SPCTLx Register Bit Descriptions (RW)
(Serial Mode) (Cont'd)

Bit	Name	Description
25	SPTRAN	<p>Data Direction Control. This bit controls the data direction of the serial port channel A and B signals.</p> <p>When cleared (= 0) the SPORT is configured to receive on both channels A and B. When configured to receive, the RXSPxA and RXSPxB buffers are activated, while the receive shift registers are controlled by SPORTx_CLK and SPORTx_FS. The TXSPxA and TXSPxB buffers are inactive.</p> <p>When set (= 1) the SPORT is configured to transmit on both channels A and B. When configured to transmit, the TXSPxA and TXSPxB buffers are activated, while the transmit shift registers are controlled by SPORTx_CLK and SPORTx_FS. The RXSPxA and RXSPxB buffers are inactive.</p>
26 (RO)	DERR_B	<p>Channel B Error Status (sticky). When the SPORT is configured as a transmitter, this bit provides transmit underflow status. If FSR = 1, DERR_x bit indicates whether the SPORTx_FS signal (from an internal or external source) occurred while the DXS_x buffer was empty. The SPORTs transmit data whenever they detect a SPORTx_FS signal.</p> <p>0 = No SPORTx_FS signal occurred while TXSPxA/B buffer is empty. 1 = SPORTx_FS signal occurred while TXSPxA/B buffer is empty.</p> <p>If FSR = 0, DERR_x is set whenever the SPORT is required to transmit and the transmit buffer is empty.</p> <p>When the SPORT is configured as a receiver, this bit provides receive overflow status. If FSR = 1, DERR_x bit indicates whether the SPORTx_FS signal (from an internal or external source) occurred while the DXS_x buffer was full. The SPORTs receive data whenever they detect a SPORTx_FS signal. As a receiver, it indicates when the channel has received new data while the receive buffer is full. New data overwrites existing data.</p> <p>0 = No SPORTx_FS signal occurred while RXSPxA/B buffer is full. 1 = SPORTx_FS signal occurred while RXSPxA/B buffer is full.</p> <p>If FSR = 0, DERR_x is set whenever the SPORT is required to receive and the receive buffer is full.</p>

Peripherals Routed Through the DAI

Table A-28. SPCTLx Register Bit Descriptions (RW)
(Serial Mode) (Cont'd)

Bit	Name	Description
28–27 (RO)	DXS_B	Channel B Data Buffer Status. Indicates the status of the serial port's channel B data buffer (RXSPxB or TXSPxB) as follows: 00 = Empty 10 = Partially full 11 = Full
29 (RO)	DERR_A	Channel A Error Status (sticky). Refer to DERR_B
31–30 (RO)	DXS_A	Channel A Data Buffer Status. Refer to DXS_B

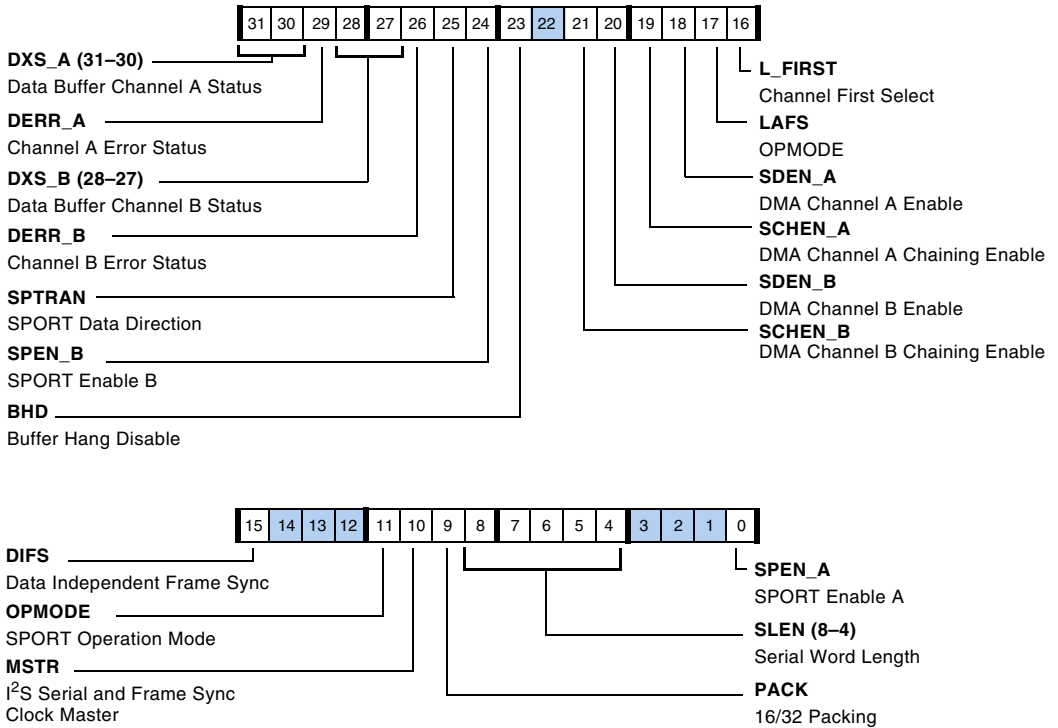

Figure A-49. SPCTLx Register for I²S and Left-Justified Modes

Table A-29. SPCTLx Register Bit Descriptions (RW) (I²S, Left-Justified)

Bit	Name	Description
0	SPEN_A	Enable Channel A Serial Port. 0 = Serial port A channel disabled 1 = Serial port A channel enabled
3–1	Reserved	
8–4	SLEN	Serial Word Length Select. Selects the word length in bits. Word sizes can be from 8 bits to 32 bits.

Peripherals Routed Through the DAI

Table A-29. SPCTLx Register Bit Descriptions (RW) (I²S, Left-Justified) (Cont'd)

Bit	Name	Description
9	PACK	16-bit to 32-bit Word Packing Enable. 0 = Disable 16- to 32-bit word packing 1 = Enable 16- to 32-bit word packing
10	MSTR	Master Clock and Frame Sync Select. 0 = Select external clock and FS 1 = Select internal clock and FS
11	OPMODE	Sport Operation Mode. 1 = Selects the I ² S or left-justified mode. Bit 17 is used to select either of both modes.
14–12	Reserved	
15	DIFS	Data Independent Frame Sync Select. 0 = Serial port uses a data-dependent frame sync (sync when TX FIFO is not empty or when RX FIFO is not full). 1 = Serial port uses a data-independent frame sync (sync at selected interval)
16	L_FIRST	Left-Justified/I²S Mode Channel Order Select. Selects left or right channel word first after valid edge. For left justified mode channel order: 0 = first data after the rising edge 1 = first data after the falling edge For I ² S mode channel order: 0 = first data after the falling edge 1 = first data after the rising edge
17	OPMODE (LAFS)	Operation Mode (IS or Left-Justified Mode Select). 0 = I ² S mode 1 = Left-justified mode
18	SDEN_A	Enable Channel A Serial Port DMA. 0 = Disable serial port channel A DMA 1 = Enable serial port channel A DMA
19	SCHEN_A	Enable Channel A Serial Port DMA Chaining. 0 = Disable serial port channel A DMA chaining 1 = Enable serial port channel A DMA chaining

Table A-29. SPCTLx Register Bit Descriptions (RW) (I²S, Left-Justified) (Cont'd)

Bit	Name	Description
20	SDEN_B	Enable Channel B Serial Port DMA. 0 = Disable serial port channel B DMA 1 = Enable serial port channel B DMA
21	SCHEN_B	Enable Channel B Serial Port DMA Chaining. 0 = Disable serial port channel B DMA chaining 1 = Enable serial port channel B DMA chaining
22	Reserved	
23	BHD	Buffer Hang Disable. 0 = Indicates a core stall. The core stalls when it tries to write to a full transmit buffer or read an empty receive buffer FIFO. 1 = Ignore a core hang
24	SPEN_B	Enable Channel B Serial Port. 0 = Serial port A channel disabled 1 = Serial port A channel enabled
25	SPTRAN	Data Direction Control. This bit controls the data direction of the serial port channel A and B signals. When cleared (= 0) the SPORT is configured to receive on both channels A and B. When configured to receive, the RXSPxA and RXSPxB buffers are activated, while the receive shift registers are controlled by SPORTx_CLK and SPORTx_FS. The TXSPxA and TXSPxB buffers are inactive. When set (= 1) the SPORT is configured to transmit on both channels A and B. When configured to transmit, the TXSPxA and TXSPxB buffers are activated, while the transmit shift registers are controlled by SPORTx_CLK and SPORTx_FS. The RXSPxA and RXSPxB buffers are inactive.

Peripherals Routed Through the DAI

Table A-29. SPCTLx Register Bit Descriptions (RW) (I²S, Left-Justified) (Cont'd)

Bit	Name	Description
26 (RO)	DERR_B	<p>Channel B Error Status (sticky). SPORT configured as a transmitter, this bit provides transmit underflow status. As a transmitter, DERR_x bit indicates whether the SPORTx_FS signal (from an internal or external source) occurred while the DXS_x buffer was empty. The SPORTs transmit data whenever they detect a SPORTx_FS signal. 0 = No SPORTx_FS signal occurred while TXSPxA/B buffer is empty. 1 = SPORTx_FS signal occurred while TXSPxA/B buffer is empty.</p> <p>SPORT configured as a receiver, these bits provide receive overflow status. As a receiver, DERR_x bit indicates whether the SPORTx_FS signal (from an internal or external source) occurred while the DXS_x buffer was full. The SPORTs receive data whenever they detect a SPORTx_FS signal. As a receiver, it indicates when the channel has received new data while the receive buffer is full. New data overwrites existing data. 0 = No SPORTx_FS signal occurred while RXSPxA/B buffer is full. 1 = SPORTx_FS signal occurred while RXSPxA/B buffer is full.</p>
28–27 (RO)	DXS_B	<p>Channel B Data Buffer Status. Indicates the status of the SPORT's channel B data buffer (RXSPxB or TXSPxB) as follows: 00 = Empty, 10 = Partially full, 11 = Full</p>
29 (RO)	DERR_A	Channel A Error Status (sticky). Refer to DERR_B
31–30 (RO)	DXS_A	Channel A Data Buffer Status. Refer to DXS_B

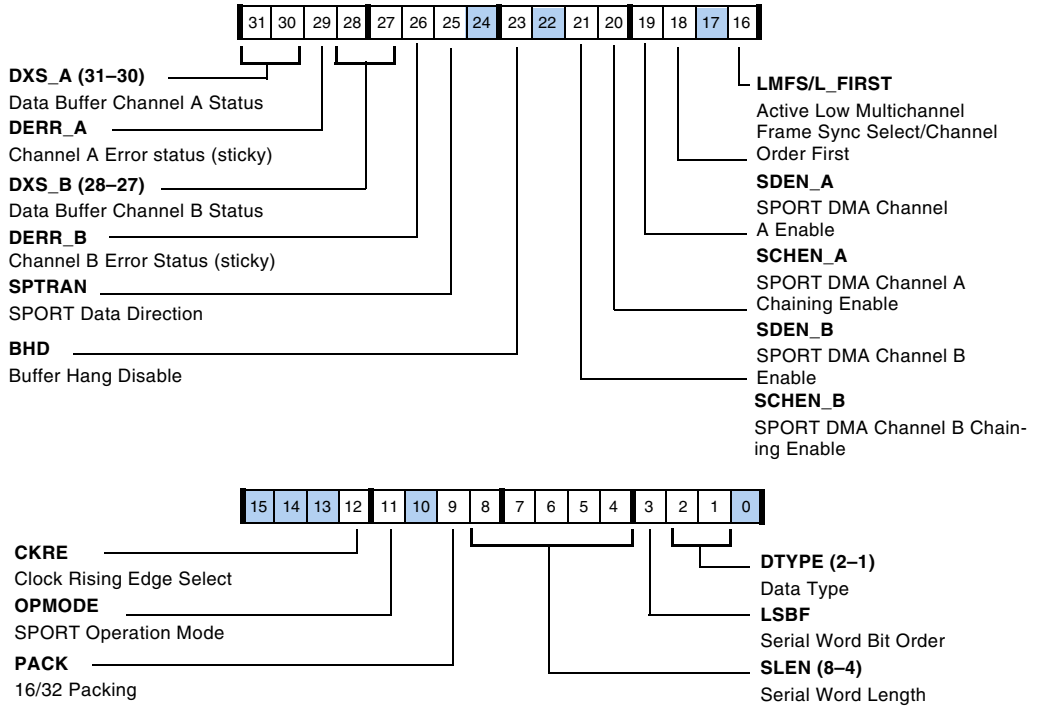

Figure A-50. SPCTLx Register – Packed and Multichannel Mode

Peripherals Routed Through the DAI

Table A-30. SPCTLx Register Bit Descriptions (RW) (Packed and Multichannel)

Bit	Name	Description
0	Reserved	
2–1	DTYPE	<p>Data Type Select. Selects the data type formatting for standard serial mode transmissions. For Standard serial mode A channels, selection of companding mode and MSB format are exclusive:</p> <p>Serial Data Channel A Type Formatting</p> <p>00 Right-justify, zero-fill unused MSBs</p> <p>01 Right-justify, sign-extend unused MSBs</p> <p>10 Compand using μ-law</p> <p>11 Compand using A-law</p> <p>For Standard serial mode B channels, companding mode is not available</p> <p>Serial Data Channel B Type Formatting</p> <p>0 Right-justify, zero-fill unused MSBs</p> <p>1 Right-justify, sign-extend unused MSBs</p> <p>The transmit buffer does not zero-fill or sign-extend transmit data words; this only takes place for the receive buffer.</p>
3	LSBF	<p>Serial Word Endian Select.</p> <p>0 = Big endian (MSB first)</p> <p>1 = Little endian (LSB first)</p>
8–4	SLEN	<p>Serial Word Length Select. Selects the word length in bits. Word sizes can be from 3 bits to 32 bits.</p>
9	PACK	<p>16-bit to 32-bit Word Packing Enable.</p> <p>0 = Disable 16- to 32-bit word packing</p> <p>1 = Enable 16- to 32-bit word packing</p>
10	ICLK	<p>Internal Clock Select. Select the SPORT clock.</p> <p>0 = Select external clock</p> <p>1 = Select internal clock</p>
11	OPMODE	<p>Sport Operation Mode.</p> <p>0 = Multichannel mode</p> <p>1 = Packed mode</p> <p>Note for multichannel operation, the SPMCTLx registers must be programmed</p>

Table A-30. SPCTLx Register Bit Descriptions (RW) (Packed and Multichannel) (Cont'd)

Bit	Name	Description
12	CKRE	Clock Rising Edge Select. Determines clock signal to sample data and the frame sync selection. 0 = Falling edge 1 = Rising edge
13	Reserved	
14	IMFS	Internal Multichannel Frame Sync Select. Selects whether the serial port uses an internally generated frame sync (if set, = 1) or uses an external frame sync (if cleared, = 0).
15	Reserved	
16	LMFS/L_FIRST	Active Level TDM Frame Sync/Channel Order First. For TDM mode this bit (LMFS) selects the logic level of the (transmit or receive) frame sync signals. 0 = active low frame sync 1 = active high frame sync For Packed Mode, this bit (L_FIRST) selects left or right channel word first after valid edge. 0 = first data after the falling edge 1 = first data after the rising edge
17	Reserved	
18	SDEN_A	Enable Channel A Serial Port DMA. 0 = Disable serial port channel A DMA 1 = Enable serial port channel A DMA
19	SCHEN_A	Enable Channel A Serial Port DMA Chaining. 0 = Disable serial port channel A DMA chaining 1 = Enable serial port channel A DMA chaining
20	SDEN_B	Enable Channel B Serial Port DMA. 0 = Disable serial port channel B DMA 1 = Enable serial port channel B DMA
21	SCHEN_B	Enable Channel B Serial Port DMA Chaining. 0 = Disable serial port channel B DMA chaining 1 = Enable serial port channel B DMA chaining
22	Reserved	

Peripherals Routed Through the DAI

Table A-30. SPCTLx Register Bit Descriptions (RW) (Packed and Multichannel) (Cont'd)

Bit	Name	Description
23	BHD	Buffer Hang Disable. 0 = Indicates a core stall. The core stalls when it tries to write to a full transmit buffer or read an empty receive buffer FIFO. 1 = Ignore a core hang
24	Reserved	
25	SPTRAN	Data Direction Control. This bit controls the data direction of the serial port channel A and B signals. When cleared (= 0) the SPORT is configured to receive on both channels A and B. When configured to receive, the RXSPxA and RXSPxB buffers are activated, while the receive shift registers are controlled by SPORTx_CLK and SPORTx_FS. The TXSPxA and TXSPxB buffers are inactive. When set (= 1) the SPORT is configured to transmit on both channels A and B. When configured to transmit, the TXSPxA and TXSPxB buffers are activated, while the transmit shift registers are controlled by SPORTx_CLK and SPORTx_FS. The RXSPxA and RXSPxB buffers are inactive.
26 (RO)	DERR_B	Channel B Error Status (sticky). When the SPORT is configured as a transmitter, this bit provides transmit underflow status. As a transmitter DERR_x bit indicates whether the SPORTx_FS signal (from an internal or external source) occurred while the DXS_x buffer was empty. The SPORTs transmit data whenever they detect a SPORTx_FS signal. 0 = No SPORTx_FS signal occurred while TXSPxA/B buffer is empty. 1 = SPORTx_FS signal occurred while TXSPxA/B buffer is empty. When the SPORT is configured as a receiver, these bits provide receive overflow status. As a receiver, DERR_x bit indicates whether the SPORTx_FS signal (from an internal or external source) occurred while the DXS_x buffer was full. The SPORTs receive data whenever they detect a SPORTx_FS signal. As a receiver, it indicates when the channel has received new data while the receive buffer is full. New data overwrites existing data. 0 = No SPORTx_FS signal occurred while RXSPxA/B buffer is full. 1 = SPORTx_FS signal occurred while RXSPxA/B buffer is full.

Table A-30. SPCTLx Register Bit Descriptions (RW) (Packed and Multichannel) (Cont'd)

Bit	Name	Description
28–27 (RO)	DXS_B	Channel B Data Buffer Status. Indicates the status of the serial port's receive channel B data buffer as follows: 00 = Empty 10 = Partially full 11 = Full
29 (RO)	DERR_A	Channel A Error Status (sticky). Indicates if the serial receive operation has overflowed in the channel A data buffer.
31–30 (RO)	DXS_A	Channel A Data Buffer Status. Indicates the status of the serial port's receive channel A data buffer as follows: 00 = Empty 10 = Partially full 11 = Full

Multichannel Control Registers (SPMCTLx)

Unlike previous SHARC designs, the serial ports in the ADSP-21367/8/9 and ADSP-2137x processors work individually, not in pairs. Therefore, each SPORT has its own multichannel control register. These registers are shown in [Figure A-51](#) and described in [Table A-31](#).

Note that in previous ADSP-2136x SHARC processors there is one SPMCTL_{xy} register for each multichannel SPORT pair. In order to support legacy programming models, the new SPORT multichannel registers keep the same bit settings.

For example the legacy SPMCTL01 register for SPORT pair 01 has the same bits as the new SPMCTL0 register or SPMCTL1 register. Both registers can be used for the same TDM programming. In the new SPMCTL_x register x denotes the even SPORT number and y denotes the odd SPORT number. To make ADSP-2136x programs compatible, run the even numbered SPORT in transmit mode and the odd numbered SPORT in receive mode.

Peripherals Routed Through the DAI

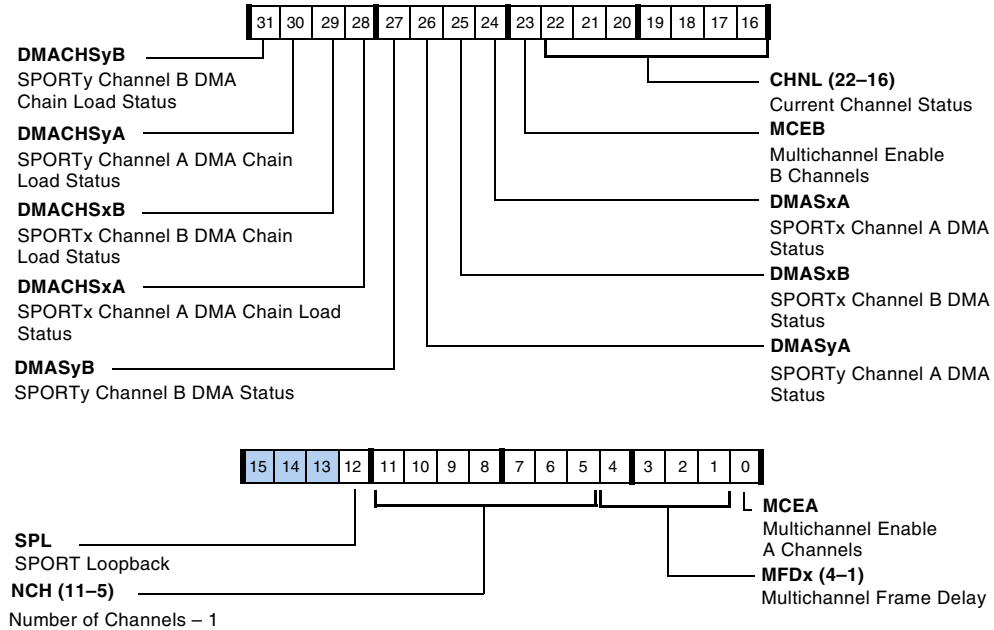

Figure A-51. SPMCTLx Registers – Multichannel Mode

Table A-31. SPMCTLx Register Bit Descriptions (RW)

Bit	Name	Description
0	MCEA	<p>Multichannel A Mode Enable. Packed and multichannel A modes only. One of two configuration bits that enable and disable multichannel mode on serial port channels. See OPMODE bit (17).</p> <p>0 = Disable multichannel A operation 1 = Enable multichannel A operation/packed mode</p> <p>Note if MCEA bit is set, the corresponding SPEN_A bit in the SPCTL register should be cleared.</p>
4–1	MFD	<p>Multichannel Frame Delay. Set the interval, in number of serial clock cycles, between the multichannel frame sync pulse and the first data bit. These bits provide support for different types of T1 interface devices. Valid values range from 0 to 15 with bits 4–1. Values of 1 to 15 correspond to the number of intervening serial clock cycles. A value of 0 corresponds to no delay. The multichannel frame sync pulse is concurrent with first data bit.</p>
11–5	NCH	<p>Number of Multichannel Slots (minus one). Select the number of channel slots (maximum of 128) to use for multichannel operation. Valid values for actual number of channel slots range from 1 to 128. Use this formula to calculate the value for NCH:</p> $NCH = \text{Actual number of channel slots} - 1.$

Peripherals Routed Through the DAI

Table A-31. SPMCTLx Register Bit Descriptions (RW) (Cont'd)

Bit	Name	Description
12	SPL	<p>SPORT Loopback Mode. Enables if set (= 1) or disables if cleared (= 0) the channel loopback mode. Loopback mode enables debug capabilities. Loopback works under the following SPORT configurations where either of the two paired SPORTs can be set up to transmit or receive, depending on their SPTRAN bit setting. Only the transmitter acts as master to generate the clock and frame sync. The SPL bit applies to all non multichannel modes.</p> <p>SPORT0 and SPORT1. SPORT0 can only be paired with SPORT1, controlled by the SPL bit in the SPMCTL0/1 registers.</p> <p>SPORT2 and SPORT3. SPORT2 can only be paired with SPORT3, controlled by the SPL bit in the SPMCTL2/3 registers.</p> <p>SPORT4 and SPORT5. SPORT4 can only be paired with SPORT5, controlled by the SPL bit in the SPMCTL4/5 registers.</p> <p>SPORT6 and SPORT7. SPORT6 can only be paired with SPORT7, controlled via SPL bit in the SPMCTL6/7 registers.</p>
15–13	Reserved	
22–16 (RO)	CHNL	Current Channel Selected (sticky). Identify the currently selected transmit channel slot (0 to 127).
23	MCEB	<p>Multichannel B Mode Enable. Packed and multichannel B modes only. One of two configuration bits that enable and disable multichannel mode on serial port channels. See OPMODE bit (17). 0 = Disable multichannel B operation 1 = Enable multichannel B operation/packed mode Note if MCEB bit is set, the corresponding SPEN_B bit in the SPCTL register should be cleared.</p>
24 (RO)	DMASxA	<p>DMA x Status Channel A. Selects the transfer status. 0 = Inactive 1 = Active</p>

Table A-31. SPMCTLx Register Bit Descriptions (RW) (Cont'd)

Bit	Name	Description
25 (RO)	DMASyA	DMA x Status Channel B. Selects the transfer status. 0 = Inactive 1 = Active
26 (RO)	DMASyA	DMA y Status Channel A. Selects the transfer status. 0 = Inactive 1 = Active
27 (RO)	DMASyB	DMA y Status Channel B. Selects the transfer status. 0 = Inactive 1 = Active
28 (RO)	DMACHSxA	DMA x Chaining Status Channel A. Selects the transfer status. 0 = Inactive 1 = Active
29 (RO)	DMACHSxB	DMA x Chaining Status Channel B. Selects the transfer status. 0 = Inactive 1 = Active
30 (RO)	DMACHSyA	DMA y Chaining Status Channel A. Selects the transfer status. 0 = Inactive 1 = Active
31 (RO)	DMACHSyB	DMA y Chaining Status Channel B. Selects the transfer status. 0 = Inactive 1 = Active

Multichannel Active Channel Select Registers

Each bit, 31–0, set (=1) in one of the four MTxCS0, MTxCS1, and MTxCS2, for SPORT0/2/4/6 and MRxCS0, MRxCS1, MRxCS2, and MRxCS3 for SPORT1/3/5/7 registers corresponds to the active channel, 127–0, on a multichannel mode serial port. When these registers activate a channel (by setting the respective bits in these registers to 1), the serial port transmits or receives the word in that channel's position of the data stream. When a channel's bit in these registers is cleared (=0), the SPORT's data transmit pin three-states during the channel's transmit time slot if the serial port is

Peripherals Routed Through the DAI

configured as transmitter. If configured as the receiver it ignores the incoming data.

Note the compansion feature is hard coded. For compression (TX) the even numbered SPORTA channels must be used. For expansion (RX) the odd numbered SPORTA channels must be used.

Transmit Channel Select Registers (MTxCSy)

Each bit, 31–0, set (= 1) in one of four MTxCSy registers corresponds to an active transmit channel, 127–0, on a multichannel mode serial port. When the MTxCSy registers activate a channel, the serial port transmits the word in that channel's position of the data stream. When a channel's bit in the MTxCSy register is cleared (= 0), the serial port's data transmit pin three-states during the channel's transmit time slot. Note that the transmit data valid signal (SPORTx_TDV_0) is asserted if any transmit slots are enabled in any of the transmit registers.

Transmit Channel Compand Select Registers (MTxCCSy)

Each bit, 31–0, set (= 1) in one of four MTxCCSy registers corresponds to a companded transmit channel, 127–0, on a multichannel mode serial port. When the MTxCCSy register activates companding for a channel, the serial port applies the companding from the DTYPE selection to the transmitted word in that channel's position of the data stream. When a channel's bit in the MTxCCSy register is cleared (= 0), the serial port does not compand the output during the channel's receive time slot.

Receive Channel Select Registers (MRxCSy)

Each bit, 31–0, set (= 1) in one of the four MRxCSy registers corresponds to an active receive channel, 127–0, on a multichannel mode serial port. When the MRxCSy register activates a channel, the serial port receives the word in that channel's position of the data stream and loads the word into the RXSPx buffer. When a channel's bit in the MRxCSy register is cleared

(= 0), the serial port ignores any input during the channel’s receive time slot.

Receive Compand Channel Select Registers (MRxCCSy)

Each bit, 31–0, set (= 1) in the MRxCCSy registers corresponds to a companded receive channel, 127–0, on a multichannel mode serial port. When one of the four MRxCCSy registers activate companding for a channel, the serial port applies the companding from the DTYPE selection to the received word in that channel’s position of the data stream. When a channel’s bit in the MRxCCSy registers are cleared (= 0), the serial port does not compand the input during the channel’s receive time slot.

Error Control Register (SPERRCTLx)

The SPERRCTLx registers control and report the status of the interrupts generated by each SPORT (see [Figure A-52](#), [Table A-32](#)).

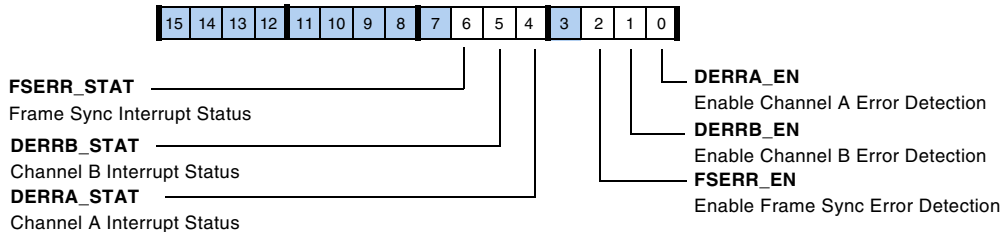

Figure A-52. SPERRCTLx Register

Table A-32. SPERRCTLx Register Bit Descriptions (RW)

Bit	Name	Description
0	DERRA_EN	Enable Channel A Error Detection. 0 = Disable 1 = Enable
1	DERRB_EN	Enable Channel B Error Detection. 0 = Disable 1 = Enable

Peripherals Routed Through the DAI

Table A-32. SPERRCTLx Register Bit Descriptions (RW) (Cont'd)

Bit	Name	Description
2	FSERR_EN	Enable Frame Sync Error Detection. 0 = Disable 1 = Enable
3	Reserved	
4 (W1C)	DERRA_STAT	Channel A Interrupt Status. Clears the DERR_A bits. SPTRAN = 0 Receive overflow status SPTRAN = 1 Transmit underflow status
5 (W1C)	DERRB_STAT	Channel B Interrupt Status. Clears the DERR_B bits. SPTRAN=0 Receive overflow status SPTRAN=1 Transmit underflow status
6 (W1C)	FSERR_STAT	Frame Sync Interrupt Status. 0 = No frame sync error 1 = Frame sync error detected

Error Status Register (SPERRSTAT)

The SPERRSTAT register checks the status of all SPORT7–0 interrupts. This allows to programs to check the status of all SPORTs using only one register (see [Figure A-53](#)).

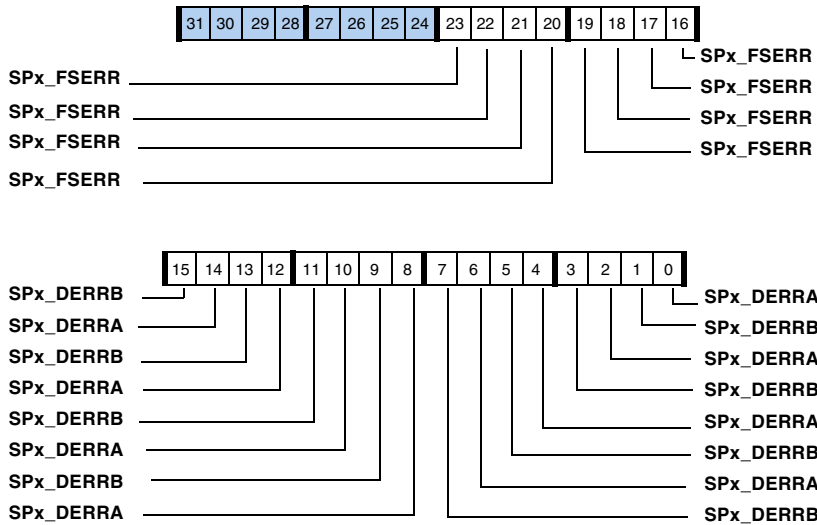

Figure A-53. SPERRSTAT Register (RO)

Input Data Port Registers

The input data port (IDP) provides an additional input path to the processor core. The IDP can be configured as 8 channels of serial data or 7 channels of serial data and a single channel of up to a 20-bit wide parallel data.

Serial Input Port Control Register 0 (IDP_CTL0)

Use this register to configure and enable the IDP and each of its channels. The register is shown in [Figure A-54](#) and described in [Table A-33](#).

Peripherals Routed Through the DAI

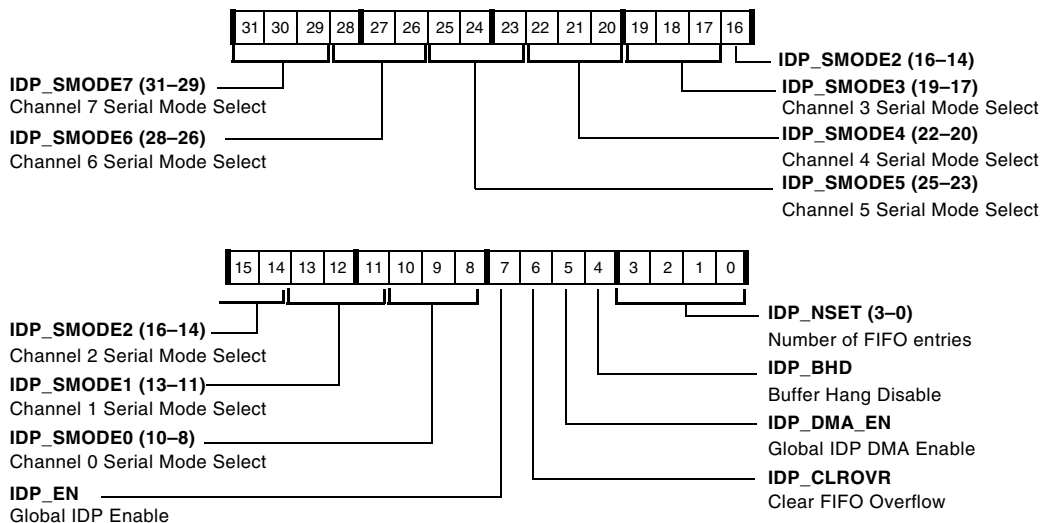

Figure A-54. IDP_CTL0 Register

Table A-33. IDP_CTL0 Register Bit Descriptions (RW)

Bits	Name	Description
3-0	IDP_NSET	Threshold Interrupt. The contents of the IDP_NSET bits represent a threshold number of entries (N) in the FIFO. When the FIFO fills to a point where it has more (N+1) than N words (data in FIFO exceeds the value set in the IDP_NSET bit field), a DAI interrupt is generated. This DAI interrupt corresponds to the IDP_FIFO_GTN_INT bit in DAI_IMASK_x registers. Only the core can use this N threshold interrupt to detect when data needs to be read. The maximum IDP_NSET= 7, otherwise no interrupt is generated.
4	IDP_BHD	IDP Buffer Hang Disable. Reads of an empty FIFO or writes to a full FIFO to cause a core hang. This condition continues until the FIFO has valid data (in the case of reads) or the FIFO has at least one empty location (in the case of writes). Note this can be used in debug operations. 0 = Core hang is enabled 1 = Core hang is disabled

Table A-33. IDP_CTL0 Register Bit Descriptions (RW) (Cont'd)

Bits	Name	Description
5	IDP_DMA_EN	DMA Enable. Enables DMA on all IDP channels. This bit is the global control for standard and ping-pong DMA. 0 = Channel disabled 1 = Channel enabled
6 (WOC)	IDP_CLROVR	FIFO Overflow Clear Bit. Clears the SRU_OVFX bits.
7	IDP_EN	Enable IDP. This bit enables the IDP. This is a global control bit. This bit needs to be set for all operations modes including DMA. When this bit is cleared (= 0), the IDP is disabled, and data cannot move to the IDP_FIFO. Writing a 1 to bit 31 of the IDP_CTL1 register also flushes the FIFO. To enable the IDP for DMA, two separate bits in two different registers must be set. The first are the global IDP_EN and IDP_DMA_EN bits in the IDP_CTL0 register and the second are the specific channel enable bits, located in the IDP_CTL1 register.
10–8	IDP_SMODE0	Serial Input Data Format Mode Select. These eight inputs (0–7), each of which contains 3 bits, indicate the mode of the serial input for each of the eight IDP channels. Input format: 000 = Left-justified 24 bits 001 = I ² S mode 24 bits 010 = Left-justified 32 bits 011 = I ² S 32 bits 100 = Right-justified 24 bits 101 = Right-justified 20 bits 110 = Right-justified 18 bits 111 = Right-justified 16 bits Note the SMODEx bits define the IDP buffer input format for core access. For I2S and left-justified single channel modes, it receives 32 bits of data from the SDATA pins. No L/R bit is added in these modes.
13–11	IDP_SMODE1	
16–14	IDP_SMODE2	
19–17	IDP_SMODE3	
22–20	IDP_SMODE4	
25–23	IDP_SMODE5	
28–26	IDP_SMODE6	
31–29	IDP_SMODE7	

Peripherals Routed Through the DAI

Serial Input Port Control Register 1 (IDP_CTL1)

Use the IDP_CTL1 register to configure and enable individual IDP channels. The register is shown in Figure A-55 and described in Table A-34.

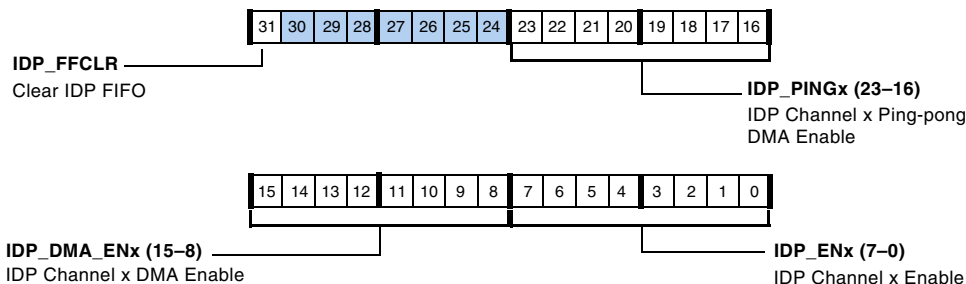

Figure A-55. IDP_CTL1 Register

Table A-34. IDP_CTL1 Register Bit Descriptions (RW)

Bit	Name	Description
7-0	IDP_ENx	IDP Channel x Enable. These are the enable bits for accepting data from individual channels. Corresponding IDP_ENx must be set with IDP_EN bit to get data from channel x. If IDP_EN bit is not set then this bit has no effect. 0x00 = All channels cleared 0xFF = All channels enabled (default)
15-8	IDP_DMA_ENx	IDP DMA Enable. These are the DMA enable bits for individual channels. Corresponding IDP_DMA_ENx must be set with IDP_DMA_EN bit for DMA transfer of data from channel x. If the global DMA_EN bit is not set then this bit has no effect. 0x00 = All channels cleared 0xFF = All channels enabled (default)
23-16	IDP_PINGx	IDP Ping-Pong DMA Channel x Enable. These are the Ping-Pong DMA enable bits for individual channels. Corresponding IDP_PINGx must be set to start ping-pong DMA from channel x. This bit requires the IDP_DMA_ENx bit and IDP_DMA_EN bit are set.

Table A-34. IDP_CTL1 Register Bit Descriptions (RW) (Cont'd)

Bit	Name	Description
30–24	Reserved	
31 (WOC)	IDP_FFCLR	Clear IDP FIFO. Setting this bit to 1 clears the IDP FIFO and the IDP_FIFOSZ bits. Note that when the IDP_EN bit transitions from 1 to 0, all data in the IDP FIFO are flushed.

Parallel Data Acquisition Port Control Register (IDP_PP_CTL)

The IDP_PP_CTL register (shown in [Figure A-56](#) and described in [Table A-35](#)) provides 20 mask bits that allow the input from any of the 20 pins to be ignored.

For more information on the operation of the parallel data acquisition port, see “[Programming Model](#)” on page 8-27. For information on the pin muxing that is used in conjunction with this module, see “[External Port Pin Multiplexing](#)” on page 17-28.

Peripherals Routed Through the DAI

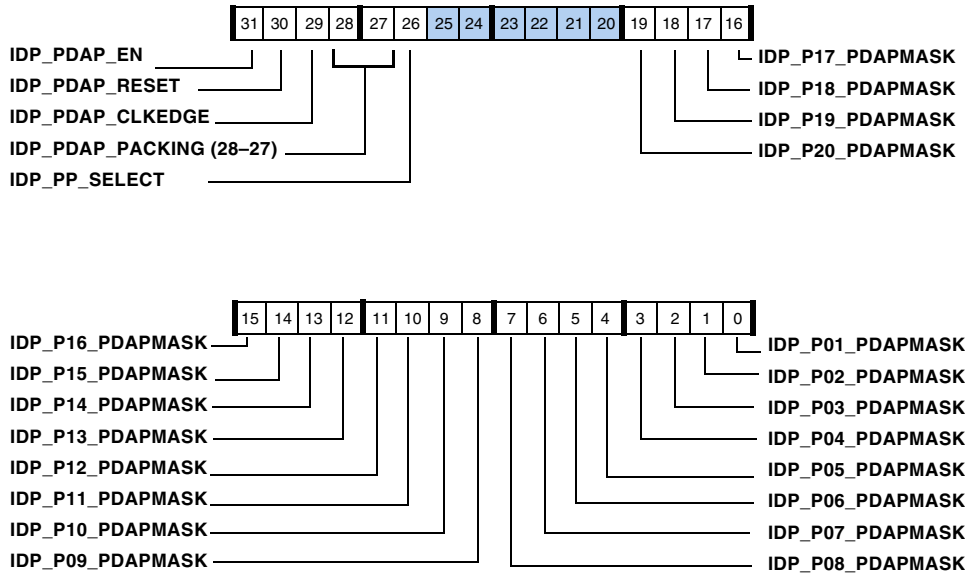

Figure A-56. IDP_PP_CTL Register

Table A-35. IDP_PP_CTL Register Bit Descriptions (RW)

Bit	Name	Description
19–0	IDP_P20–1_PDAPMASK	PDAP Data Mask. For each of the parallel inputs: 0 = Input data from PDAP_20-1 are masked (data is not read) 1 = Input data from PDAP_20-1 are unmasked After this masking process, data gets passed along to the packing unit.
25–20	Reserved	
26	IDP_PP_SELECT	PDAP Port Select. This bit selects which peripheral is connected to the PDAP unit. 0 = Data/control bits are read from DAI pins 1 = Data/control bits are read from external port pins

Table A-35. IDP_PP_CTL Register Bit Descriptions (RW) (Cont'd)

Bit	Name	Description
28–27	IDP_PDAP_PACKING	<p>Packing. Selects PDAP packing mode. These bits mask parallel sub words from the 20 parallel input signals and packs them into a 32-bit word. The bit field indicates how data is packed. Selection of packing mode is made based on the application.</p> <p>00 = 8- to 32-bit (packing by 4) 01 = (11, 11, 10) to 32-bit (packing by 3) 10 = 16- to 32-bit (packing by 2) 11 = 20- to 32-bit (no packing). 12 LSBs are cleared</p> <p>Note for input data width less than 20-bits, inputs are aligned to MSB pins.</p>
29	IDP_PDAP_CLKEDGE	<p>PDAP (Rising or Falling) Clock Edge.</p> <p>0 = Latch data on rising edge 1 = Latch data on falling edge</p> <p>Notice that in all four packing modes described, data is read on a clock edge, but the specific edge used (rising or falling) is not indicated.</p>
30 (WO)	IDP_PDAP_RESET	<p>PDAP Reset. A reset clears any data in the packing unit waiting to get latched into the IDP FIFO. This bit reset the counter of the PDAP and is useful for packing alignment. This bit always returns a value of zero when read.</p>
31	IDP_PDAP_EN	<p>PDAP Enable.</p> <p>0 = Disconnects all PDAP inputs (data/control) from use as parallel input channel. 1 = Connects all PDAP inputs (data/control) from use as parallel input channel. IDP channel 0 cannot be used as a serial input port with this setting enabled.</p>

Status Register (DAI_STAT0)

The IDP DMA status register shown in [Figure A-57](#) and described in [Table A-36](#) reflects the status of the standard and ping-pong DMA channels.

Peripherals Routed Through the DAI

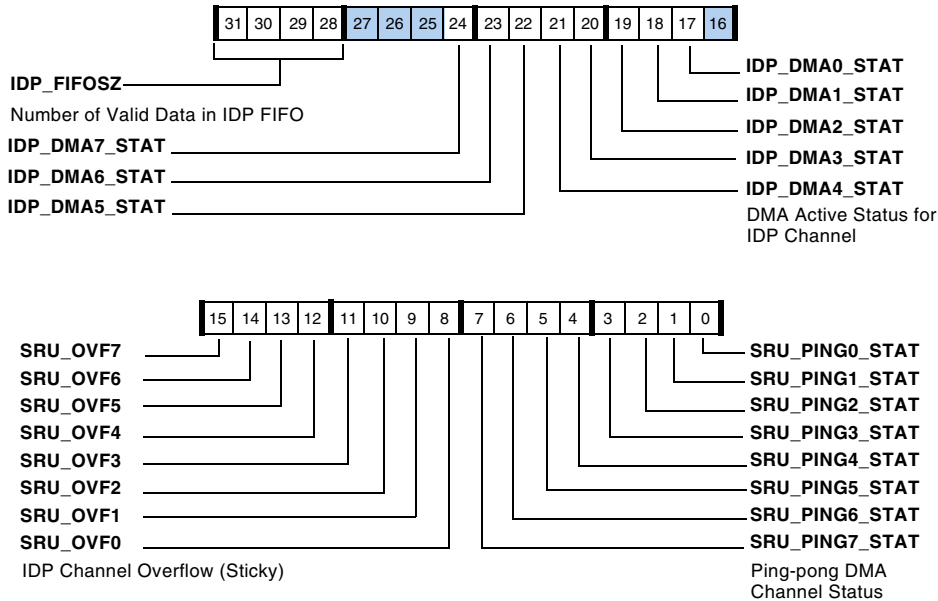

Figure A-57. DAI_STAT0 Register

Table A-36. DAI_STAT0 Register Bit Descriptions (RO)

Bit	Name	Description
7–0	SRU_PINGx_STAT	Ping-pong DMA Channel Status. Indicates the status of ping-pong DMA in each respective channel (channel 7–0). 0 = Ping DMA is active 1 = Pong DMA is active
15–8	SRU_OVFx	Sticky Overflow Channel Status. Provides overflow status information for each channel (bit 8 for channel 0 through bit 15 for channel 7). 0 = SRU input no overflow 1 = SRU input overflow has occurred
16	Reserved	

Table A-36. DAI_STAT0 Register Bit Descriptions (RO) (Cont'd)

Bit	Name	Description
24–17	IDP_DMAx_STAT	Input Data Port DMA Channel Status. These bits reflect the state of all eight DMA channels. These bits are set once IDP_DMA_EN is set and remain set until the last data of that channel is transferred. Even if IDP_DMA_EN is set (=1), this bit goes low once the required number of data transfers occur. Note if DMA through some channel is not intended, this bit goes high. 0 = DMA is not active 1 = DMA is active
27–25	Reserved	
31–28	IDP_FIFOSZ	IDP FIFO Size. Indicates Number of samples in the IDP FIFO. 0000 = IDP FIFO empty 1000 = IDP FIFO full

Status Debug Register 1 (DAI_STAT1)

Since the core does allow writes to the IDP_FIFO, the DAI_STAT1 debug register stores the different read or writes indexes with a maximum of 8 entries each.

Table A-37. DAI_STAT1 Register Bit Descriptions (RO)

Bit	Name	Description
3–0	FIFO_WRI	Write Index Pointer. Reflects the write index status during core writes to the IDP_FIFO. 0000 = no write done 1000 = 8 writes done
7–4	FIFO_RDI	Read Index Pointer. Reflects the read index status during core reads from the IDP_FIFO. 0000 = no read done 1000 = 8 reads done
31–8	Reserved	

Sample Rate Converter Registers

The sample rate converter (SRC) is composed of five registers which are described in the following sections.

Control Registers (SRCCTLx)

The SRCCTLn control registers control the operating modes, filters, and data formats used in the sample rate converter. For n = 0, the register controls the SRC0 and SRC1 modules and for n = 1 it controls the SRC2 and SRC3 modules (x = 0, 2 and y = 1, 3). The bit settings for these registers are shown in [Figure A-58](#) and described in [Table A-38](#).

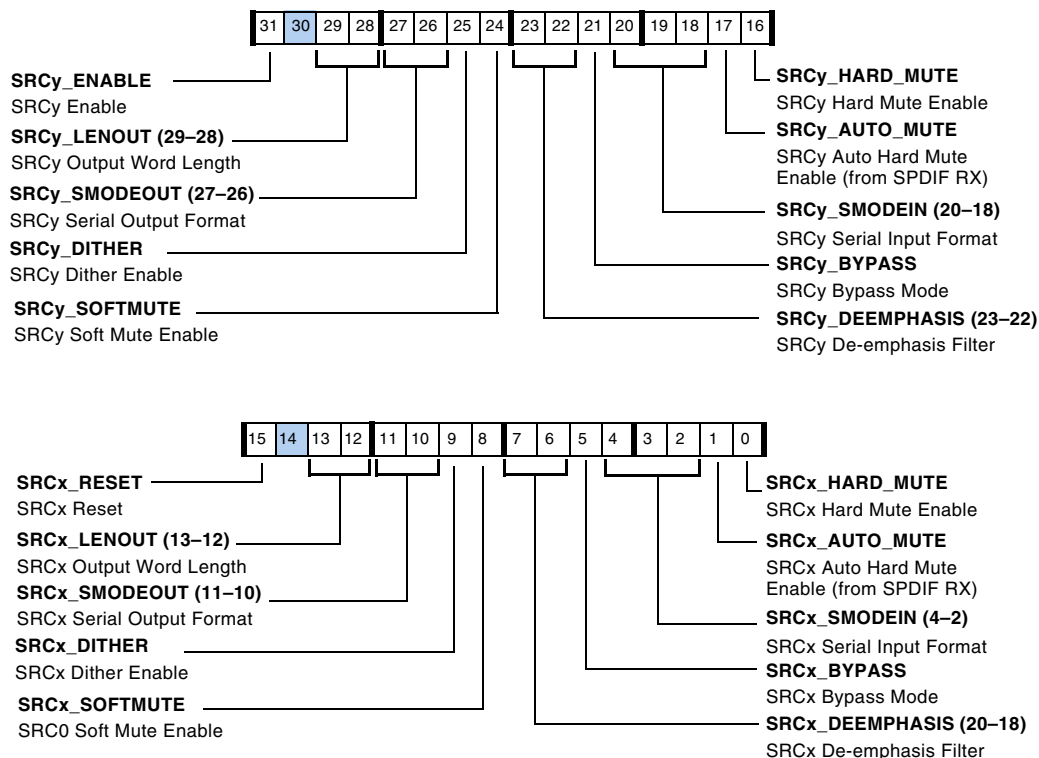

Figure A-58. SRCCTLx Register

Table A-38. SRCCTLx Register Bit Descriptions (RW)

Bit	Name	Description
0	SRCx_HARD_MUTE	Hard Mute. Hard mutes SRC 0, 2. 1 = Mute (default)
1	SRCx_AUTO_MUTE	Auto Hard Mute. Auto hard mutes SRC 0, 2 when non audio is asserted by the SPDIF receiver. 0 = No mute 1 = Mute (default)
2–4	SRCx_SMODEIN	Serial Input Format. Selects the serial input format for SRC 0, 2 as follows: 000 = Left-justified (default) 001 = I ² S 010 = TDM 100 = 24-bit right-justified 101 = 20-bit right-justified 110 = 18-bit right-justified 111 = 16-bit right-justified
5	SRCx_BYPASS	Bypass SRCx. Output of SRC 0, 2 is the same as the input.
6–7	SRCx_DEEMPHASIS	De-emphasis Filter Select. Used to de-emphasize audio data that has been emphasized. The type of de-emphasis filter is selected by the SRCx_DEEMPHASIS bits and is based on the input sample rate (SRCx_FS_IP_I signal) as follows: enables de-emphasis on incoming audio data for SRC 0, 2. 00 = No de-emphasis 01 = 32 kHz 10 = 44.1 kHz 11 = 48 kHz
8	SRCx_SOFTMUTE	Soft Mute. Enables soft mute on SRC 0, 2. 0 = No mute 1 = Mute (default)
9	SRCx_DITHER	Dither Select. Enables dithering on SRC 0, 2 when a word length less than 24 bits is selected. 0 = Dithering is enabled 1 = Dithering is disabled

Peripherals Routed Through the DAI

Table A-38. SRCCTLx Register Bit Descriptions (RW) (Cont'd)

Bit	Name	Description
10–11	SRCx_SMODEOUT	Serial Output Format. Selects the serial output format on SRC 0, 2 as follows: 00 = Left-justified (default) 01 = I ² S 10 = TDM mode 11 = Right-justified. The right-justified serial data out mode assumes 64 SCLK cycles per frame, divided evenly for left and right. For the other modes these 8 LSBs contain zeros.
12–13	SRCx_LENOUT	Output Word Length Select. Selects the serial output word length on SRC 0, 2 as follows: 00 = 24 bits 01 = 20 bits 10 = 18 bits 11 = 16 bits Any word length less than 24 bits has dither added to the unused LSBs if SRCx_DITHER is enabled (= 1).
14	Reserved	
15	SRCx_ENABLE	SRC0 Enable. Enables SRC 0, 2. When (set = 1), or when the sample rate (frame sync) between the input and output changes, the SRC begins its initialization routine where; 1) MUTE_OUT is asserted, 2) soft mute control counter for input samples is set to maximum attenuation (–144 dB). Note that SRC power-up completion is finished by clearing the SRCx_MUTE-OUT bit in SRCRATx register. Writes to the SRCCTLx register should be at least one cycle before setting the SRCx_ENABLE. When setting and clearing this bit, it should be held low for a minimum of 5 PCLK cycles. Programs should disable the SRC when changing modes. 0 = Disabled 1 = Enabled
16	SRCy_HARD_MUTE	Hard Mute. Hard mutes SRC 1, 3. 1 = Mute (default)

Table A-38. SRCCTLx Register Bit Descriptions (RW) (Cont'd)

Bit	Name	Description
17	SRCy_AUTO_MUTE	Auto Hard Mute. Auto hard mutes SRC 1, 3 when non audio is asserted by the SPDIF receiver. 0 = No mute 1 = Mute (default)
18–20	SRCy_SMODEIN	Serial Input Format. Selects the serial input format for SRC 1, 3 as follows: 000 = Left-justified (default) 001 = I ² S 010 = TDM 100 = 24-bit right-justified 101 = 20-bit right-justified 110 = 18-bit right-justified 111 = 16-bit right-justified
21	SRCy_BYPASS	Bypass Mode Enable. Output of SRC 1, 3 is the same as input.
22–23	SRCy_DEEMPHASIS	De-emphasis Filter Select. Enables de-emphasis on incoming audio data for SRC 1, 3. 00 = No de-emphasis 01 = 32 kHz 10 = 44.1 kHz 11 = 48 kHz
24	SRCy_SOFTMUTE	Soft Mute. Enables soft mute on SRC 1, 3. 0 = No mute 1 = Mute (default)
25	SRCy_DITHER	Dither Select. Disables dithering on SRC 1, 3 when a word length less than 24 bits is selected. 0 = Dithering is disabled (default) 1 = Dithering is enabled
26–27	SRCy_SMODEOUT	Serial Output Format. Selects the serial output format for SRC 1, 3 as follows. 00 = Left-justified (default) 01 = I ² S 10 = TDM mode 11 = Right-justified

Peripherals Routed Through the DAI

Table A-38. SRCCTLx Register Bit Descriptions (RW) (Cont'd)

Bit	Name	Description
28–29	SRCy_LENOUT	Output Word Length Select. Selects the serial output word length for SRC 1, 3 as follows: 00 = 24 bits 01 = 20 bits 10 = 18 bits 11 = 16 bits Any word length less than 24 bits has dither added to the unused LSBs if SRCx_DITHER is enabled (= 0).
30	Reserved	
31	SRCy_ENABLE	SRC Enable. Enables SRC 1, 3. When (set = 1), or when the sample rate (frame sync) between the input and output changes, the SRC begins its initialization routine where; 1) MUTE_OUT is asserted, 2) soft mute control counter for input samples is set to maximum attenuation (–144 dB). Note that SRC power-up completion is finished by clearing the SRCx_MUTE_OUT bit in SRCRATx register. Writes to the SRCCTLx register should be at least one cycle before setting the SRCx_ENABLE. When setting and clearing this bit, it should be held low for a minimum of 5 PCLK cycles. Programs should disable the SRC when changing modes.

Mute Register (SRCMUTE)

This register connects an SRCx mute input and output when the SRC0_MUTE_ENx bit is cleared (=0). This allows SRCx to automatically mute input while the SRC is initializing (0 = automatic muting and 1 = manual muting). Bit 0 controls SRC0, bit 1 controls SRC1, bit 2 controls SRC2, and bit 3 controls SRC3.

Table A-39. SRCMUTE Register Bit Descriptions (RW)

Bit	Name	Description
0	SRC0_MUTE_EN	SRC 0 Automatic Muting Enable. 0 = Connect SRC0 mute output to mute input 1 = Do not connect SRC0 mute output to mute input
1	SRC1_MUTE_EN	SRC 1 Automatic Muting Enable. 0 = Connect SRC1 mute output to mute input 1 = Do not connect SRC1 mute output to mute input
2	SRC2_MUTE_EN	SRC 2 Automatic Muting Enable. 0 = Connect SRC2 mute output to mute input 1 = Do not connect SRC2 mute output to mute input
3	SRC3_MUTE_EN	SRC 3 Automatic Muting Enable. 0 = Connect SRC3 mute output to mute input 1 = Do not connect SRC3 mute output to mute input

Ratio Registers (SRCRATx)

These registers report the mute and I/O sample ratio as follows: the SRCRAT0 register reports for SRC0 and SRC1 and the SRCRAT1 register reports the mute and I/O sample ratio for SRC2 and SRC3. The registers are shown in [Figure A-59](#) and [Figure A-60](#) and described in [Table A-40](#).

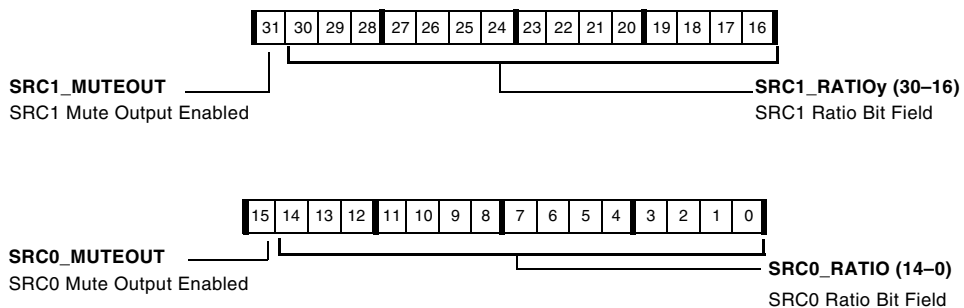

Figure A-59. SRCRAT0 Register

Peripherals Routed Through the DAI

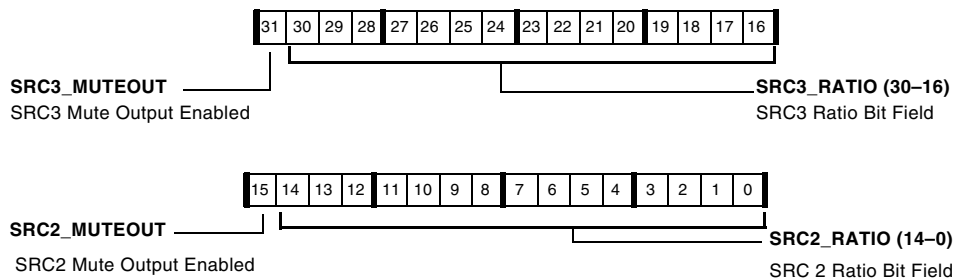

Figure A-60. SRCRAT1 Register

Table A-40. SRCRATx Register Bit Descriptions (RO)

Bit	Name	Description
14–0	SRCx_RATIOx	Sampling Ratio of Frame Syncs. These bits can be read to find the ratio of output to input sampling frequency ($SRCx_FS_OP_I/SRCx_FS_IP_I$). This ratio is reported in 4.11 (integer.fraction) format where the 15-bit value of the normal binary number is comprised of 4 bits for the integer and 11 bits for the fraction.
15	SRCx_MUTEOUTx	Mute Out Signal Status. The SRCx_MUTEOUT bits report the status of the MUTE_OUT signal. 0 = MUTE_OUT signal de-asserted 1 = MUTE_OUT signal asserted (default) Once the SRCx_MUTEOUT bit is cleared then the ratio can be read. When the SRCx_ENABLE bit is set or there is a change in the sample ratio, the MUTE_OUT signal is asserted. The MUTE_OUT signal remains asserted until the digital servo loop's internal fast settling mode is complete. When the digital servo loop has switched to slow settling mode, the MUTE_OUT signal is de-asserted.
30–16	SRCx_RATIOy	Sampling Ratio of Frame Syncs. See bits 14–0
31	SRCx_MUTEOUTy	Mute Status. See bit 15

Precision Clock Generator Registers

The precision clock generator (PCG) consists of four identical units. Each of these units (A, B, C, and D) generates one clock (CLKA_0, CLKB_0, CLKC_0 or CLKD_0) and one frame sync (FSA_0, FSB_0, FSC_0 or FSD_0) output.

Control Registers (PCG_CTLxy)

Two control registers (y=0, 1) operate for each unit. The control registers enable clocks, frame syncs, and select divisors for each unit. These registers are shown in [Figure A-61](#) and [Figure A-62](#) and described in [Table A-41](#) and [Table A-42](#). Note the different units (x = A, B, C, D) any clock unit can be chosen.

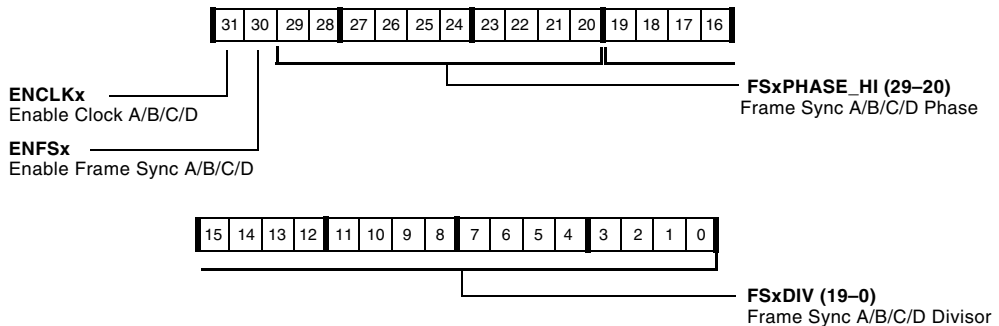

Figure A-61. PCG_CTLx0 Registers

Peripherals Routed Through the DAI

Table A-41. PCG_CTLx0 Register Bit Descriptions (RW)

Bit	Name	Description
19–0	FSxDIV	Divisor for Frame Sync A/B/C/D. This 20-bit field frame sync divider is multiplexed: FSxDIV >1 PCGx is in normal mode FSxDIV =0, 1 PCGx is in bypass mode Fore more information on bypass mode refer to the STROBEx and INVFSx bits of PCG_PWx register.
29–20	FSxPHASE_HI	Phase for Frame Sync A/B/C/D. This field represents the upper half of the 20-bit value for the channel A/B/C/D frame sync phase. See also FSXPHASE_LO (Bits 29-20) in Table A-42 .
30	ENFSx	Enable Frame Sync A/B/C/D. 0 = Specified frame sync generation disabled 1 = Specified frame sync generation enabled
31	ENCLKx	Enable Clock A/B/C/D. 0 = Specified clock generation disabled 1 = Specified clock generation enabled

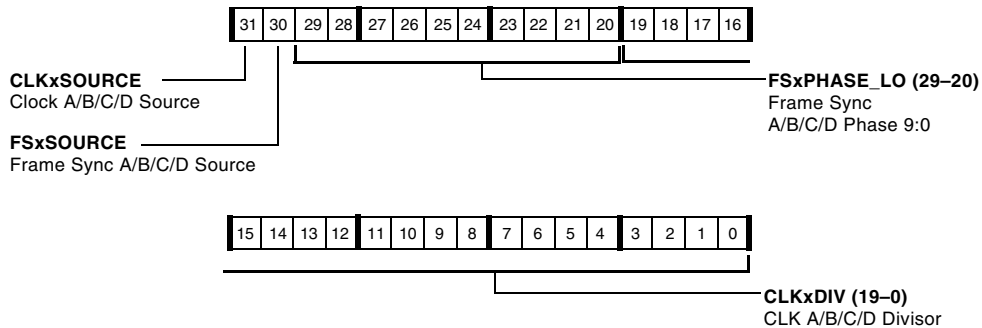

Figure A-62. PCG_CTLx1 Register

Table A-42. PCG_CTLx1 Register Bit Descriptions (RW)

Bit	Name	Description
19–0	CLKxDIV	Divisor for Serial Clock A/B/C/D. This 20-bit field serial clock divider performs: CLKxDIV >1 PCGx performs clock division CLKxDIV = 0, 1 PCGx performs clock bypass
29–20	FSxPHASE_LO	Phase for Frame Sync A/B/C/D. This field represents the lower half of the 20-bit value for the channel A/B/C/D frame sync phase. See also FSX-PHASE_HI (Bits 29-20) in PCG_CTLx1 described on page A-112 .
30	FSxSOURCE	Frame Sync Source. Master clock source for frame sync A/B/C/D. 0 = CLKIN pin selected for specified frame sync 1 = PCG_EXTX_I selected for specified frame sync This frame sync period is also a reference for the strobe period in one shot mode.
31	CLKxSOURCE	Clock Source. Master clock source for clock A/B/C/D. 0 = CLKIN pin selected for specified clock 1 = PCG_EXTx_I selected for specified clock The CLKxSOURCE bit specifies the input source for the clock of the respective units (A, B, C, and D). When this bit is cleared (= 0), the input is sourced from the external oscillator/crystal, as shown in Figure 11-1 on page 11-6 . When set (= 1), the input is sourced from DAI. Note the CLKxSOURCE bit is overridden if CLKx_SOURCE_IOP bit in the PCG_SYNCx register is set. If the CLKx_SOURCE_IOP bit is set, the input is sourced from the peripheral clock (PCLK).

Pulse Width Registers (PCG_PWx)

Pulse width is the number of input clock periods for which the frame sync output is HIGH. Pulse width should be less than the divisor of the frame sync. The pulse width control registers are shown in [Figure A-63](#) and [Figure A-64](#) and described in [Table A-43](#) and [Table A-44](#). Note that where letters and slashes appear, for example A/B/C/D, any clock unit can be chosen.

Peripherals Routed Through the DAI

The pulse width control registers (PCG_PW_x) are multiplexed and their bit description is dependent on the operation mode.

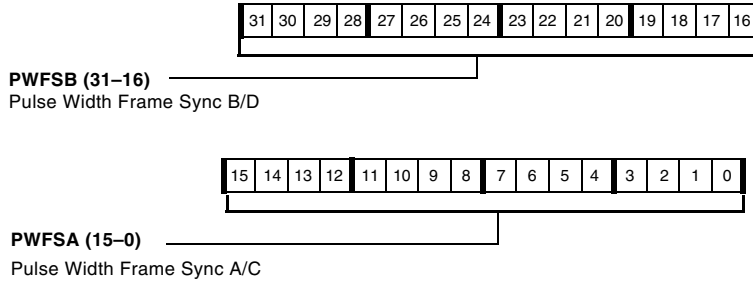

Figure A-63. PCG_PW_x Registers (Normal Mode)

Table A-43. PCG_PW_x Register Bit Descriptions (Normal Mode)

Bit	Name	Description
15-0	PWFSB	Pulse Width for Frame Sync A/C.
31-16	PWFSB	Pulse Width for Frame Sync B/D.

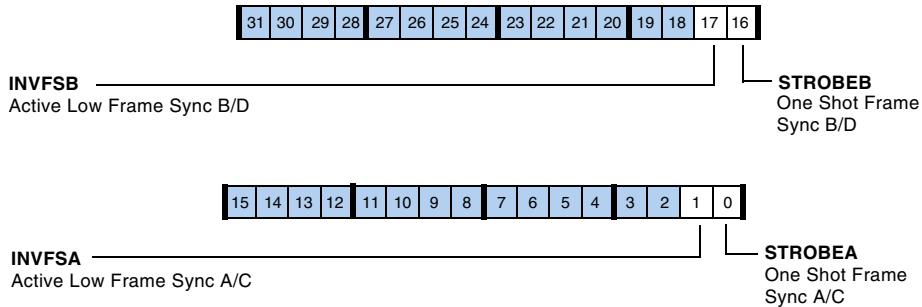

Figure A-64. PCG_PW_x Registers (Bypass Mode)

Table A-44. PCG_PW_x Register Bit Descriptions (Bypass Mode)

Bit	Name	Description
0	STROBE _x	Bypass/One Shot Input A/C. Frame sync output is bypassed from FS _x input or a pulse with duration equal to one period of the MISCA2_I signal (PCG A) MISCA4_I signal (PCG C) repeating at the beginning of every frame. 0 = Bypass mode 1 = One shot mode If the STROBEA/B/C/D bits are cleared, then the input is directly passed to the frame sync output, either not inverted or inverted, depending on the INVFS _A , INVFS _B , INVFS _C and INVFS _D bits of the PCG_PW and PCG_PW2 registers.
1	INVFS _x	Bypass/One Shot Inversion A/C. The Frame sync input signal from STROBE A/C bit is inverted. 0 = Active high frame sync 1 = Active low frame sync
15–2	Reserved (In bypass mode, bits 15-2 are ignored.)	
16	STROBE _x	Bypass/One Shot Input B/D. Frame sync output is bypassed from FS _x input or a pulse with duration equal to one period of the MISCA3_I signal (PCG B) MISCA5_I signal (PCG D) repeating at the beginning of every frame. 0 = Bypass mode 1 = One shot mode
17	INVFS _x	Bypass/One Shot Inversion A/C. The Frame sync input signal from STROBE _B /D bit is inverted. 0 = Active high frame sync 1 = Active low frame sync
31–18	Reserved (In bypass mode, bits 31–18 are ignored.)	

Frame Synchronization Registers (PCG_SYNC_x)

These registers, shown in [Figure A-65](#), and [Figure A-66](#) and described in [Table A-45](#) and [Table A-46](#), allow programs to synchronize the clock frame syncs units with external frame syncs.

Peripherals Routed Through the DAI

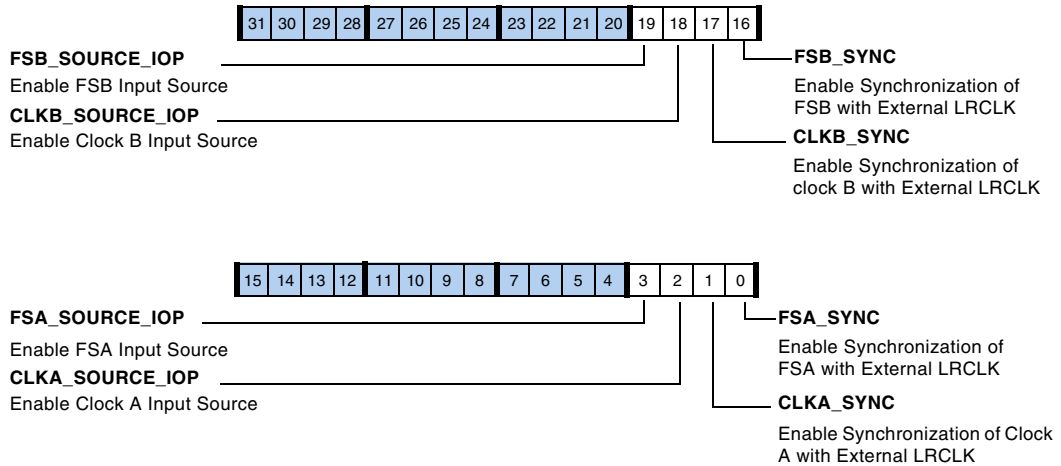

Figure A-65. PCG_SYNC1 Register

Table A-45. PCG_SYNC1 Register Bit Descriptions (RW)

Bit	Name	Description
0	FSA_SYNC	Enable Synchronization of Frame Sync A With External Frame Sync. 0 = Frame sync disabled 1 = Frame sync enabled
1	CLKA_SYNC	Enable Synchronization of Clock A With External Frame Sync. 0 = Clock disabled 1 = Clock enabled
2	CLKA_SOURCE_IOP	Enable Clock A Input Source. 0 = Output selected by CLKASOURCE bit 1 = PCLK selected for clock A. Note the CLKxSOURCE bits (PCG_CTLx1 register) are overridden if CLKx_SOURCE_IOP bit is set.
3	FSA_SOURCE_IOP	Enable Frame Sync A Input Source. 0 = Output selected by FSASOURCE bit 1 = PCLK selected for frame sync A. Note the FSxSOURCE bits (PCG_CTLx1 register) are overridden if FSx_SOURCE_IOP bit is set.

Table A-45. PCG_SYNC1 Register Bit Descriptions (RW) (Cont'd)

Bit	Name	Description
16	FSB_SYNC	Enable Synchronization of Frame Sync B With External Frame Sync. 0 = Frame sync disabled 1 = Frame sync enabled
17	CLKB_SYNC	Enable Synchronization of Clock B With External Frame Sync. 0 = Clock disabled 1 = Clock enabled
18	CLKB_SOURCE_IOP	Enable Clock B Input Source. 0 = Output selected by CLKBSOURCE bit 1 = PCLK selected for clock B. Note the CLKxSOURCE bits (PCG_CTLx1 register) are overridden if CLKx_SOURCE_IOP bit is set.
19	FSB_SOURCE_IOP	Enable Frame Sync B Input Source. 0 = Output selected by FSBSOURCE bit 1 = PCLK selected for frame sync B. Note the FSxSOURCE bits (PCG_CTLx1 register) are overridden if FSx_SOURCE_IOP bit is set.

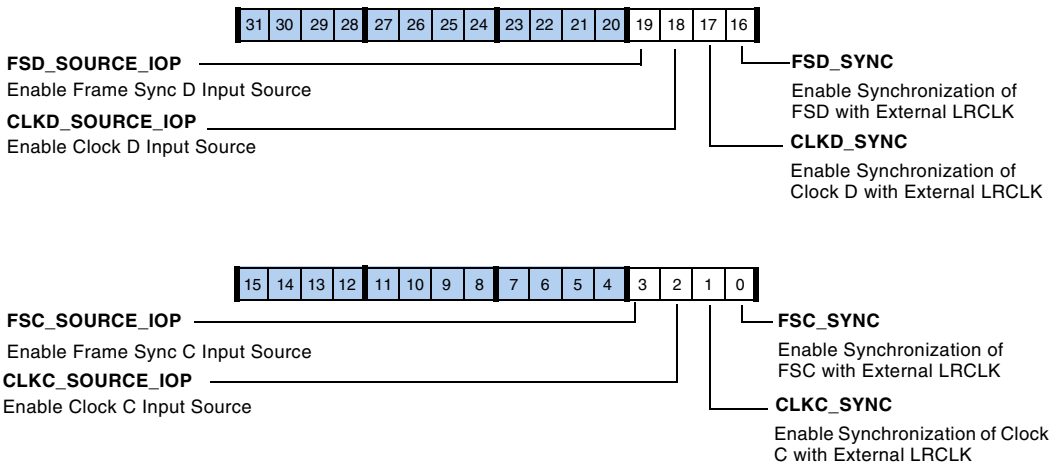

Figure A-66. PCG_SYNC2 Register

Peripherals Routed Through the DAI

Table A-46. PCG_SYNC2 Register Bit Descriptions (RW)

Bit	Name	Description
0	FSC_SYNC	Enable Synchronization of Frame Sync C With External Frame Sync. 0 = Frame sync disabled 1 = Frame sync enabled
1	CLKC_SYNC	Enable Synchronization of Clock C With External Frame Sync. 0 = Clock disabled 1 = Clock enabled
2	CLKC_SOURCE_IOP	Enable Clock C Input Source. 0 = Output selected by CLKCSOURCE bit 1 = PCLK selected for clock C. Note the CLKxSOURCE bits (PCG_CTLx1 register) are overridden if CLKx_SOURCE_IOP bit is set.
3	FSC_SOURCE_IOP	Enable Frame Sync C Input Source. 0 = Output selected by FSCSOURCE bit 1 = PCLK selected for frame sync C. Note the FSxSOURCE bits (PCG_CTLx1 register) are overridden if FSx_SOURCE_IOP bit is set.
16	FSD_SYNC	Enable Synchronization of Frame Sync D With External Frame Sync. 0 = Frame sync disabled 1 = Frame sync enabled
17	CLKD_SYNC	Enable Synchronization of Clock D With External Frame Sync. 0 = Clock disabled 1 = Clock enabled
18	CLKD_SOURCE_IOP	Enable Clock D Input Source. 0 = Output selected by CLKDSOURCE bit 1 = PCLK selected for clock D.
19	FSD_SOURCE_IOP	Enable Frame Sync D Input Source. 0 = Output selected by FSDSOURCE bit 1 = PCLK selected for frame sync D.

Sony/Philips Digital Interface Registers

The following sections describe the registers that are used to configure, enable, and report status information for the S/PDIF transceiver.

Transmitter Registers

The following sections describe the transmitter registers.

Transmit Control Register (DITCTL)

This 32-bit register's bits are shown in [Figure A-67](#) and described in [Table A-47](#).

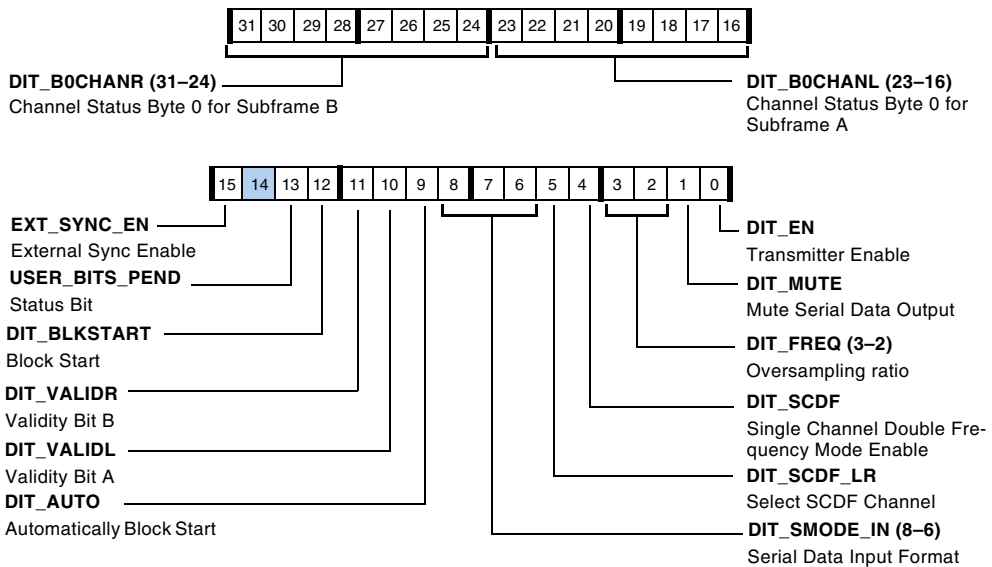

Figure A-67. DITCTL Register

Peripherals Routed Through the DAI

Table A-47. DITCTL Register Bit Descriptions (RW)

Bit	Name	Description
0	DIT_EN	Transmitter Enable. Enables the transmitter and resets the control registers to their defaults. 0 = Transmitter disabled 1 = Transmitter enabled
1	DIT_MUTE	Mute. Mutes the serial data output.
3–2	DIT_FREQ	Frequency Multiplier. Sets the over sampling ratio to the following: 00 = 256 x frame sync 01 = 384 x frame sync
4	DIT_SCDF	Single-channel, Double-frequency Mode Enable. 0 = 2 channel mode 1 = SCDF mode
5	DIT_SCDF_LR	Select Single-channel, Double-frequency Mode. 0 = Left channel 1 = Right channel
8–6	DIT_SMODEIN	Serial Data Input Format. Selects the input format as follows: 000 = Left-justified 001 = I ² S 010 = reserved 011 = reserved 100 = Right-justified, 24-bits 101 = Right-justified, 20-bits 110 = Right-justified, 18-bits 111 = Right-justified, 16-bits
9	DIT_AUTO	Automatically Generate Block Start. Automatically generate block start. When enabled, the transmitter is in standalone mode where it inserts block start, channel status, and validity bits on its own. If the channel status or validity buffer needs to be enabled (after the SRU programming is complete), first write to the buffers with the required data and then enable the buffers by setting the DIT_AUTO bit. 0 = Manually start block transfer according to input stream status bits 1 = Automatically start block transfer.
10	DIT_VALIDL	Validity Bit A. Use with channel status buffer.

Table A-47. DITCTL Register Bit Descriptions (RW) (Cont'd)

Bit	Name	Description
11	DIT_VALIDR	Validity Bit B. Use with channel status buffer.
12 (RO)	DIT_BLKSTART	Block Start. Status bit that indicates block start (when bit 9, DIT_AUTO = 1). 0 = Current word is not block start 1 = Current word is block start
13 (RO)	USER_BITS_PEND	User Bits Pending. This bit is set if the update of the internal buffer from the DITUSRBITA/Bx registers has not completed yet.
14	Reserved	
15	EXT_SYNC_EN	External Sync Enable. When set (Regardless of bit 9) the internal frame counter is set to zero at an internal LRCLK rising edge followed by an DIT_EXTSYNC_I rising edge.
23–16	DIT_B0CHANL	Channel Status Byte 0 for Subframe A.
31–24	DIT_B0CHANR	Channel Status Byte 0 for Subframe B.

Transmit Status Bit Registers for Subframe A/B (DITCHANAx/Bx)

These registers provide status information for transmitter subframe A and B. The first five bytes of the channel status may be written all at once to the control registers for both A and B channels. As the data is serialized and transmitted, the appropriate bit is inserted into the channel status area of the 192-word frame. Note that these registers are used in standalone mode only.

There are six channel status registers associated with subframe A (left channel) and six user bits buffer registers associated with subframe B (right channel). Since a block owns 2 x 192 frames, 24 bytes per frame are required for storage. Note that status byte 0 is available in the DITCTL register. These registers are listed with their locations in [Table A-48](#) and [Table A-49](#).

Peripherals Routed Through the DAI

Table A-48. DITCHANAx Registers (RW)

Register	Bits 7–0	Bits 15–8	Bits 23–16	Bits 31–24
DITCTL			BYTE0	
DITCHANA0	BYTE1	BYTE2	BYTE3	BYTE4
DITCHANA1	BYTE5	BYTE6	BYTE7	BYTE8
DITCHANA2	BYTE9	BYTE10	BYTE11	BYTE12
DITCHANA3	BYTE13	BYTE14	BYTE15	BYTE16
DITCHANA4	BYTE17	BYTE18	BYTE19	BYTE20
DITCHANA5	BYTE21	BYTE22	BYTE23	Reserved

Table A-49. DITCHANBx Registers (RW)

Register	Bits 7–0	Bits 15–8	Bits 23–16	Bits 31–24
DITCTL				BYTE0
DITCHANB0	BYTE1	BYTE2	BYTE3	BYTE4
DITCHANB1	BYTE5	BYTE6	BYTE7	BYTE8
DITCHANB2	BYTE9	BYTE10	BYTE11	BYTE12
DITCHANB3	BYTE13	BYTE14	BYTE15	BYTE16
DITCHANB4	BYTE17	BYTE18	BYTE19	BYTE20
DITCHANB5	BYTE21	BYTE22	BYTE23	Reserved

Transmit User Bits Buffer Registers for Subframe A/B Registers (DITUSRBITAx/Bx)

Once programmed, these registers are used only for the next block of data. This allows programs to change the user bit information with every block of data. After writing to the appropriate registers to change the user bits for the next block, DITUSRBITAx and DITUSRBITBx must be written to enable the use of these bits. Note these registers are used in standalone mode only.

There are six user bits buffer registers associated with subframe A (left channel) and six user bits buffer registers associated with subframe B (right channel). These registers are listed with their locations in [Table A-50](#) and [Table A-51](#).

Table A-50. DITUSRBITAx Registers (RW)

Register	Bits 7–0	Bits 15–8	Bits 23–16	Bits 31–24
DITUSRBITA0	BYTE0	BYTE1	BYTE2	BYTE3
DITUSRBITA1	BYTE4	BYTE5	BYTE6	BYTE7
DITUSRBITA2	BYTE8	BYTE9	BYTE10	BYTE11
DITUSRBITA3	BYTE12	BYTE13	BYTE14	BYTE15
DITUSRBITA4	BYTE16	BYTE17	BYTE18	BYTE19
DITUSRBITA5	BYTE20	BYTE21	BYTE22	BYTE23

Table A-51. DITUSRBITBx Registers (RW)

Register	Bits 7–0	Bits 15–8	Bits 23–16	Bits 31–24
DITUSRBITB0	BYTE0	BYTE1	BYTE2	BYTE3
DITUSRBITB1	BYTE4	BYTE5	BYTE6	BYTE7
DITUSRBITB2	BYTE8	BYTE9	BYTE10	BYTE11
DITUSRBITB3	BYTE12	BYTE13	BYTE14	BYTE15
DITUSRBITB4	BYTE16	BYTE17	BYTE18	BYTE19
DITUSRBITB5	BYTE20	BYTE21	BYTE22	BYTE23

User Bit Update Register (DITUSRUPD)

This register is a 1-bit wide register (WO). After writing to the user bits registers (DITUSRBITAx and DITUSRBITBx), a value of 0x1 must be written into DITUSRUPD register to enable the use of these bits in the next block of transfer.

Peripherals Routed Through the DAI

Receiver Registers

The following sections describe the receiver registers.

Receive Control Register (DIRCTL)

This 32-bit register, described in [Table A-52](#) is used to set up error control and single-channel double-frequency mode.

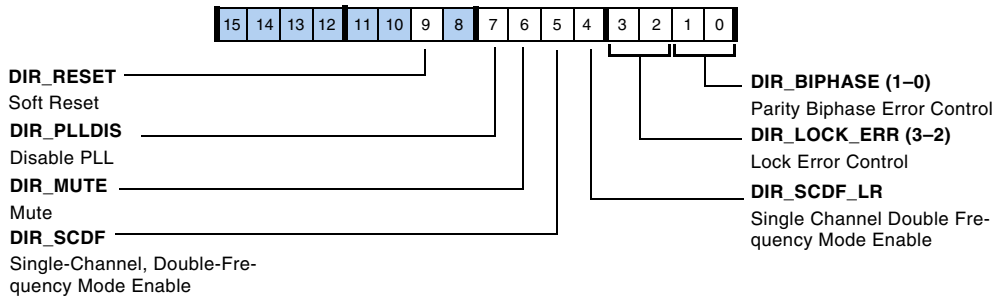

Figure A-68. DIRCTL Register

Table A-52. DIRCTL Register Bit Descriptions (RW)

Bit	Name	Description
1–0	DIR_BIPHASE	Parity Biphase Error Control. When a parity or biphase error occurs, the audio data is handled as: 00 = No action taken 01 = Hold last valid sample 10 = Replace invalid sample with zeros 11 = Reserved
3–2	DIR_LOCK_ERR	Lock Error Control. When the DIR_LOCK bit in the DIRSTAT register is de-asserted, the PLL has become unlocked and the audio data is handled according to these bit settings. 00 = No action taken 01 = Hold last valid sample 10 = Send zeros after the last valid sample 11 = Soft mute of the last valid audio is performed (as if NOSTREAM is asserted). This is valid only when linear PCM audio data is in the stream. When non-linear audio data is in the stream, this mode defaults to the case of DIR_LOCK_ERR1–0 bits = 10.
4	DIR_SCDF_LR	Single-channel, Double-frequency Channel Select. 0 = Left channel 1 = Right channel
5	DIR_SCDF	Single-channel, Double-frequency Mode Enable. 0 = 2 channel mode enabled 1 = SCDF mode
6	DIR_MUTE	Mute. 0 = Mute disabled 1 = Mute serial data outputs, maintaining clocks (digital black)
7	DIR_PLLDIS	Disable Digital PLL. Determines clock input for S/PDIF receiver. 0 = Use derived clock from the digital PLL 1 = Use clock input from external PLL and disable digital PLL
8	Reserved	

Peripherals Routed Through the DAI

Table A-52. DIRCTL Register Bit Descriptions (RW) (Cont'd)

Bit	Name	Description
9	DIR_RESET	Reset S/PDIF Receiver. By default, the S/PDIF receiver is always enabled. If this bit is set, the S/PDIF receiver and digital PLL are disabled.
31–10	Reserved	

Receive Status Register (DIRSTAT)

This register is used to store the status and error bits. This register also contains the lower byte of the 40-bit channel status information. The bit settings for these registers are shown in [Figure A-69](#) and described in [Table A-53](#).

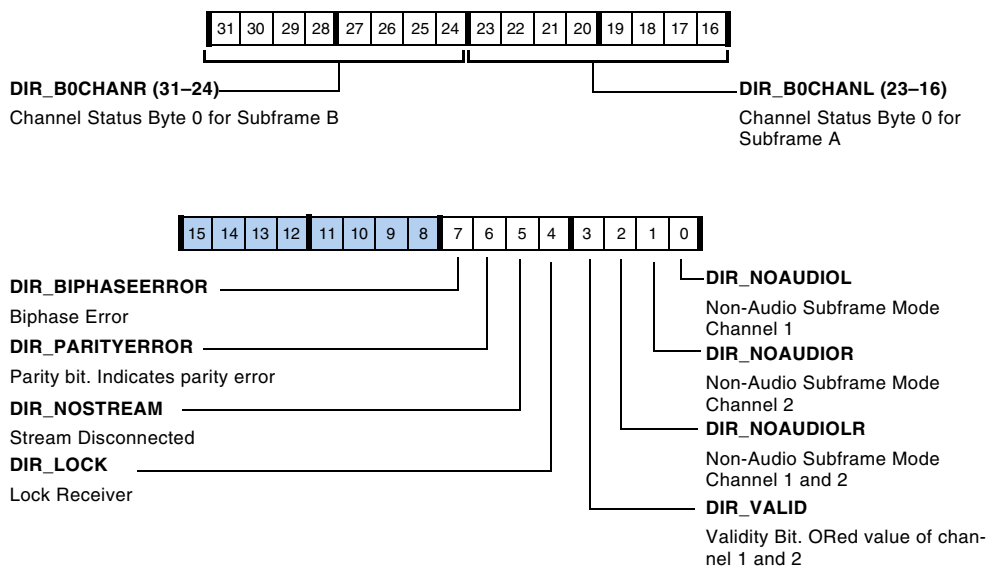

Figure A-69. DIRSTAT Register

Table A-53. DIRSTAT Register Bit Descriptions (RO)

Bit	Name	Description
0	DIR_NOAUDIOL	Non-Audio Subframe Mode Channel 1. Based on SMPTE 337M. 0 = Audio subframe mode 1 = Non-audio subframe mode, channel 1
1	DIR_NOAUDIOR	Non-Audio Subframe Mode Channel 2. Based on SMPTE 337M. 0 = Audio subframe mode 1 = Non-audio subframe mode, channel 2
2	DIR_NOAUDIOLR	Non-Audio Frame Mode Channel 1 and 2. Based on SMPTE 337M. 0 = Audio frame mode 1 = Non-audio frame mode
3 (ROC)	DIR_VALID	Validity Bit. ORed bits of channel 1 and 2. 0 = Linear PCM data 1 = Non-linear audio data This bit can also trigger a DAI interrupt.
4 (ROC)	DIR_LOCK	Lock Receiver. When set (=1), the digital PLL of receiver is locked, the corresponding DIR_LOCK bit is set. This bit can be polled to detect the DIR_LOCK condition. After the receiver is locked, the other status bits in DIRSTAT and the channel status (DIRCHANL/R) registers can be read. Interrupts can be also used with some status bits. 0 = Receiver not locked 1 = Receiver locked This bit can also trigger a DAI interrupt.

Peripherals Routed Through the DAI

Table A-53. DIRSTAT Register Bit Descriptions (RO) (Cont'd)

Bit	Name	Description
5 (ROC)	DIR_NOSTREAM	<p>No Stream Error. Asserted when the AES3/SPDIF stream is disconnected. When this bit is asserted and the audio data in the stream is linear PCM, the receiver performs a soft mute of the last valid sample from the AES3/SPDIF stream. A soft mute consists of taking the last valid audio sample and slowly and linearly decrementing it to zero, over a period of 4096 frames. During this time, the PLL three-states the charge pump until the soft mute has been completed. If non-linear PCM audio data is in the AES3/SPDIF stream when the NOSTREAM bit is asserted, the receiver sends out zeros after the last valid sample.</p> <p>0 = Stream not disconnected 1 = Stream disconnected (default) This bit can also trigger a DAI interrupt.</p>
6 (ROC)	DIR_PARITYERROR	<p>Parity Bit. When cleared, (=0), indicates that the AES3/SPDIF stream was received with the correct parity, or even parity. When set (=1), indicates that an error has occurred, and the parity is odd.</p> <p>0 = No parity error 1 = Parity error This bit can also trigger a DAI interrupt.</p>
7 (ROC)	DIR_BIPHASEERROR	<p>Biphase Error. When set (=1), indicates that a biphase error has occurred and the data sampled from the biphase stream may not be correct.</p> <p>0 = No biphase error 1 = Biphase error This bit can also trigger a DAI interrupt.</p>
15–8	Reserved	
23–16	DIR_B0CHANL	<p>Channel Status Byte 0 for Subframe A. This bit can also trigger a DAI interrupt (emphasis or status change).</p>
31–24	DIR_B0CHANR	<p>Channel Status Byte 0 for Subframe B. This bit can also trigger a DAI interrupt (emphasis or status change).</p>

Receive Status Registers for Subframe A (DIRCHANL)

The S/PDIF receiver stores a maximum of 5 bytes (40-bit) status information. Note that status byte 0 is available in the DIRCTL register. This 32-bit register is described in [Table A-54](#).

Table A-54. DIRCHANL Register (RO)

Register	Bits 7–0	Bits 15–8	Bits 23–16	Bits 31–24
DIRSTAT			BYTE0	
DIRCHANL	BYTE1	BYTE2	BYTE3	BYTE4

Receive Status Registers for Subframe B (DIRCHANR)

The S/PDIF receiver stores a maximum of 5 bytes (40-bit) status information. Note that status byte 0 is available in the DIRCTL register. This 32-bit register is described in [Table A-55](#).

Table A-55. DIRCHANR Register (RO)

Register	Bits 7–0	Bits 15–8	Bits 23–16	Bits 31–24
DIRSTAT				BYTE0
DIRCHANR	BYTE1	BYTE2	BYTE3	BYTE4

DPI Signal Routing Unit Registers

The digital peripheral interface is comprised of a group of peripherals and the signal routing unit 2 (SRU2).

Miscellaneous Signal Routing Registers (SRU2_INPUTx, Group A)

Group A is used to route the 14 external pin signals to the inputs of the other peripherals. The MISCBx_0 outputs route to the interrupt latch bits or the pin buffer enable signals (PBEN).

All clock inputs that are not used should be set to logic low. The registers and input signals for group A are summarized in [Figure A-70](#) through [Figure A-74](#) and [Table A-56](#).

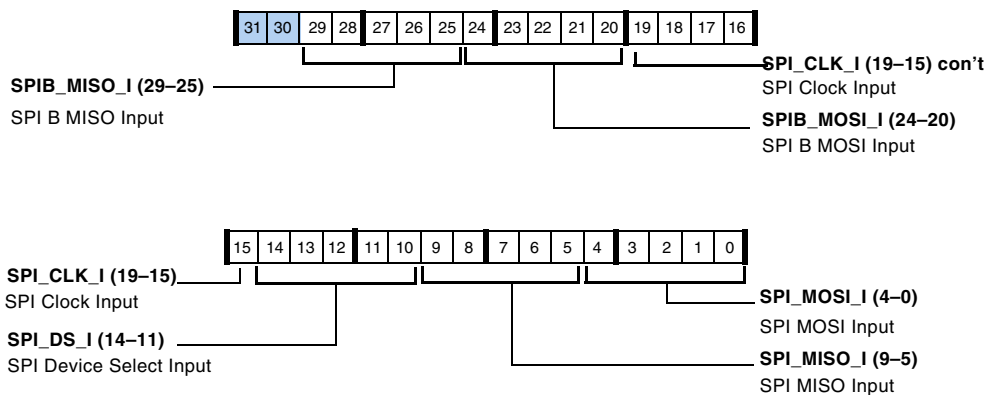

Figure A-70. SRU2_INPUT0 Register (RW)

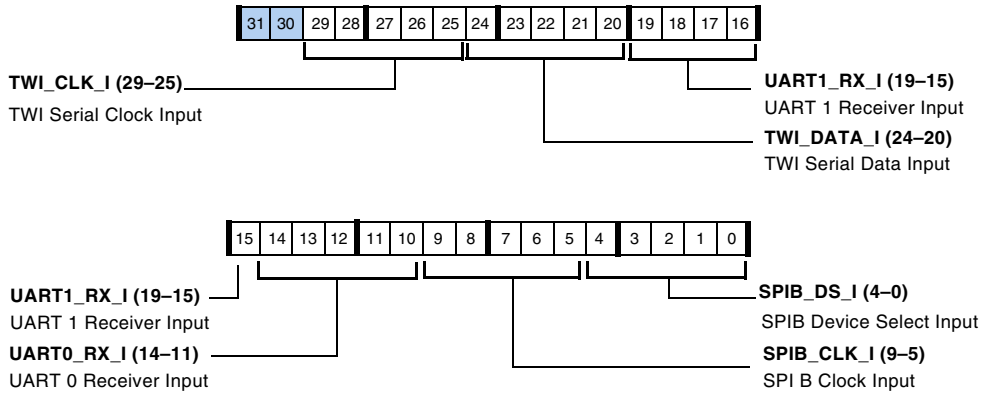

Figure A-71. SRU2_INPUT1 Register (RW)

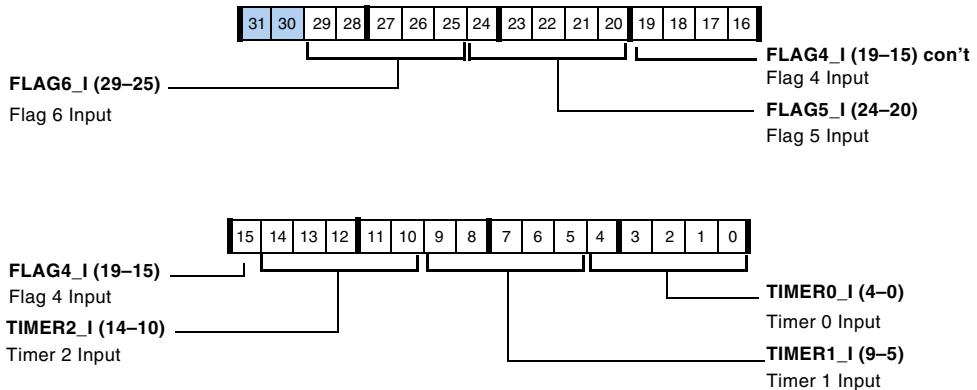

Figure A-72. SRU2_INPUT2 Register (RW)

DPI Signal Routing Unit Registers

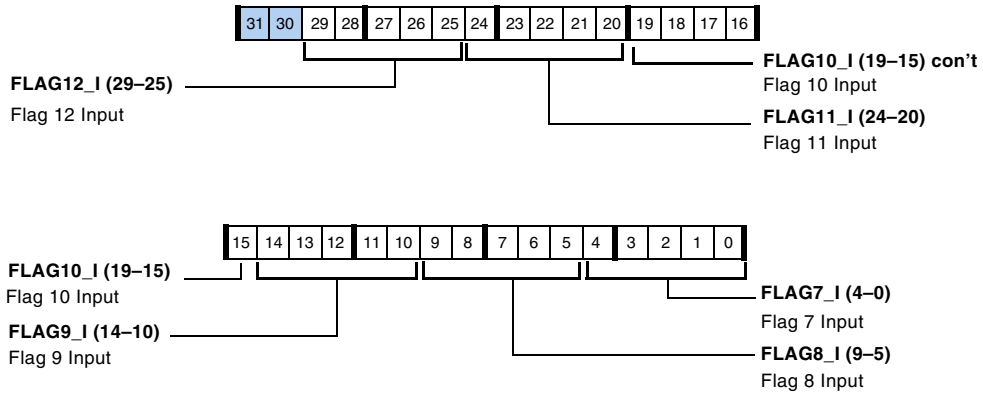

Figure A-73. SRU2_INPUT3 Register (RW)

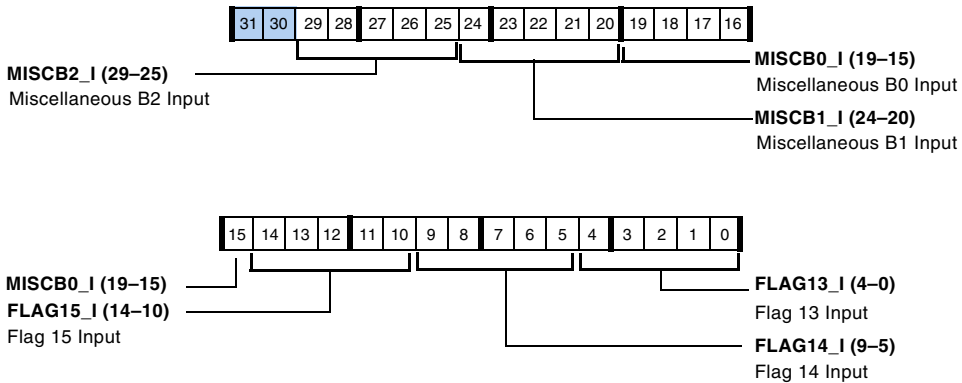

Figure A-74. SRU2_INPUT4 Register (RW)

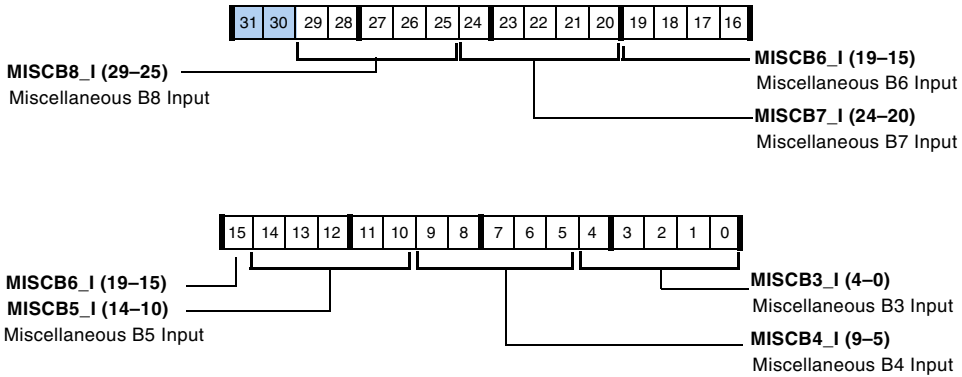

Figure A-75. SRU2_INPUT5 Register (RW)

Table A-56. Group A Connections

Selection Code	Signal	Description (Source selection)
00000 (0x0)	LOW	Logic level low (0)
00001 (0x1)	HIGH	Logic level high (1)
00010 (0x2)	DPI_P01_O	External pin 1
00011 (0x3)	DPI_P02_O	External pin 2
00100 (0x4)	DPI_P03_O	External pin 3
00101 (0x5)	DPI_P04_O	External pin 4
00110 (0x6)	DPI_P05_O	External pin 5
00111 (0x7)	DPI_P06_O	External pin 6
01000 (0x8)	DPI_P07_O	External pin 7
01001 (0x9)	DPI_P08_O	External pin 8
01010 (0xA)	DPI_P09_O	External pin 9
01011 (0xB)	DPI_P10_O	External pin 10
01100 (0xC)	DPI_P11_O	External pin 11
01101 (0xD)	DPI_P12_O	External pin 12
01110 (0xE)	DPI_P13_O	External pin 13

DPI Signal Routing Unit Registers

Table A-56. Group A Connections (Cont'd)

Selection Code	Signal	Description (Source selection)
01111 (0xF)	DPI_P14_O	External pin 14
10000 (0x10)	TIMER0_O	Timer0 output
10001 (0x11)	TIMER1_O	Timer1 output
10010 (0x12)	TIMER2_O	Timer2 output
10011 (0x13)	UART0_TX_O	UART0 transmitter output
10100 (0x14)	UART1_TX_O	UART1 transmitter output
10101–11111	Reserved	

Pin Assignment Signal Routing (SRU2_PINx, Group B)

Group B connections, shown in [Figure A-76](#) through [Figure A-78](#) and [Table A-57](#), are used to route output signals to the 14 DPI pins.

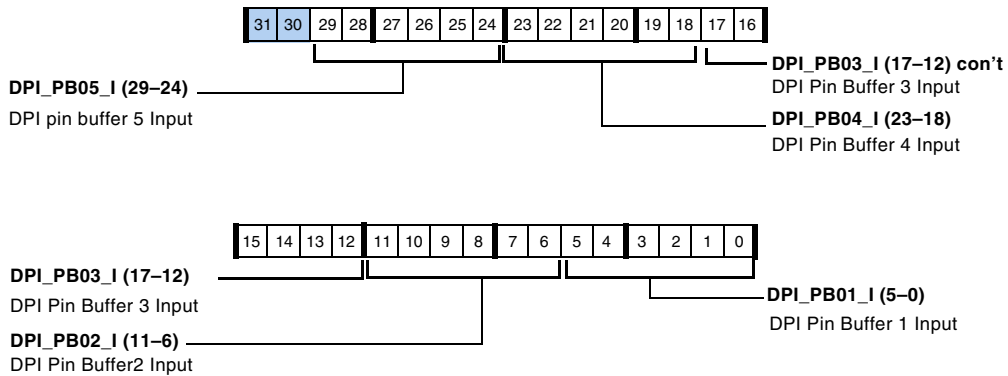

Figure A-76. SRU2_PIN0 Register (RW)

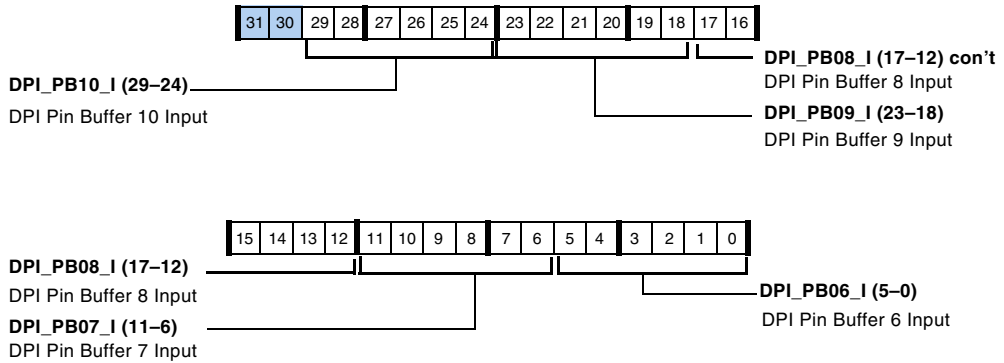

Figure A-77. SRU2_PIN1 Register (RW)

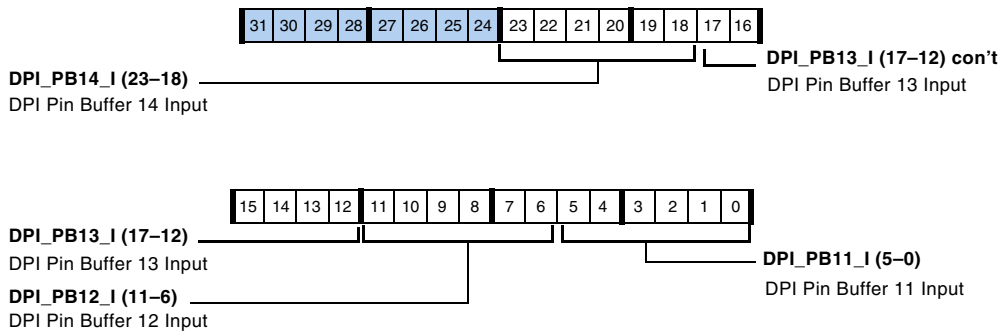

Figure A-78. SRU2_PIN2 Register (RW)

Table A-57. Group B Signals

Binary	Signal	Description (Source selection)
000000 (0x0)	LOW	Logic level low (0)
000001 (0x1)	HIGH	Logic level high (1)
000010 (0x2)	DPI_P01_O	External pin 1
000011 (0x3)	DPI_P02_O	External pin 2
000100 (0x4)	DPI_P03_O	External pin 3
000101 (0x5)	DPI_P04_O	External pin 4

DPI Signal Routing Unit Registers

Table A-57. Group B Signals (Cont'd)

Binary	Signal	Description (Source selection)
000110 (0x6)	DPI_P05_O	External pin 5
000111 (0x7)	DPI_P06_O	External pin 6
001000 (0x8)	DPI_P07_O	External pin 7
001001 (0x9)	DPI_P08_O	External pin 8
001010 (0xA)	DPI_P09_O	External pin 9
001011 (0xB)	DPI_P10_O	External pin 10
001100 (0xC)	DPI_P11_O	External pin 11
001101 (0xD)	DPI_P12_O	External pin 12
001110 (0xE)	DPI_P13_O	External pin 13
001111 (0xF)	DPI_P14_O	External pin 14
010000 (0x10)	TIMER0_O	Timer0 output
010001 (0x11)	TIMER1_O	Timer1 output
010010 (0x12)	TIMER2_O	Timer2 output
010011 (0x13)	UART0_TX_O	UART0 transmitter output
010100 (0x14)	UART1_TX_O	UART1 transmitter output
010101 (0x15)	SPI_MISO_O	MISO from SPI
010110 (0x16)	SPI_MOSI_O	MOSI from SPI
010111 (0x17)	SPI_CLK_O	Clock output from SPI
011000 (0x18)	SPI_FLG0_O	Slave select 0 from SPI
011001 (0x19)	SPI_FLG1_O	Slave select 1 from SPI
011010 (0x1A)	SPI_FLG2_O	Slave select 2 from SPI
011011 (0x1B)	SPI_FLG3_O	Slave select 3 from SPI
011100 (0x1C)	SPIB_MISO_O	MISO from SPIB
011101 (0x1D)	SPIB_MOSI_O	MOSI from SPIB
011110 (0x1E)	SPIB_CLK_O	Clock output from SPIB
011111 (0x1F)	SPIB_FLG0_O	Slave select 0 from SPIB

Table A-57. Group B Signals (Cont'd)

Binary	Signal	Description (Source selection)
100000 (0x20)	SPIB_FLG1_O	Slave select 1 from SPIB
100001 (0x21)	SPIB_FLG2_O	Slave select 2 from SPIB
100010 (0x22)	SPIB_FLG3_O	Slave select 3 from SPIB
100011 (0x23)	FLAG4_O	Flag 4 output
100100 (0x24)	FLAG5_O	Flag 5 output
100101 (0x25)	FLAG6_O	Flag 6 output
100110 (0x26)	FLAG7_O	Flag 7 output
100111 (0x27)	FLAG8_O	Flag 8 output
101000 (0x28)	FLAG9_O	Flag 9 output
101001 (0x29)	FLAG10_O	Flag 10 output
101010 (0x2A)	FLAG11_O	Flag 11 output
101011 (0x2B)	FLAG12_O	Flag 12 output
101100 (0x2C)	FLAG13_O	Flag 13 output
101101 (0x2D)	FLAG14_O	Flag 14 output
101110 (0x2E)	FLAG15_O	Flag 15 output
101111 (0x2F)	PCG_CLKC_O	Precision clock generator clock C out
110000 (0x30)	PCG_CLKD_O	Precision clock generator clock D out
110001 (0x31)	PCG_FSC_O	Precision clock generator frame sync C out
110010 (0x32)	PCG_FSD_O	Precision clock generator frame sync D out
110011–111111	Reserved	

DPI Signal Routing Unit Registers

Pin Enable Signal Routing (SRU2_PBENx, Group C)

Group C signals, shown in [Table A-58](#), are used to specify whether each DPI pin is used as an output or an input by setting the source for the pin buffer enable. When a pin buffer enable (`DPI_PBENxx_I`) is set (= 1), the signal present at the corresponding pin buffer input (`DPI_PBxx_I`) is driven off chip as an output. When a pin buffer enable is cleared (= 0), the signal present at the corresponding pin buffer input is ignored.

The pin enable control registers activate the drive buffer for each of the 14 DPI pins. When the pins are not enabled (driven), they can be used as inputs.

The registers that control group C settings are shown in [Figure A-79](#) through [Figure A-81](#).

 The TWI output must operate as an open-drain output, the DPI input pins used for TWI data and clock should be connected to logic level 0.

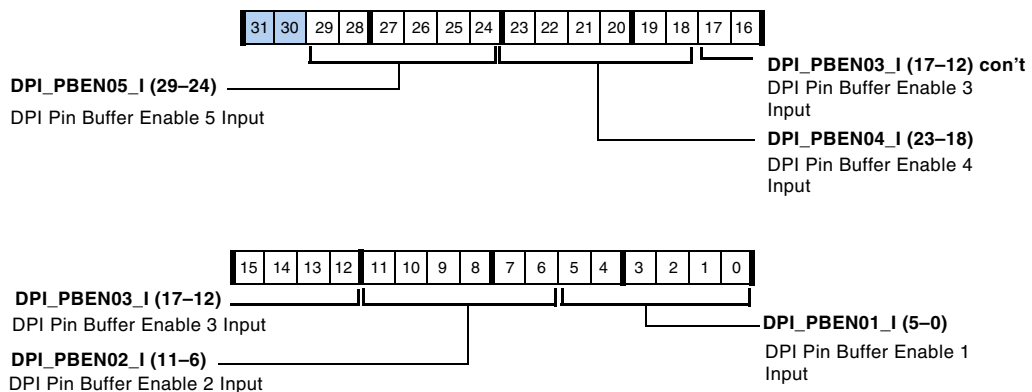

Figure A-79. SRU2_PBEN0 Register (RW)

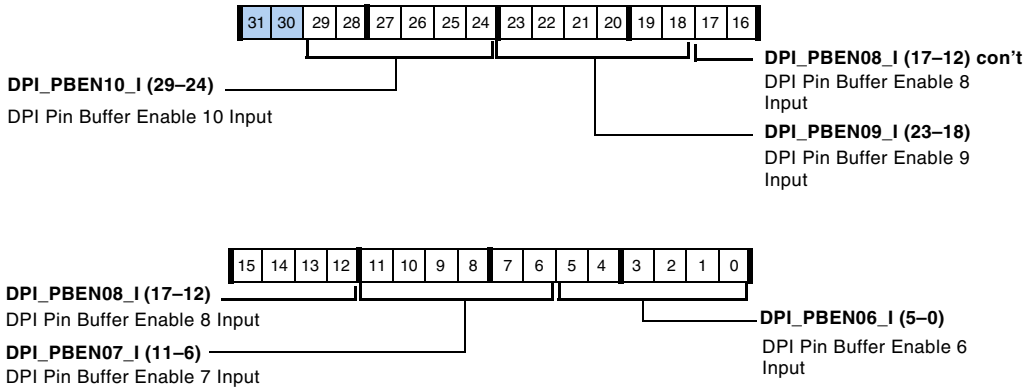

Figure A-80. SRU2_PBEN1 Register (RW)

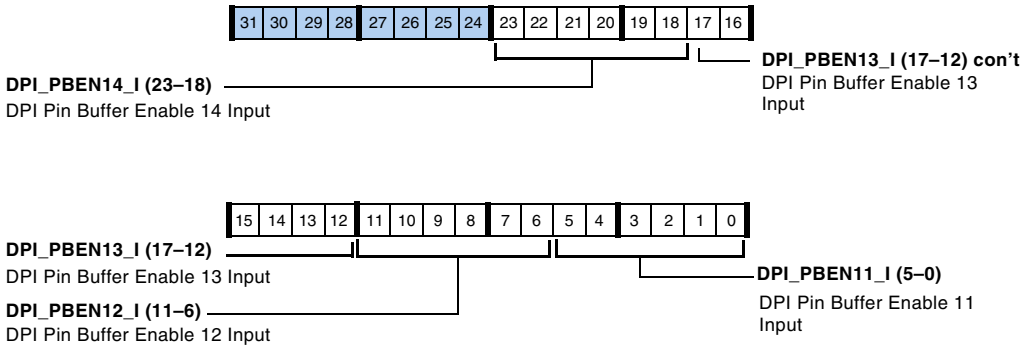

Figure A-81. SRU2_PBEN2 Register (RW)

Table A-58. Group C Signals

Binary	Signal	Description (Source selection)
000000 (0x0)	LOW	Logic level low (0)
000001 (0x1)	HIGH	Logic level high (1)
000010 (0x2)	MISCB0_O	Miscellaneous control 0
000011 (0x3)	MISCB1_O	Miscellaneous control 1
000100 (0x4)	MISCB2_O	Miscellaneous control 2

DPI Signal Routing Unit Registers

Table A-58. Group C Signals (Cont'd)

Binary	Signal	Description (Source selection)
000101 (0x5)	TIMER0_PBEN_O	Enable for timer 0 output
000110 (0x6)	TIMER1_PBEN_O	Enable for timer 1 output
000111 (0x7)	TIMER2_PBEN_O	Enable for timer 1 output
001000 (0x8)	UART0_TX_PBEN_0	Pin enable for UART 0 transmitter
001001 (0x9)	UART1_TX_PBEN_0	Pin enable for UART 1 transmitter
001010 (0xA)	SPIMISO_PBEN_O	Pin enable for MISO from SPI
001011 (0xB)	SPI MOSI_PBEN_O	Pin enable for MOSI from SPI
001100 (0xC)	SPI CLK_PBEN_O	Pin enable for CLK from SPI
001101 (0xD)	SPI FLG0_PBEN_O	Pin enable for slave select 0 from SPI
001110 (0xE)	SPI FLG1_PBEN_O	Pin enable for slave select 1 from SPI
001111 (0xF)	SPI FLG2_PBEN_O	Pin enable for slave select 2 from SPI
010000 (0x10)	SPI FLG3_PBEN_O	Pin enable for slave select 3 from SPI
010001 (0x11)	SPI BMISO_PBEN_O	Pin enable for MISO from SPIB
010010 (0x12)	SPI BMOSI_PBEN_O	Pin enable for MOSI from SPIB
010011 (0x13)	SPI BCLK_PBEN_O	Pin enable for CLK from SPIB
010100 (0x14)	SPI BFLG0_PBEN_O	Pin enable for slave select 0 from SPIB
010101 (0x15)	SPI BFLG1_PBEN_O	Pin enable for slave select 1 from SPIB
010110 (0x16)	SPI BFLG2_PBEN_O	Pin enable for slave select 2 from SPIB
010111 (0x17)	SPI BFLG3_PBEN_O	Pin enable for slave select 3 from SPIB
011000 (0x18)	FLAG4_PBEN_O	Pin enable for Flag 4 output
011001 (0x19)	FLAG5_PBEN_O	Pin enable for Flag 5 output
011010 (0x1A)	FLAG6_PBEN_O	Pin enable for Flag 6 output
011011 (0x1B)	FLAG7_PBEN_O	Pin enable for Flag 7 output
011100 (0x1C)	FLAG8_PBEN_O	Pin enable for Flag 8 output
011101 (0x1D)	FLAG9_PBEN_O	Pin enable for Flag 9 output
011110 (0x1E)	FLAG10_PBEN_O	Pin enable for Flag 10 output

Table A-58. Group C Signals (Cont'd)

Binary	Signal	Description (Source selection)
011111 (0x1F)	FLAG11_PBEN_O	Pin enable for Flag 11 output
100000 (0x20)	FLAG12_PBEN_O	Pin enable for Flag 12 output
100001 (0x21)	FLAG13_PBEN_O	Pin enable for Flag 13 output
100010 (0x22)	FLAG14_PBEN_O	Pin enable for Flag 14 output
100011 (0x23)	FLAG15_PBEN_O	Pin enable for Flag 15 output
100100 (0x24)	TWI_DATA_PBEN_O	Data output enable from TWI
100101 (0x25)	TWI_CLK_PBEN_O	Clock output enable from TWI
100110 (0x26)	MISCB3_O	Miscellaneous control 3
100111 (0x27)	MISCB4_O	Miscellaneous control 4
101000 (0x28)	MISCB5_O	Miscellaneous control 5
101001 (0x29)	MISCB6_O	Miscellaneous control 6
101010 (0x2A)	MISCB7_O	Miscellaneous control 7
101011 (0x2B)	MISCB8_O	Miscellaneous control 8
101100–111111	Reserved	

Pin Buffer Registers

The `DPI_PIN_PULLUP` and `DPI_PIN_STAT` control and return status of the DPI pin buffers.

DPI Signal Routing Unit Registers

Pin Buffer Status Register (DPI_PIN_STAT)

This 16-bit, read-only register is shown in [Figure A-82](#). Bits 13–0 of this register indicate the status of DPI_PB14–1. Reads from bits 15–14 always return 0. This register is updated at up to the PCLK/2 rate.

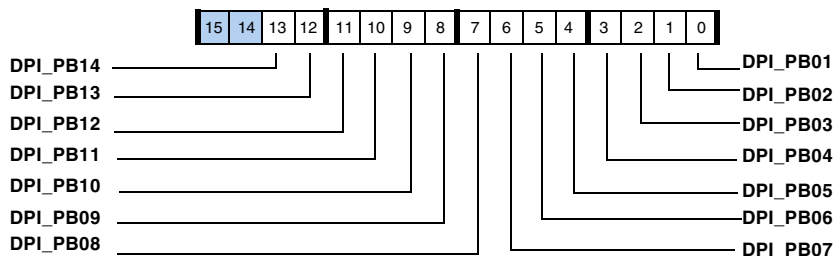

Figure A-82. DPI_PIN_STAT Register (RO)

Resistor Pull-up Enable Register (DPI_PIN_PULLUP)

This 16-bit read/write register is shown in [Figure A-83](#). Bits 13–0 of this register control the enabling/disabling pull-up resistor on DPI_PB14–1. Setting a bit to 1 enables a pull-up resistor on the corresponding pin. After $\overline{\text{RESET}}$, all pull-ups are enabled on all 14 DPI pins.

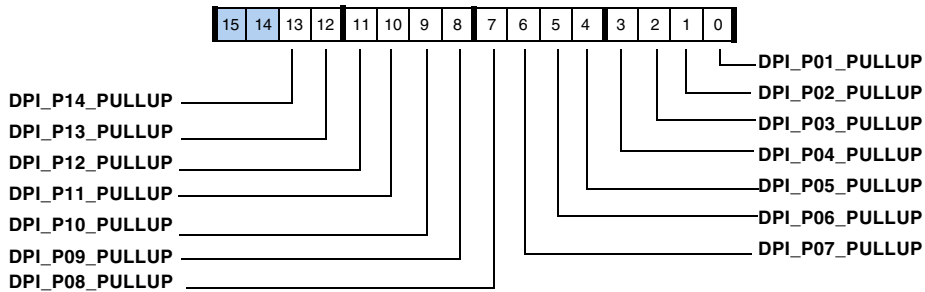

Figure A-83. DPI_PIN_PULLUP Register (RW)

Interrupt Controller Registers

The digital peripheral interface (DPI) also has an interrupt controller, similar to that in the DAI. All of these interrupts are combined into a single interrupt, namely `DPI_INT`. The `DPI_IMASK` register contains the status on individual interrupts. Apart from the `DPI_IRPTL` register, there are two additional registers, `DPI_IMASK_RE` and `DPI_IMASK_FE` that are used for interrupt latching.

All of the DPI interrupt registers are used primarily to provide the status of the interrupt controller. These registers are shown in [Figure A-84](#) and listed in [Table A-59](#). Note that for each of these registers the bit names and numbers are the same.

Table A-59. DPI Interrupt Registers

Register	Description
<code>DPI_IRPTL</code> (ROC)	Interrupt Latch Register
<code>DPI_IRPTL_SH</code> (RO)	<code>DPI_IMASK</code> Shadow Register. Reads of this register returns data in <code>DPI_IMASK</code> without clearing contents of the register.
<code>DPI_IMASK_RE</code> (RW)	Rising Edge Interrupt Mask Register
<code>DPI_IMASK_FE</code> (RW)	Falling Edge Interrupt Mask Register

Peripherals Routed Through the DPI

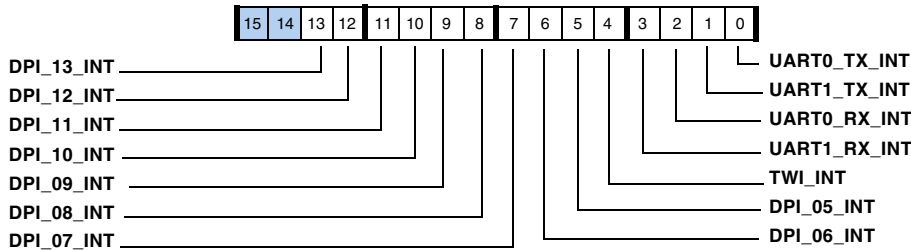

Figure A-84. DPI Interrupt Latch/Mask Register

Peripherals Routed Through the DPI

The following sections provide information on the peripherals that are explicitly routed through the digital peripheral interface.

Serial Peripheral Interface Registers

The following sections describe the registers associated with the two serial peripheral interfaces (SPIs). Note that the SPI port is routed through the DPI.

Control Registers (SPICTL, SPICTLB)

The SPI control (SPICTL) registers are used to configure and enable the SPI system. The bit settings for these registers are shown in [Figure A-85](#) and described in [Table A-60](#).

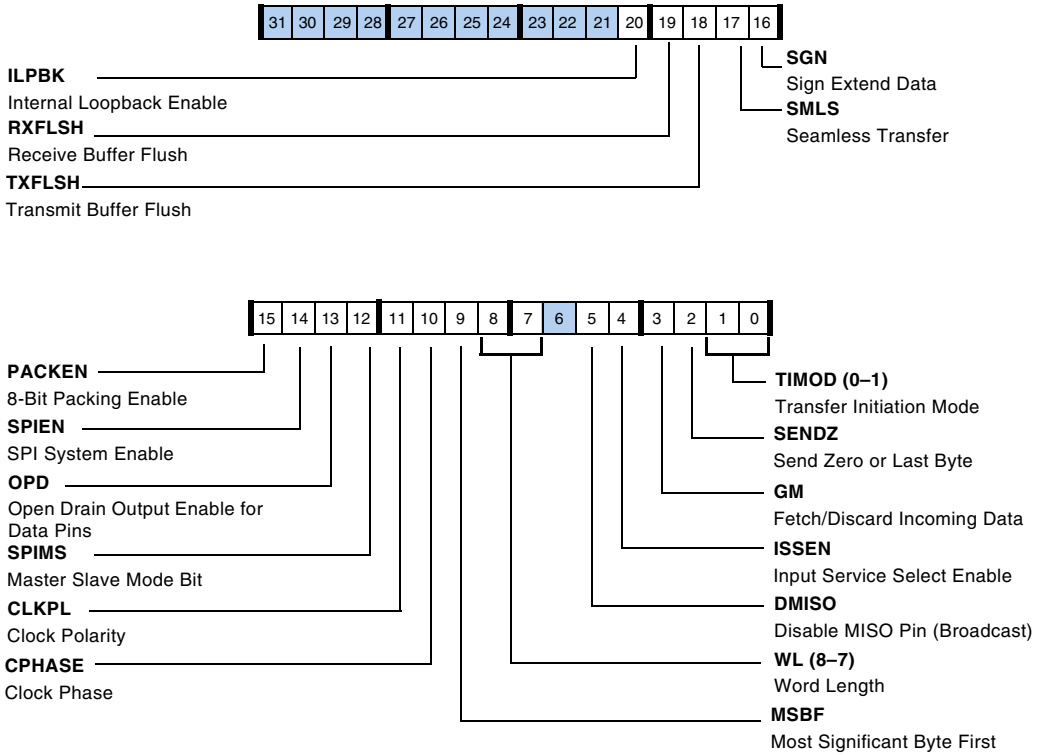

Figure A-85. SPICTL, SPICTLB Registers

Peripherals Routed Through the DPI

Table A-60. SPICTL Register Bit Descriptions (RW)

Bit	Name	Description
1–0	TIMOD	<p>Transfer Initiation Mode. Defines transfer initiation mode and interrupt generation.</p> <p>00 = Initiate transfer by read of receive buffer. Interrupt active when receive buffer is full.</p> <p>01 = Initiate transfer by write to transmit buffer. Interrupt active when transmit buffer is empty.</p> <p>10 = Enable DMA transfer mode. Interrupt configured by DMA.</p> <p>11 = Reserved</p>
2	SENDZ	<p>Send Zero. Send zero or the last word when TXSPI is empty.</p> <p>0 = Send last word</p> <p>1 = Send zeros</p>
3	GM	<p>Get Data. When RXSPI is full, get data or discard incoming data.</p> <p>0 = Discard incoming data</p> <p>1 = Get more data, overwrites the previous data</p>
4	ISSEN	<p>Input Service Select Enable. Enables service select (SPI_DS_I pin) for the SPI master. As master, $\overline{\text{SPIDS}}$ pin can serve as an error-detection input in a multi-master environment.</p> <p>0 = $\overline{\text{SPIDS}}$ pin is ignored</p> <p>1 = $\overline{\text{SPIDS}}$ pin is multi-master mode error input</p> <p>The SPIEN and SPIMS bits are cleared by hardware if the multi master error (SPIMME) bit in SPISTAT is set. For SPI slaves, the slave-select input (SPI_DS_I pin) acts like a reset for the internal SPI logic. For this reason, the SPI_DS_I pin must be error free.</p> <p>Note that SPI_DS_I pin operation depends on the SPI configuration. If the SPI is a slave, SPI_DS_I pin acts as the slave-select input. The state of this input pin is observable in bit 7 of the SPIFLGx register.</p>

Table A-60. SPICTL Register Bit Descriptions (RW) (Cont'd)

Bit	Name	Description
5	DMISO	<p>Disable MISO Output Pin. This is needed in an environment where a master wishes to transmit to various slaves at one time (broadcast). However, only one slave is allowed to transmit data back to the master. This bit should be set for all slaves, except the one from whom the master wishes to receive data.</p> <p>Different CPUs or processors can take turns being master, and one master may simultaneously shift data into multiple slaves (broadcast mode). However, only one slave may drive its output to write data back to the master at any given time. This must be enforced in the broadcast mode, where several slaves can be selected to receive data from the master, but only one slave can be enabled to send data back to the master. The (DMISO) bit disables MISO as an output.</p> <p>0 = SPIx_MISO_O enabled 1 = SPIx_MISO_O disabled</p>
6	Reserved	
8–7	WL	<p>Word Length. SPI port can transmit and receive three word widths: 00 = 8 bits 01 = 16 bits 10 = 32 bits</p> <p>8-bit word. SPI port sends out only the lower eight bits of the word written to the SPI buffer. For example when receiving, the SPI port packs the 8-bit word to the lower 32 bits of the RXSPI buffer while the upper bits in the registers are zeros. This code works only if the MSBF bit is zero in both the transmitter and receiver, and the SPICLK frequency is small. If MSBF = 1 in the transmitter and receiver, and SPICLK has a small frequency, the received words follow the order 0x12, 0x34, 0x56, 0x78.</p> <p>16-bit word. When transmitting, the SPI port sends out only the lower 16 bits of the word written to the SPI buffer. When receiving, the SPI port packs the 16-bit word to the lower 32 bits of the RXSPI buffer while the upper bits in the register are zeros.</p> <p>32-bit word. No packing of the RXSPI or TXSPI registers is necessary as the entire 32-bit register is used for the data word.</p>
9	MSBF	<p>Most Significant Byte First. 0 = LSB sent/received first 1 = MSB sent/received first</p>

Peripherals Routed Through the DPI

Table A-60. SPICTL Register Bit Descriptions (RW) (Cont'd)

Bit	Name	Description
10	CPHASE	Clock Phase. Selects the transfer format. 0 = SPICLK starts toggling at the middle of 1st data bit 1 = SPICLK starts toggling at the start of 1st data bit (default setting)
11	CLKPL	Clock Polarity. 0 = Active high SPICLK (SPICLK low is the idle state) 1 = Active low SPICLK (SPICLK high is the idle state) Note that the CLKPL/CPHASE bits define the SPI mode.
12	SPIMS	SPI Master Select. Configures SPI module as master or slave. 0 = Device is a slave device 1 = Device is a master device
13	OPD	Open Drain Output Enable. Enables open drain data output enable for MOSI and MISO pins. 0 = SPIx_MOSI/MISO_O driven 1 = SPIx_MOSI/MISO_O three state. In a multi-master/slave SPI system, the data output pins (MOSI and MISO) can be configured to behave as open drain drivers to prevent contention and possible damage to pin drivers. An external pull-up resistor is required on both the MOSI/MISO pins when this option is selected. When the OPD bit is set and the SPI ports are configured as masters, the SPIx_MOSI_O pin is three-stated. Instead the SPIx_MOSI_PBEN_O pin is driven and act as output enable pin. Note that the corresponding DPI input buffer pin should be tied to GND. Similarly, when OPD is set and the SPI ports are configured as slaves, the SPIx_MISO_O pin is three-stated. Instead the SPIx_MISO_PBEN_O pin is driven and act as output enable pin. Note that the corresponding DPI input buffer pin should be tied to GND. See “Pin Buffers as Open Drain” on page 6-11 .

Table A-60. SPICTL Register Bit Descriptions (RW) (Cont'd)

Bit	Name	Description
14	SPIEN	<p>SPI Port Enable. Enables the SPI port. If configured as a master (SPIMS=1) and SPIEN=0, the MOSI and SPICLK outputs are disabled, and the MISO input is ignored. If configured as a slave (SPIMS=0) and SPIEN=0, the MOSI and SPICLK inputs are ignored, and the MISO output is disabled.</p> <p>The SPIEN bit can also be used as a software reset of the internal SPI logic. An exception to this is the W1C-type (write 1-to-clear) bits in the SPISTATx registers. These bits remain set if they are already set.</p> <p>Note: always clear the W1C-type bits in SPISTATx registers before re-enabling the SPI, as these bits do not get cleared even if the SPI is disabled. This can be done by writing 0xFF to the SPISTATx registers. In the case of an SPIMME bit error, enable the SPI ports after SPI_DS_I pin is de-asserted.</p> <p>0 = SPI module is disabled 1 = SPI module is enabled</p>
15	PACKEN	<p>Packing Enable. The SPI unpacks data when it transmits and packs data when it receives. In order to communicate with 8-bit SPI devices and store 8-bit words in internal memory, a packed transfer feature is built into the SPI port.</p> <p>0 = No packing 1 = 8 to 16-bit packing</p> <p>Note: This bit may be 1 only when WL = 00 (8-bit transfer). When in transmit mode, the PACKEN bit unpacks data. When packing is enabled, two 8-bit words are packed into one 32-bit word. When the SPI port is transmitting, two 8-bit words are unpacked from one 32-bit word. When receiving, words are packed into one 32-bit word from two 8-bit words. The value 0xXXLMXXJK (where XX is any random value and JK and LM are data words to be transmitted out of the SPI port) is written to the TXSPI register. The processor transmits 0xJK first and then transmits 0xLM.</p> <p>The receiver packs the two words received, 0xJK and then 0xLM, into a 32-bit word. They appear in the RXSPI register as: 0x00LM00JK => if SGN is configured to 0 or L, J < 7 0xFFLMFFJK => if SGN is configured to 1 and L, J > 7</p>
16	SGN	<p>Sign Extend.</p> <p>0 = No sign extension 1 = Sign extension</p>

Peripherals Routed Through the DPI

Table A-60. SPICTL Register Bit Descriptions (RW) (Cont'd)

Bit	Name	Description
17	SMLS	Seamless Transfer. 0 = Seamless transfer disabled. After each word transfer there is a delay before the next word transfer starts. The delay is 2.5 SPICLK cycles 1 = Seamless transfer enabled. There is no delay before the next word starts, a seamless operation. Not supported in mode TIMOD1-0 = 00 and CPHASE=0 for all modes.
18 (WO C)	TXFLSH	Flush Transmit Buffer. Clears the TXS bit. 0 = TXSPI not cleared 1 = TXSPI cleared
19 (WO C)	RXFLSH	Flush Receive Buffer. Clears the RXS bit. 0 = RXSPI not cleared 1 = RXSPI cleared
20	ILPBK	Internal Loop Back. This mode interconnects the MOSI with the MISO pins internally. In this mode the SPIMS bit must be set. 0 = No internal loopback 1 = Internal loopback enabled
31–23	Reserved	

DMA Configuration Registers (SPIDMAC, SPIDMACB)

These 17-bit SPI registers are used to control DMA transfers and are shown in [Figure A-86](#) and described in [Table A-61](#).

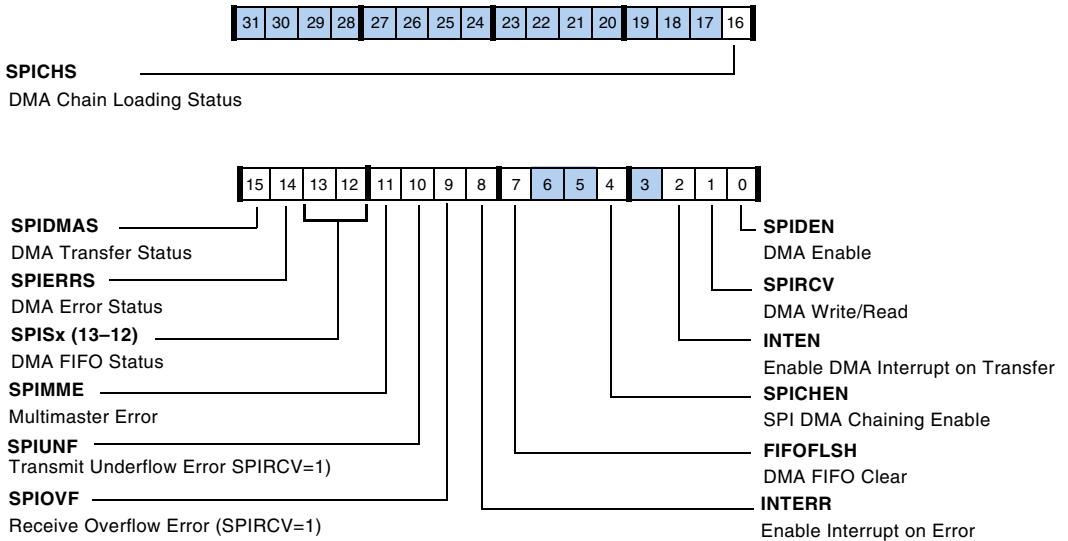

Figure A-86. SPIDMAC, SPIDMACB Registers

Table A-61. SPIDMAC, SPIDMACB Register Bit Descriptions (RW)

Bit	Name	Description
0	SPIDEN	DMA Enable. 0 = Disable 1 = Enable
1	SPIRCV	DMA Write/Read. 0 = Memory write (SPI transmit) 1 = Memory read (SPI receive)
2	INTEN	Enable DMA Interrupt on Transfer. 0 = Disable 1 = Enable
3	Reserved	

Peripherals Routed Through the DPI

Table A-61. SPIDMAC, SPIDMACB Register Bit Descriptions (RW)

Bit	Name	Description
4	SPICHEN	SPI DMA Chaining Enable. 0 = Disable 1 = Enable
6–5	Reserved	
7 (WOC)	FIFOFLSH	DMA FIFO Clear. Clears the SPIS bit. 0 = Disable 1 = Enable
8	INTERR	Enable Interrupt on Error. 0 = Disable 1 = Enable
9 (RO)	SPIOVF	Receive OverFlow Error (SPIRCV = 1). 0 = Successful transfer 1 = Error – data received with RXSPI full
10 (RO)	SPIUNF	Transmit Underflow Error (SPIRCV = 0). 0 = Successful transfer 1 = Error occurred in transmission with no new data in TXSPI.
11 (RO)	SPIMME	Multimaster Error. 0 = Successful transfer 1 = Error during transfer
13–12 (RO)	SPIIS	DMA FIFO Status. 00 = FIFO empty 11 = FIFO full 10 = FIFO partially full 01 = Reserved
14 (RO)	SPIERRS	DMA Error Status. This bit is set if SPIOVF, SPIUNF or SPIMME bits are set. 0 = Successful DMA transfer 1 = Errors during DMA transfer
15 (RO)	SPIDMAS	DMA Transfer Status. 0 = DMA idle 1 = DMA in progress

Table A-61. SPIDMAC, SPIDMACB Register Bit Descriptions (RW)

Bit	Name	Description
16 (RO)	SPICHS	DMA Chain Loading Status. 0 = No chain loading 1 = Chain loading in progress
31–17	Reserved	

Baud Rate Registers (SPIBAUD, SPIBAUDB)

These SPI registers are used to set the bit transfer rate for a master device. When configured as slaves, the value written to these registers is ignored. The (SPIBAUD_x) registers can be read from or written to at any time. Bit descriptions are provided in [Table A-62](#).

Table A-62. SPIBAUD, SPIBAUDB Register Bit Descriptions (RW)

Bit	Name	Description
0	Reserved	
15–1	BAUDR	Baud Rate Enable. Enables the SPICLK per the equation: SPICLK baud rate = PCLK / (4 x BAUDR) Default = 0
31–19	Reserved	

Status Registers (SPISTAT, SPISTATB)

The SPISTAT and SPISTATB registers are used to detect when an SPI transfer is complete, if transmission/reception errors occur, and the status of the TXSPI and RXSPI FIFOs. The bit settings for these registers are shown in [Figure A-87](#) and described in [Table A-63](#).

Peripherals Routed Through the DPI

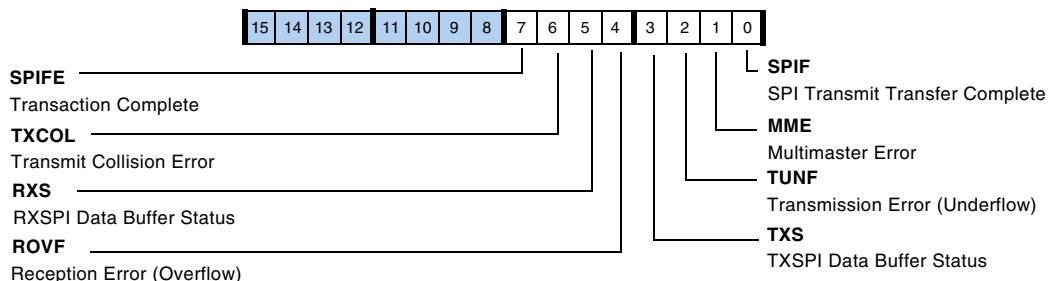

Figure A-87. SPISTAT, SPISTATB Registers

Table A-63. SPISTAT Register Bit Descriptions (RO)

Bit	Name	Description
0 (RO)	SPIF	SPI Transmit or Receive Transfer Complete. SPIF is set when an SPI single-word transfer is complete.
1 (W1C)	MME	Multimaster Error or Mode-fault Error. MME is set in a master device when some other device tries to become the master. In multi-master mode, if the $\overline{\text{SPIDS}}$ input signal of a master is asserted (Low) an error has occurred. This means that another device is also trying to be the master. Clears the SPIMME bit.
2 (W1C)	TUNF	Transmission Error. TUNF is set when transmission occurred with no new data in TXSPI register. The TUNF bit (2) is set when all of the conditions of transmission are met and there is no new data in TXSPI (TXSPI is empty). In this case, the transmission contents depend on the state of the SENDZ bit in the SPICTL register. Clears the SPIUNF bit.
3 (RO)	TXS	Transmit Data Buffer Status. TXSPI data buffer status. 0 = Empty 1 = Full
4 (W1C)	ROVF	Reception Error. ROVF is set when data is received with receive buffer full. Clears the SPIOVF bit.

Table A-63. SPISTAT Register Bit Descriptions (RO) (Cont'd)

Bit	Name	Description
5 (RO)	RXS	<p>Receive Data Buffer Status. The ROVF flag (bit 4) is when a new transfer has completed before the previous data is read from the RXSPI register. This bit indicates that a new word was received while the receive buffer was full. The ROVF flag is cleared by a W1C-type software operation. The state of the GM bit in the SPICTL register determines whether the RXSPI register is updated with the newly received data or whether that new data is discarded.</p> <p>0 = Empty 1 = Full</p>
6 (W1C)	TXCOL	<p>Transmit Collision Error. When TXCOL is set, it is possible that corrupt data was transmitted.</p> <p>The TXCOL flag (bit 6) is set when a write to the TXSPI register coincides with the load of the shift register. The write to TXSPI can be via the software or the DMA. This bit indicates that corrupt data may have been loaded into the shift register and transmitted. In this case, the data in TXSPI may not match what was transmitted. This error can easily be avoided by proper software control. The TXCOL bit is cleared by a W1C-type software operation.</p> <p>Note that this bit is never set when the SPI is configured as a slave with CPHASE = 0. The collision may occur, but it cannot be detected.</p>
7 (RO)	SPIFE	<p>External Transaction Complete. Set (= 1) when the SPI transaction is complete on the external interface (especially DMA).</p>
31–8	Reserved	

Flags Registers (SPIFLG, SPIFLGB)

The SPIFLG and SPIFLGB registers are used to enable individual SPI slave-select lines when the SPI is enabled as a master. This register is ignored if the SPI is programmed as a slave. The bit settings for these registers are shown in [Figure A-88](#) and described in [Table A-64](#). Note that the default setting of both registers is dependant on master, slave, and boot mode conditions.

Peripherals Routed Through the DPI

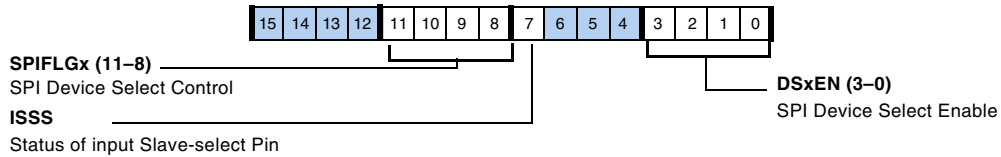

Figure A-88. SPIFLG, SPIFLGB Registers

Table A-64. SPIFLG, SPIFLGB Register Bit Descriptions (RW)

Bit	Name	Description
3-0	DSxEN	SPI Device Select Enable. Enables or disables the corresponding output signal to the SRU2 be used for SPI slave-select. 0 = Disable SPIFLGx output enable 1 = Enable SPIFLGx output enable Note DS0EN bit is set in SPI master mode only.
6-4	Reserved	
7 (RO)	ISSS	Input Slave Service Select. Reflects the service selection for the slave-select input pin (\overline{SPIDS}). 0 = \overline{SPIDS} pin ignored 1 = \overline{SPIDS} pin used as multi-master error detection (default for SPI only)
11-8	SPIFLGx	SPI Device Select Control. Selects (if cleared, = 0) a corresponding DPI pin (depending on pin routing) output to be asserted for an SPI slave-select. For CPHASE=1, these bits require SW control to toggle the chip select. For CPHASE=0, there is automatic HW control. 0000 = all SPIFLGx cleared 1111 = all SPIFLGx set (default)
12-31	Reserved	

UART Control and Status Registers

The processor provides a set of PC-style, industry-standard control and status registers for each UART. These IOP registers are byte-wide registers that are mapped as half-words with the most significant byte zero-filled.

Line Control Register (UARTxLCR)

The UART line control register (UARTxLCR, shown in [Figure A-89](#) and described in [Table A-65](#)) controls the format of received and transmitted character frames.

i Some UART registers share the same IOP address. The UARTxDLL registers are mapped to the same address as the UARTxTHR and UARTxRBR registers. The UARTxDLH registers are mapped to the same address as the interrupt enable registers (UARTxIER). Note that the UARTDLAB bit in the UARTxLCR register must be set before the UART divisor latch registers can be accessed. If the UARTDLAB bit is cleared, access to the UARTxTHR and UARTxRBR or UARTxIER registers occurs.

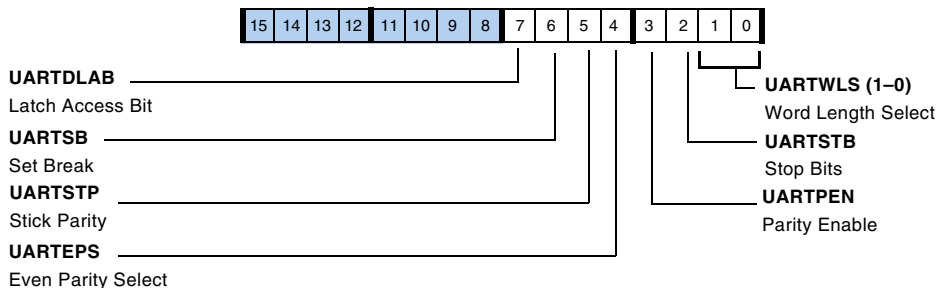

Figure A-89. UARTxLCR Register

Peripherals Routed Through the DPI

Table A-65. UART_xLCR Register Bit Descriptions (RW)

Bit	Name	Description
1-0	UARTWLS	Word Length Select. 00 = 5-bit word (UARTWLS5) 01 = 6-bit word (UARTWLS6) 10 = 7-bit word (UARTWLS7) 11 = 8-bit word (UARTWLS8)
2	UARTSTB	Stop Bits. 0 = 1 stop bit 1 = 2 stop bits for non-5-bit word length or 1 1/2 stop bits for 5-bit word length
3	UARTPEN	Parity Enable. 0 = Parity not transmitted or checked 1 = Transmit and check parity
4	UARTEPS	Even Parity Select. 0 = Odd parity when PEN = 1 and STP = 0 1 = Even parity when PEN = 1 and STP = 0
5	UARTSTP	Stick Parity. Forces parity to defined value if set and PEN = 1 0 = Parity transmitted and checked as 1 1 = Parity transmitted and checked as 0
6	UARTSB	Set Break. The UART transmit pin is driven high normally. This bit is used to force the transmit pin to zero. This bit functions even when the UART is not enabled. Using this bit the UART TX pin can be used as a flag pin when the UART is not used. 0 = No force 1 = Force UART _x TX _O pin to 0.
7	UARTDLAB	Divisor Latch Access Bit. Because some IOP registers share the same address, this bit provides access as follows. 0 = Enable access to UART _x THR, UART _x RBR, and UART _I IER registers 1 = Enable access to UART _x DLL and UART _x DLH registers

Line Status Registers (UARTxLSR, UARTxLSRSH)

The UART line status register (UARTxLSR) contains UART status information as shown in [Figure A-90](#) and described in [Table A-66](#). There is also a shadow register, UARTxLSRSH, that allows programs to read the contents of the corresponding main register without affecting the status the UART.

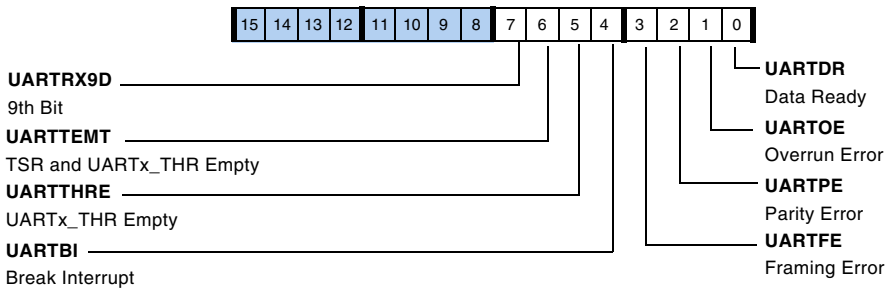

Figure A-90. UARTxLSR/SH Register

Table A-66. UARTxLSR/UARTxLSRSH Register Bit Descriptions (RO)

Bit	Name	Description
0	UARTDR	Data Ready. This bit is cleared when the UART receive buffer (UARTxRBR) is read. 0 = No new data 1 = UARTx_RBR holds new data
1 (ROC ¹)	UARTOE	Overrun Error. 0 = No overrun 1 = UARTx_RBR overwritten before read
2 (ROC ¹)	UARTPE	Parity Error. 0 = No parity error 1 = Parity error
3 (ROC ¹)	UARTFE	Framing Error. 0 = N error 1 = Invalid stop bit error

Peripherals Routed Through the DPI

Table A-66. UART_xLSR/UART_xLSRSH Register Bit Descriptions (RO) (Cont'd)

Bit	Name	Description
4 (ROC ¹)	UARTBI	Break Interrupt. This bit indicates the UART RX pin was held low for more than the max word length. 0 = No break interrupt 1 = Break interrupt.
5	UARTTHRE	UART_x_THR Empty. The UARTTHRE bit indicates that the UART transmit channel is ready for new data, and software can write to the UART _x THR register. Writes to UART _x THR clear the UARTTHRE bit. It is set again when data is copied from UART _x THR to the transmit shift register (UART _x TSR). 0 = Not empty 1 = Empty (default)
6	UARTTEMT	TSR and UART_x_THR Empty. This bit can be evaluated to determine whether a recently initiated transmit operation has been completed. 0 = Full 1 = Both empty (default)
7	UARTRX9D	9th bit of the received character-address detect

¹ These bits are read-only in the UART_xLRSRSH (shadow) register.

Interrupt Enable Register (UART_xIER)

The interrupt enable register (UART_xIER) is used to enable requests for system handling of empty or full states of UART data registers. Unless polling is used as a means of action, the UARTRBFIE and/or UARTTBEIE bits in this register are normally set ([Figure A-91](#)).

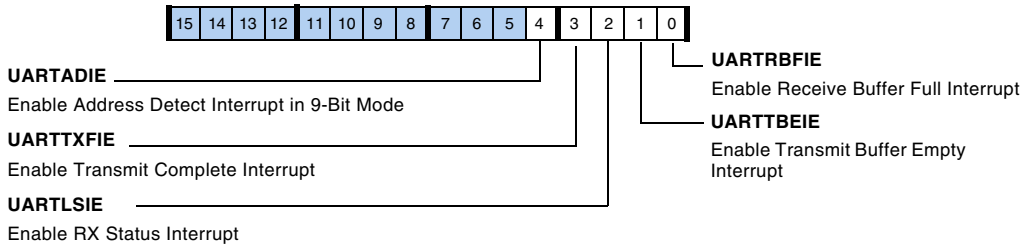

Figure A-91. UARTxIER Register

Table A-67. UARTxIER Register Bit Descriptions (RW)

Bit	Name	Description
0	UARTRBFIE	Enable Receive Buffer Full Interrupt. 0 = No interrupt 1 = Generate RX interrupt if DR bit in UART_LSR is set
1	UARTTBEIE	Enable Transmit Buffer Empty Interrupt. 0 = No interrupt 1 = Generate TX interrupt if THRE bit in UART_LSR is set
2	UARLTSEIE	Enable RX Status Interrupt. 0 = No interrupt 1 = Generate line status interrupt if any of UART_LSR[4–1] is set
3	UARTRBFIE	Enable Transmit Complete Interrupt. 0 = No interrupt 1 = Generate TX interrupt if TEMT bit in UART_LSR is set
4	UARTADIE	Enable Address Detect Interrupt in 9-Bit Mode. 0 = No interrupt 1 = Generate RX interrupt when address is detected in 9-bit mode

Interrupt Identification Registers (UARTxIIR, UARTxIIRSH)

For legacy reasons, the interrupt identification register (UARTxIIR, shown in [Figure A-92](#)) still reflects the UART interrupt status. Legacy operations may require bundling all UART interrupt sources to a single interrupt channel and servicing them all by the same software routine. This can be established by globally assigning all UART interrupts to the same

Peripherals Routed Through the DPI

interrupt priority. For more information, see Appendix B, Peripheral Interrupt Control.

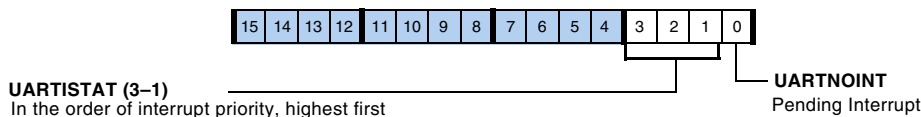

Figure A-92. UARTxIIRSH Register

Table A-68. UARTxIIR Register Bit Descriptions (RO)

Bit	Name	Description
0	UARTNOINT	Pending Interrupt. When UARTNOINT bit cleared it signals that an interrupt is pending. 0 = Interrupt pending 1 = No interrupt pending (default)
3-1 (ROC ¹)	UARTISTAT	In the Order of Interrupt Priority, Highest First. 011 = Receive line status. 100 = Address detect. 010 = Receive data ready. 001 = UART_THR empty. Write UART_THR or read UART_IIR to clear interrupt request, when priority = 4. 000 = UART THR and TSR empty (TEMT = transmit complete). Write UART_THR or read UART_IIR to clear interrupt request, when priority = 5. In the case where both interrupts are signalling, the UARTxIIR register reads 0x06. When a UART interrupt is pending, the interrupt service routine (ISR) needs to clear the interrupt latch explicitly.

¹ These bits are read-only in the UARTxLRSH (shadow) register.

There is also a shadow register, UARTxIIRSH. This register allows programs to read the contents of the corresponding main register without affecting the status of the UART.

Divisor Latch Registers (UARTxDLL, UARTxDLH)

The bit rate is characterized by the peripheral clock (PCLK) and the 16-bit divisor. The divisor is split into the UART divisor latch low byte register (UARTxDLL) and the UART divisor latch high byte register (UARTxDLH), both shown in [Figure A-93](#).

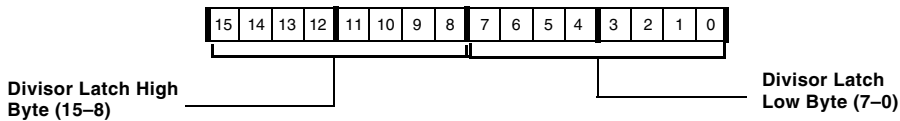

Figure A-93. UART Divisor Latch Registers

Scratch Register (UARTxSCR)

This register ([Figure A-94](#)) is used for general-purpose and does not control the UART hardware in any way. This register can be used to temporarily hold data.

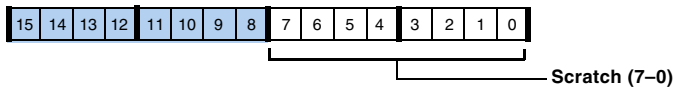

Figure A-94. UART Scratch Registers

Mode Register (UARTxMODE)

The UART mode register controls miscellaneous settings as shown in [Figure A-95](#) and described [Table A-69](#).

Peripherals Routed Through the DPI

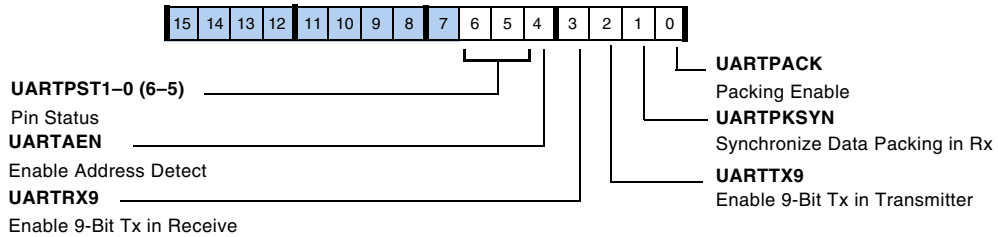

Figure A-95. UART Mode Register

Table A-69. UART Mode Register Bit Descriptions (RW)

Bit	Name	Description
0	UARTPACK	Packing Enable. 0 = No pack 1 = Packing enabled. Consecutive data words (example 0xAB and 0xCD) are packed as 0x00CD 00AB in the receiver, and 0x00CD 00AB is transmitted as two words of 0xAB and 0xCD successively from the transmitter. For more information, see “Data Packing” on page 14-8.
1 (WO)	UARTPKSYN	Synchronize Data Packing in RX. When written with a 1, the next data byte goes to the lower byte position of the UART_RBR register. Always returns zero on reads.
2	UARTRX9	Enable 9-Bit Tx in Transmitter. 0 = I/O mode 1 = 9-bit transmission in transmitter
3	UARTRX9	Enable 9-Bit Tx in Receiver. 0 = I/O mode 1 = 9-bit transmission in receiver
4	UARTAEN	Enable Address Detect (If RX9 = 1). 0 = Disable address detection; all bytes are received 1 = Enable address detection; interrupt and load of UART_RBR when RX9D is set
6-5 (RO)	UARTPST1-0	TX Pin Status. Defines the disabled transmit pin status. 00 = UARTx_TX_O is low 01 = UARTx_TX_O is three-stated (default) 10 = UARTx_TX_O is three-stated 11 = UARTx_TX_O is high

Buffer Control Registers (UARTxTXCTL, UARTxRXCTL)

Use these registers (described in [Table A-70](#) and [Table A-71](#)) to enable the UART buffers, standard DMA, and DMA chaining.

Table A-70. UARTxTXCTL Register Descriptions (RW)

Bit	Name	Description
0	UARTEN	Transmit Buffer Enable. 0 = Clear transmit buffer 1 = Enables the transmit buffer (this bit needs to be enabled regardless of core or DMA access)
1	UARTDEN	DMA Enable. 0 = Disable DMA 1 = Enable DMA on the specified channel
2	UARTCHEN	Chain Pointer DMA Enable. 0 = Disable chained DMA 1 = Enable chained DMA on the specified channel

Table A-71. UARTxRXCTL Register Descriptions (RW)

Bit	Name	Description
0	UARTEN	Receive Buffer Enable. 0 = Clears the receive buffer 1 = Enables the receive buffer (this bit needs to be enabled regardless of core or DMA access)
1	UARTDEN	DMA Enable. 0 = Disables DMA 1 = Enables DMA on the specified channel
2	UARTCHEN	Chain Pointer DMA Enable. 0 = Disable chained DMA 1 = Enable chained DMA on the specified channel

Peripherals Routed Through the DPI

DMA Status Registers (UARTxTXSTAT, UARTxRXSTAT)

These registers (described in [Table A-72](#) and [Table A-73](#)) provide DMA status information.

Table A-72. UARTxTXSTAT Register Bit Descriptions (RO)

Bit	Name	Description
0	Reserved	
1	UARTDMASTAT	DMA Status. Provides DMA status. 0 = TX DMA is inactive 1 = TX DMA is active
2	UARTCHSTAT	DMA Chaining Status. Provides DMA chaining status. 0 = TX DMA chain loading is inactive 1 = TX DMA chain loading is active

Table A-73. UARTxRXSTAT Register Bit Descriptions (RO)

Bit	Name	Description
0	UARTERRIRQ	Receive Channel Error Interrupt. 0 = No error interrupt 1 = Error interrupt generated due to receive error (parity/over-run/framing). Cleared on a read of the LSR register.
1	UARTDMASTAT	DMA Status. Provides DMA status. 0 = RX DMA is inactive 1 = RX DMA is active
2	UARTCHSTAT	DMA Chaining Status. Provides DMA chaining status. 0 = RX DMA chain loading is inactive 1 = RX DMA chain loading is active

Two-Wire Interface Registers

The two-wire interface (TWI) registers (described in [Table A-73](#)) provide all control and status bits for this peripheral. Status bits can be updated by their respective functional blocks.

Master Internal Time Register (TWIMITR)

The TWI master internal time register (TWIMITR, shown in [Figure A-96](#) and described in [Table A-74](#)) is used to enable the TWI module as well as to establish a relationship between the peripheral clock (PCLK) and the TWI controller’s internally-timed events. The internal time reference is derived from PCLK using the prescaled value:

$$\text{PRESCALE} = f_{\text{PCLK}} / 10 \text{ MHz}$$

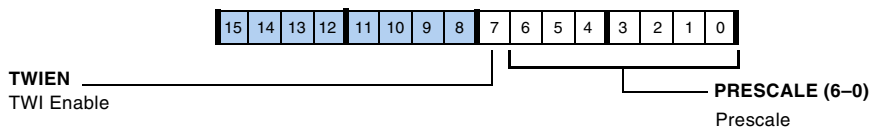

Figure A-96. Master Internal Time Register

Table A-74. Master Internal Time Register Bit Descriptions (RW)

Bit	Name	Description
0–6	PRESCALE	Prescale. The number of peripheral clock (PCLK) periods used in the generation of one internal time reference. The value of PRESCALE must be set to create an internal time reference with a period of 10 MHz. This is represented as a 7-bit binary value.
7	TWIEN	TWI Enable. Must be set for slave or master mode operation. It is recommended that this bit be set at the time PRESCALE is initialized and remain set. This guarantees accurate operation of bus busy detection logic. 0 = Disable TWI 1 = Enable TWI master and slave mode operation.

Peripherals Routed Through the DPI

Clock Divider Register (TWIDIV)

During master mode operation, the SCL clock divider register (TWIDIV shown in [Figure A-97](#) and described in [Table A-75](#)) values are used to create the high and low durations of the serial clock (SCL). Serial clock frequencies can vary from 400 KHz to less than 20 KHz. The resolution of the clock generated is 1/10 MHz or 100 ns.

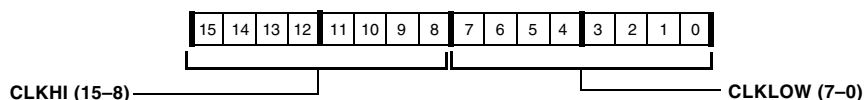

Figure A-97. TWIDIV Register

Table A-75. TWIDIV Register Bit Descriptions (RW)

Bit	Name	Description
7-0	CLKLOW	Clock Low. Number of internal time reference periods the serial clock (TWI_CLK) is held low. Represented as an 8-bit binary value.
15-8	CLKHI	Clock High. Number of internal time reference periods the serial clock (TWI_CLK) waits before a new clock low period begins (assuming a single master). Represented as an 8-bit binary value.

Slave Mode Control Register (TWISCTL)

The TWI slave mode control register (TWISCTL) shown in [Figure A-98](#) and described in [Table A-76](#), controls the logic associated with slave mode operation. Settings in this register do not affect master mode operation and should not be modified to control master mode functionality.

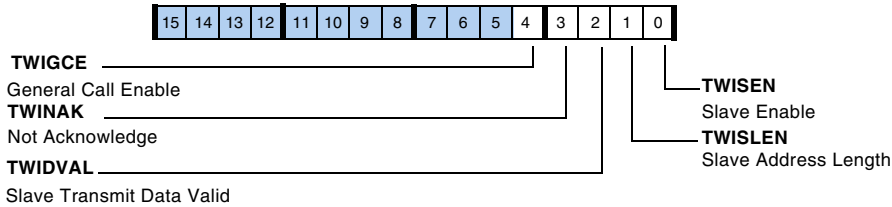

Figure A-98. TWISCTL Register

Table A-76. Slave Mode Control Register Bit Descriptions (RW)

Bit	Name	Description
0	TWISEN	Slave Enable. 0 = The slave is not enabled. No attempt is made to identify a valid address. If cleared during a valid transfer, clock stretching ceases, the serial data line is released and the current byte is not acknowledged. 1 = The slave is enabled. Enabling slave and master modes of operation concurrently is allowed.
1	TWISLEN	Slave Address Length. 0 = Address is a 7-bit address 1 = Reserved. Setting this bit to 1 causes unpredictable behavior.
2	TWIDVAL	Slave Transmit Data Valid. 0 = Data in the transmit FIFO is for master mode transmits and is not allowed to be used during a slave transmit, and the transmit FIFO is treated as if it is empty. 1 = Data in the transmit FIFO is available for a slave transmission.
3	TWINAK	Not Acknowledged. 0 = Slave receive transfer generates an ACK at the conclusion of a data transfer. 1 = Slave receive transfer generates a data NAK at the conclusion of a data transfer. The slave is still considered to be addressed.
4	TWIGCE	General Call Enable. General call address detection is available only when slave mode is enabled. 0 = General call address matching is not enabled 1 = General call address matching is enabled. Regardless of the selected address length of slave address, a general call slave receive transfer is accepted. All status and interrupt source bits associated with transfers are updated.

Peripherals Routed Through the DPI

Slave Address Register (TWISADDR)

The TWI slave mode address register (TWISADDR, shown in [Figure A-99](#)) holds the slave mode address, which is the valid address that the slave-enabled TWI controller responds to. The TWI controller compares this value with the received address during the addressing phase of a transfer.

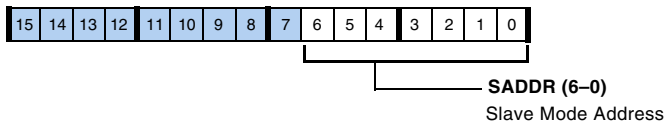

Figure A-99. TWISADDR Register (RW)

Slave Status Register (TWISSTAT)

During and at the conclusion of slave mode transfers, the TWI slave mode status register (TWISSTAT, shown in [Figure A-100](#)) holds information on the current transfer. Generally slave mode status bits are not associated with the generation of interrupts. Master mode operation does not affect the slave mode status bits.

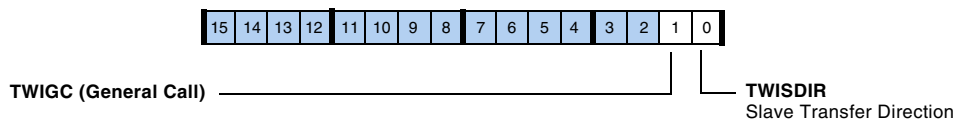

Figure A-100. TWISSTAT Register (RO)

Master Control Register (TWIMCTL)

The TWI master mode control register (TWIMCTL, shown in [Figure A-101](#) and described in [Table A-77](#)) controls the logic associated with master mode operation. Bits in this register do not affect slave mode operation and should not be modified to control slave mode functionality.

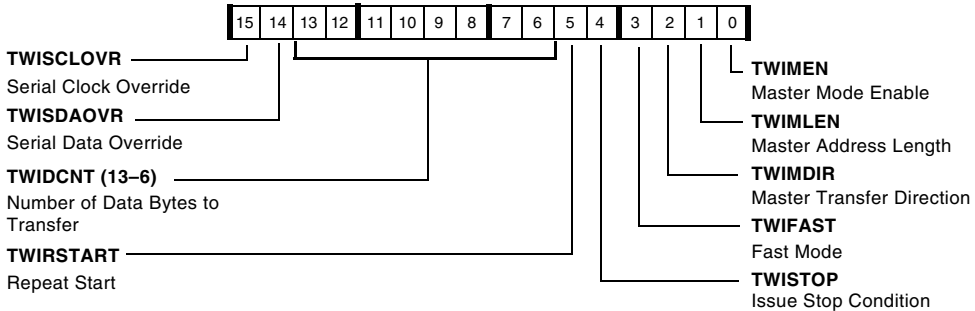

Figure A-101. TWIMCTL Register

Table A-77. TWIMCTL Register Bit Descriptions (RW)

Bit	Name	Description
0	TWIMEN	Master Mode Enable. Clears itself at the completion of a transfer. This includes transfers terminated due to errors. 0 = Master mode functionality is disabled. If MEN is cleared during operation, the transfer is aborted and all logic associated with master mode transfers are reset. Serial data and serial clock (TWI_DATA, TWI_CLOCK) are no longer driven. Write 1-to-clear status bits are not effected. 1 = Master mode functionality is enabled. A START condition is generated if the bus is idle.
1	TWIMLEN	Master Address Length. 0 = Address is 7-bit 1 = Reserved. Setting this bit to one causes unpredictable behavior
2	TWIMDIR	Master Transfer Direction. 0 = The initiated transfer is master transmit 1 = The initiated transfer is master receive
3	TWIFAST	Fast Mode. 0 = Standard mode timing specifications in use 1 = Fast mode timing specifications in use

Peripherals Routed Through the DPI

Table A-77. TWIMCTL Register Bit Descriptions (RW) (Cont'd)

Bit	Name	Description
4	TWISTOP	Issue STOP Condition. 0 = Normal transfer operation 1 = The transfer concludes as soon as possible avoiding any error conditions (as if data transfer count had been reached) and at that time the interrupt source register is updated along with any associated status bits.
5	TWIRSTART	Repeat START. 0 = Transfer concludes with a STOP condition 1 = Issue a repeat START condition at the conclusion of the current transfer (DCNT = 0) and begin the next transfer. The current transfer is concluded with updates to the appropriate status and interrupt bits. If errors occurred during the previous transfer, a repeat START does not occur. In the absence of any errors, master enable (MEN) does not clear itself on a repeat start.
13–6	TWIDCNT	Data Transfer Count. Indicates the number of data bytes to transfer. As each data word is transferred, the data transfer count is decremented. When DCNT is zero, a STOP (or restart condition) is issued. Setting DCNT to 0xFF disables the counter. In this transfer mode, data continues to be transferred until it is concluded by setting the STOP bit.
14	TWISDAOVR	Serial Data (TWI_DATA) Override. For use when direct control of the Serial Data line is required. Normal master and slave mode operation should not require override operation. 0 = Normal serial data operation under the control of the transmit shift register and acknowledge logic 1 = Serial data output is driven to an active “zero” level, overriding all other logic. This state is held until the bit location is cleared.
15	TWISCLOVR	Serial Clock (TWI_Clock) Override. For use when direct control of the serial clock line is required. Normal master and slave mode operation should not require override operation. 0 = Normal serial clock operation under the control of master mode clock generation and slave mode clock stretching logic 1 = Serial clock output is driven to an active “zero” level, overriding all other logic. This state is held until the bit location is cleared.

Master Address Register (TWIMADDR)

During the addressing phase of a transfer, the TWI controller, with its master enabled, transmits the contents of the TWI master mode address register (TWIMADDR, shown in [Figure A-102](#)). When programming this register, omit the read/write bit. That is, only the upper 7 bits that make up the slave address should be written to this register. For example, if the slave address is 1010000X, then TWIMADDR is programmed with 1010000, which corresponds to 0x50. When sending out the address on the bus, the TWI controller appends the read/write bit as appropriate, based on the state of the MDIR bit in the master mode control register.

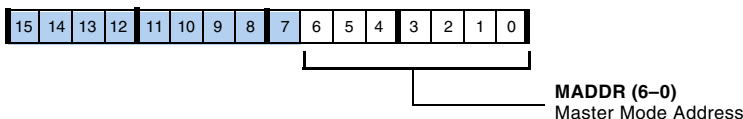

Figure A-102. TWIMADDR Register (RW)

Master Mode Status Register (TWIMSTAT)

The TWI master mode status register (TWIMSTAT, shown in [Figure A-103](#) and described in [Table A-78](#)) holds information during master mode transfers and at their conclusions. Generally, master mode status bits are not directly associated with the generation of interrupts but offer information on the current transfer. Slave mode operation does not affect master mode status bits.

Peripherals Routed Through the DPI

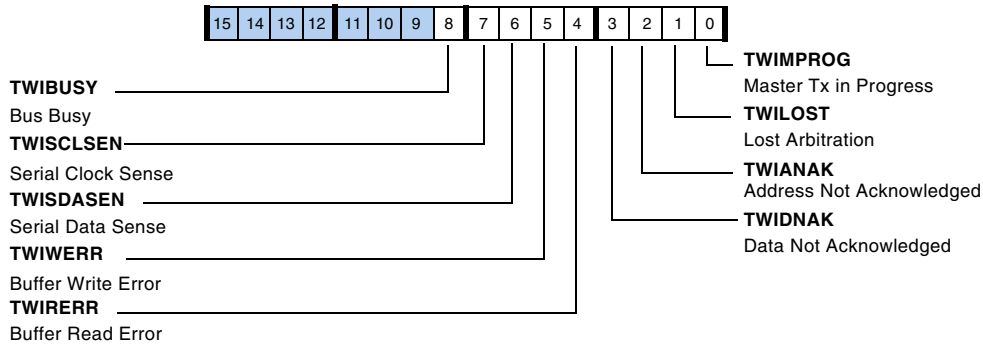

Figure A-103. TWIMSTAT Register

Table A-78. TWIMSTAT Register Bit Descriptions (RO)

Bit	Name	Description
0	TWIMPROG	Master Transfer In Progress. 0 = Currently no transfer is taking place. This can occur once a transfer is complete or while an enabled master is waiting for an idle bus. 1 = A master transfer is in progress.
1 (W1C)	TWILOST	Lost Arbitration. 0 = The current transfer has not lost arbitration with another master. 1 = The current transfer was aborted due to the loss of arbitration with another master.
2 (W1C)	TWIANAK	Address Not Acknowledged. 0 = The current master transfer has not detected a NAK during addressing. 1 = The current master transfer was aborted due to the detection of a NAK during the address phase of the transfer.
3 (W1C)	TWIDNAK	Data Not Acknowledged. 0 = The current master transfer has not detected a NAK during data transmission. 1 = The current master transfer was aborted due to the detection of a NAK during data transmission.

Table A-78. TWIMSTAT Register Bit Descriptions (RO) (Cont'd)

Bit	Name	Description
4 (W1C)	TWIRERR	<p>Buffer Read Error.</p> <p>0 = The current master transmit has not detected a buffer read error.</p> <p>1 = The current master transfer was aborted due to a transmit buffer read error. At the time data was required by the transmit shift register, the buffer was empty.</p>
5 (W1C)	TWIWERR	<p>Buffer Write Error.</p> <p>0 = The current master receive has not detected a receive buffer write error.</p> <p>1 = The current master transfer was aborted due to a receive buffer write error. The receive buffer and receive shift register were both full at the same time.</p>
6	TWISDASEN	<p>Serial Data Sense. For use when direct sensing of the serial data line is required. The register value is delayed due to the input filter (nominally 50 ns). Normal master and slave mode operation should not require this feature.</p> <p>0 = An inactive “one” is currently being sensed on serial data line.</p> <p>1 = An active “zero” is currently being sensed on serial data line. The source of the active driver is not known and can be internal or external.</p>

Peripherals Routed Through the DPI

Table A-78. TWIMSTAT Register Bit Descriptions (RO) (Cont'd)

Bit	Name	Description
7	TWISCLSEN	Serial Clock Sense. For use when direct sensing of the serial clock line is required. The register value is delayed due to the input filter (nominally 50 ns). Normal master and slave mode operation should not require this feature. 0 = An inactive “one” is currently being sensed on TWI_CLK. 1 = An active “zero” is currently being sensed on TWI_CLK. The source of the active driver is not known and can be internal or external.
8	TWIBUSY	Bus Busy. Indicates whether the bus is currently busy or free. This indication applies to all devices. Upon a START condition, setting the register value is delayed due to the input filtering. Upon a STOP condition, clearing the register value occurs after time t_{BUF} . 0 = The bus is free. The clock and data bus signals have been inactive for the appropriate bus free time. 1 = The bus is busy. Clock and/or data activity has been detected.

FIFO Control Register (TWIFIFOCTL)

The TWI FIFO control register (TWIFIFOCTL, shown in [Figure A-104](#) and described in [Table A-79](#)) affects only the FIFO and is not tied in any way with master or slave mode operation.

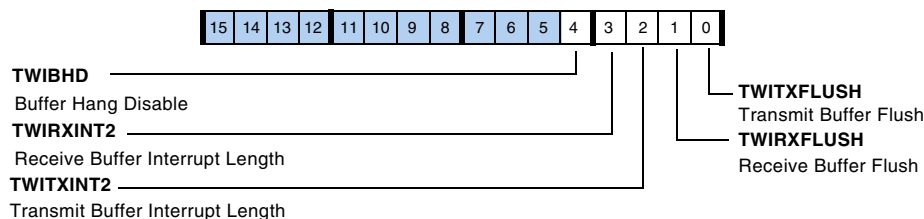

Figure A-104. TWIFIFOCTL Register

Table A-79. TWIFIFOCTL Register Bit Descriptions (RW)

Bit	Name	Description
0	TWITXFLUSH	Transmit Buffer Flush. 0 = Normal operation of the transmit buffer and its status bits 1 = Flush the contents of the transmit buffer and update the status to indicate the buffer is empty. This state is held until this bit is cleared. During an active transmit, the transmit buffer in this state responds as if the transmit buffer is empty.
1	TWIRXFLUSH	Receive Buffer Flush. 0 = Normal operation of the receive buffer and its status bits. 1 = Flush the contents of the receive buffer and update the status to indicate the buffer is empty. This state is held until this bit is cleared. During an active receive the receive buffer in this state responds to the receive logic as if it is full.
2	TWITXINT2	Transmit Buffer Interrupt Length. Determines the rate at which transmit buffer interrupts are generated. Interrupts may be generated with each byte transmitted or after two bytes are transmitted. 0 = An interrupt (TWITXINT) is set when TWITXS indicates one or two bytes in the FIFO are empty (01 or 00). 1 = An interrupt (TWITXINT) is set when TWITXS indicates two bytes in the FIFO are empty (00).
3	TWIRXINT2	Receive Buffer Interrupt Length. Determines the rate at which receive buffer interrupts are generated. Interrupts may be generated with each byte received or after two bytes are received. 0 = An interrupt (TWIRXINT) is set when TWIRXS indicates one or two bytes in the FIFO are full (01 or 11). 1 = An interrupt (TWIRXINT) is set when TWIRXS indicates two bytes in the FIFO are full (11).
4	TWIBHD	Receive Buffer Hang Disable. 0 = Read of FIFO happens only when Rx FIFO has a valid byte. Write of FIFO happens only when Tx FIFO has at least one empty space. 1 = Read/write happens irrespective of FIFO status

FIFO Status Register (TWIFFOSTAT)

The fields in the TWI FIFO status register (TWIFFOSTAT, shown in [Figure A-105](#) and described in [Table A-80](#)) indicate the state of the FIFO

Peripherals Routed Through the DPI

buffers' receive and transmit contents. The FIFO buffers do not discriminate between master data and slave data. By using the status and control bits provided, the FIFO can be managed to allow simultaneous master and slave operation.

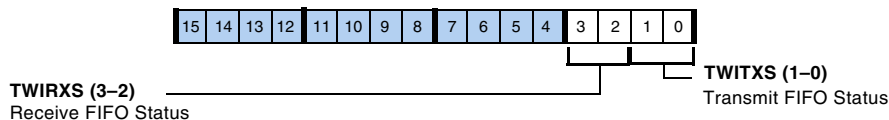

Figure A-105. TWIFIFOSTAT Register

Table A-80. TWIFIFOSTAT Register Bit Descriptions (RO)

Bit	Name	Description
1-0	TWITXS	<p>Transfer FIFO Status. Indicate the number of valid data bytes in the FIFO buffer. The status is updated with each FIFO buffer write using the peripheral data bus or read access by the transmit shift register. Simultaneous accesses are allowed.</p> <p>00 = FIFO is empty. Either a single- or double-byte peripheral write of the FIFO goes through immediately.</p> <p>01 = FIFO contains one byte of data. A single byte peripheral write of the FIFO goes through immediately. A double-byte peripheral write waits until the FIFO is empty</p> <p>11 = FIFO is full and contains two bytes of data.</p> <p>10 = Illegal</p>
3-2	TWIRXS	<p>Receive FIFO Status. Indicate the number of valid data bytes in the receive FIFO buffer. The status is updated with each FIFO buffer read using the peripheral data bus or write access by the receive shift register. Simultaneous accesses are allowed.</p> <p>00 = FIFO is empty</p> <p>01 = FIFO contains one byte of data. A single-byte peripheral read of the FIFO goes through immediately. A double-byte peripheral read waits until the FIFO is full.</p> <p>11 = FIFO is full and contains two bytes of data. Either a single- or double-byte peripheral read of the FIFO is allowed.</p> <p>10 = Illegal</p>

Interrupt Latch Register (TWIIRPTL)

The TWI interrupt source latch register (TWIIRPTL, shown in [Figure A-106](#) and described in [Table A-81](#)) contains information about functional areas requiring servicing. Many of the bits serve as an indicator to further read and service various status registers. After servicing the interrupt source associated with a bit, the user must clear that interrupt by writing a one (W1C).

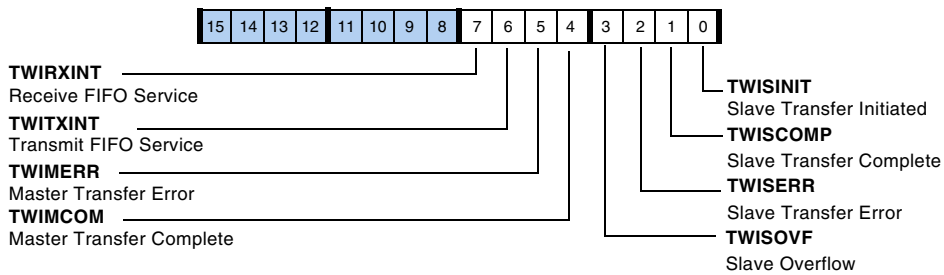

Figure A-106. TWIIRPTL Register

Table A-81. TWIIRPTL Register Bit Descriptions (W1C)

Bit	Name	Description
0	TWISINIT	Slave Transfer Initiated. 0 = A transfer is not in progress. An address match has not occurred since the last time this bit was cleared. 1 = The slave has detected an address match and a transfer has been initiated.
1	TWISCOMP	Slave Transfer Complete. 0 = The completion of a transfer not detected 1 = The transfer is complete and either a stop, or a restart was detected.
2	TWISERR	Slave Transfer Error. 0 = No errors detected. 1 = An error has occurred. A restart or stop condition has occurred during the data receive phase of a transfer.

Peripherals Routed Through the DPI

Table A-81. TWIIRPTL Register Bit Descriptions (W1C) (Cont'd)

Bit	Name	Description
3	TWISOVF	Slave Over Flow. 0 = No overflow detected. 1 = The slave transfer complete (TWISCOMP) was set at the time a subsequent transfer has acknowledged an address phase. The transfer continues, however, it may be difficult to delineate data of one transfer from another.
4	TWIMCOM	Master Transfer Complete. 0 = The completion of a transfer not detected. 1 = The initiated master transfer is complete. In the absence of a repeat start, the bus is released.
5	TWIMERR	Master Transfer Error. 0 = No errors detected. 1 = A master error occurred. The conditions surrounding the error are indicated by the master status register (TWIMSTAT).
6	TWITXINT	Transmit FIFO Service. 0 = No errors detected. 1 = The transmit FIFO buffer has one or two 8-bit locations available to be written. If TWITXINT2 is 0, this bit is set each time TWITXS is updated to either 01 or 00. If TWITXINT2 is 1, this bit is set each time TWITXS is updated to 00.
7	TWIRXINT	Receive FIFO Service. 0 = No errors detected. 1 = The receive FIFO buffer has one or two 8-bit locations containing data to be read. If TWIRXINT2 is 0, this bit is set each time TWIRXS is updated to either 01 or 11. If TWIRXINT2 is 1, this bit is set each time TWIRXS is updated to 11.

Interrupt Mask Register (TWIIMASK)

The TWI interrupt mask register (TWIIMASK, shown in [Figure A-107](#) and described in [Table A-82](#)) enables interrupt sources to assert the interrupt output. Each enable bit corresponds with one interrupt latch bit in the

TWI interrupt latch register (TWIIRPTL). Reading and writing the TWIIMASK register does not affect the contents of the TWIIRPTL register.

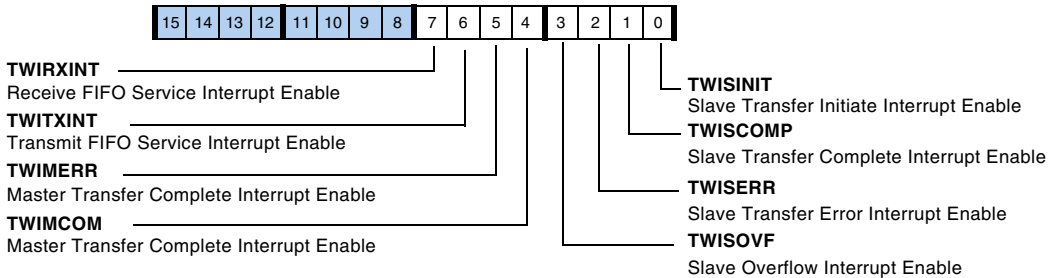

Figure A-107. TWIIMASK Register

Table A-82. TWIIMASK Register Bit Descriptions (RW)

Bit	Name	Description
0	TWISINIT	Slave Transfer Initiate Interrupt Enable. 0 = The corresponding interrupt source is prevented from asserting the interrupt output 1 = The corresponding interrupt source asserts the interrupt output
1	TWISCOMP	Slave Transfer Complete Interrupt. 0 = The corresponding interrupt source is prevented from asserting the interrupt output 1 = The corresponding interrupt source asserts the interrupt output
2	TWISERR	Slave Transfer Error Interrupt. 0 = The corresponding interrupt source is prevented from asserting the interrupt output 1 = The corresponding interrupt source asserts the interrupt output
3	TWISOVF	Slave Over Flow Interrupt Enable. 0 = The corresponding interrupt source is prevented from asserting the interrupt output 1 = The corresponding interrupt source asserts the interrupt output
4	TWIMCOM	Master Transfer Complete Interrupt Enable. 0 = The corresponding interrupt source is prevented from asserting the interrupt output 1 = The corresponding interrupt source asserts the interrupt output

Peripherals Routed Through the DPI

Table A-82. TWIIMASK Register Bit Descriptions (RW) (Cont'd)

Bit	Name	Description
5	TWIMERR	Master Transfer Error Interrupt Enable. 0 = The corresponding interrupt source is prevented from asserting the interrupt output 1 = The corresponding interrupt source asserts the interrupt output
6	TWITXINT	Transmit FIFO Service Interrupt Enable. 0 = The corresponding interrupt source is prevented from asserting the interrupt output 1 = The corresponding interrupt source asserts the interrupt output
7	TWIRXINT	Receive FIFO Service Interrupt Enable. 0 = The corresponding interrupt source is prevented from asserting the interrupt output 1 = The corresponding interrupt source asserts the interrupt output.

Peripheral Timer Registers

The timer peripheral module provides general-purpose timer functionality. It consists of three identical timer units. Each timer has memory-mapped registers. They are described in the following sections.

Read-Modify-Write Timer Control Register

For the Timer global control register, the traditional read-modify-write operations to disable a timer have changed. The action is to directly write which simplifies timer enable/disable and can be accomplished with fewer instructions. Example:

Instead of:

```
ustat3=dm(TMCTL);          /* Timer Control Register */  
bit set ustat3 TIM1DIS;    /* disables timer 1 */  
dm(TMCTL)=ustat3;
```

Use:

```

ustat3 = TIM1DIS;
dm(TMCTL)=ustat3;

```

Writes to the enable and disable bit-pair for a timer works as follows.

TIMxDIS = 0, TIMxEN = 0 – No action
 TIMxDIS = 0, TIMxEN = 1 – Enable the timer
 TIMxDIS = 1, TIMxEN = x – Disable the timer

For reads, the interpretation is as follows.

TIM1DIS = 0, TIMxEN = 0 – Timer is disabled
 TIM1DIS = 1, TIMxEN = 1 – Timer is enabled

Any other read combination is not possible. Read of the TMCTL register returns the enable status on both the enable and disable bits.

Control Registers (TMxCTL)

All timer clocks are gated off when the specific timer’s configuration register is set to zero at system reset or subsequently reset by user programs. These registers are shown in [Figure A-108](#).

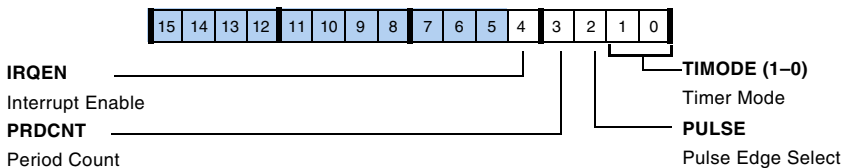

Figure A-108. TMxCTL Register

Peripherals Routed Through the DPI

Table A-83. TMxCTL Register Bit Descriptions (RW)

Bit	Name	Definition
1–0	TIMODE	Timer Mode. 00 = Reset 01 = PWM_OUT mode (TIMODEPWM) 10 = WIDTH_CAP mode (TIMODEW) 11 = EXT_CLK mode (TIMODEEXT)
2	PULSE	Pulse Edge Select. 1 = Positive active pulse 0 = Negative active pulse
3	PRDCNT	Period Count. 1 = Count to end of period 0 = Count to end of width
4	IRQEN	Interrupt Enable. 1 = Enable 0 = Disable

Status Registers (TMxSTAT)

The status registers `TMxSTAT` are shown in [Figure A-109](#). Each timer generates a unique processor interrupt request signal, `TIMxIRQ`.

A common status register latches these interrupts. Interrupt bits are sticky and must be cleared to assure that the interrupt is not reissued.

Each timer is provided with its own sticky status register `TIMxEN` bit. To enable or disable an individual timer, the `TIMxEN` bit is set or cleared. For example, writing a one to bit 8 sets the `TIMOEN` bit; writing a one to bit 9 clears it. Writing a one to both bit 8 and bit 9 clears `TIMOEN`. Reading the status register returns the `TIMOEN` state on both bit 8 and bit 9. The remaining `TIMxEN` bits operate similarly.

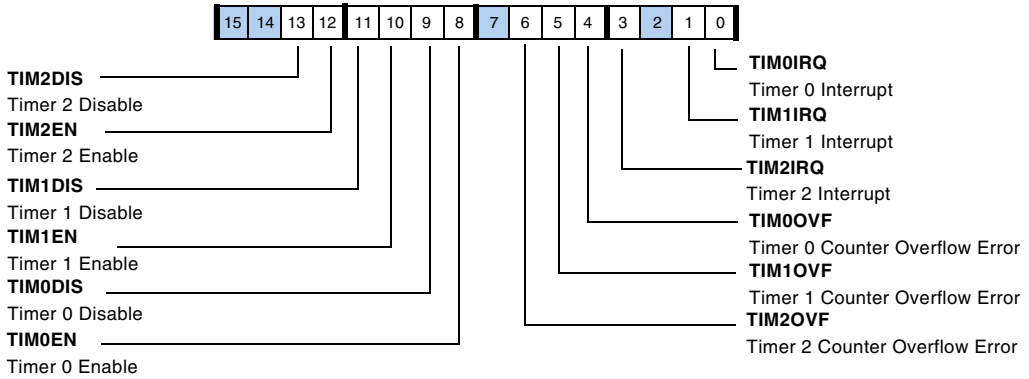

Figure A-109. TMxSTAT Register

Table A-84. TMxSTAT Register Bit Descriptions (RW)

Bit	Name	Description
0 (W1C)	TIM0IRQ Timer 0 Interrupt Latch	Also an output
1 (W1C)	TIM1IRQ Timer 1 Interrupt Latch	Also an output
2	Reserved	
3 (W1C)	TIM2IRQ Timer 2 Interrupt Latch	Also an output
4 (RO)	TIM0OVF Timer 0 Overflow/Error	Also an output
5 (RO)	TIM1OVF Timer 1 Overflow/Error	Also an output
6 (RO)	TIM2OVF Timer 2 Overflow/Error	Also an output
7	Reserved	
8	TIM0EN Timer 0 Enable	Enable timer 0
9 (W1C)	TIM0DIS Timer 0 Disable	Disable timer 0
10	TIM1EN Timer 1 Enable	Enable timer 1
11 (W1C)	TIM1DIS Timer 1 Disable	Disable timer 1
12	TIM2EN Timer 2 Enable	Enable timer 2
13 (W1C)	TIM2DIS Timer 2 Disable	Disable timer 2
31-11	Reserved	

Register Listing

Register Listing

This section list all available memory mapped IOP registers including the address and reset values.

Register Mnemonic	Address	Description	Reset (Valid Bits)
Power Management Register			
PMCTL	0x2000	Power management control	Hardware dependent
Misc. Registers			
RUNRSTCTL	0x2100	Running Reset Control (ADSP-2137x only)	0x0
ROMID	0x20FF	ROM Identification	Hardware dependent
Global External Port Register			
EPCTL	0x1801	External Port Global Control	0xF0
Asynchronous Memory Interface Registers			
AMICTL0	0x1804	AMI Control Register for Bank 1	0x0
AMICTL1	0x1805	AMI Control Register for Bank 2	0x0
AMICTL2	0x1806	AMI Control Register for Bank 3	0x0
AMICTL3	0x1807	AMI Control Register for Bank 4	0x0
AMISTAT	0x180A	AMI Status	0x1
SDRAM Registers			
SDCTL	0x1800	SDRAM Control	0x0
SDRRC	0x1802	AMI SDRAM refresh count	0x0
SDSTAT	0x1803	AMI Control Register for Bank 3	0x0
Shared Memory Interface Registers (ADSP-21368 only)			
BMAX	0x180D	Bus Timeout Max	0x0
BCNT	0x180E	Bus Timeout Current	0x0
SYSTAT	0x180F	Shared Memory Status	0x0

Registers Reference

Register Mnemonic	Address	Description	Reset (Valid Bits)
DMA Address Registers			
DMAC0	0x180B	External Port DMA CH 0 Control	0x0
EIEP0	0x1820	External Port CH 0 DMA external index address	0x0
EMEP0	0x1821	External Port CH 0 DMA external modifier	0x0
ECEP0	0x1822	External Port CH 0 DMA external count	0x0
IIEP0	0x1823	External Port CH 0 DMA internal index address	0x0
IMEP0	0x1824	External Port CH 0 DMA internal modifier	0x0
ICEP0	0x1825	External Port CH 0 DMA internal count	0x0
CPEP0	0x1826	External Port CH 0 DMA chain pointer	0x0
EBEP0	0x1827	External Port CH 0 DMA external base address	0x0
TPEP0	0x1828	External Port CH 0 DMA TAP pointer	0x0
ELEP0	0x1829	External Port CH 0 DMA external length	0x0
EPTC0	0x182B	External Port CH 0 DMA delay line TAP count	0x0
DMAC1	0x180C	External Port DMA CH 1 control	0x0
EIEP1	0x1830	External Port CH 1 DMA external index address	0x0
EMEP1	0x1831	External Port CH 1 DMA external modifier	0x0
ECEP1	0x1832	External Port CH 1 DMA external count	0x0
IIEP1	0x1833	External Port CH 1 DMA internal index address	0x0
IMEP1	0x1834	External Port CH 1 DMA internal modifier	0x0
ICEP1	0x1835	External Port CH 1 DMA internal count	0x0
CPEP1	0x1836	External Port CH 1 DMA chain pointer	0x0
EBEP1	0x1837	External Port CH 1 DMA external base address	0x0
ELEP1	0x1839	External Port CH 1 DMA external length	0x0
EPTC1	0x183B	External Port CH 1 DMA delay line TAP count	0x0

Register Listing

Register Mnemonic	Address	Description	Reset (Valid Bits)
Global Serial Port Register			
SPERRSTAT	0x2300	Global SPORT Error Status	0x0
Serial Port Error Control Registers			
SPERRCTL0	0xC18	SPORT0 Error Control	0x0
SPERRCTL1	0xC19	SPORT1 Error Control	0x0
SPERRCTL2	0x418	SPORT2 Error Control	0x0
SPERRCTL3	0x419	SPORT3 Error Control	0x0
SPERRCTL4	0x818	SPORT4 Error Control	0x0
SPERRCTL5	0x819	SPORT5 Error Control	0x0
SPERRCTL6	0x4818	SPORT6 Error Control	0x0
SPERRCTL7	0x4819	SPORT7 Error Control	0x0
Serial Port 0 and 1 Registers			
SPCTL0	0xC00	SPORT 0 Control Register	0x0000 0000
SPCTL1	0xC01	SPORT 1 Control Register	0x0000 0000
DIV0	0xC02	SPORT 0 divisor for TX/RX SCLK0 and FS0	0x0
DIV1	0xC03	SPORT 1 divisor for TX/RX SCLK1 and FS1	0x0
SPMCTL0	0xC04	SPORT 0 TDM Control Register	0x0
SPMCTL1	0xC17	SPORT 1 TDM Control Register	0x0
MT0CS0	0xC05	SPORT 0 TDM TX select, CH31–0	0x0
MT0CS1	0xC06	SPORT 0 TDM TX select, CH63–32	0x0
MT0CS2	0xC07	SPORT 0 TDM TX select, CH95–64	0x0
MT0CS3	0xC08	SPORT 0 TDM TX select, CH127–96	0x0
MR1CS0	0xC09	SPORT 1 TDM RX select, CH31–0	0x0
MR1CS1	0xC0A	SPORT 1 TDM RX select, CH63–32	0x0
MR1CS2	0xC0B	SPORT 1 TDM RX select, CH95–64	0x0
MR1CS3	0xC0C	SPORT 1 TDM RX select, CH127–96	0x0

Registers Reference

Register Mnemonic	Address	Description	Reset (Valid Bits)
MT0CCS0	0xC0D	SPORT 0 TDM TX compand select, CH31–0	0x0
MT0CCS1	0xC0E	SPORT 0 TDM TX compand select, CH63–32	0x0
MT0CCS2	0xC0F	SPORT 0 TDM TX compand select, CH95–64	0x0
MT0CCS3	0xC10	SPORT 0 TDM TX compand select, CH127–96	0x0
MR1CCS0	0xC11	SPORT 1 TDM RX compand select, CH31–0	0x0
MR1CCS1	0xC12	SPORT 1 TDM RX compand select, CH63–32	0x0
MR1CCS2	0xC13	SPORT 1 TDM RX compand select, CH95–64	0x0
MR1CCS3	0xC14	SPORT 1 TDM RX compand select, CH127–96	0x0
IISP0A	0xC40	Internal memory DMA address	0x0
IMSP0A	0xC41	Internal memory DMA access modifier	0x0
CSP0A	0xC42	Contains number of DMA transfers remaining	0x0
CPSP0A	0xC43	Points to next DMA parameters	0x0
IISP0B	0xC44	Internal memory DMA address	0x0
IMSP0B	0xC45	Internal memory DMA access modifier	0x0
CSP0B	0xC46	Contains number of DMA transfers remaining	0x0
CPSP0B	0xC47	Points to next DMA parameters	0x0
IISP1A	0xC48	Internal memory DMA address	0x0
IMSP1A	0xC49	Internal memory DMA access modifier	0x0
CSP1A	0xC4A	Contains number of DMA transfers remaining	0x0
CPSP1A	0xC4B	Points to next DMA parameters	0x0
IISP1B	0xC4C	Internal memory DMA address	0x0
IMSP1B	0xC4D	Internal memory DMA access modifier	0x0
CSP1B	0xC4E	Contains number of DMA transfers remaining	0x0
CPSP1B	0xC4F	Points to next DMA parameters	0x0
TXSP0A	0xC60	SPORT 0A transmit data	0x0

Register Listing

Register Mnemonic	Address	Description	Reset (Valid Bits)
RXSP0A	0xC61	SPORT 0A receive data	0x0
TXSP0B	0xC62	SPORT 0B transmit data	0x0
RXSP0B	0xC63	SPORT 0B receive data	0x0
TXSP1A	0xC64	SPORT 1A transmit data	0x0
RXSP1A	0xC65	SPORT 1A receive data	0x0
TXSP1B	0xC66	SPORT 1B transmit data	0x0
RXSP1B	0xC67	SPORT 1B receive data	0x0
Serial Port 2 and 3 Registers			
SPCTL2	0x400	SPORT 2 control	0x0000 0000
SPCTL3	0x401	SPORT 3 control	0x0000 0000
DIV2	0x402	SPORT 2 divisor for TX/RX SCLK2 and FS2	0x0
DIV3	0x403	SPORT 3 divisor for TX/RX SCLK3 and FS3	0x0
SPMCTL2	0x404	SPORTs 2 TDM control	0x0
MT2CS0	0x405	SPORT 2 TDM TX select, CH31–0	0x0
MT2CS1	0x406	SPORT 2 TDM TX select, CH63–32	0x0
MT2CS2	0x407	SPORT 2 TDM TX select, CH95–64	0x0
MT2CS3	0x408	SPORT 2 TDM TX select, CH127–96	0x0
MR3CS0	0x409	SPORT 3 TDM RX select, CH31–0	0x0
MR3CS1	0x40A	SPORT 3 TDM RX select, CH63–32	0x0
MR3CS2	0x40B	SPORT 3 TDM RX select, CH95–64	0x0
MR3CS3	0x40C	SPORT 3 TDM RX select, CH127–96	0x0
MT2CCS0	0x40D	SPORT 2 TDM TX compand select, CH31–0	0x0
MT2CCS1	0x40E	SPORT 2 TDM TX compand select, CH63–32	0x0
MT2CCS2	0x40F	SPORT 2 TDM TX compand select, CH95–64	0x0
MT2CCS3	0x410	SPORT 2 TDM TX compand select, CH127–96	0x0
MR3CCS0	0x411	SPORT 3 TDM RX compand select, CH31–0	0x0

Registers Reference

Register Mnemonic	Address	Description	Reset (Valid Bits)
MR3CCS1	0x412	SPORT 3 TDM RX compand select, CH63–32	0x0
MR3CCS2	0x413	SPORT 3 TDM RX compand select, CH95–64	0x0
MR3CCS3	0x414	SPORT 3 TDM RX compand select, CH127–96	0x0
SPMCTL3	0x417	SPORT 3 TDM Control	0x0
IISP2A	0x440	Internal memory DMA address	0x0
IMSP2A	0x441	Internal memory DMA access modifier	0x0
CSP2A	0x442	Contains number of DMA transfers remaining	0x0
CPSP2A	0x443	Points to next DMA parameters	0x0
IISP2B	0x444	Internal memory DMA address	0x0
IMSP2B	0x445	Internal memory DMA access modifier	0x0
CSP2B	0x446	Contains number of DMA transfers remaining	0x0
CPSP2B	0x447	Points to next DMA parameters	0x0
IISP3A	0x448	Internal memory DMA address	0x0
IMSP3A	0x449	Internal memory DMA access modifier	0x0
CSP3A	0x44A	Contains number of DMA transfers remaining	0x0
CPSP3A	0x44B	Points to next DMA parameters	0x0
IISP3B	0x44C	Internal memory DMA address	0x0
IMSP3B	0x44D	Internal memory DMA access modifier	0x0
CSP3B	0x44E	Contains number of DMA transfers remaining	0x0
CPSP3B	0x44F	Points to next DMA parameters	0x0
TXSP2A	0x460	SPORT 2A transmit data	0x0
RXSP2A	0x461	SPORT 2A receive data	0x0
TXSP2B	0x462	SPORT 2B transmit data	0x0
RXSP2B	0x463	SPORT 2B receive data	0x0
TXSP3A	0x464	SPORT 3A transmit data	0x0
RXSP3A	0x465	SPORT 3A receive data	0x0

Register Listing

Register Mnemonic	Address	Description	Reset (Valid Bits)
TXSP3B	0x466	SPORT 3B transmit data	0x0
RXSP3B	0x467	SPORT 3B receive data	0x0
Serial Port 4 and 5 Registers			
SPCTL4	0x800	SPORT 4 control	0x0000 0000
SPCTL5	0x801	SPORT 5 control	0x0000 0000
DIV4	0x802	SPORT 4 divisor for TX/RX SCLK4 and FS4	0x0
DIV5	0x803	SPORT 5 divisor for TX/RX SCLK5 and FS5	0x0
SPMCTL4	0x804	SPORT 4 TDM Control	0x0
MT4CS0	0x805	SPORT 4 TDM TX select, CH31–0	0x0
MT4CS1	0x806	SPORT 4 TDM TX select, CH63–32	0x0
MT4CS2	0x807	SPORT 4 TDM TX select, CH95–64	0x0
MT4CS3	0x808	SPORT 4 TDM TX select, CH127–96	0x0
MR5CS0	0x809	SPORT 5 TDM RX select, CH31–0	0x0
MR5CS1	0x80A	SPORT 5 TDM RX select, CH63–32	0x0
MR5CS2	0x80B	SPORT 5 TDM RX select, CH95–64	0x0
MR5CS3	0x80C	SPORT 5 TDM RX select, CH127–96	0x0
MT4CCS0	0x80D	SPORT 4 TDM TX compand select, CH31–0	0x0
MT4CCS1	0x80E	SPORT 4 TDM TX compand select, CH63–32	0x0
MT4CCS2	0x80F	SPORT 4 TDM TX compand select, CH95–64	0x0
MT4CCS3	0x810	SPORT 4 TDM TX compand select, CH127–96	0x0
MR5CCS0	0x811	SPORT 5 TDM RX compand select, CH31–0	0x0
MR5CCS1	0x812	SPORT 5 TDM RX compand select, CH63–32	0x0
MR5CCS2	0x813	SPORT 5 TDM RX compand select, CH95–64	0x0
MR5CCS3	0x814	SPORT 5 TDM RX compand select, CH127–96	0x0
SPMCTL5	0x817	SPORT 5 TDM Control	0x0

Registers Reference

Register Mnemonic	Address	Description	Reset (Valid Bits)
IISP4A	0x840	Internal memory DMA address	0x0
IMSP4A	0x841	Internal memory DMA access modifier	0x0
CSP4A	0x842	Contains number of DMA transfers remaining	0x0
CPSP4A	0x843	Points to next DMA parameters	0x0
IISP4B	0x844	Internal memory DMA address	0x0
IMSP4B	0x845	Internal memory DMA access modifier	0x0
CSP4B	0x846	Contains number of DMA transfers remaining	0x0
CPSP4B	0x847	Points to next DMA parameters	0x0
IISP5A	0x848	Internal memory DMA address	0x0
IMSP5A	0x849	Internal memory DMA access modifier	0x0
CSP5A	0x84A	Contains number of DMA transfers remaining	0x0
CPSP5A	0x84B	Points to next DMA parameters	0x0
IISP5B	0x84C	Internal memory DMA address	0x0
IMSP5B	0x84D	Internal memory DMA access modifier	0x0
CSP5B	0x84E	Contains number of DMA transfers remaining	0x0
CPSP5B	0x84F	Points to next DMA parameters	0x0
TXSP4A	0x860	SPORT 4A transmit data	0x0
RXSP4A	0x861	SPORT 4A receive data	0x0
TXSP4B	0x862	SPORT 4B transmit data	0x0
RXSP4B	0x863	SPORT 4B receive data	0x0
TXSP5A	0x864	SPORT 5A transmit data	0x0
RXSP5A	0x865	SPORT 5A receive data	0x0
TXSP5B	0x866	SPORT 5B transmit data	0x0
RXSP5B	0x867	SPORT 5B receive data	0x0

Register Listing

Register Mnemonic	Address	Description	Reset (Valid Bits)
SPORT 6 and 7 Registers			
SPCTL6	0x4800	SPORT 6 control	0x0000 0000
SPCTL7	0x4801	SPORT 7 control	0x0000 0000
DIV6	0x4802	SPORT 6 divisor for TX/RX SCLK6 and FS6	0x0
DIV7	0x4803	SPORT 7 divisor for TX/RX SCLK7 and FS7	0x0
SPMCTL6	0x4804	SPORT 6 TDM Control	0x0
MT6CS0	0x4807	SPORT 6 TDM TX select, CH31–0	0x0
MT6CS1	0x4806	SPORT 6 TDM TX select, CH63–32	0x0
MT6CS2	0x4807	SPORT 6 TDM TX select, CH95–64	0x0
MT6CS3	0x4808	SPORT 6 TDM TX select, CH127–96	0x0
MR7CS0	0x4809	SPORT 7 TDM RX select, CH31–0	0x0
MR7CS1	0x480A	SPORT 7 TDM RX select, CH63–32	0x0
MR7CS2	0x480B	SPORT 7 TDM RX select, CH95–64	0x0
MR7CS3	0x480C	SPORT 7 TDM RX select, CH127–96	0x0
MT6CCS0	0x480D	SPORT 6 TDM TX compand select, CH31–0	0x0
MT6CCS1	0x480E	SPORT 6 TDM TX compand select, CH63–32	0x0
MT6CCS2	0x480F	SPORT 6 TDM TX compand select, CH95–64	0x0
MT6CCS3	0x4810	SPORT 6 TDM TX compand select, CH127–96	0x0
MR7CCS0	0x4811	SPORT 7 TDM RX compand select, CH31–0	0x0
MR7CCS1	0x4812	SPORT 7 TDM RX compand select, CH63–32	0x0
MR7CCS2	0x4813	SPORT 7 TDM RX compand select, CH95–64	0x0
MR7CCS3	0x4814	SPORT 7 TDM RX compand select, CH127–96	0x0
SPMCTL7	0x4817	SPORT 7 TDM Control	0x0
IISP6A	0x4840	Internal memory DMA address	0x0
IMSP6A	0x4841	Internal memory DMA access modifier	0x0

Registers Reference

Register Mnemonic	Address	Description	Reset (Valid Bits)
CSP6A	0x4842	Contains number of DMA transfers remaining	0x0
CPSP6A	0x4843	Points to next DMA parameters	0x0
IISP6B	0x4844	Internal memory DMA address	0x0
IMSP6B	0x4845	Internal memory DMA access modifier	0x0
CSP6B	0x4846	Contains number of DMA transfers remaining	0x0
CPSP6B	0x4847	Points to next DMA parameters	0x0
IISP7A	0x4848	Internal memory DMA address	0x0
IMSP7A	0x4849	Internal memory DMA access modifier	0x0
CSP7A	0x44A	Contains number of DMA transfers remaining	0x0
CPSP7A	0x484B	Points to next DMA parameters	0x0
IISP7B	0x484C	Internal memory DMA address	0x0
IMSP7B	0x484D	Internal memory DMA access modifier	0x0
CSP7B	0x484E	Contains number of DMA transfers remaining	0x0
CPSP7B	0x484F	Points to next DMA parameters	0x0
TXSP6A	0x4860	SPORT 6A transmit data	0x0
RXSP6A	0x4861	SPORT 6A receive data	0x0
TXSP6B	0x4862	SPORT 6B transmit data	0x0
RXSP6B	0x4863	SPORT 6B receive data	0x0
TXSP7A	0x4864	SPORT 7A transmit data	0x0
RXSP7A	0x4865	SPORT 7A receive data	0x0
TXSP7B	0x4866	SPORT 7B transmit data	0x0
RXSP7B	0x4867	SPORT 7B receive data	0x0
SPI Registers			
SPICTL	0x1000	SPI Control	0x0400
SPIFLG	0x1001	SPI Flag	master boot 0xFE01 slave boot 0x0F80

Register Listing

Register Mnemonic	Address	Description	Reset (Valid Bits)
SPISTAT	0x1002	SPI Status	0x01
TXSPI	0x1003	SPI transmit data	0x0
RXSPI	0x1004	SPI receive data	0x0
SPIBAUD	0x1005	SPI baud setup	0x0
RXSPI_SHADOW	0x1006	SPI receive data shadow	0x0
IISPI	0x1080	Internal memory DMA address	0x0
IMSPI	0x1081	Internal memory DMA access modifier	0x0
CSPI	0x1082	Contains number of DMA transfers remaining	0x0
CPSPI	0x1083	Points to next DMA parameters	0x0
SPIDMAC	0x1084	SPI DMA control	0x0
SPIB Registers			
SPICTLB	0x2800	SPIB Control	0x0400
SPIFLGB	0x2801	SPIB Flag	0x0F00
SPISTATB	0x2802	SPIB Status	0x01
TXSPIB	0x2803	SPIB transmit data	0x0
RXSPIB	0x2804	SPIB receive data	0x0
SPIBAUDB	0x2805	SPIB baud setup	0x0
RXSPIB_SHADOW	0x2806	SPIB receive data shadow	0x0
IISPIB	0x2880	Internal memory DMA address	0x0
IMSPIB	0x2881	Internal memory DMA access modifier	0x0
CSPIB	0x2882	Contains number of DMA transfers remaining	0x0
CPSPIB	0x2883	Points to next DMA parameters	0x0
SPIDMACB	0x2884	SPIB DMA control	0x0
Timer Registers			
TMSTAT	0x1400	GP Timer Status Register. TMxSTAT all address the same register TMSTAT	0x0

Registers Reference

Register Mnemonic	Address	Description	Reset (Valid Bits)
TM0STAT	0x1400	GP Timer 0 Status	0x0
TM0CTL	0x1401	GP Timer 0 Control	0x0
TM0CNT	0x1402	GP Timer 0 Count	0x0
TM0PRD	0x1403	GP Timer 0 Period	0x0
TM0W	0x1404	GP Timer 0 Width	0x0
TM1STAT	0x1408	GP Timer 1 Status	0x0
TM1CTL	0x1409	GP Timer 1 Control	0x0
TM1CNT	0x140A	GP Timer 1 Count	0x0
TM1PRD	0x140B	GP Timer 1 Period	0x0
TM1W	0x140C	GP Timer 1 Width	0x0
TM2STAT	0x1410	GP Timer 2 Status	0x0
TM2CTL	0x1411	GP Timer 2 Control	0x0
TM2CNT	0x1412	GP Timer 2 Count	0x0
TM2PRD	0x1413	GP Timer 2 Period	0x0
TM2W	0x1414	GP Timer 2 Width	0x0
SRU DAI Routing Registers			
SRU_CLK0	0x2430	SRU Clock Control 0	0x2526 30C2
SRU_CLK1	0x2431	SRU Clock Control 1	0x3DEF 7BDE
SRU_CLK2	0x2432	SRU Clock Control 2	0x3DEF 7BDE
SRU_CLK3	0x2433	SRU Clock Control 3	0x3DEF 7BDE
SRU_CLK4	0x2434	SRU Clock Control 4	0x3DEF 7BDE
SRU_CLK5	0x2435	SRU Clock Control 5	0x3DEF 7BDE
SRU_DAT0	0x2440	SRU Data Control 0	0x0814 4040
SRU_DAT1	0x2441	SRU Data Control 1	0x0F38 B289
SRU_DAT2	0x2442	SRU Data Control 2	0x0000 0450
SRU_DAT3	0x2443	SRU Data Control 3	0x0

Register Listing

Register Mnemonic	Address	Description	Reset (Valid Bits)
SRU_DAT4	0x2444	SRU Data Control 4	0x0
SRU_DAT5	0x2445	SRU Data Control 5	0x0
SRU_DAT6	0x2446	SRU Data Control 6	0x00FB EFBE
SRU_FS0	0x2450	SRU FS Control 0	0x2736 B4E3
SRU_FS1	0x2451	SRU FS Control 1	0x3DEF 7BDE
SRU_FS2	0x2452	SRU FS Control 2	0x3DEF 7BDE
SRU_FS3	0x2453	SRU FS Control 3	0x1EF7BDE
SRU_FS4	0x2454	SRU FS Control 4	0x3DE
SRU_PIN0	0x2460	SRU Pin Control 0	0x04C8 0A94
SRU_PIN1	0x2461	SRU Pin Control 1	0x04E8 4B96
SRU_PIN2	0x2462	SRU Pin Control 2	0x0366 8C98
SRU_PIN3	0x2463	SRU Pin Control 3	0x03A7 14A3
SRU_PIN4	0x2464	SRU Pin Control 4	0x0569 4F9E
SRU_EXT_MISCA	0x2470	SRU External Misc. A Control	0x3DEF 7BDE
SRU_EXT_MISCB	0x2471	SRU External Misc. B Control	0x3DEF 7BDE
SRU_PBEN0	0x2478	SRU Pin Enable 0	0x0E24 82CA
SRU_PBEN1	0x2479	SRU Pin Enable 1	0x1348 D30F
SRU_PBEN2	0x247A	SRU Pin Enable 2	0x1A55 45D6
SRU_PBEN3	0x247B	SRU Pin Enable 3	0x1D71 F79B
SRU2 DPI Routing Registers			
SRU2_INPUT0	0x1C00	SRU2 Input Signal Routing 0	0x0002 1462
SRU2_INPUT1	0x1C01	SRU2 Input Signal Routing 1	0x1AC0 2C00
SRU2_INPUT2	0x1C02	SRU2 Input Signal Routing 2	0x0
SRU2_INPUT3	0x1C03	SRU2 Input Signal Routing 3	0x0
SRU2_INPUT4	0x1C04	SRU2 Input Signal Routing 4	0x0
SRU2_INPUT5	0x1C05	SRU2 Input Signal Routing 5	0x0

Registers Reference

Register Mnemonic	Address	Description	Reset (Valid Bits)
SRU2_PIN0	0x1C10	SRU2 Pin Assignment 0	0x1801 7556
SRU2_PIN1	0x1C11	SRU2 Pin Assignment 1	0x004D B699
SRU2_PIN2	0x1C12	SRU2 Pin Assignment 2	0x0045 0000
SRU2_PBEN0	0x1C20	SRU2 Pin Enable 0	0x0D00 C28B
SRU2_PBEN1	0x1C21	SRU2 Pin Enable 1	0x0021 03CE
SRU2_PBEN2	0x1C22	SRU2 Pin Enable 2	0x0018 5964
DAI Interrupt Registers			
DAI_IRPTL_FE	0x2480	DAI Falling Edge Interrupt Mask	0x0
DAI_IRPTL_RE	0x2481	DAI Rising Edge Interrupt Mask	0x0
DAI_IRPTL_PRI	0x2484	DAI Interrupt Priority Mask	0x0
DAI_IMASK_H	0x2488	DAI High Priority Interrupt Latch	0x0
DAI_IMASK_L	0x2489	DAI Low Priority Interrupt Latch	0x0
DAI_IMASK_HS	0x248C	Shadow DAI High Priority Interrupt Latch	0x0
DAI_IMASK_LS	0x248D	Shadow DAI Low Priority Interrupt Latch	0x0
DPI Interrupt Registers			
DPI_PIN_PULLUP	0x1C30	DPI Pin Pull-up control	0x3FFF
DPI_PIN_STAT	0x1C31	DPI Pin Status	0x0000 3FFF
DPI_IRPTL	0x1C32	DPI Interrupt Latch	0x0
DPI_IRPTL_SH	0x1C33	DPI Shadow Interrupt Latch	0x0
DPI_IMASK_FE	0x1C34	DPI Falling Edge Interrupt Mask	0x0
DPI_IMASK_RE	0x1C35	DPI Rising Edge Interrupt Mask	0x0
Input Data Port Registers			
IDP_CTL0	0x24B0	IDP Control 0	0x0
IDP_CTL1	0x24B2	IDP Control 1	0x0000 FFFF
IDP_PP_CTL	0x24B1	Parallel Data Acquisition Port Control Register	0x0
IDP_FIFO	0x24D0	IDP FIFO Packing Mode	0x0

Register Listing

Register Mnemonic	Address	Description	Reset (Valid Bits)
DAI_STAT0	0x24B8	IDP Status	0x0
DAI_STAT1	0x24BA	IDP Status	0x0
Input Data Port DMA Parameter Registers			
IDP_DMA_I0	0x2400	IDP DMA Channel 0 Index	0x0
IDP_DMA_I1	0x2401	IDP DMA Channel 1 Index	0x0
IDP_DMA_I2	0x2402	IDP DMA Channel 2 Index	0x0
IDP_DMA_I3	0x2403	IDP DMA Channel 3 Index	0x0
IDP_DMA_I4	0x2404	IDP DMA Channel 4 Index	0x0
IDP_DMA_I5	0x2405	IDP DMA Channel 5 Index	0x0
IDP_DMA_I6	0x2406	IDP DMA Channel 6 Index	0x0
IDP_DMA_I7	0x2407	IDP DMA Channel 7 Index	0x0
IDP_DMA_I0A	0x2408	IDP DMA Channel 0 Index A for Ping Pong DMA	0x0
IDP_DMA_I1A	0x2409	IDP DMA Channel 1 Index A for Ping Pong DMA	0x0
IDP_DMA_I2A	0x240A	IDP DMA Channel 2 Index A for Ping Pong DMA	0x0
IDP_DMA_I3A	0x240B	IDP DMA Channel 3 Index A for Ping Pong DMA	0x0
IDP_DMA_I4A	0x240C	IDP DMA Channel 4 Index A for Ping Pong DMA	0x0
IDP_DMA_I5A	0x240D	IDP DMA Channel 5 Index A for Ping Pong DMA	0x0
IDP_DMA_I6A	0x240E	IDP DMA Channel 6 Index A for Ping Pong DMA	0x0
IDP_DMA_I7A	0x240F	IDP DMA Channel 7 Index A for Ping Pong DMA	0x0
IDP_DMA_I0B	0x2418	IDP DMA Channel 0 Index B for Ping Pong DMA	0x0

Registers Reference

Register Mnemonic	Address	Description	Reset (Valid Bits)
IDP_DMA_I1B	0x2419	IDP DMA Channel 1 Index B for Ping Pong DMA	0x0
IDP_DMA_I2B	0x241A	IDP DMA Channel 2 Index B for Ping Pong DMA	0x0
IDP_DMA_I3B	0x241B	IDP DMA Channel 3 Index B for Ping Pong DMA	0x0
IDP_DMA_I4B	0x241C	IDP DMA Channel 4 Index B for Ping Pong DMA	0x0
IDP_DMA_I5B	0x241D	IDP DMA Channel 5 Index B for Ping Pong DMA	0x0
IDP_DMA_I6B	0x241E	IDP DMA Channel 6 Index B for Ping Pong DMA	0x0
IDP_DMA_I7B	0x241F	IDP DMA Channel 7 Index B for Ping Pong DMA	0x0
IDP_DMA_M0	0x2410	IDP DMA Channel 0 Modify	0x0
IDP_DMA_M1	0x2411	IDP DMA Channel 1 Modify	0x0
IDP_DMA_M2	0x2412	IDP DMA Channel 2 Modify	0x0
IDP_DMA_M3	0x2413	IDP DMA Channel 3 Modify	0x0
IDP_DMA_M4	0x2414	IDP DMA Channel 4 Modify	0x0
IDP_DMA_M5	0x2415	IDP DMA Channel 5 Modify	0x0
IDP_DMA_M6	0x2416	IDP DMA Channel 6 Modify	0x0
IDP_DMA_M7	0x2417	IDP DMA Channel 7 Modify	0x0
IDP_DMA_C0	0x2420	IDP DMA Channel 0 Count	0x0
IDP_DMA_C1	0x2421	IDP DMA Channel 1 Count	0x0
IDP_DMA_C2	0x2422	IDP DMA Channel 2 Count	0x0
IDP_DMA_C3	0x2423	IDP DMA Channel 3 Count	0x0
IDP_DMA_C4	0x2424	IDP DMA Channel 4 Count	0x0
IDP_DMA_C5	0x2425	IDP DMA Channel 5 Count	0x0
IDP_DMA_C6	0x2426	IDP DMA Channel 6 Count	0x0

Register Listing

Register Mnemonic	Address	Description	Reset (Valid Bits)
IDP_DMA_C7	0x2427	IDP DMA Channel 7 Count	0x0
IDP_DMA_PC0	0x2428	IDP DMA Channel 0 Ping Pong Count	0x0
IDP_DMA_PC1	0x2429	IDP DMA Channel 1 Ping Pong Count	0x0
IDP_DMA_PC2	0x242A	IDP DMA Channel 2 Ping Pong Count	0x0
IDP_DMA_PC3	0x242B	IDP DMA Channel 3 Ping Pong Count	0x0
IDP_DMA_PC4	0x242C	IDP DMA Channel 4 Ping Pong Count	0x0
IDP_DMA_PC5	0x242D	IDP DMA Channel 5 Ping Pong Count	0x0
IDP_DMA_PC6	0x242E	IDP DMA Channel 6 Ping Pong Count	0x0
IDP_DMA_PC7	0x242F	IDP DMA Channel 7 Ping Pong Count	0x0
DAI Status Registers			
DAI_PIN_STAT	0x24B9	DAI Pin Buffer Status	0x000F FFFF
DAI_PIN_PULLUP	0x247D	Programmable pull-up control	0xF FFFF
Precision Clock Generator Registers			
PCG_CTLA0	0x24C0	Precision Clock A Control 0	0x0
PCG_CTLA1	0x24C1	Precision Clock A Control 1	0x0
PCG_CTLB0	0x24C2	Precision Clock B Control 0	0x0
PCG_CTLB1	0x24C3	Precision Clock B Control 1	0x0
PCG_CTLC0	0x24C6	Precision Clock C Control 0	0x0
PCG_CTLC1	0x24C7	Precision Clock C Control 1	0x0
PCG_CTLD0	0x24C8	Precision Clock D Control 0	0x0
PCG_CTLD1	0x24C9	Precision Clock D Control 1	0x0
PCG_PW1	0x24C4	Precision Clock Pulse Width Control 1	0x0
PCG_PW2	0x24CA	Precision Clock Pulse Width Control 2	0x0
PCG_SYNC1	0x24C5	Precision Clock Frame Sync Synchronization 1	0x0
PCG_SYNC2	0x24CB	Precision Clock Frame Sync Synchronization 2	0x0
Programmable Interrupt Priority Control Registers			

Registers Reference

Register Mnemonic	Address	Description	Reset (Valid Bits)
PICR0	0x2200	Programmable Interrupt Priority Control 0	0x0A41 8820
PICR1	0x2201	Programmable Interrupt Priority Control 1	0x16A4 A0E6
PICR2	0x2202	Programmable Interrupt Priority Control 2	0x2307 B9AC
PICR3	0x2203	Programmable Interrupt Priority Control 3	0x0000 0012
Pulse Width Modulation Registers			
PWMGCTL	0x3800	PWM Global Control	0x0
PWMGSTAT	0x3801	PWM Global Status	0x0
PWMCTL0	0x3000	PWM Control 0	0x0
PWMSTAT0	0x3001	PWM Status 0	0x0009
PWMPERIOD0	0x3002	PWM Period 0	0x0
PWMDT0	0x3003	PWM Dead Time 0	0x0
PWMA0	0x3005	PWM Channel A Duty Control 0	0x0
PWMB0	0x3006	PWM Channel B Duty Control 0	0x0
PWMSEG0	0x3008	PWM Output Enable 0	0x0
PWMAL0	0x300A	PWM Channel AL Duty Control 0	0x0
PWMBL0	0x300B	PWM Channel BL Duty Control 0	0x0
PWMDBG0	0x300E	PWM Debug Status 0	0x0
PWMPOL0	0x300F	PWM Output Polarity Select 0	0x00FF
PWMCTL1	0x3010	PWM Control 1	0x0
PWMSTAT1	0x3011	PWM Status 1	0x0009
PWMPERIOD1	0x3012	PWM Period 1	0x0
PWMDT1	0x3013	PWM Dead Time 1	0x0
PWMA1	0x3015	PWM Channel A Duty Control 1	0x0
PWMB1	0x3016	PWM Channel B Duty Control 1	0x0
PWMSEG1	0x3018	PWM Output Enable 1	0x0
PWMAL1	0x301A	PWM Channel AL Duty Control 1	0x0

Register Listing

Register Mnemonic	Address	Description	Reset (Valid Bits)
PWMBL1	0x301B	PWM Channel BL Duty Control 1	0x0
PWMDBG1	0x301E	PWM Debug Status 1	0x0
PWMPOL1	0x301F	PWM Output Polarity Select 1	0x00FF
PWMCTL2	0x3400	PWM Control 2	0x0
PWMSTAT2	0x3401	PWM Status 2	0x0009
PWMPERIOD2	0x3402	PWM Period 2	0x0
PWMDT2	0x3403	PWM Dead Time 2	0x0
PWMA2	0x3405	PWM Channel A Duty Control 2	0x0
PWMB2	0x3406	PWM Channel B Duty Control 2	0x0
PWMSEG2	0x3408	PWM Output Enable 2	0x0
PWMAL2	0x340A	PWM Channel AL Duty Control 2	0x0
PWMBL2	0x340B	PWM Channel BL Duty Control 2	0x0
PWMDBG2	0x340E	PWM Debug Status 2	0x0
PWMPOL2	0x340F	PWM Output Polarity Select 2	0x00FF
PWMCTL3	0x3410	PWM Control 3	0x0
PWMSTAT3	0x3411	PWM Status 3	0x0009
PWMPERIOD3	0x3412	PWM Period 3	0x0
PWMDT3	0x3413	PWM Dead Time 3	0x0
PWMA3	0x3415	PWM Channel A Duty Control 3	0x0
PWMB3	0x3416	PWM Channel B Duty Control 3	0x0
PWMSEG3	0x3418	PWM Output Enable 3	0x0
PWMAL3	0x341A	PWM Channel AL Duty Control 3	0x0
PWMBL3	0x341B	PWM Channel BL Duty Control 3	0x0
PWMDBG3	0x341E	PWM Debug Status 3	0x0
PWMPOL3	0x341F	PWM Output Polarity Select 3	0x00FF

Registers Reference

Register Mnemonic	Address	Description	Reset (Valid Bits)
Memory-to-Memory DMA Registers			
MTMCTL	0x2C01	Memory-to-Memory DMA Control	0x0
IIMTMW	0x2C10	MTM DMA Destination Index	0x0
IIMTMR	0x2C11	MTM DMA Source Index	0x0
IMMTMW	0x2C0E	MTM DMA Destination Modify	0x0
IMMTMR	0x2C0F	MTM DMA Source Modify	0x0
CMTMW	0x2C16	MTM DMA Destination Count	0x0
CMTMR	0x2C17	MTM DMA Source Count	0x0
S/PDIF Transmit Registers			
DITCTL	0x24A0	Digital Interface Transmit Control	0x0
S/PDIF Channel Status Registers			
DITCHANA0	0x24A1	Transmit CH0 Subframe A	0x0
DITCHANA1	0x24D4	Transmit CH1 Subframe A	0x0
DITCHANA2	0x24D5	Transmit CH2 Subframe A	0x0
DITCHANA3	0x24D6	Transmit CH3 Subframe A	0x0
DITCHANA4	0x24D7	Transmit CH4 Subframe A	0x0
DITCHANA5	0x24D8	Transmit CH5 Subframe A	0x0
DITCHANB0	0x24A2	Transmit CH0 Subframe B	0x0
DITCHANB1	0x24DA	Transmit CH1 Subframe B	0x0
DITCHANB2	0x24DB	Transmit CH2 Subframe B	0x0
DITCHANB3	0x24DC	Transmit CH3 Subframe B	0x0
DITCHANB4	0x24DD	Transmit CH4 Subframe B	0x0
DITCHANB5	0x24DE	Transmit CH5 Subframe B	0x0
S/PDIF User Bit Status Registers			
DITUSRBITA0	0x24E0	Transmit User Bit CH0 Subframe A	0x0
DITUSRBITA1	0x24E1	Transmit User Bit CH1 Subframe A	0x0

Register Listing

Register Mnemonic	Address	Description	Reset (Valid Bits)
DITUSRBITA2	0x24E2	Transmit User Bit CH2 Subframe A	0x0
DITUSRBITA3	0x24E3	Transmit User Bit CH3 Subframe A	0x0
DITUSRBITA4	0x24E4	Transmit User Bit CH4 Subframe A	0x0
DITUSRBITA5	0x24E5	Transmit User Bit CH5 Subframe A	0x0
DITUSRBITB0	0x24E8	Transmit User Bit CH0 Subframe B	0x0
DITUSRBITB1	0x24E9	Transmit User Bit CH1 Subframe B	0x0
DITUSRBITB2	0x24EA	Transmit User Bit CH2 Subframe B	0x0
DITUSRBITB3	0x24EB	Transmit User Bit CH3 Subframe B	0x0
DITUSRBITB4	0x24EC	Transmit User Bit CH4 Subframe B	0x0
DITUSRBITB5	0x24ED	Transmit User Bit CH5 Subframe B	0x0
DITUSRUPD	0x24EF	Transmit User Bit Update	0x0
S/PDIF Receiver Registers			
DIRCTL	0x24A8	Receiver Control	0x0
DIRSTAT	0x24A9	Receiver Status	0x20
DIRCHANL	0x24AA	Receiver Left Channel Status	0x0
DIRCHANR	0x24AB	Receiver Right Channel Status	0x0
Sample Rate Converter Registers			
SRCCTL0	0x2490	SRC0 Control	0x0
SRCCTL1	0x2491	SRC1 Control	0x0
SRCMUTE	0x2492	SRC Mute	0x0
SRCRAT0	0x2498	SRC0 Output to Input Ratio	0x8000 8000
SRCRAT1	0x2499	SRC1 Output to Input Ratio	0x8000 8000
UART0 Registers			
UART0THR	0x3C00	UART0 Transmit Hold	0x0
UART0RBR	0x3C00	UART0 Receive Buffer	0x0
UART0DLL	0x3C00	UART0 Divisor Latch Low	0x0

Registers Reference

Register Mnemonic	Address	Description	Reset (Valid Bits)
UART0IER	0x3C01	UART0 Interrupt Enable	0x0
UART0DLH	0x3C01	UART0 Divisor Latch High	0x0
UART0IIR	0x3C02	UART0 Interrupt ID	0x1
UART0LCR	0x3C03	UART0 Line Control	0x0
UART0MODE	0x3C04	UART0 Mode	0x20
UART0LSR	0x3C05	UART0 Line Status	0x60
UART0SCR	0x3C07	UART0 Scratch	Undefined
UART0RBRSH	0x3C08	UART0 Read Buffer Shadow	
UART0IIRSH	0x3C09	UART0 Interrupt Identification Shadow	
UART0LSRSH	0x3C0A	UART0 Line Status Shadow	
IUART0RX	0x3E00	Internal Memory Address for DMA Access with UART0 Receiver	
IMUART0RX	0x3E01	Internal Memory Modifier for DMA Access with UART0 Receiver	
CUART0RX	0x3E02	Word Count for DMA Access with UART0 Receiver	
CPUART0RX	0x3E03	Chain Point for DMA Access with UART0 Receiver	
UART0RXCTL	0x3E04	UART0 DMA Receiver Control	0x0
UART0RXSTAT	0x3E05	UART0 DMA RX Status	0x0
IUART0TX	0x3F00	Internal Memory Address for DMA Access with UART0 Transmitter	
IMUART0TX	0x3F01	Internal Memory Modifier for DMA Access with UART0 Transmitter	
CUART0TX	0x3F02	Word Count for DMA Access with UART0 Transmitter	
CPUART0TX	0x3F03	Chain Point for DMA access with UART0 Transmitter	
UART0TXCTL	0x3F04	UART0 DMA Transmit Control	0x0

Register Listing

Register Mnemonic	Address	Description	Reset (Valid Bits)
UART0TXSTAT	0x3F05	UART0 DMA Transmit Status	0x0
UART1 Registers			
UART1THR	0x4000	UART1 Transmit Hold	0x0
UART1RBR	0x4000	UART1 Receive Buffer	0x0
UART1DLL	0x4000	UART1 Divisor Latch Low	0x0
UART1IER	0x4001	UART1 Interrupt Enable	0x0
UART1DLH	0x4001	UART1 Divisor Latch High	0x0
UART1IIR	0x4002	UART1 Interrupt ID	0x1
UART1LCR	0x4003	UART1 Line Control	0x0
UART1MODE	0x4004	UART1 Mode	0x20
UART1LSR	0x4005	UART1 Line Status	0x60
UART1SCR	0x4007	UART1 Scratch	Undefined
UART1RBRSH	0x4008	UART1 Read Buffer Shadow	
UART1IIRSH	0x4009	UART1 Interrupt Identification Shadow	
UART1LSRSH	0x400A	UART1 Line Status Shadow	
IUART1RX	0x4200	Internal Memory Address for DMA Access with UART1 Receiver	
IMUART1RX	0x4201	Internal Memory Modifier for DMA Access with UART1 Receiver	
CUART1RX	0x4202	Word Count for DMA Access with UART1 Receiver	
CPUART1RX	0x4203	Chain Point for DMA Access with UART1 Receiver	
UART1RXCTL	0x4204	UART1 DMA Receiver Control	0x0
UART1RXSTAT	0x4205	UART1 DMA RX Status	0x0
IUART1TX	0x4300	Internal Memory Address for DMA Access with UART1 Transmitter	
IMUART1TX	0x4301	Internal Memory Modifier for DMA Access with UART1 Transmitter	

Registers Reference

Register Mnemonic	Address	Description	Reset (Valid Bits)
CUART1TX	0x4302	Word Count for DMA Access with UART1 Transmitter	
CUART1TX	0x4303	Chain Point for DMA access with UART1 Transmitter	
UART1TXCTL	0x4304	UART1 DMA Transmit Control	0x0
UART1TXSTAT	0x4305	UART1 DMA Transmit Status	0x0
TWI Registers			
TWIDIV	0x4400	SCL Clock Divider	0x0
TWIMITR	0x4404	Master Internal Time Reference	0x0
TWISCTL	0x4408	Slave Mode Control	0x0
TWISSTAT	0x440C	Slave Mode Status	0x0
TWISADDR	0x4410	Slave Mode Address	0x0
TWIMCTL	0x4414	Master Mode Control	0x0
TWIMSTAT	0x4418	Master Mode Status	0x0
TWIMADDR	0x441C	Master Mode Address	0x0
TWIIRPTL	0x4420	Interrupt Latch	0x0
TWIIMASK	0x4424	Interrupt Mask	0x0
TWIFIFOCTL	0x4428	FIFO Control	0x0
TWIFIFOSTAT	0x442C	FIFO Status	0x0
TXTWI8	0x4480	8-bit FIFO Transmit	0x0
TXTWI16	0x4484	16-bit FIFO Transmit	0x0
RXTWI8	0x4488	8-Bit FIFO Receive	Undefined
RXTWI16	0x448C	16-Bit FIFO Receive	Undefined

Register Listing

B PERIPHERAL INTERRUPT CONTROL

This appendix provides information about controlling interrupts as well as a complete listing of the registers that are used to configure and control programmable interrupts. For information on the `IRPTL`, `LIRPTL`, and `IMASK` registers, see *SHARC Processor Programming Reference*.

Interrupt Latency

The following

- For peripherals such as the timer or PWM which generate interrupts, a write into the peripheral's status register to clear the interrupt causes a certain amount of latency (due to the existence of register write effect latency).
- Interrupt-driven data transfers (core or DMA) from any peripheral that generates interrupts and which uses an ISR routine, a write into a peripheral data buffer (to clear the interrupt) or a control register causes a certain amount of latency (due to the existence of register write effect latency and buffer clock domains).

In both cases, if for example the program comes out of the interrupt service routine (RTI instruction) during that period of latency (maximum of 10 `CCLK` cycles), the interrupt is generated again. To avoid interrupt regeneration, use one of the following solutions.

Interrupt Acknowledge



The interrupt regeneration restriction does not apply to any SPORT in DMA operation mode.

1. Read an IOP register from the same peripheral block before the return from interrupt (RTI). The read forces the write to occur as shown in the example codes below.

```
ISR_SPI_Routine:
R0 = dm(i0,m0);
dm(TXSPI) = R0; /* write to SPI data buffer */
R0 = dm(SPICTL); /* force dummy read to terminate write */
rti;
```

```
ISR_PWM_Routine:
r1=PWM_STAT3;
dm(PWMGSTAT)=r1; /* W1C to PWM status reg */
r0=dm(PWMGSTAT); /* force dummy read to terminate write */
rti;
```

2. Add sufficient NOP instructions after a write. In the worst case, programs need to add ten NOP instructions after a write, as shown in the example code below.

```
ISR_Routine:
R0 = 0x0;
dm(SPICTL) = R0; /* or disable SPI control */
nop; nop; nop; nop; nop;
nop; nop; nop; nop; nop;
rti;
```

Interrupt Acknowledge

As previously discussed in this manual, interrupt driven I/O is advantageous in that programs do not need to poll the core. When an interrupt is triggered, the sequencer typically finishes the current instruction and jump to the IVT (interrupt vector table). From IVT the address then typically vectors to the ISR routine. The sequencer jumps into this routine,

performs program execution and then exits the routine by executing the RTI (return from interrupt) instruction. However this rule does not apply for all cases as is discussed below.

There are three interrupt acknowledge mechanisms used in an ISR routine:

- RTI instruction
- Read-only-to-Clear (ROC) status bit + RTI instruction
- Write-1-to clear (W1C) status bit + RTI instruction

The DAI/DPI interrupt controller is designed such that in order to terminate correctly, the latch register must be read to identify the source. Note this read does automatically acknowledge the request before exiting an interrupt routine. For the W1C mechanism, programs must write into the specific bit of the latch register in order to terminate the interrupt properly.

 If the acknowledge mechanism rules are not followed correctly, unwanted and sporadic interrupts will occur.

Interrupt Completion

On SHARC processors, interrupts are generated after *internal transfer completion* (when the DMA count register has expired). However, in some cases the transfer may not have terminated (due to different channel priorities) and valid data still resides in the peripheral's buffer, waiting to be transmitted. To overcome this problem, the interrupt *access completion* mode is introduced. In this mode the interrupt is generated when the last

Interrupt Priority

data has left the buffer. [Table B-1](#) provides an overview, for details refer to the specific peripheral's chapter.

Table B-1. Interrupt Acknowledge Mechanisms

Peripheral	Interrupt Source	Interrupt Access Completion	Interrupt Acknowledge
EPDMA1-0	DMA	Yes (ADSP-2137x only)	ISR requires RTI only
MTM	DMA	No	
SPORTs	Core/DMA	No	
SPI/SPIB	Core/DMA	No	
DAI	IDP, SPDIE, ASRC, MISCA	No	ISR requires read-only-to-clear (ROC-bits) and RTI
DPI	MISCB	No	
UART1-0	Core/DMA	No	
PWM TWI Timer2-0	Core	No	ISR requires write to clear (W1C) and RTI

Interrupt Priority

The following sections provide descriptions of the programmable interrupts that are used in the ADSP-21367/8/9 and ADSP-2137x processors. These registers allow programs to substitute the default interrupts for some other interrupt source.

[Table B-2](#) lists the locations to be programmed in the IOP programmable interrupt control registers (PICR) to route an IOP interrupt source to a corresponding processor interrupt location. Note that the shaded area denotes default routing.

[Table B-2](#) also defines the PICR bits which should be programmed to select the source for each priority interrupt. Priority programming can be

Peripheral Interrupt Control

accomplished by changing the sources for each priority interrupt. For example, if peripheral x should be given high priority, the high priority interrupt source should be set as that peripheral (x).

Table B-2. Peripheral Interrupt Controller Routing Table

Interrupt Name	Vector Address	Control Register (PICR)	Default Select Value	Default Function	Priority
P0I	0x2C	PICR0[4–0]	0x00	DAIHI interrupt	HIGHEST
P1I ¹	0x30	PICR0[9–5]	0x01	SPI interrupt	
P2I	0x34	PICR0[14–10]	0x02	GP timer-0 interrupt	
P3I	0x38	PICR0[19–15]	0x03	SPORT1 interrupt	
P4I	0x3C	PICR0[24–20]	0x04	SPORT3 interrupt	
P5I	0x40	PICR0[29–25]	0x05	SPORT5 interrupt	
P6I	0x44	PICR1[4–0]	0x06	SPORT0 interrupt	
P7I	0x48	PICR1[9–5]	0x07	SPORT2 interrupt	
P8I	0x4C	PICR1[14–10]	0x08	SPORT4 interrupt	
P9I ¹	0x50	PICR1[19–15]	0x09	EPDMA0 interrupt	
P10I	0x54	PICR1[24–20]	0x0A	GP Timer-1 interrupt	
P11I	0x58	PICR1[29–25]	0x0B	SPORT7 interrupt	
P12I	0x5C	PICR2[4–0]	0x0C	DAILI interrupt	
P13I	0x60	PICR2[9–5]	0x0D	EPDMA1 interrupt	
P14I	0x64	PICR2[14–10]	0x0E	DPI interrupt	
P15I	0x68	PICR2[19–15]	0x0F	MTM, DTCP interrupt	
P16I	0x6C	PICR2[24–20]	0x10	SPORT6 interrupt	
P17I	0x70	PICR2[29–25]	0x11	GP timer-2 interrupt	
P18I	0x74	PICR3[4–0]	0x12	SPIB interrupt	

Interrupt Priority

Table B-2. Peripheral Interrupt Controller Routing Table (Cont'd)

Interrupt Name	Vector Address	Control Register (PICR)	Default Select Value	Default Function	Priority
UART0RxI	All of these interrupts are not connected by default.		0x13	UART0 receive interrupt	
UART1RxI			0x14	UART1 receive interrupt	
UART0TxI			0x15	UART0 transmit interrupt	
UART1TxI			0x16	UART1 transmit interrupt	
TWII			0x17	Two-wire interface interrupt	
PWMI			0x18	PWM interrupt	
Reserved			0x1E	Reserved	
Logic High ²			0x1F	Software option to set IOP interrupts	

- 1 These interrupts have an option to be unmasked at reset. Therefore, the peripherals that boot the processor should be allocated these interrupts: (P1I, P9I).
- 2 Logic high can trigger a software based interrupt on any specific DMA channel (similar to core SFTxI interrupts).

Peripherals with Multiple Interrupt Vector Addresses

The TWI and the UART peripherals have multiple interrupt vector addresses. Both peripherals are already connected to the P14I (DPI) at default. However both have another sets of interrupt latches which are not routed by default. This gives more flexibility to change priority across the programmable interrupts since the DPI does not support high or low priority (unlike DAI).

Priority Interrupt Control Registers (PICRx)

This 32-bit read/write registers, shown in [Figure B-1](#) through [Figure B-4](#), control programmable priority interrupts and default interrupt sources. An example is shown below.

Route PWMI to P17I

```
#include <def21369.h>
ustat1=dm(PICR2);
bit set ustat1 P17I4|P17I3;          /*PWMI 0x18, I4-0= 11000*/
bit clr ustat1 P17I2|P17I1|P17I0;
dm(PICR2)=ustat1;
```

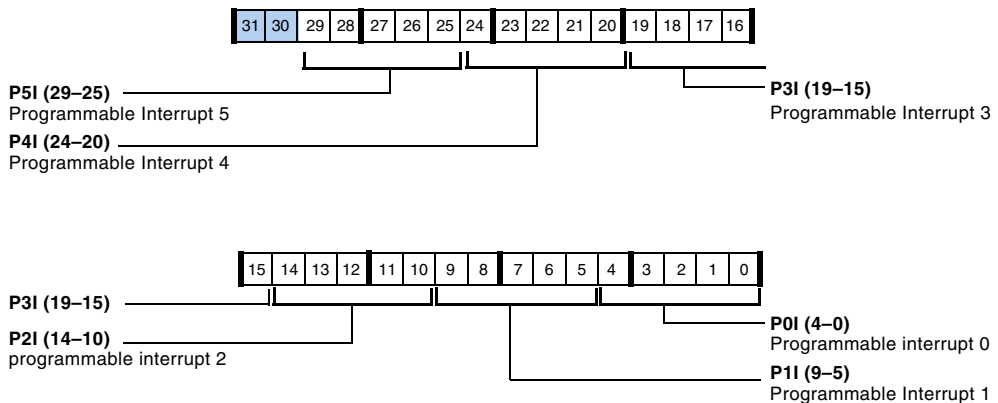

Figure B-1. PICR0 Register

Interrupt Priority

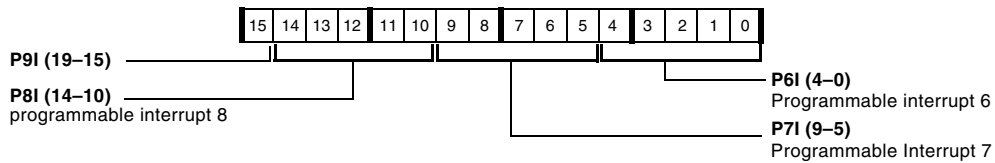
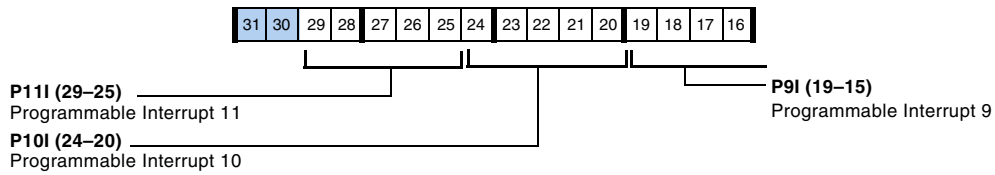

Figure B-2. PICR1 Register

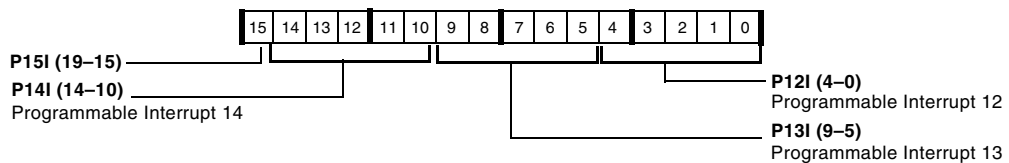
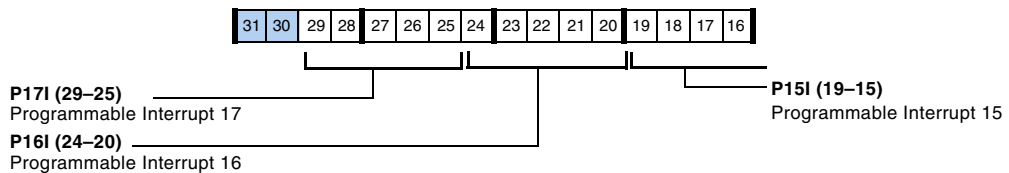

Figure B-3. PICR2 Register

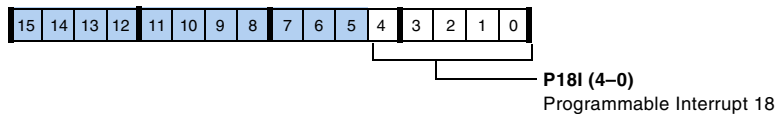

Figure B-4. PICR3 Register

C AUDIO FRAME FORMATS

This appendix introduces all the serial timing protocols used for audio inter-chip communications. These formats are listed and their availability in the various peripherals noted in [Table C-1](#).

Table C-1. Audio Format Availability

Frame Format	SPORTs	IDP/SIP	ASRC Input	ASRC Output	S/PDIF Tx	S/PDIF Rx	PCG
Serial	Yes						Yes
I ² S	Yes	Yes	Yes	Yes	Yes	Yes	Yes
Left-justified	Yes	Yes	Yes	Yes	Yes		Yes
Right-justified, 24-bit		Yes	Yes	Yes	Yes		Yes
Right-justified, 20-bit		Yes	Yes	Yes	Yes		Yes
Right-justified, 18-bit		Yes	Yes	Yes	Yes		Yes
Right-justified, 16-bit		Yes	Yes	Yes	Yes		Yes
TDM, 128 channel	Yes		Yes	Yes			Yes

Overview

The following protocols are available in the SHARC processor and are briefly described in this appendix. For complete information on the industry standard protocols, see the specification listings in each section.

- Standard Serial Mode
- Left-justified Mode (Sony format)
- I²S Mode (Sony/Philips format)
- Time Division Multiplex (TDM) Mode
- MOST Mode
- Right-justified Mode
- S/PDIF (consumer mode)
- EBU/AES3 (professional mode)

Standard Serial Mode

Most processors allow word lengths of 4 to 32 bits to be transmitted or received through their serial ports. For convenience, most AFE (analog front-end) devices operate with 16-bit word lengths for both data and status transfer between the AFE and processor. The serial ports (SPORTs) of most DSPs are designed for full-duplex operation. They differ from the typical serial interface of micro controllers in that they use a frame sync pulse to indicate the start of the data frame. In the case of full duplex asynchronous transfers, two separate FS pulses are used for transmit and receive. The typical micro controller serial interfaces use the serial clock (SCLK) as an indicator of serial data, meaning that the SCLK is only active when data is valid. The DSP serial interface can operate with a continuous

SCLK, in which the frame synchronization (FS) pulse indicates the start of valid data.

Serial mode allows a flexible timing which can be used in unframed mode or framed mode. In framed mode the user can select between timing for early and late frame sync. Moreover the word order can be selected as LSB or MSB first.

I²S Mode

The Inter-IC-Sound (I²S) bus protocol is a popular 3 wire serial bus standard that was developed to standardize communication across a wide range of peripheral devices. Today the I²S protocol has become the standard method of communicating with consumer and professional audio products.

The I²S protocol provides transmission of 2 channel (stereo) Pulse Code Modulation digital data, where each audio sample is sent MSB first. The following list shows applications that use this format.

- Audio D/A and A/D converters
- PC multimedia audio controllers
- Digital audio transmitters and receivers that support serial digital audio transmission standards, such as AES/EBU, S/PDIF, IEC958, CP-340, and CP-1201
- Digital audio signal processors
- Dedicated digital filter chips
- Sample rate converters



Timing diagrams for I²S, right-justified and left-justified formats can be found in the product-specific data sheet.

I²S Mode

The I²S bus transmits audio data from 8–32 bits and control signals over separate lines. The data line carries two multiplexed data channels—the left channel and the right channel. In I²S mode, if both channels on a SPORT are set up to transmit, then the SPORT transmits left and right I²S channels simultaneously. If both channels on a SPORT are set up to receive, the SPORT receives left and right I²S channels simultaneously. Data is transmitted in MSB-first format.

I²S consists, as stated above, of a bit clock, a word select and the data line. The bit clock pulses once for each discrete bit of data on the data lines. The bit clock operates at a frequency which is a multiple of the sample rate. The bit clock frequency multiplier depends on number of bits per channel, times the number of channels. For example, CD Audio with a sample frequency of 44.1 kHz and 32 bits of precision per (2) stereo channels has a bit clock frequency of 2.8224 MHz. The word select clock lets the device know whether channel 1 or channel 2 is currently being sent, since I²S allows two channels to be sent on the same data line.

Transitions on the word select clock also serve as a start-of-word indicator. The word clock line pulses once per sample, so while the bit clock runs at some multiple of the sample frequency, the word clock always matches the sample frequency. For a two channel (stereo) system, the word clock is a square wave, with an equal number of bit clock pulses clocking the data to each channel. In a mono system, the word clock pulses one bit clock length to signal the start of the next word, but is no longer be square. Instead, bit clocking transitions occur with the word clock either high or low.

Note the major difference between I²S and left/right justified modes is a left MSB data shift by one SCLK cycle in relation to the frame.

Standard I²S data is sent from MSB to LSB, starting at the left edge of the word select clock, with one bit clock delay. This allows both the transmitting and receiving devices to ignore the audio precision of the remote

device. If the transmitter is sending 32 bits per channel to a device with only 24 bits of internal precision, the receiver ignores the extra bits of precision by not storing the bits past the 24th bit. Likewise, if the transmitter is sending 16 bits per channel to a receiving device with 24 bits of precision, the receiver zero-fills the missing bits. This feature makes it possible to mix and match components of varying precision without re configuration.

Left-Justified Mode

Left-justified mode (also known as SONY Format) is a mode where in each frame sync cycle two samples of data are transmitted/received—one sample on the high segment of the frame sync, the other on the low segment of the frame sync. Prior to development of the I²S standard, many manufacturers used a variety of non-standard stereo modes. Some companies continue to use this mode, which is supported by many of today's audio front-end devices.

Programs have control over various attributes of this mode. One attribute is the number of bits (8- to 32-bit word lengths). However, each sample of the pair that occurs on each frame sync must be the same length.

Right-Justified Mode

Right-justified mode is a mode where in each frame sync cycle two samples of data are transmitted/received—one sample on the high segment of the frame sync, the other on the low segment of the frame sync. Prior to development of the I²S standard, many manufacturers used a variety of non-standard stereo modes. Some companies continue to use this mode, which is supported by many of today's audio front-end devices.

TDM Mode

Programs have control over various attributes of this mode. One attribute is the number of bits (8- to 32-bit word lengths). However, each sample of the pair that occurs on each frame sync must be the same length.

TDM Mode

Many applications require multiple I/O channels to implement the desired system functions (such as telephone line and acoustic interfaces). Because most DSPs provide one, or at most two SPORTs, and one of these may be required for interfacing to the host or supervisory processor, it may be impractical, if not impossible, to dedicate a separate SPORT interface to each AFE connection.

The solution is to devise a way to connect a series of serial devices to one SPORT. Different converter manufacturers have approached this task in different ways. In essence, though, there are only two choices; either a time division multiplexing (TDM) approach, where each device is active on the SPORT in a particular time slot, or a cascading approach, where all devices are daisy chained together and data is transferred by shifting it through the chain and then following with a latching signal or a serial protocol. [Figure C-1](#) illustrates a pulsed frame clock for the TDM operation.

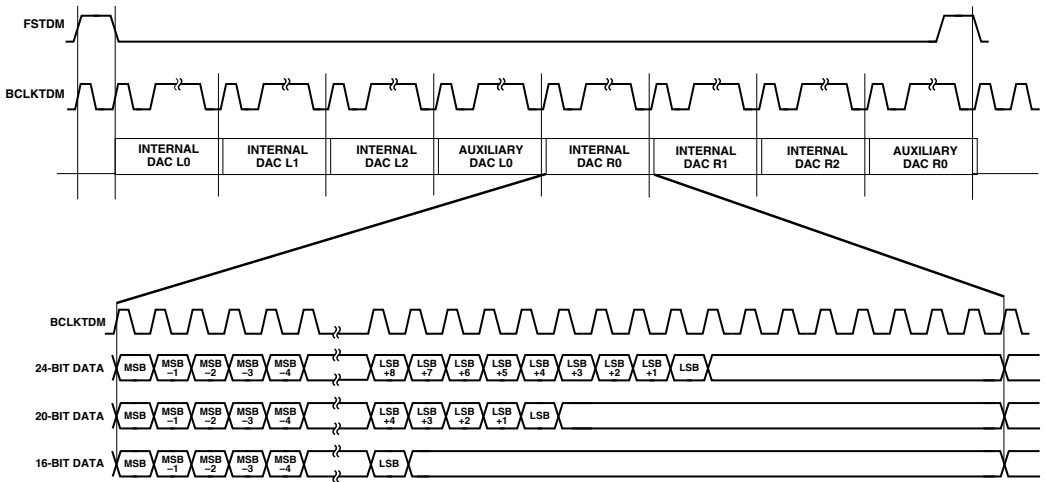

Figure C-1. TDM Mode Timing

Packed TDM Mode

This mode allows applications to send more than the standard 32 bits per channel available through standard I²S mode. Packed mode is implemented using standard TDM mode. Packed mode supports up to 128 channels as does TDM mode as well as the maximum of (128 x 32) bits per left or right channel. As shown in [Figure C-2](#) packed I²S waveforms are the same as the wave forms used in TDM mode, except that the frame sync is toggled for every frame, and therefore emulates I²S mode. So it is a hybrid between TDM and I²S mode.

TDM Mode

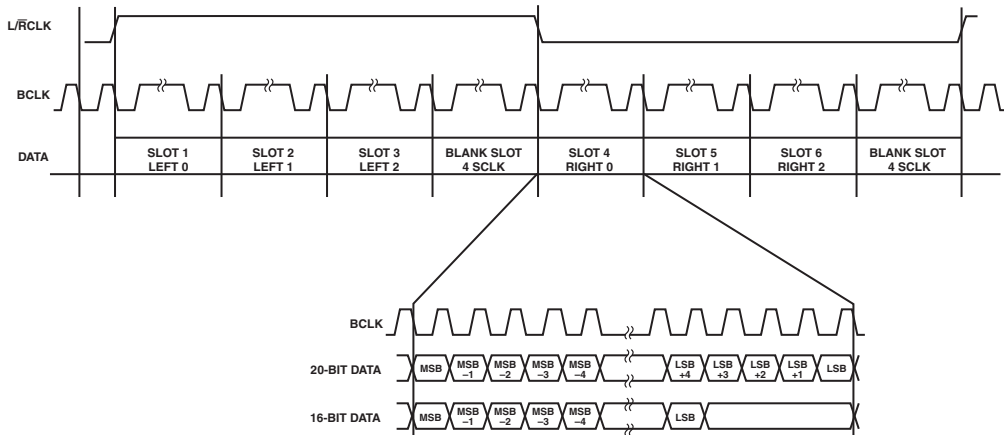

Figure C-2. Packed TDM Mode

MOST Mode

A special packed TDM mode is available that allows four channels to be fit into a space of 64-bit clock cycles. This mode is called packed TDM4 mode, or MOST™ mode. MOST (Media Oriented Systems Transport) is a networking standard intended for interconnecting multimedia components in automobiles and other vehicles. Many integrated circuits intended to interface with a MOST bus use a packed TDM4 data format.

Figure C-3 illustrates a word length of 16 bits for a timing diagram of the packed TDM4 mode. This figure is shown with a negative BCLK polarity, a negative LRCLK polarity, and an MSB delay of 1. The MSB position of the serial data must be delayed by one bit clock from the start of the frame (I²S position).

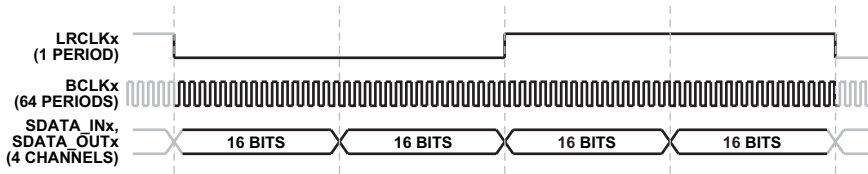

Figure C-3. Packed TDM4 Mode

AES/EBU/SPDIF Formats

For this section, it is important to be familiar with serial digital application interface standards IEC-60958, EIAJ CP-340, AES3 and AES11.

S/PDIF data is transmitted as a stream of 32-bit data words. A data frame consists of 384 words in total, with 192 data words transmitted for the A stereo channel, and 192 data words transmitted for the B stereo channel.

The difference between the AES/EBU and S/PDIF protocol is the channel status bit. If the channel status bit is not set, then:

- 0 = Consumer/professional
- 1 = Normal/compressed data
- 2 = Copy prohibit/copy permit
- 3 = 2 channels/4 channels
- 4 = n/a
- 5 = No pre-emphasis/pre-emphasis

AES/EBU/SPDIF Formats

There is one channel status bit in each sub-frame, (comprising of 192 bits per audio block). This translates to $192/8 = 24$ bytes available (per audio block). The meaning of the channel status bits are as follows

- The biphase encoded AES3 stream is composed of subframes (Figure C-5 on page C-13). Subframes consist of a preamble, four auxiliary bits, a 20-bit audio word, a validity bit, a user bit, a channel status bit, and a parity bit.
 - The preamble indicates the start of the subframe. The four auxiliary bits normally are the least significant bits of the 24-bit audio word when pasted to the 20-bit audio word. In some cases, the auxiliary bits are used to convey some kind of other data indicated by the channel status bits.
 - The validity bit (if cleared, =0) indicates the audio sample word is suitable for direct analog conversion. User data bits may be used in any way desired by the program. The channel status bit conveys information about the status of the channel. Examples of status are length of audio sample words, number of audio channels, sampling frequency, sample address code, alphanumeric source, and destination codes and emphasis. The parity bit is set or cleared to provide an even number of ones and of zeros for time slots 4-31.
 - Each frame in the AES3 stream is made up of two subframes. The first subframe is channel A, and the second subframe is channel B. A block is comprised of 192 frames. The channel status is organized into two 192 bit blocks, one for channel A and one for channel B. Normally, the channel status of channel A is equal to channel B. It is extremely rare that they are ever different. Three different preambles are used to indicate the start of a block and the start of channel A or B.
1. Preamble Z indicates the start of a block and the start of subframe channel A

2. Preamble X indicates the start of a channel A subframe when not at the start of a block.
3. Preamble Y indicates the start of a channel B subframe.

The user bits from the channel A and B subframes are simply strung together. For more information, please refer to the AES3 standard.

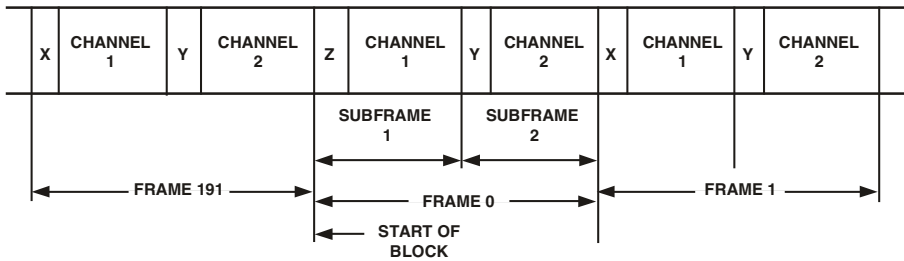

Figure C-4. S/PDIF Block Structure

The data carried by the SPDIF interface is transmitted serially. In order to identify the assorted bits of information the data stream is divided into frames, each of which are 64 time slots (or 128 unit intervals¹) in length (Figure C-4). Since the time slots correspond with the data bits, the frame is often described as being 64 bits in length.

A frame is uniquely composed of two subframes. The first subframe normally starts with preamble X. However, the preamble changes to preamble Z once every 192 frames. This defines the block of frames structure used to organize the channel status information. The second subframe always starts with preamble Y.

¹ The unit interval is the minimum time interval between condition changes of a data transmission signal.

Subframe Format

Each frame consists of two subframes. [Figure C-5](#) shows an illustration of a subframe, which consists of 32 time slots numbered 0 to 31. A subframe is 64 unit intervals in length. The first four time slots of each subframe carry the preamble information. The preamble marks the subframe start and identifies the subframe type. The next 24 time slots carry the audio sample data, which is transmitted in a 24-bit word with the least significant bit (LSB) first. When a 20-bit coding range is sufficient, time slots 8 to 27 carry the audio sample word with the LSB in time slot 8. Time slots 4 to 7 may be used for other applications. Under these circumstances, the bits in time slots 4 to 7 are designated auxiliary sample bits. If the source provides fewer bits than the interface allows (either 20 or 24), the unused LSBs are set to logic 0.

This functionality is important when using the SPDIF receiver in common applications where there are multiple types of data to handle. If there are PCM audio data streams as well as encoded data streams, for example a CD audio stream and a DVD audio stream with encoded data, there is a danger of incorrectly passing the encoded data directly to the DAC. This results in the ‘playing’ of encoded data as audio, causing loud odd noises to be played. The non-audio flag provides an easy method to mark the this type of data.

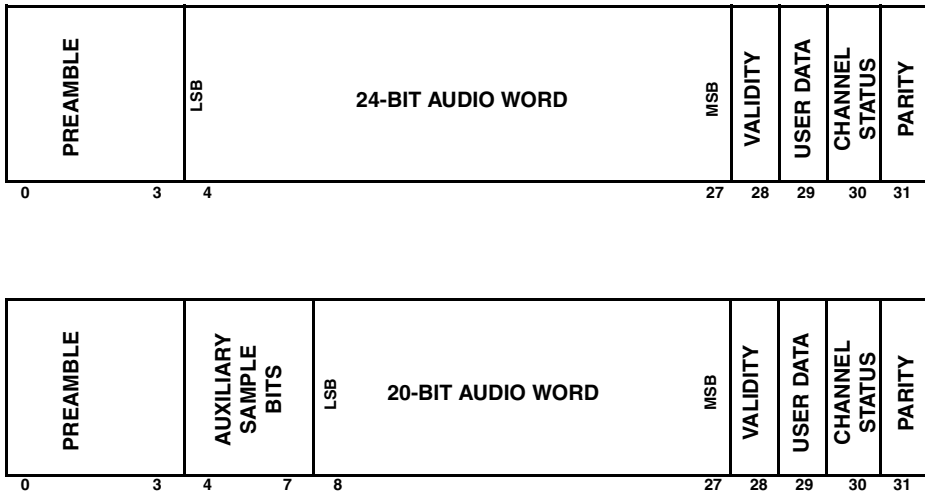

Figure C-5. Subframe Format

After the audio sample word, there are four final time slots which carry:

1. **Validity bit (time slot 28).** The validity bit is logic 0 if the audio sample word is suitable for conversion to an analog audio signal, and logic 1 if it is not. This bit is set if the `CHST_BUF_ENABLE` bit and the `VALIDITY_A` (`VALIDITY_B` for channel 2) bit is set in the `SPDIF_TX_CTL` register. This bit is also set if the corresponding bit given with the sample is set.
2. **User data bit (time slot 29).** This bit carries user-specified information that may be used in any way. This bit is set if the corresponding bit given with the left/right sample is set.
3. **Channel status bit (time slot 30).** The channel status for each audio signal carries information associated with that audio signal, making it possible for different channel status data to be carried in the two subframes of the digital audio signal. Examples of information to be carried in the channel status are: length of audio sample

words, number of audio channels, sampling frequency, sample address code, alphanumeric source and destination codes, and emphasis.

Channel status information is organized in 192-bit blocks, subdivided into 24 bytes. The first bit of each block is carried in the frame with preamble Z.

4. **Parity bit (time slot 31).** The parity bit indicates that time slots 4 to 31 inclusive will carry an even number of ones and an even number of zeros (even parity). The parity bit is automatically generated for each subframe and inserted into the encoded data.

The two subframes in a frame can be used to transmit two channels of data (channel 1 in subframe 1, channel 2 in subframe 2) with a sample rate equal to the frame rate. Alternatively, the two subframes can carry successive samples of the same channel of data, but at a sample rate that is twice the frame rate. This is called single-channel, double-frequency (SCDF). [For more information, see “Data Output Mode” on page 10-13.](#)

Channel Coding

To minimize the direct-current (dc) component on the transmission line, to facilitate clock recovery from the data stream, and to make the interface insensitive to the polarity of connections, time slots 4 to 31 are encoded in bi-phase mark.

Each bit to be transmitted is represented by a symbol comprising two consecutive binary states. The first state of a symbol is always different from the second state of the previous symbol. The second state of the symbol is identical to the first if the bit to be transmitted is logic 0. However, it is different if the bit is logic 1.

[Figure C-6](#) shows that the ones in the original data end up with mid cell transitions in the bi-phase mark encoded data, while zeros in the original

data do not. Note that the bi-phase mark encoded data always has a transition between bit boundaries.

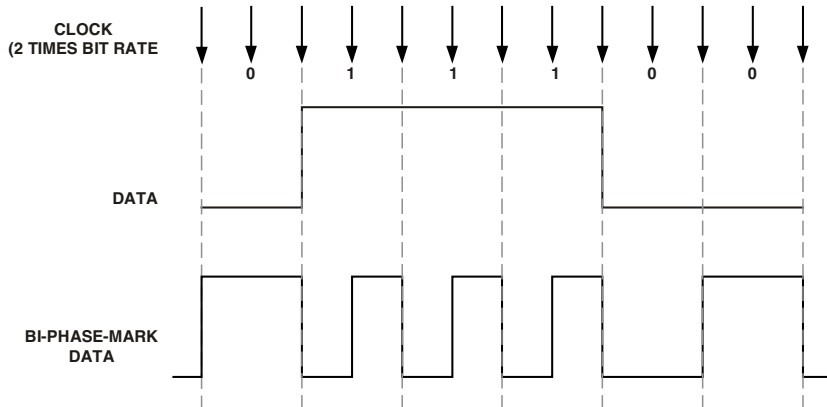

Figure C-6. Bi-phase Mark Encoding

Preambles

Preambles are specific patterns that provide synchronization and identify the subframes and blocks. To achieve synchronization within one sampling period and to make this process completely reliable, these patterns violate the bi-phase mark code rules, thereby avoiding the possibility of data imitating the preambles.

A set of three preambles, shown in [Table C-2](#), are used. These preambles are transmitted in the time allocated to four time slots at the start of each subframe (time slots 0 to 3) and are represented by eight successive states. The first state of the preamble is always different from the second state of the previous symbol (representing the parity bit).

AES/EBU/SPDIF Formats

Table C-2. Preambles

Preamble	Preceding state 0	Preceding state 1	Description
X	11100010	00011101	Subframe 1
Y	11100100	00011011	Subframe 2
Z	11101000	00010111	Subframe 1 and block start

Like bi-phase code, the preambles are dc free and provide clock recovery. They differ in at least two states from any valid bi-phase sequence.

INDEX

Numerics

- 128-channel TDM, 7-3
- 16-bit SDRAM address map, 3-30
- 16-bit word, 7-46, 17-20
- 32-bit SDRAM address map, 3-27
- 32-bit word, 3-61, 3-63, 3-87, 4-4, 7-41, 7-43, 8-6, 8-10, 8-12, 8-19, 17-18, 17-19
- 32-bit word, SPORT buffer, 7-42
- 48-bit word, 3-62, 17-16
- 8-bit boot (SPI), 17-17
- 8-bit word, 17-21, A-22, A-158

A

- AAC compressed format, 10-18
- AC-3 format, 10-18
- accuracy (PWM), 5-23
- active low frame sync select for frame sync (INVFSx) bit, 11-12
- active state multichannel receive frame sync select (LMFS) bit, 7-19
- AD1855 stereo DAC, use with SPI, 12-11
- address
 - AMI, 3-59
 - chain pointer register, 2-28
 - circular buffer, 2-7
 - column, row and bank address mapping (32-bit), 3-28
 - conflicts, 2-26
 - core to external memory, 3-27
 - destination, 2-17

address *(continued)*

- DMA transfer direction, 2-19
 - external chain pointer register, 2-10
 - external memory, 2-23
 - external port scatter/gather DMA, 2-16
 - external port TCB, 2-12
 - external port TCB, circular DMA, 2-13
 - external port TCB, delay line DMA, 2-13
 - generator, DMA, 2-20
 - index register, 2-22
 - instruction execution from external memory, 3-61
 - internal/external index, 2-31
 - logical vs. physical, 3-62
 - map, 16-bit SDRAM, 3-30
 - map, 32-bit SDRAM, 3-27
 - mapping, SDRAM, 3-26
 - modifier, DMA, 2-19
 - predictive, 3-9
 - SDRAM, 3-21, 3-24, 3-25
 - SDRAM, logical map, 3-35
 - SDRAM read, 3-41
 - SPI TCB, 2-11
 - SPORT TCB, 2-11
 - TCB allocation and, 2-28
 - TCB start, 2-7
 - UART TCB, 2-12
- address bus (ADDR) pin, 3-50
- addressing
- 7-bit in TWI, 15-2
 - AMI, external, 3-14

Index

addressing *(continued)*

- byte in SDRAM, [3-37](#)
- chain pointer, example, [2-29](#)
- chain pointer registers, [2-10](#)
- DMA controller, [2-20](#)
- general call in TWI, [15-14](#)
- internal index register, [2-22](#)
- IOP, [2-22](#)
- mixing instructions and data, [3-67](#)

AMI

- See also* external port, SDRAM, shared memory
- control (AMICTLx) register, [A-21](#) to [A-24](#)
- DMA, [3-8](#)
- external memory addressing, [3-14](#)
- reading external memory, [3-59](#)
- read/write throughput, [3-87](#)
- status (AMISTAT) register, [A-24](#)

AMI bits

- ACK pin enable (ACKEN), [A-22](#)
- buffer flush (FLSH), [A-23](#)
- bus hold cycle (HC), [A-23](#)
- bus idle cycle (HC), [A-23](#)
- most significant word first (MSWF), [A-22](#)
- packing disable (PKDIS), [A-22](#)
- predictive read disable (NO_OPT), [A-24](#)
- read hold cycle (RHC), [A-24](#)
- wait state enable (WS), [A-23](#)

AMIEN, [A-22](#)

arbitration, fixed/floating, [2-37](#)

architecture

- TWI controller, [15-7](#)

asynchronous memory interface. *See* AMI

asynchronous serial communications (UART), [14-7](#)

audio

- biphase encoded in S/PDIF, [10-3](#)
- data formats, IDP, [8-16](#)

audio *(continued)*

- formats, IDP, [8-6](#)
 - formats, S/PDIF, [10-7](#), [10-16](#)
 - non-linear data, S/PDIF, [10-17](#)
 - restriction with SPORTs, [7-10](#)
 - transmission standards, SPORTs, [C-3](#)
- audio formats, [C-1](#) to [C-9](#)
- autobaud detection, [14-6](#)
- automotive products, [1-2](#)

B

bank

- SDRAM address mapping, [3-26](#) to [3-31](#)

base registers, [2-7](#)

baud rate, [17-14](#)

- setting, [12-31](#), [12-37](#)

UART, [14-5](#), [14-11](#), [14-12](#)

BHD (buffer hang disable) bit, [7-54](#)

bidirectional connections through the signal routing unit, [6-14](#)

bidirectional functions (transmit, receive), [7-3](#)

biphase

- encoded audio stream, [10-4](#), [10-15](#)
- routing data, [10-5](#)

bit types, [A-3](#)

block diagram

IDP, [8-7](#)

IDP channel 0, [8-9](#)

I/O processor, [2-25](#)

PWM, [5-2](#)

S/PDIF transmitter, [10-8](#)

SPI, [12-10](#)

SPORTs, [7-13](#)

SRC, [9-6](#)

TWI controller, [15-7](#)

boolean operator

OR, [8-32](#)

- booting
 - bootstrap loading, [17-7](#)
 - DMA use in, [2-18](#)
 - SPI master mode, [17-13](#)
 - SPI packing, [17-17](#)
 - SPI slave mode, [17-16](#)
 - buffer
 - addressing, [2-22](#)
 - data, [2-8](#)
 - DMA use in, [2-19](#)
 - SPORT data, [7-1](#)
 - TCB allocation, [2-28](#)
 - buffer, pin, [6-7](#)
 - buffer hang disable (BHD) bit, [7-54](#), [A-76](#), [A-81](#), [A-86](#)
 - buses
 - arbitration, [3-48](#)
 - bus master timeout, [3-57](#)
 - contention, [12-35](#)
 - errors in, [3-44](#)
 - external bus data width (BW) bit, [A-22](#)
 - external port, [2-37](#)
 - granting, [12-22](#)
 - hold cycle bit, [A-23](#)
 - I²S and, [C-3](#)
 - idle cycle bit, [A-23](#)
 - I/O address (IOA), [2-22](#)
 - I/O data (IOD), [12-35](#)
 - IO data (IOD), [2-25](#)
 - I/O processor (IOP), [7-48](#)
 - master, [3-52](#)
 - master timeout, [3-57](#)
 - peripheral, [2-37](#)
 - shared memory bus arbitration, [3-48](#)
 - slave, [3-52](#)
 - synchronization, [3-53](#)
 - bus lock (BUSLK) bit, [3-58](#)
 - bus master, current (CRBMx) bit, [A-32](#)
 - bus master count (BCNT) register, [3-58](#)
 - bus master max time-out (BMAX) register, [3-57](#)
 - bus request $\overline{\text{BRx}}$ signal, [3-53](#)
 - bus synchronized (BSYN) bit, [3-54](#), [A-31](#)
 - bus transition cycle (BTC), [3-49](#)
 - bypass as a one-shot (strobe pulse), [11-13](#)
- ## C
- capacitors
 - bypass, [17-37](#)
 - decoupling, [17-37](#)
 - CAS latency
 - bit (SDCL), [A-26](#)
 - center-aligned paired PWM
 - double-update mode, [5-10](#)
 - single-update mode, [5-9](#)
 - chain assignment, I/O processor, [2-28](#)
 - chained DMA, [2-18](#), [2-24](#), [2-27](#), [2-30](#)
 - chained DMA enable (SCHEN_A and SCHEN_B) bit, [A-76](#), [A-80](#)
 - chained DMA sequences, [2-10](#)
 - chain pointer (CPSPI) registers, SPI, [12-34](#), [12-36](#)
 - chain pointer (CPSPx) registers, SPORTs, [7-47](#)
 - chain pointer (CPx) registers, [2-28](#)
 - chain pointer registers (general), [2-10](#)
 - enable (SCHEN_A and SCHEN_B) bit, [7-47](#), [A-85](#)
 - SPI, [2-11](#)
 - SPI chained DMA enable (SPICHEN) bit, [12-36](#)
 - SPORTs, [2-11](#), [7-47](#), [A-76](#), [A-80](#), [A-85](#)
 - UART, [2-12](#), [14-15](#)
 - chaining enable bit (CHEN), [2-30](#)
 - chain insertion mode, SPORT, [7-48](#)
 - chain pointer registers, [2-7](#), [2-10](#)
 - changing SPI configuration, [12-23](#)

Index

- channel
 - allocation for DMA, [2-3](#)
 - arbitration, fixed/floating, [2-37](#)
 - defined, [2-2](#)
 - DMA, [2-18](#)
 - granting access, [2-27](#)
 - interrupt, [2-38](#) to [2-41](#)
 - priority, [2-27](#)
 - priority for DMA, [2-25](#)
 - registers, listed, [2-32](#)
- channel B transmit status register
 - (SPDIF_TX_CHSTB), [A-122](#), [A-123](#)
- channel selection registers, [7-38](#)
- circular buffer start address, [2-7](#)
- circular DMA, [2-13](#)
- clearing interrupts, latches, [B-3](#)
- clock A source (CLKASOURCE) bit,
 - [A-113](#)
- clocks and system clocking
 - clock and frame sync frequencies (DIVx)
 - registers, [7-8](#)
 - clock distribution, [17-33](#)
 - clock polarity (CLKPL) bit, [A-148](#)
 - clock rising edge select (CKRE) bit,
 - [A-75](#), [A-85](#)
 - core clock, [16-6](#), [16-7](#)
 - disabling the clock, [16-6](#), [16-7](#)
 - hardware control, [16-4](#)
 - internal clock select (ICLK) bit, [A-74](#),
 - [A-80](#), [A-84](#)
 - managing for power savings, [16-11](#)
 - output divider, [16-4](#)
 - peripheral clock, [16-6](#), [16-7](#)
 - precision clock generator registers, [11-20](#)
 - SDRAM controller, [3-6](#)
 - selecting clock ratios, [16-4](#)
 - software control, [16-4](#)
 - source select (MSTR) bit, [A-74](#), [A-80](#),
 - [A-84](#)
- clocks and system clocking *(continued)*
 - SPI clock phase select (CPHASE) bit,
 - [A-148](#)
 - SPORTs, [7-8](#)
 - VCO encodings, [16-5](#)
- column, row and bank address mapping
 - (32-bit), [3-28](#)
- commands
 - auto-refresh, [3-25](#)
 - bank activate, [3-20](#)
 - load mode register, [3-19](#)
 - NOP, [3-25](#)
 - precharge, [3-21](#)
 - read/write, [3-21](#)
 - self-refresh, [3-44](#)
- compand data in place, [7-3](#)
- companding (compressing/expanding), [7-3](#)
- conditioning input signals, [17-33](#)
- configuring frame sync signals, [7-12](#)
- connecting peripherals through DAI, [6-16](#)
- connections
 - group A, clock signals, [6-24](#)
 - group A, DPI, input routing signals,
 - [A-130](#)
 - group B, DPI, pin assignment signals,
 - [A-134](#)
 - group C, DPI, pin enable signals, [A-138](#)
- controller, SDRAM, [3-16](#)
- core access read optimization, [3-42](#)
- core address mapping, [3-27](#)
- core transmit/receive operations, [12-19](#)
- count (CSPx) DMA registers, [2-6](#)
- count (CSPx) registers, [2-23](#)
- count (IDP_DMA_Cx) registers, [8-20](#),
 - [8-21](#)
- CROSSCORE software, [1-6](#)
- crossstalk, reducing, [17-37](#)
- CSPx (peripheral DMA counter) registers,
 - [2-6](#), [2-23](#)

D

DAI

- clock routing control registers (group A), [6-24](#)
- configuration macro, [6-43](#)
- connecting peripherals with, [6-16](#)
- control registers, clock routing control registers (Group A), [A-41](#)
- DAI interrupt falling edge (DAI_IRPTL_FE) register, [8-28](#)
- DAI interrupt rising edge (DAI_IRPTL_RE) register, [8-28](#)
- DAI_IRPTL_FE register
 - as replacement to IMASK, [6-39](#)
- DAI_IRPTL_H register, [8-23](#)
- DAI_IRPTL_H register as replacement to IRPTL, [6-39](#)
- DAI_IRPTL_L register as replacement to IRPTL, [6-39](#)
- DAI_IRPTL_PRI register, [6-39](#), [8-28](#)
- DAI_PIN_PULLUP register, [A-68](#)
- DAI_PIN_STAT register, [A-68](#)
- DAI_STAT register, [8-22](#), [A-101](#), [A-103](#)
- edge-related interrupts, [6-37](#)
- interrupt controller, [6-32](#) to [6-38](#)
- interrupt controller registers, [A-69](#)
- interrupts, [6-33](#)
- ping-pong DMA status (SRU_PINGx_STAT) register, [A-102](#), [A-103](#)
- pin status (DAI_PIN_STAT) register, [A-68](#)
- resistor pullup enable (DAI_PIN_PULLUP) register, [A-68](#)
- routing, [6-20](#)
- rules for routing, [6-20](#)
- selection group E (miscellaneous signals), [A-63](#)
- SPORT SRU signal connections, [7-5](#)

DAI *(continued)*

- status (DAI_STAT) register, [A-101](#), [A-103](#)
- system configuration, sample, [6-42](#)
- system design, [6-4](#)
- DAI_IRPTL_RE register
 - as replacement to IMASK, [6-39](#)
- DAI registers
 - pin status (DAI_PIN_STAT), [A-142](#)
 - resistor pull up enable (DAI_PIN_PULLUP), [A-68](#), [A-142](#)
 - resistor pullup enable (DAI_PIN_PULLUP), [A-68](#), [A-142](#)
- data
 - direction control (SPTRAN) bit, [A-77](#), [A-81](#), [A-86](#)
- data direction control (SPTRAN) bit, [A-77](#), [A-81](#), [A-86](#)
- data-independent frame sync, [7-20](#)
 - (DIFS) mode, [7-20](#)
- data ready (DR) status flag (UART), [14-12](#)
- data type
 - and companding, [7-14](#)
 - and formatting (non-multichannel), [7-21](#)
- data type select (DTYPE) bit, [A-73](#), [A-84](#)
- data words
 - single word transfers, [7-43](#)
 - transferring, [7-26](#), [7-38](#)
 - UART, [14-11](#)
- dead time example (PWM), [5-16](#)
- debug, [7-60](#), [17-33](#)
 - DAI use in, [6-10](#), [6-40](#)
 - SPI, [12-28](#), [12-29](#)
 - SPORT, [7-54](#)
- delay line DMA, [2-13](#)
- destination address, [2-17](#)
- development tools, [1-6](#)
- DIFS (data independent frame sync select) bit, [A-75](#), [A-80](#)

Index

digital applications interface. *See* DAI
digital peripheral interface, *See* DPI
DIVEN (PLL divider enable) bit, 16-13,
 A-8
divisor, UART, 14-4, A-163
divisor (DIVx) registers, 7-8, 7-11
DIVx (divisor) registers, A-70
DLAB (divisor latch access) bit, A-157
DMA
 access, granting, 2-27
 arbitration, 2-37
 base registers, 2-7
 booting, 2-18
 bus priority, 2-37
 chained, SPI, 2-11
 chained, SPORT, 2-11
 chained, UART, 2-12, 14-15
 chaining, 2-18, 2-25, 2-27 to 2-31
 chaining enable bit (CHEN), 2-30
 chain loading priority, 2-31
 chain pointer registers, 2-7, 2-10
 channel, buffer registers, listed, 2-32
 channel, parameter registers, 2-32
 channel allocation, 2-3, 2-31
 channel paths, 2-20
 channel priority, 2-25
 channel priority, external port, 2-37,
 A-13
 channels, 2-2
 circular buffered, 2-7, 2-19
 configuring in the I/O processor, 2-44
 control/status registers, 2-32
 data buffer, 2-28, 2-32
 direction change (external port), 2-18
 extended parameter registers, 2-8
 external port bus, 2-37
 external port bus priority, A-13
 handshake, 2-26
 index addresses, 2-22
 interrupts, 2-38 to 2-41

DMA *(continued)*
 loading chain, 2-30
 miscellaneous external port parameter
 registers, 2-8
 offset value, 2-22
 operation, master mode, 12-34
 operation, slave mode, 12-36
 parameter registers, 2-32
 ping-pong, 2-18, 2-19
 ping-pong, IDP, 8-21
 ping-pong enable (IDP_PING) bits,
 A-98
 program controlled interrupt (PCI) bit,
 2-10, 2-11, 2-12, 7-48, 12-14, 14-24
 read optimization example, 3-43
 rotating peripheral priority, 2-38
 SPI slave mode, 12-32, 12-33
 SPORT chain status bits (DMACHSxy),
 A-91
 SPORT status bit (DMASxy), A-90,
 A-91
 standard (non chained), 2-18
 starting/stopping, 2-24
 switching from receive to transmit mode,
 12-40
 switching from transmit to receive mode,
 12-39
 TCB, 2-11 to 2-16, 2-27
 TCB allocation, 2-28
 TCB size, 2-28
 transfer control block *See* DMA
 TCB
 transfer direction, external port, 2-19
 transfers, 8-20
 transmit or receive operations (SPI),
 12-34
DMACx (external port DMA registers),
 A-15, A-17
Dolby, DTS audio standards (S/PDIF),
 10-14

- DPI
 - connections, group A, [A-130](#) to [A-134](#)
 - connections, group B, [A-134](#) to [A-137](#)
 - connections, group C, [A-138](#) to [A-141](#)
 - pin assignment (group B) signals, [A-134](#)
 - pin enable (group C) signals, [A-138](#)
- DSP
 - architectural overview, [1-3](#)
- DSxEN (SPI device select) bits, [12-34](#), [A-156](#)
- DTS format, [10-18](#)
- DTYPE, [7-21](#)
- DTYPE (data type) bits, [A-73](#), [A-84](#)
- DXS_B, DXS_A (data buffer channel A/B status) bit, [A-78](#), [A-82](#), [A-87](#)

- E**
- early vs. late frame syncs, [7-27](#)
- edge-related interrupts, [6-37](#)
- ELSI (enable RX status interrupt) bit, [A-161](#)
- emergency dead time example, [5-16](#)
- enable
 - DMA interrupt (INTEN) bit, [12-26](#)
 - EXT_CLK mode, [13-15](#)
 - external clock synchronization, PCG, [11-20](#)
 - external port (asynchronous memory interface), [A-22](#)
 - multichannel mode in SPORTs, [A-89](#)
 - PCGs, [11-18](#)
 - peripheral timer, [13-4](#), [13-20](#)
 - pin buffer, timer, [13-3](#)
 - pulse width modulation groups, [5-19](#)
 - PWM_OUT mode, [13-8](#)
 - SPI DMA, [12-34](#)
 - SPID \bar{S} (ISSEN) bit, [12-28](#)
 - SPI slave, [12-21](#)
 - synchronize (counter) bits, PWM, [5-24](#)
 - WIDTH_CAP mode, [13-13](#)
 - enable receive buffer full interrupt (ERBFI) bit, [A-160](#)
 - enable transmit buffer empty interrupt (ETBEI) bit, [A-160](#)
 - endian format, [12-2](#), [A-73](#)
 - equation
 - duty cycles in PWM, [5-9](#)
 - frame sync frequency, [7-10](#)
 - frame sync pulse (SPORT), [7-9](#)
 - peripheral timer period, [13-11](#)
 - pulse width modulation switching frequency, [5-6](#)
 - SDRAM clock, [3-33](#)
 - SDRAM refresh rate, [3-32](#)
 - serial clock frequency, [7-9](#)
 - serial port clock divisor, [7-9](#)
 - SPI clock baud rate, [A-153](#)
- errors
 - internal bus (SDRAM), [3-44](#)
 - SPORT error control register, [A-93](#)
 - TWI master mode, [15-22](#), [15-23](#)
 - TWI repeat start, [15-24](#)
 - TWI slave transfer, [15-11](#), [15-20](#)
 - UART baud rate, [14-6](#)
 - UART sampling, [14-13](#)
- examples
 - bus synchronization, [3-103](#)
 - capacitor placement, [17-37](#)
 - chain pointer addressing, [2-29](#)
 - DAI multiplexing, [6-19](#)
 - edge-aligned PWM, [5-17](#)
 - external port DMA read, [3-43](#)
 - FIR filter loop, [3-69](#)
 - multibank SDRAM, [3-35](#)
 - multibank SDRAM with data packing, [3-36](#)
 - multiple processor system, [3-39](#)
 - pin buffer, [6-7](#)
 - power management, [16-11](#)
 - PWM deadtime, [5-12](#)

Index

- examples *(continued)*
 - PWM emergency dead time, [5-16](#)
 - PWM switching frequencies, [5-7](#)
 - read optimization, [3-42](#)
 - reset generator, [17-42](#)
 - reset the digital PLL, [10-26](#)
 - rotating priority arbitration, [3-57](#)
 - SDRAM clock, [3-33](#)
 - single processor system, [3-38](#)
 - SPI interface with AD1855 DAC, [12-11](#)
 - SRU connections, [6-20](#), [6-20](#) to [6-24](#)
 - SRU mnemonic, [6-7](#)
 - timing for a SPORT multichannel transfer, [7-33](#)
- examples, timing
 - SPI clock, [12-17](#)
 - SPI transfer protocol, [12-16](#)
 - SPORT framed vs. unframed data, [7-28](#)
 - SPORT normal vs. alternate framing, [7-28](#)
- execution stalls, bus transition, [3-51](#)
- EXT_CLK (external event watchdog)
 - mode, [13-5](#)
- extended parameter registers, DMA, [2-8](#)
- external event watchdog (EXT_CLK)
 - mode, [13-2](#), [13-15](#)
- external memory
 - 28-bit addressing, [2-23](#)
 - access restrictions, [3-105](#), [3-106](#)
 - access timing, [3-5](#)
 - addressing, AMI, [3-14](#)
 - arbitration, [3-8](#)
 - banks, [3-16](#), [3-35](#)
 - boot-up code for interrupt vector tables, [3-62](#)
 - chained DMA and, [2-18](#)
 - DMA bus, [2-23](#), [2-37](#)
 - DMA transfers, [2-19](#)
 - executing instructions from, [3-61](#)
 - interface, [3-8](#)
- external memory *(continued)*
 - most significant word first (MSWF) bit, [A-22](#)
 - packing and unpacking data (PKDIS) bits, [A-22](#)
 - reads, [3-59](#)
 - restrictions, access, [3-105](#), [3-106](#)
 - SDRAM, [3-35](#)
 - SDRAM operation, [3-17](#)
 - select signals (MSx), [3-35](#)
 - SPORT data transfers, [7-40](#)
 - writes, [3-59](#)
- external port
 - address, DMA, [2-19](#)
 - bus, [2-37](#)
 - bus hold cycle bit, [A-23](#)
 - bus idle cycle bit, [A-23](#)
 - bus priority, [A-13](#)
 - channel priority, [2-37](#), [A-13](#)
 - core address mapping, [3-27](#)
 - data pin mode select (EPDATA) bits, [A-5](#)
 - DMA bus, [2-37](#)
 - DMA read optimization, [3-43](#)
 - DMA registers, [2-23](#), [A-15](#), [A-17](#), [A-20](#)
 - external code throughput, [3-88](#)
 - external index addressing, [2-23](#)
 - feature summary, [3-2](#)
 - instruction packing, [3-62](#)
 - read hold cycle (RHC) bits, [A-24](#)
 - TCB, [2-12](#)
 - transfer direction, DMA, [2-19](#)
- external port bits
 - bank select (BxSD), [A-13](#)
 - bus priority (EPBR), [A-13](#)
 - data enable (DATA), [A-14](#)
 - delay line write pointer write back status (WBS), [A-17](#), [A-20](#)
 - DMA chaining enable (CHEN), [A-16](#), [A-18](#)

external port bits *(continued)*
 DMA chain status (CHS), [A-17](#), [A-20](#)
 DMA circular buffer enable (CBEN),
[A-16](#), [A-19](#)
 DMA delay-line enable (DLEN), [A-16](#),
[A-19](#)
 DMA direction (TRAN), [A-16](#), [A-18](#)
 DMA enable (DMAEN), [A-16](#), [A-18](#)
 DMA external interface status (EXTS),
[A-17](#), [A-20](#)
 DMA FIFO status (DFS), [A-16](#), [A-20](#)
 DMA flush FIFO (DFLSH), [A-16](#), [A-19](#)
 DMA transfer direction status (DIRS),
[A-17](#), [A-20](#)
 DMA transfer status (DMAS), [A-17](#),
[A-20](#)
 flush tap list FIFO (TFLSH), [A-16](#)
 freeze length core (FRZCR), [A-14](#)
 freeze length (FRZDMA), [A-13](#)
 internal DMA complete interrupt
 (INIRT), [A-19](#)
 on the fly control loading enable
 (OFCEN), [A-19](#)
 tap list DMA enable (TLEN), [A-19](#)
 tap list FIFO status (TFS), [A-16](#)
 tap list loading status (TLS), [A-17](#)
 write back of EPEI after reads/writes
 (WRBEN), [A-19](#)
 external port DMA direction change, [2-18](#)
 external port registers, [A-11](#) to [A-20](#)
 AMI control (AMICTLx), [A-21](#)

F

FIFO

see also buffer
 data packing in IDP, [8-18](#)
 IDP, [8-6](#)
 IDP modes use, [8-11](#)
 receive, SPORT, [7-16](#)

FIFO *(continued)*

SPI, [12-9](#)
 SPI DMA, [12-21](#), [12-34](#), [12-42](#)
 to memory data transfer, [8-14](#)
 transmit, SPORT, [7-41](#)
 FIR filter inner loop, [3-69](#)
 flags
 flag interrupt mode (IRQxEN) bits, [A-5](#)
 input/output (FLAGx) pins, [7-12](#), [12-9](#)
 restriction with SPI bits, [5-4](#)
 SPORT pins, [7-12](#)
 FLAGx pins, [7-12](#), [12-9](#)
 framed versus unframed data, [7-25](#)
 frame sync
 A source (FSASOURCE) bit, [A-113](#)
 early vs. late, [7-27](#)
 frequencies, [7-8](#)
 in multichannel mode, [7-32](#)
 internal vs. external, [7-18](#)
 output, synchronizing, [11-20](#)
 PCG B source (FSBSOURCE) bit,
[11-13](#)
 rates, setting, [7-28](#)
 routing control (SRU_FS0) registers
 (group C), [A-51](#)
 signals, configuring, [7-12](#)
 frame sync delay (MFD), [7-32](#)
 frame sync required (FSR) bit, [A-75](#)
 framing bits, [7-29](#), [7-30](#)
 FRFS (frame on rising frame sync) bit,
[7-29](#), [7-30](#)
 FS_BOTH (frame sync both) bit, [A-76](#)
 FSR (frame sync required) bit, [A-75](#)
 full-duplex operation, specifications, [7-11](#)

G

generators, optional reset, [17-42](#)
 GM (get more data) bit, [12-21](#), [12-31](#),
[A-146](#)
 ground plane, in PCB design, [17-37](#)

Index

group descriptions, signal routing unit,
6-17

H

handshake, DMA, 2-26

handshaking, external port, 3-47

hardware interrupt

signals $\overline{\text{IRQ2-0}}$, 17-32

hold cycle (external bus) bit, A-23

hold off, processor bus transition, 3-51

hold time

inputs, 17-36

recognition of asynchronous input,
17-36

hysteresis on $\overline{\text{RESET}}$ pin, 17-34

I

I²C port. *See* TWI controller

I²S

(Tx/Rx on left channel first), 7-23

ICLK (internal clock select) bit, A-74,
A-80, A-84

identification code (IDC) bit, A-32

idle cycle (external bus) bit, A-23

IDP

address, DMA, 8-20

address, ping-pong DMA, 8-21

buffer, 2-8

channel 0 diagram, 8-9

control (IDP_CTL0) register, 8-29,
A-95

control (IDP_CTL1) register, 8-28,
A-98, A-99

(DAI) interrupt service routine
steps, 8-23

DMA count (IDP_DMA_Cx) register,
8-20, 8-21

IDP *(continued)*

DMA index (IDP_DMA_Ix) register,
8-20, 8-21

DMA modify (IDP_DMA_Mx) register,
8-20, 8-21

FIFO (IDP_FIFO) register, 8-14, 8-15,
8-23

FIFO memory data transfer, 8-14

FIFO register (IDP_FIFO register), 8-14
illustrated, 8-2

interrupt driven transfers, 8-15

interrupts, 8-15, 8-28

memory data transfer, 8-14

packing modes, 8-10, 8-13

PDAP control (IDP_PDAP_CTL)
register, A-99

PDAP control (IDP_PP_CTL) register,
A-99

ping-pong DMA, 8-21

polarity of left-right encoding, 8-18

serial inputs, 8-6

IDP bits

bus hang disable (IDP_BHD), 8-25,
A-96

clear buffer overflow (IDP_CLROVR),
A-97

DMA enable (IDP_DMA_EN), 8-29,
A-97

DMA status (IDP_DMAx_STAT),
8-22, A-103

enable (IDP_ENABLE), 8-29, 8-30,
A-97

FIFO number of samples
(IDP_FIFOSZ), A-103

FIFO samples exceed interrupt
(IDP_FIFO_GTN_INT), 8-28

frame sync format (IDP_SMODEx),
8-15, 8-17, 8-27, A-97

IDP_DMA_EN bit
do not set, 8-16

- IDP bits *(continued)*
- monitor number of samples
(IDP_NSET), [A-96](#)
 - PDAP clock edge
(IDP_PDAP_CLKEDGE), [8-27](#),
[A-101](#)
 - PDAP enable (IDP_PDAP_EN), [8-30](#),
[A-101](#)
 - PDAP input mask bits, [8-27](#)
 - PDAP packing mode
(IDP_PDAP_PACKING), [A-101](#)
 - PDAP reset (IDP_PDAP_RESET),
[A-101](#)
 - ping-pong DMA enable (IDP_PING)
bits, [A-98](#)
 - port select (IDP_PORT_SELECT),
[A-100](#)
 - port select (IDP_PP_SELECT), [8-27](#)
reset (IDP_PDAP_RESET) bit, [A-101](#)
 - IDP_CTL0 (input data port control)
register, [8-29](#), [A-95](#)
 - IDP_CTL1 (input data port control)
register, [8-28](#), [A-98](#), [A-99](#)
 - IFS (internal frame sync select) bit, [A-75](#),
[A-85](#)
 - IISPx (serial port DMA internal index)
registers, [2-4](#), [2-22](#)
 - IMSPI (serial peripheral interface address
modify) register, [12-34](#), [12-36](#)
 - IMSPx (SPORT DMA address modifier)
registers, [2-5](#), [2-22](#)
 - index registers, [2-22](#)
 - INDIV (input divisor) bit, [A-8](#)
 - input setup and hold time, [17-36](#)
 - input signal conditioning, [17-33](#)
 - input slave select enable (ISSEN) bit,
[12-28](#), [A-146](#)
 - input synchronization delay, [17-29](#)
 - INTEN (DMA interrupt enable) bit, [12-26](#)
 - interconnections, master-slave, [12-3](#)
 - internal index, [2-23](#)
 - internal memory
 - DMA index (IDP_DMA_Ix) registers,
[8-20](#), [8-21](#)
 - DMA index (IISPx) registers, [2-4](#), [2-22](#)
 - DMA modifier (IDP_DMA_Mx)
registers, [8-20](#), [8-21](#)
 - DMA modifier (IMSPx) registers, [2-5](#),
[2-22](#)
 - internal serial clock, setting, [7-28](#), [7-29](#)
 - internal vs. external frame syncs, [7-18](#)
 - INTERR (enable interrupt on error) bit,
[12-26](#)
 - interrupts, [2-38](#) to [2-41](#)
 - interrupt, SPORTs, [7-49](#)
 - interrupt and timer pins, [17-29](#)
 - interrupt controller, digital applications
interface, [6-32](#)
 - interrupt driven transfers
starting, [8-29](#), [8-30](#)
 - interrupt latch (IRPTL) register, [12-26](#)
 - interrupt latch/mask (LIRPTL) registers,
[12-26](#)
 - interrupts
 - conditions for generating interrupts,
[7-46](#)
 - digital applications interface, [6-33](#)
(enable RX status interrupt) bit, [A-161](#)
 - external memory booting, [3-62](#)
 - peripheral timers, [13-18](#)
 - priority interrupt control registers
(PICR), [B-4](#)
 - restrictions, [B-3](#)
 - SRC, [9-16](#)
 - vector, sharing, [7-50](#)
 - INVFSx (active low frame sync select for
frame sync) bits, [11-12](#)
 - I/O interface to peripheral devices, [7-1](#)

Index

- I/O processor, [2-19](#)
 - address bus (IOA), [2-22](#)
 - addressing, DMA controller, [2-20](#)
 - and addressing, [2-22](#)
 - baud rate, [12-37](#)
 - buffer, [2-32](#)
 - DMA data, [2-28](#)
 - bus priority, [2-37](#)
 - bus priority, external port, [2-37](#), [A-13](#)
 - bus structure, [2-25](#)
 - chain assignment, [2-28](#)
 - chained DMA, [2-10](#)
 - chain pointer (CPSPI) register, [2-10](#)
 - chain pointer registers, [2-7](#)
 - configuring DMA, [2-44](#)
 - count registers, [2-6](#), [2-23](#)
 - DMA channel registers, [2-32](#)
 - IDP buffer, [2-8](#)
 - miscellaneous external port parameter registers, [2-8](#)
 - standard (non chained) DMA, [2-18](#)
 - TCB memory allocation, [2-27](#)
 - transfer types, [2-1](#)
- ISSS (input service select) bit, [A-156](#)

- K**
- kernel boot timing, [17-22](#)

- L**
- LAFS (late transmit frame sync select) bit, [7-23](#), [7-27](#), [A-75](#), [A-80](#)
- latchup, [17-33](#)
- latency
 - input synchronization, [17-29](#)
 - in SPORT registers, [7-55](#)
- left-justified mode, [7-28](#), [C-5](#)
 - SRC timing, [9-9](#)
- left-justified sample pair mode
 - control bits, [7-29](#)
 - Tx/Rx on FS rising edge, [7-23](#)
- length registers, DMA, [2-8](#)
- LIRPTL (interrupt) registers, [12-26](#)
- logical vs. physical address, [3-62](#)
- loopback mode
 - timers, [13-19](#)
- loopback mode, SPI, [12-29](#)
- LRFS (SPORT logic level) bit, [7-19](#)
- LSBF (least significant bit first) bit, [A-73](#)

- M**
- making connections via the signal routing unit, [6-20](#)
- maskable interrupts, SPI, [12-27](#)
- master input slave output (MISOx) pins, [12-8](#), [12-14](#)
 - slave output, [12-14](#)
- master mode enable, [7-24](#), [7-30](#)
- master mode operation, SPI, [12-30](#)
- master out slave in (MOSIx) pin, [12-8](#), [12-14](#)
- master-slave interconnections, [12-3](#)
- memory
 - addressing, [2-23](#)
 - data transfer, FIFO, [8-14](#)
 - mapped IOP (RXSPI and TXSPI) buffer registers, [12-27](#)
 - memory-mapped registers, [A-2](#)
 - TCB allocation for DMA, [2-27](#)
- memory read \overline{RD} pin, [3-50](#)
- memory select (flags) programming (MSEN) bit, [A-5](#)
- memory select (\overline{MSx}) pins, [3-50](#), [3-54](#)
- memory transfer types, [2-1](#)
- MISCAx_I (signal routing unit external miscellaneous) register, [11-13](#)
- miscellaneous external port parameter registers, [2-8](#)

- miscellaneous signal routing
 - (SRU_EXT_MISCx) registers (Group E), [A-61](#)
 - MISOx pins, [12-8](#), [12-14](#)
 - mode
 - left-justified (IDP), [8-6](#)
 - left-justified (SPORT), [7-28](#), [C-5](#)
 - loopback (SPORT), [A-90](#)
 - right-justified (IDP), [8-6](#)
 - serial mode settings (IDP), [8-17](#)
 - single channel double frequency (SPDIF), [10-13](#)
 - standard serial, [7-24](#), [C-2](#)
 - TDM (SPORT), [7-3](#)
 - timer, [A-183](#)
 - two channel (SPDIF), [10-13](#)
 - mode fault error (MME) bit, [12-27](#), [12-28](#)
 - mode fault (multimaster error) SPI DMA status (MME) bit, [12-27](#), [12-28](#)
 - modes
 - audio, [C-2](#) to [C-9](#)
 - MOSIx pins, [12-8](#), [12-14](#)
 - most significant byte first (MSBF) bit, [A-147](#)
 - MPEG-2 format, [10-18](#)
 - MRxCCSx (SPORT receive compand) registers, [A-93](#)
 - MRxCSx (SPORT receive select) registers, [A-92](#)
 - MSBF (most significant byte first) bit, [A-147](#)
 - MTxCCSx (serial port transmit compand) registers, [A-92](#)
 - MTxCCSy and MRxCCSy (multichannel compand select) registers, [7-12](#)
 - MTxCSx (serial port transmit select) registers, [A-92](#)
 - multibank operation, [3-35](#)
 - multibank operation with data packing, [3-36](#)
 - multichannel compand select (MTxCCSy and MRxCCSy) registers, [7-12](#)
 - multichannel operation, [7-31](#)
 - multiple processor system example, [3-39](#)
 - multiplexing
 - pins, [17-27](#) to [17-33](#)
 - PWM pins, [A-6](#)
 - multiprocessing. *See* shared memory
- N**
- normal frame sync, [7-27](#)
- O**
- offset value, index registers, [2-22](#)
 - one shot frame sync A or B (STROBEx) bits, [11-12](#)
 - one shot option (STROBEB) bit, [11-13](#)
 - OPMODE (serial port operation mode) bit, [7-25](#), [7-29](#)
 - optimize
 - core read, [3-42](#)
 - OR, logical, [8-32](#)
- P**
- package availability, [1-2](#)
 - packing
 - 16 to 32-bit packing (PACK) bit, [7-21](#), [7-46](#), [7-50](#), [A-74](#), [A-80](#), [A-84](#)
 - modes in IDP_PP_CTL, illustrated, [8-10](#)
 - serial peripheral interface (PACKEN) bit, [A-149](#)
 - packing instructions, [3-62](#)
 - page size (SDRAM), [A-28](#)
 - parallel data acquisition port control (IDP_PP_CTL) register, [A-99](#)
 - parallel data acquisition port (PDAP), [8-32](#)
 - parameter registers, DMA, [2-32](#)

Index

PCG

- active low frame sync select for frame sync (INVSFSx) bits, [11-12](#)
 - bypass mode, [11-12](#)
 - clock A source (CLKASOURCE) bit, [A-113](#)
 - clock input source enable (CLKx_SOURCE_IOP) bit, [A-116](#)
 - clock with external frame sync enable (FSx_SYNC) bit, [A-116](#)
 - control (PCG_CTL_Ax) registers, [11-13](#), [A-110](#), [A-112](#)
 - division ratios, [11-18](#)
 - enable clock (ENCLKx) bit, [A-110](#), [A-112](#)
 - enable frame sync (ENFSx) bit, [A-110](#), [A-112](#)
 - frame sync A source (FSASOURCE) bit, [11-13](#), [A-113](#)
 - frame sync B source (FSBSOURCE) bit, [11-13](#), [A-113](#)
 - frame sync input source enable (CLKx_SOURCE_IOP) bit, [A-116](#)
 - frame sync with external frame sync enable (FSx_SYNC) bit, [A-116](#), [A-118](#)
 - one shot frame sync A or B (STROBEx) bits, [11-12](#)
 - one shot option, [11-13](#)
 - PCG_CTLA0 (control) register, [A-110](#), [A-112](#)
 - phase shift of frame sync, [11-15](#)
 - pulse width for frame sync (PWFSx) bit, [A-114](#)
 - pulse width (PCG_PW) register, [11-13](#)
 - synchronization with the external clock, [11-20](#)
- PCI (program control interrupt) bit, [2-10](#)

PDAP

- enable (IDP_PDAP_EN) bit, [A-101](#)
- port mask bits (IDP_Pxx_PDAPMASK), [A-100](#)
- (rising or falling) clock edge (IDP_PDAP_CLKEDGE) bit, [A-101](#)
- PDAP control (IDP_PDAP_CTL) register, [A-99](#)
- peripheral devices, I/O interface to, [7-1](#)
- peripherals
 - memory mapped, [3-8](#)
- peripheral timers
 - external event watchdog (EXT_CLK) mode, [13-5](#), [13-15](#)
 - input/output (TMRx) pin, [13-6](#)
 - interrupts, [13-18](#)
 - invalid conditions, [13-9](#)
 - modes, [13-6](#)
 - period, configuring, [13-4](#)
 - period equation, [13-11](#)
 - pulse width count and capture (WDTH_CAP) mode, [13-13](#)
 - pulse width modulation (PWMOUT) mode, [13-8](#)
 - rectangular signals, [13-10](#)
 - RTI instruction, [13-19](#)
 - single pulse generation, [13-12](#)
 - TIMERx pin, [13-6](#)
 - watchdog, [13-19](#)
 - word count (TMxCNT) registers, [13-6](#)
- peripheral timers registers, [13-4](#)
 - high word period (TMxPRD) registers, [13-7](#)
 - high word pulse width (TMxW) registers, [13-7](#)
 - period (TMxPRD) registers, [13-4](#)
 - pulse width (TMxW) registers, [13-5](#)
 - timer control (TMxCTL), [13-6](#)
 - timer count (TMxCNT), [13-4](#), [13-6](#)

- peripheral timers registers *(continued)*
 - timer global status and control (TMSTAT), 13-4
 - timer width (TMxW), 13-5
 - timer word period (TMxPRD), 13-4
 - word count (TMxCNT) registers, 13-4
- phase shift of frame sync, 11-15
- physical vs. logical address, 3-62
- PICR (programmable interrupt priority) registers, B-4
- PICR register, 2-42, B-5
- pin
 - buffer example, 6-7
- ping-pong DMA, 2-18, 2-19
- ping-pong DMA, IDP, 8-21
- pins
 - ACK, enabling, A-22
 - descriptions, 16-15, 17-2
 - FLAGx, 7-12
 - pin states during SDRAM commands, 3-26
 - RESET, 17-34
 - timer (through SRU), 13-6
- plane, ground, 17-37
- PLLBP (PLL bypass bit), 16-7
- PLLBP (PLL bypass mode) bit, 16-7, 16-13
- PLLDx (PLL divider) bits, A-8
- PLLM (PLL multiplier) bit, A-8
- PMCTL (power management control) register, 16-4, A-8
- polarity
 - IDP left-right encoding, 8-18
 - PWM double-update mode, 5-10
 - PWM single update mode, 5-9
 - SPDIF connections, C-14
 - SPI clock, 12-14, 12-23
- power management control (PMCTL) register, A-7
- power management control register (PMCTL), 16-4, A-8
- power management examples, 16-11
- power savings, 16-6, 16-7, 16-11
- power supply, monitor and reset generator, 17-42
- power-up, SDRAM (SDPM) bit, A-26
- power-up, *See system design*
- power-up reset circuit, 17-42
- preambles, S/PDIF, C-16
- precision clock generators. *See* PCG
- predictive address vs. real address, 3-9
- predictive reads, disable bit (NO_OPT), A-24
- printed circuit board design, 17-37
- priority, rotating priority arbitration example, 3-57
- processor core, overview, 1-3
- product details, 1-2
- program control interrupt (PCI) bit, 2-10
- program controlled interrupt bit (PCI), 2-10, 2-11, 2-12, 7-48, 12-14, 14-24
- programmable interrupt registers (PICRx), B-4
- programmable interrupts, listed, 2-42, B-5
- programming model
 - TWI controller, 15-19
- pulse, clock, in serial ports, 7-11
- pulse, frame sync delay in serial ports, 7-32
- pulse, frame sync formula, 7-9
- pulse width count and capture (WDTH_CAP) mode, 13-13
- pulse width modulation (PWMOOUT) mode, 13-8
- PWM
 - 16-bit read/write duty cycle registers, 5-7
 - accuracy in, 5-23
 - block diagram, 5-2
 - center-aligned paired PWM double-update mode, 5-10
 - channel duty control (PWMA, PWMB) registers, A-39

Index

PWM *(continued)*

- crossover mode, [5-14](#)
 - equations, [5-8](#) to [5-11](#)
 - global control (PWMGCTL) register, [A-33](#)
 - global status (PWMGSTAT) register, [A-35](#)
 - switching frequency equation, [5-6](#)
- PWM bits
- crossover (PWM_AXOV, PWM_BXOV), [5-14](#)
- PWMGCTL (pulse width modulation global control) register, [A-33](#)
- PWMGSTAT (pulse width modulation global status) register, [A-35](#)
- PWMOUT (pulse width modulation) mode, [13-8](#)

R

- read-only bit description (RO), [A-3](#)
- read-only-to-clear bit description (ROC), [A-3](#)
- read (\overline{RD}) pin, [3-50](#)
- read-write bit description (RW), [A-3](#)
- receive busy (overflow error) SPI DMA status (SPIOVF) bit, [A-152](#)
- receive data, serial port (RXSPx) registers, [2-8](#)
- receive data (RXSPI) buffer, [12-9](#)
- receive overflow error (SPIOVF) bit, [12-26](#), [12-42](#), [12-43](#)
- receive shift (RXSR) register, [12-8](#)
- refresh rate control (SDRRC) register, [A-30](#)
- refresh rate in SDRAM, [3-32](#)
- register drawings, reading, [A-2](#)
- registers, *See* peripheral specific registers
- register writes and effect latency, SPORTs, [7-41](#)
- reset
 - generators, [17-41](#)

\overline{RESET} pin, [17-34](#)

- input hysteresis, [17-34](#)
- resetting the digital PLL, [10-26](#)
- resolution (PWM), [5-23](#)
- restrictions
 - external memory access, [3-105](#), [3-106](#)
 - interrupts, [B-3](#)
 - SDRAM, [3-27](#)
 - SPORTs, [7-31](#)
- right justified mode, [C-5](#)
- right-justified mode
 - SRC, [9-9](#)
 - SRC, timing, [9-9](#)
- rotating DMA priority, [2-38](#)
- rotating priority arbitration example, [3-57](#)
- rotating priority bus arbitration (RPBA) pin, [3-56](#)
- ROVF_A or TUVF_A (channel A error status) bit, [A-78](#), [A-82](#)
- ROVF_A or TUVF_A (serial port error status) bits, [A-78](#), [A-82](#)
- ROVF_B or TUVF_B (channel B error status) bit, [A-82](#), [A-86](#), [A-87](#)
- RS-232 device, restrictions, [7-12](#)
- RXFLSH (flush receive buffer) bit, [12-39](#), [12-41](#), [12-42](#)
- RXS_A (data buffer channel B status) bit, [A-78](#), [A-82](#), [A-87](#)
- RXSPI, RXSPIB (SPI receive buffer) registers, [12-19](#), [12-27](#)
- RXSPx (serial port receive buffer) registers, [2-8](#)
- RXSR (SPI receive shift) register, [12-8](#)
- RXS (SPI data buffer status) bit, [A-155](#)
- RX_UACEN (DMA receive buffer enable) bit, [14-5](#)

S

- sampling clock period, UART, [14-13](#)
- sampling point, UART, [14-13](#)

- saving power, [16-6](#), [16-7](#), [16-11](#)
- scatter/gather DMA, [2-16](#)
- SCHEN_A and SCHEN_B (serial port chaining enable) bit, [A-76](#), [A-80](#), [A-85](#)
- SDEN (serial port DMA enable) bit, [A-76](#), [A-80](#), [A-85](#)
- SDRAM, [3-35](#), [3-36](#)
 - bus errors, [3-44](#)
 - clock equation, [3-33](#)
 - core address mapping, [3-27](#)
 - multibank operation, [3-34](#)
 - refresh rate, [3-32](#)
 - restrictions, [3-27](#)
- SDRAM bits
 - burst stop (NOBSTOP), [A-28](#)
 - CAS latency (SDCL), [A-26](#)
 - column address width (SDCAW), [A-27](#)
 - disable clock and control (DSDCTL), [A-26](#)
 - external data path width (X16DE), [A-27](#)
 - force auto refresh (Force AR), [A-27](#)
 - force load mode register write (Force LMR), [A-28](#)
 - force precharge (Force PC), [A-28](#)
 - optional refresh (SDORF), [A-27](#)
 - page size is 128 words (PGSZ 128), [A-28](#)
 - pipeline option with external register buffer (SDBUF), [A-28](#)
 - power-up mode (SDPM), [A-26](#)
 - power-up sequence start (SDPSS), [A-27](#)
 - RAS setting (SDTRAS), [A-26](#)
 - RDC setting (SDTRCD), [A-28](#)
 - refresh delay (RDIV), [A-30](#), [A-31](#)
 - row address width (SDRAW), [A-28](#)
 - RP setting (SDTRP), [A-26](#)
 - self-refresh enable (SDSRF), [A-27](#)
 - WR setting (SDTWR), [A-27](#)
- SDRAM controller, [3-16](#)
 - addressing (16-bit), [3-30](#) to [3-31](#)
 - addressing (32-bit), [3-28](#) to [3-29](#)
 - burst disable, [A-28](#)
 - calculating refresh rate, [3-32](#)
 - clock frequencies, [3-6](#)
 - external memory access timing, [3-5](#)
 - power-up sequence, [A-27](#), [A-28](#)
 - read/write command, [3-21](#)
 - refresh rate (SDRRC) register, [3-32](#)
 - setting bank column address width, [A-28](#)
 - write before precharge (SDTWR) bit, [3-6](#)
- SDRAM controller commands
 - auto-refresh, [3-25](#)
 - bank activate, [3-20](#)
 - command pin states, [3-26](#)
 - load mode register, [3-19](#)
 - NOP/command inhibit, [3-25](#)
 - precharge all, [3-21](#)
 - self-refresh, [3-44](#)
 - single precharge, [3-21](#)
- SDRAM controller registers, [A-25](#) to [A-30](#)
 - control (SDCTL), [A-25](#) to [A-28](#)
 - control status (SDSTAT), [A-29](#)
 - refresh rate control (SDRRC), [A-30](#)
- SENDZ (send zeros) bit, [12-31](#)
- SENDZ (send zeros) bit, [A-146](#)
- serial clock (SPORTx_CLK) pins, [7-11](#)
- serial communications, [14-7](#)
- serial inputs, [8-6](#)
- serial peripheral interface, *See* SPI
- setting up DMA on SPORT channels, [7-46](#)
- setup time, inputs, [17-36](#)
- shared memory
 - See also* external port bus arbitration, [3-48](#)
 - memory select (\overline{MSx}) pins, [3-50](#)
 - system design diagram, [3-47](#)
 - write (\overline{WR}) pin, [3-50](#)

Index

signal routing unit external miscellaneous (MISCAx) registers, [11-13](#)
signal routing unit *See* SRU, DAI
signal routing unit (SRU), [13-6](#)
signals
 bus grant $\overline{\text{HBG}}$, [3-54](#)
 bus request $\overline{\text{BRx}}$, [3-48](#), [3-53](#), [3-54](#)
 memory select $\overline{\text{MSx}}$, [3-54](#)
 PWM waveform generation and, [13-10](#)
 sensitivity in serial ports, [7-6](#)
 serial port, [7-8](#), [7-11](#)
 SPORT, [7-5](#)
 timer, [13-6](#)
single channel double frequency mode, [10-13](#)
single processor system example, [3-38](#)
slave mode DMA operations (SPI), [12-36](#)
slave mode operation, configure for, [12-33](#)
SPCTLx control bit comparison in four SPORT operation modes, [7-21](#)
SPCTLx control bits for left-justify mode, [7-25](#)
SPCTLx (serial port control) registers, [7-11](#), [7-12](#), [7-21](#)
S/PDIF
 See also S/PDIF bits; S/PDIF registers
 AAC compressed format, [10-18](#)
 AC-3 format, [10-18](#)
 audio standards, [10-14](#)
 biphase encoding, [10-5](#)
 block structure, [C-11](#)
 clock (SCLK) input, [10-5](#)
 compressed audio data, [10-17](#)
 DTS format, [10-18](#)
 frame sync (LRCLK) input, [10-5](#)
 MPEG-2 format, [10-18](#)
 non-linear audio data, [10-17](#)
 output routing, [10-8](#)
 pin descriptions, receiver, [10-4](#)

S/PDIF *(continued)*
 pin descriptions, transmitter, [8-3](#), [10-3](#)
 preambles, [C-16](#)
 programming guidelines, [10-6](#)
 serial clock input, [10-6](#)
 serial data (SDATA) input, [10-5](#)
 single-channel, double-frequency format, [10-13](#)
 subframe format, [C-13](#)
 timing, [10-4](#)
 two channel mode, [10-13](#)
S/PDIF bits
 biphase error (DIR_BIPHASEERROR), [A-128](#)
 channel status buffer enable (DIT_CHANBUF), [A-120](#)
 channel status byte 0 A (DIT_B0CHANL), [A-121](#)
 channel status byte 0 B (DIT_B0CHANR), [A-121](#)
 channel status byte 0 for subframe A (DIR_B0CHANL), [A-128](#)
 channel status byte 0 for subframe B (DIR_B0CHANR), [A-128](#)
 disable PLL (DIR_PLLDIS), [A-125](#), [A-126](#)
 frequency multiplier (DIT_FREQ), [A-120](#)
 lock error (DIR_LOCK), [A-125](#)
 lock receiver status (DIR_LOCK), [A-127](#)
 mute receiver (DIR_MUTE), [A-125](#)
 mute transmitter (DIT_MUTE), [A-120](#)
 non-audio frame mode channel 1 and 2 (DIR_NOAUDIOLR), [A-127](#)
 non-audio subframe mode channel 1 (DIR_NOAUDIOL), [A-127](#)
 parity biphase error (DIR_BIPHASE), [A-125](#)
 parity (DIR_PARITYERROR), [A-128](#)

S/PDIF bits *(continued)*

- select single channel double frequency mode channel (DIT_SCDF_LR), [A-120](#)
- serial data input format (DIT_SMODEIN), [A-120](#)
- single channel double frequency channel select (DIR_SCDF_LR), [A-125](#)
- stream disconnected (DIR_NOSTREAM), [A-128](#)
- transmit single channel double frequency enable (DIT_SCDF), [A-120](#), [A-125](#)
- transmitter enable (DIT_EN), [A-120](#)
- validity bit A (DIT_VALIDL), [A-120](#)
- validity bit B (DIT_VALIDR), [A-121](#)
- validity (DIR_VALID), [A-127](#)

S/PDIF registers

- channel A transmit status (SPDIF_TX_CHSTA), [A-121](#), [A-123](#)
- channel B transmit status (SPDIF_TX_CHSTB), [A-122](#), [A-123](#)
- left channel status for sub-frame A (DIRCHANL), [A-129](#)
- receiver status (DIRSTAT), [A-126](#)
- SRU control, [10-5](#), [10-8](#)
- transmit control (DITCTL), [10-6](#), [A-119](#)

SPDIF_TX_CHSTA (Sony/Philips digital interface channel status) register, [A-121](#), [A-123](#)

special IDP registers, [A-68](#)

SPEN_A (serial port channel A enable) bit, [A-73](#), [A-79](#)

SPI

- See also* SPI bits; SPI registers
- AD1855 DAC and, [12-11](#)
- address, chain pointer, [12-34](#)
- address, TCB, [12-37](#)
- block diagram, [12-8](#)

SPI *(continued)*

- booting, [17-13](#), [17-16](#)
- boot packing, [17-17](#)
- chained DMA, [2-11](#)
- chaining, DMA, [12-14](#), [12-20](#), [12-22](#), [12-26](#), [12-34](#), [12-36](#)
- change clock polarity, [12-23](#)
- changing configuration, [12-23](#)
- clock phase, [12-15](#)
- clock (SPICLK) pin, [12-14](#)
- clock (SPICLK) signal, [12-8](#)
- configuring and enabling, [12-34](#)
- DMA, switching from transmit to receive mode, [12-39](#)
- examples, timing, [12-17](#)
- examples, transfer protocol, [12-16](#)
- features, [12-2](#)
- functional description, [12-8](#)
- interconnections, master-slave, [12-3](#)
- interface signals, [12-3](#)
- interrupt, [12-20](#), [12-26](#), [12-35](#)
- loopback mode, [12-29](#)
- master boot mode, [17-13](#)
- master input slave output (MISOx) pins, [12-8](#)
- master mode, [12-30](#)
- master mode operation, configuring for, [12-30](#)
- master out slave in (MOSIx) pins, [12-8](#)
- master-slave interconnections, [12-3](#)
- operation, master mode, [12-34](#)
- operation, slave mode, [12-36](#)
- operations, [12-30](#)
- polarity, clock, [12-14](#), [12-23](#)
- receive data (RXSPI) buffer, [12-9](#), [12-31](#)
- registers, [A-144](#)
- send zero (SENDZ) bit, [12-31](#)
- slave boot mode, [17-16](#)
- slave mode, [12-21](#), [12-32](#), [12-33](#)
- SPIDS pin, [12-33](#), [12-36](#)

Index

SPI *(continued)*

- switching from receive to transmit mode, [12-39](#), [12-40](#)
 - system, configuring and enabling bits, [12-34](#), [A-144](#)
 - transfer formats, [12-14](#)
 - transmit data (TXSPI) buffer, [12-9](#)
 - transmit underrun error (SPIUNF) bit, [12-26](#), [12-42](#), [12-43](#), [A-152](#)
 - TXFLSH (flush transmit buffer) bit, [12-39](#), [A-150](#)
- ## SPI bits
- chained DMA enable (SPICHEN_A and SPICHEN_B), [12-34](#), [A-152](#)
 - chain loading status (SPICHS), [A-153](#)
 - clock phase (CPHASE), [A-148](#)
 - clock polarity (CLKPL), [A-148](#)
 - device select enable (DSxEN), [12-34](#)
 - DMA interrupt enable (INTEN), [12-26](#)
 - enable interrupt on error (INTERR), [12-26](#)
 - enable (SPIEN), [A-149](#)
 - FIFO clear (FIFOFLSH), [A-152](#)
 - flush receive buffer (RXFLSH), [12-39](#), [12-41](#), [A-150](#)
 - flush transmit buffer (TXFLSH), [A-150](#)
 - get more data (GM), [12-31](#), [A-146](#)
 - input slave select enable (ISSEN), [12-28](#)
 - input slave select (ISSEN), [A-146](#)
 - internal loop back (ILPBK), [A-150](#)
 - low priority interrupt (SPILI), [12-26](#)
 - master select (SPIMS), [A-148](#)
 - MISO disable (DMISO), [A-147](#)
 - mode fault error (MME), [12-27](#), [12-28](#)
 - most significant byte first (MSBF), [A-147](#)
 - open drain output select (OPD), [A-148](#)
 - packing enable (PACKEN), [A-149](#)
 - program controlled interrupt bit (PCI), [12-14](#)

SPI bits *(continued)*

- receive overflow error (SPIOVF), [12-26](#), [12-42](#), [12-43](#)
 - seamless transfer (SMLS), [A-150](#)
 - send zero (SENDZ), [A-146](#)
 - SENDZ (send zeros) bit, [12-31](#)
 - sign extend (SGN), [A-149](#)
 - word length (WL), [A-147](#)
- ## SPICHEN_A and SPICHEN_B (SPI DMA chaining enable) bits, [12-34](#), [12-36](#), [A-76](#), [A-80](#), [A-85](#)
- ## SPICLK (SPI clock) pins, [12-14](#)
- ## SPICLK (SPI clock) signal, [12-8](#)
- ## SPICTL (SPI port control) registers, [A-144](#)
- ## SPIDMAC (SPI DMA control) register, [12-20](#), [A-151](#)
- ## SPIDS (SPI device select) pin, [12-14](#)
- ## SPIDS status, *See* ISSS bit
- ## SPI general operations, [12-6](#)
- ## SPI interrupts, [12-25](#)
- ## SPILI (SPI low priority interrupt) bit, [12-26](#)
- ## SPI master mode operation, [12-30](#)
- ## SPIOVF (SPI receive overflow error) bit, [12-26](#), [12-42](#), [12-43](#)
- ## SPI registers
- DMA configuration (SPIDMAC), [12-20](#), [12-34](#), [12-36](#), [12-38](#), [12-39](#), [A-151](#)
 - flag (SPIFLGx), [A-156](#)
 - interrupt latch (IRPTL), [12-26](#)
 - interrupt latch/mask (LIRPTL), [12-26](#)
 - interrupt (LIRPTL), [12-26](#)
 - receive buffer (RXSPI), [2-8](#)
 - receive control (SPICTL, SPICTLB), [A-144](#)
 - RXSR (SPI receive shift), [12-8](#)
 - SPIBAUD (baud rate) register, [A-153](#)
 - status (SPISTAT), [12-28](#), [12-38](#), [12-41](#), [A-153](#)

SPI registers *(continued)*status (SPISTAT, SPISTATB), [A-153](#)transmit buffer (TXSPI), [12-31](#), [A-153](#)TXSR (SPI transmit shift), [12-8](#)SPI slave mode operation, [12-33](#)

SPISTAT, SPISTATB (SPI status)

registers, [A-153](#)

SPIUNF (SPI transmit underrun error) bit,

[12-26](#), [12-42](#), [12-43](#)

SPORT

interrupts, [7-49](#)SPORT bits, [7-32](#)B channels enable (MCEB), [A-90](#)chained DMA enable (SCHEN), [7-46](#),[7-47](#), [7-57](#)

chained DMA enable (SPICHEN),

[A-76](#), [A-80](#), [A-85](#)channel A enable (SPEN_A), [A-73](#), [A-79](#)

channel error status (ROVF_A or

TUVF_A), [7-16](#), [A-78](#), [A-82](#)clock, internal clock (ICLK), MSTR (I²Smode only), [A-74](#)clock, MSTR (I²S mode only), [A-80](#),[A-84](#)clock rising edge select (CKRE), [7-8](#)control bit comparison, [7-21](#)current channel selected (CHNL), [A-90](#)

data independent transmit/receive frame

sync (DIFS), [A-75](#), [A-80](#)

data independent transmit/receive

framesync (DIFS), [7-42](#)data type (DTYPE), [7-21](#)

DMA chaining status (DMACHSxy),

[A-91](#)DMA enable (SDEN), [A-76](#), [A-80](#), [A-85](#)DMA status (DMASxy), [A-90](#), [A-91](#)DXS_B (data buffer status), [A-78](#), [A-82](#),[A-87](#)frame on rising frame sync (FRFS), [7-29](#),[7-30](#)SPORT bits *(continued)*FS both enable (FS_BOTH), [A-76](#)internal frame sync select (IFS), [A-75](#),[A-85](#)internal serial clock (ICLK), [7-8](#)late frame sync (LAFS), [A-75](#), [A-80](#)loopback mode (SPL), [A-90](#)multichannel frame delay (MFD), [A-89](#)

multichannel mode enable (MCEA),

[A-89](#)number of channels (NCH), [7-35](#)

number of multichannel slots (NCH),

[A-89](#)operation mode (OPMODE), [7-19](#),[7-21](#), [7-22](#), [7-25](#), [7-29](#), [7-30](#)

program controlled interrupt bit (PCI),

[7-48](#)

receive underflow status (ROVF_A or

TUVF_A), [A-78](#), [A-82](#)serial word length (SLEN), [7-25](#), [7-29](#),[7-30](#)

SPORT modes

(I²S), [7-20](#)I²S (Tx/Rx on left channel first), [7-23](#)left-justified, [7-23](#), [7-28](#), [C-5](#)loopback, [7-54](#)multichannel, [7-31](#)standard DSP, [7-23](#), [7-24](#), [C-2](#)SPORT registers, [A-70](#) to [A-95](#)channel selection, [7-38](#)control, [7-21](#)control (SPCTLx), [7-11](#), [7-12](#), [7-21](#)divisor (DIVx), [7-11](#)

multichannel control (SPMCTLxy),

[7-22](#), [7-32](#), [7-54](#)receive buffer (RXSPx), [7-14](#), [7-15](#), [7-40](#),[7-41](#), [C-4](#)receive compand (MRxCCSx), [A-93](#)receive select (MRxCSx), [A-92](#)SPCTLx (serial port control), [A-71](#)

Index

SPORT registers *(continued)*
transmit buffer (TXSPx), 7-14, 7-15,
7-40, C-4
transmit compand (MTxCSx,
MTxCCSx), A-92

SPORTs, 7-60
See also SPORT bits, modes, registers
128-channel TDM, 7-3
address, DMA, 7-46
address, TCB and, 7-56
buffer hang disable (BHD) bit, 7-54
buffers, data, 7-40
chained DMA, 2-11
chain insertion mode (DMA), 7-48
channel number (quantity) select (NCH
bit), 7-35
clock divisor equation, 7-9
clock frequency equation, 7-9
clock (SCLKx) pins, 7-11
clock signal options, 7-8 to 7-10
companding and data type bit (DTYPE),
7-14
companding (compressing/expanding),
7-3
configuring frame sync signals, 7-12
configuring standard DSP serial mode,
7-24
control bit comparison, 7-21
core hang, 7-42
data type, sign-extend, 7-12
data type, zero-fill, 7-12
data type bit (DTYPE), 7-21
debugging, A-90
divisor (DIVx) register, 7-8, 7-18, 7-25,
7-28
DMA chaining, 7-47
DMA channels, 7-46
duplex, full, 7-11
enabling B channels, A-90

SPORTs *(continued)*
equation
frame sync frequency, 7-10
examples, normal vs. alternate framing,
7-28
features, 7-2
finding currently selected channel, A-90
flag pins, 7-12
FLAGx pins, 7-12
framed and unframed data, 7-26
framed vs. unframed data example, 7-28
frame sync and serial word length, 7-10
frame sync delay, 7-32
full-duplex operation, 7-11
input/output (FLAGx) pins, 7-12
internal clock selection, 7-8
interrupts, 7-46, 7-50
I/O processor bus and, 7-48
latency in writes, 7-55
left-justified mode control bits, 7-29
loopback mode, 7-54
masking interrupts, 7-50
master mode enable, 7-30
operation modes, changing, 7-21
operation modes, listed, 7-20
operation modes, standard DSP serial,
7-24, C-2
packing enable (PACK) bit, 7-21, 7-46,
7-50
pairing, 7-31, 7-33
receive buffers, 7-41
serial clock pins, 7-11
serial word length and frame sync, 7-10
setting frame sync rates, 7-28
signal sensitivity, 7-6
SPORTx_DA and SPORTx_DB
channel data signal, 7-11
SPORTx_FS (serial port frame sync)
pins, 7-12
transmit buffers, 7-41

SPORTs *(continued)*

transmit underflow status (TUVF_A)
bit, [A-78](#), [A-82](#)

transmit valid data signal
(SPORTx_TDV_0), [7-33](#)

Tx/Rx on FS rising edge, [7-23](#)

using with SRU, [7-5](#)

warning, [7-42](#)

word length, [7-10](#)

SPTRAN (serial port data direction
control) bit, [A-77](#), [A-81](#), [A-86](#)

SRC

block diagram, [9-6](#)

clocking, [9-12](#), [C-7](#)

control (SRCCTLx) register, [A-105](#)

frame sync signal, [9-4](#)

interrupts, [9-16](#)

mute (SRCMUTE) register, [A-108](#)

ratio (SRCRAT) register, [A-109](#)

right justified mode, [9-14](#)

right-justified mode, [9-9](#)

right-justified mode, timing, [9-9](#)

time division multiplexing mode, [9-14](#),
[C-8](#)

SRC bits

auto mute (SRC0_AUTO_MUTE),
[A-105](#)

bypass (SRC0_BYPASS), [A-105](#)

de-emphasis (SRC0_DEEMPHASIS),
[A-105](#)

dither select (SRC0_DITHER), [A-105](#)

enable (SRC0_ENABLE), [A-106](#)

hard mute (SRC0_HARD_MUTE),
[A-105](#)

matched phase select

(SRC0_MPHASE), [A-106](#), [A-108](#)

serial input format (SRC0_SMODEIN),
[A-105](#)

SRC bits *(continued)*

serial output format

(SRC0_SMODEOUT), [A-106](#)

soft mute (SRC0_SOFTMUTE), [A-105](#)

word length, output (SRC0_LENOUT),
[A-106](#)

SRU

bidirectional pin buffer, [6-14](#)

buffers, [6-14](#)

connecting peripherals with, [6-16](#)

connecting through, [6-20](#)

frame sync routing control (SRU_FSx)
registers, [A-51](#)

group A (clock) signals, [6-24](#), [A-130](#)

group E (miscellaneous) signals, [A-61](#) to
[A-63](#)

inputs, [6-16](#)

outputs, [6-16](#)

register use of, [6-20](#)

serial ports and, [7-5](#)

signal groups, [6-18](#) to [6-19](#)

signal groups, defined, [6-16](#), [6-17](#)

signal sources, clock, [A-41](#)

signal sources, frame sync, [A-51](#)

signal sources, miscellaneous, [A-61](#)

signal sources, pin signal, [A-55](#)

SPORT signal connections, [7-5](#)

SRU2

group B (pin assignment) signals, [A-134](#)

group C (pin enable) signals, [A-138](#)

SRU registers

clock (SRU_CLKx), [A-41](#)

frame sync (SRU_FSx), [A-51](#)

miscellaneous (SRU_EXT_MISCx),
[A-61](#)

pin assignment (SRU_PINx) registers
(group D), [A-55](#)

pin enable (SRU_PINENx) registers,
[A-64](#)

pin signal (SRU_PINx), [A-55](#)

Index

SRU registers *(continued)*
SRU_DATx (SRU data) registers, [A-46](#)
SRU_EXT_MISCx (SRU external miscellaneous) registers, [A-61](#)
SRU_FSx (SRU frame sync routing control) registers, [A-51](#)
SRU_PINENx (SRU pin buffer enable) registers, [A-64](#)
SRU_PINGx_STAT (ping-pong DMA status) register, [A-102](#), [A-103](#)
SRU_PINx (pin signal assignment) registers, [A-55](#)
standard DSP serial mode, [7-24](#), [C-2](#)
starting an interrupt driven transfer, [8-29](#), [8-30](#)
status registers, DMA, [2-32](#)
STROBEA (one shot frame sync A) bit, [11-13](#), [A-115](#)
STROBEB (one shot frame sync B) bit, [11-13](#), [A-115](#)
strobe period, [11-13](#)
supervisory circuits, [17-41](#)
switching from receive to transmit DMA, [12-40](#)
switching from transmit to receive DMA, [12-38](#)
synchronization with the external clock, [11-20](#)
synchronizing frame sync output, [11-20](#)
SYSCTL register
external port data pin mode select (EPDATA) bits, [A-5](#)
interrupt request enable (IRQxEN) bits, [A-5](#)
memory select (MSEN) bit, [A-5](#)
pulse width modulation select (PWMx) bits, [A-6](#)
rotating priority bus arbitration (RBPR) bit, [2-37](#)

SYSCTL register *(continued)*
timer (flag) expired mode (TMREXPEN) bit, [A-5](#)
SYSCTL (system control) register, [A-4](#)
system, [17-33](#)
system control register. *See* SYSCTL register
system design
baud rate, init value, [17-14](#)
bypass capacitors, [17-37](#)
clock distribution, [17-33](#)
conditioning input signals, [17-33](#)
crosstalk, [17-37](#)
decoupling capacitors, [17-37](#)
designing for high frequency operation, [17-33](#)
generators, reset, [17-42](#)
ground plane, [17-37](#)
hold time, inputs, [17-36](#)
input setup and hold time, [17-36](#)
input signal conditioning, [17-33](#)
latchup, [17-33](#)
latency, input synchronization, [17-29](#)
pin descriptions, [16-15](#), [17-2](#)
plane, ground, [17-37](#)
PLL start-up, [16-3](#)
power options, [16-6](#), [16-7](#), [16-11](#)
power supply, monitor and reset generator, [17-42](#)
power-up, [16-3](#)
recommendations and suggestions, [17-37](#)
RESET pin, [17-34](#)
shared memory system diagram, [3-47](#)
VCO encodings, [16-5](#)

T

TCB, [2-11](#) to [2-16](#), [2-27](#)
TCB chain loading, [2-10](#)
technical support, [xlix](#)

- test
 - loopback, SPI, [A-150](#)
- test mode
 - DAI use in, [6-10](#), [6-40](#)
 - loopback, SPI, [12-29](#), [A-150](#)
 - SPI, [12-28](#)
 - SPORT, [7-54](#), [7-60](#), [13-19](#), [15-18](#)
 - system, [17-33](#)
- THR register empty (THRE) flag, [14-11](#), [14-14](#)
- time division multiplexed (TDM) mode, [7-31](#), [9-12](#), [C-7](#)
- timeout, bus mastership, [3-57](#)
- timer
 - configuring, [A-183](#)
 - mode of operation, [A-183](#)
- timer registers, [A-182](#)
 - timer control (TMxCTL), [A-183](#)
 - timer status (TMxSTAT), [A-184](#)
- timers, UART, [14-6](#)
- timer *See* peripheral timers, core timer
- timing
 - external memory accesses, [3-5](#)
 - kernel boot, [17-22](#)
 - PWM, [5-7](#), [5-8](#)
 - S/PDIF, [10-4](#)
 - SPI clock, [12-17](#)
 - SPI slave, [12-17](#)
 - SPI transfer protocol, [12-16](#)
 - SPORT bits, [7-24](#)
 - SPORT framed vs. unframed data, [7-28](#)
 - SPORT normal vs. alternate framing, [7-28](#)
 - SRC, [9-9](#)
- TIMOD (transfer initiation mode) bit, [12-26](#), [12-31](#)
- TMSTAT (peripheral timer global status and control) register, [13-4](#)
- TMxCNT (peripheral timer word count) registers, [13-4](#), [13-6](#)
- TMxCTL (peripheral timer control) registers, [13-6](#)
- TMxCTL (timer control) registers, [A-183](#)
- TMxPRD (peripheral timer period) registers, [13-4](#)
- TMxSTAT (timer global status and control) register, [A-184](#)
- TMxW (peripheral timer width) registers, [13-5](#)
- TMxW (peripheral timer word pulse width) registers, [13-7](#)
- tools, development, [1-6](#)
- T_PRDHx (timer period) registers, [13-4](#), [13-7](#)
- transfer control block, *See* DMA TCB
- transfer control block *See* DMA TCB
- transfer direction, external port, [2-19](#)
- transfer initiation and interrupt (TIMOD) mode, [12-26](#)
- transmit and receive data buffers (TXSPxA/B, RXSPxA/B), [7-41](#)
- transmit and receive SPORT data buffers (TXSPxA/B, RXSPxA/B), [7-41](#)
- transmit data (TXSPI) buffer, [12-9](#)
- transmit shift (TXSR) register, [12-8](#)
- TUVF_A (channel error status) bit, [A-78](#), [A-82](#)
- TWI controller
 - architecture, [15-6](#)
 - block diagram, [15-7](#)
 - bus arbitration, [15-9](#)
 - call address, [15-14](#)
 - clocking, [15-8](#)
 - error, [15-11](#), [15-20](#), [15-24](#), [A-180](#)
 - fast mode, setting, [15-15](#)
 - programming model, [15-19](#)
 - receive error, [A-180](#)
 - start and stop conditions, [15-10](#)

Index

TWI controller *(continued)*

transferring data, [15-8](#)
transmit error, [A-180](#)

TWI controller bits

address not acknowledged (TWIANAK),
[A-174](#)

buffer write error (TWIWERR), [A-175](#)

clock high (TWICLKHI), [A-168](#)

clock low (TWICLKLOW), [A-168](#)

data not acknowledged (TWIDNAK),
[A-174](#)

data transfer count (TWIDCNT), [A-172](#)

fast mode (TWIFAST), [A-171](#)

general call enable (TWIGCE), [A-169](#)

issue stop condition (TWISTOP), [A-172](#)

lost arbitration (TWILOST), [A-174](#)

master address length (TWIMLEN),
[A-171](#)

master mode enable (TWIMEN), [A-171](#)

master transfer direction (TWIMDIR),
[A-171](#)

master transfer in progress
(TWIMPROG), [A-174](#)

not acknowledged (TWINAK), [A-169](#)

repeat START (TWIRSTART), [A-172](#)

serial clock override (TWISCLOVR),
[A-172](#)

serial clock sense (TWISCLSEN), [A-176](#)

serial data override (TWISDAOVR),
[A-172](#)

serial data sense (TWISDASEN), [A-175](#)

slave address length (TWISLEN), [A-169](#)

slave enable (TWISEN), [A-169](#)

slave transmit data valid (TWIDVAL),
[A-169](#)

TWI controller registers

clock divider (TWIDIV), [A-168](#)

RXTWI16 (16-bit receive FIFO)
register, [15-14](#)

RXTWI8 (8-bit receive FIFO), [15-13](#)

TWI controller registers *(continued)*

TWIMADDR (master mode address),
[A-173](#)

TWIMCTL (master mode control),
[A-170](#)

TWIMSTAT (master mode status),
[A-173](#)

TWISADDR (slave mode address),
[A-170](#)

TWISCTL (slave mode control), [A-168](#)

TWISSTAT (slave mode status), [A-170](#)

TXTWI16 (16-bit transmit FIFO),
[15-12](#)

TXTWI8 (8-bit transmit FIFO), [15-12](#)

two channel mode (S/PDIF), [10-13](#)

TXFLSH (flush transmit buffer) bit, [12-39](#),
[A-150](#)

TXS_A (data buffer channel B status) bit,
[A-78](#), [A-82](#), [A-87](#)

TXSPI, TXSPIB (SPI transmit buffer)
registers, [A-153](#)

TXSPI (SPI transmit buffer) register, [2-8](#),
[12-19](#), [12-31](#)

TXSPx (serial port transmit buffer)
registers, [2-8](#)

TXSR (SPI transmit shift) register, [12-8](#)

TX_UACEN (DMA transmit buffer
enable) bit, [14-5](#)

U

UART, [14-1](#)

baud rate, [14-11](#), [14-12](#)

baud rate examples, [14-5](#)

block diagram, [14-7](#)

chained DMA, [2-12](#), [14-15](#)

core transfers, [14-13](#)

data ready flag, [14-14](#)

data word, [14-11](#)

divisor, [14-4](#), [A-163](#)

divisor reset, [14-5](#)

- UART *(continued)*
- DMA transfers, [14-14](#)
 - sampling clock period, [14-13](#)
 - sampling point, [14-13](#)
 - SRU use with, [14-3](#)
 - standard, [14-1](#)
 - timers, [14-6](#)
 - word length select, [A-158](#)
- UART bits
- 9-bit RX enable (RX9), [A-164](#)
 - 9-bit TX enable (TX9), [A-164](#)
 - address detect enable (UARTAEN), [A-164](#)
 - DMA TX/RX control, [A-165](#)
 - DMA TX/RX status, [A-166](#)
 - enable receive buffer full interrupt (UARTRBFIE), [A-160](#)
 - enable transmit buffer empty interrupt (UARTTBEIE), [A-160](#)
 - interrupt enable, [A-161](#)
 - pack data, [14-8](#)
 - packing enable (PACK), [A-164](#)
 - pin status (UARTPSTx), [A-164](#)
 - program controlled interrupt bit (PCI), [14-24](#)
 - synch data packing in RX (UARTPKSYN), [A-164](#)
 - THR register empty (UARTTHRE), [A-159](#)
 - UARTNOINT (pending interrupt), [A-162](#)
 - UARTSTAT (interrupt), [A-162](#)
- UART registers
- divisor latch register (UARTxDLL), [14-4](#), [A-163](#)
 - divisor latch (UARTxDLH), [14-4](#), [A-163](#)
 - interrupt enable register (UARTxIER), [A-160](#)
- UART registers *(continued)*
- interrupt identification register (UARTxIIR), [A-161](#)
 - line control register (UARTxLCR), [A-157](#)
 - line status register (UARTxLSR), [A-159](#)
 - receive buffer register (UARTxRBR), [14-12](#)
 - transmit holding (UARTxTHR), [14-11](#)
 - transmit shift register (UART_TSR), [14-11](#)
 - UARTxDLH (divisor latch register), [14-4](#), [A-163](#)
 - UARTxDLL (divisor latch register), [14-4](#), [A-163](#)
 - UARTxIER (interrupt enable register), [A-160](#)
 - UARTxIIR (interrupt identification register), [A-161](#)
 - UARTxLCR (line control register), [A-157](#)
 - UARTxLSR (line status register), [A-159](#)
 - UARTxRBR (receive buffer register), [14-12](#)
 - UARTxTHR (transmit holding register), [14-11](#)
 - UARTxTSR (transmit shift register), [14-11](#)
- V
- VCO
- bypass clock, [16-7](#)
 - clock, [16-5](#)
 - examples, clock management, [16-13](#)
 - output clock, [16-5](#)
- W
- wait states, enabling (WS bit), [A-23](#)

Index

warning

DMA transfers, [2-23](#)

I/O processor, [2-23](#)

watchdog function, timer, [13-19](#)

WIDTH_CAP (width capture) mode, [13-2](#),
[13-13](#)

word length, [7-10](#)

word length (SLEN) bits, [7-29](#), [7-30](#)

word packing enable (packing 16-bit to
32-bit words), [A-74](#), [A-80](#), [A-84](#)

write-1-to-clear bit description (W1C), [A-4](#)

write-only bit description (WO), [A-4](#)

write-only-to-clear bit description (WOC),
[A-4](#)

write ($\overline{\text{WR}}$) pin, [3-50](#)