

Precision Monolithics Inc.

### FEATURES

- **Fast Settling** ..... 225nsec (8 Bits), 375nsec (10 Bits)
- **Stable** ..... Tempcos to  $\pm 15\text{ppm}/^\circ\text{C}$  Max
- **Commercial, Industrial and Military Models Available**
- **TTL Compatible Logic Inputs**
- **Wide Supply Range** .....  $\pm 6\text{V}$  to  $\pm 18\text{V}$

### GENERAL DESCRIPTION

The DAC-100 is a complete 10-bit resolution digital-to-analog converter constructed on two monolithic chips in a single 16-pin DIP. Featuring excellent linearity vs. temperature performance, the DAC-100 includes a low tempco voltage reference, ten current source/switches and a high stability thin-film R-2R ladder network. Maximum application flexibility is provided by the fast current output, matched bipolar offset and feedback resistors. Resistors are included for use with an external op amp for voltage output applications.

Although all units have 10-bit resolution, a wide choice of linearity and temperature coefficient options are provided to allow price/performance optimization.

The small size, wide operating temperature range, and high reliability construction make the DAC-100 ideal for aerospace applications. Other applications include use in servo-positioning systems, X-Y plotters, CRT displays, programmable power supplies, analog meter movement drivers, waveform generators and high speed analog-to-digital converters.

### PIN CONNECTIONS

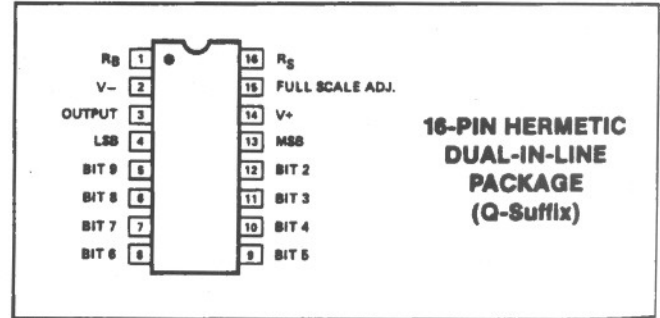

### ORDERING INFORMATION†

N.L.* %FS MAX	TEMPCO* ppm/°C MAX	MILITARY TEMPERATURE		INDUSTRIAL TEMPERATURE		COMMERCIAL TEMPERATURE	
		$V_O = \pm 5\text{V}/10\text{V}$	$V_O = \pm 2.5\text{V}/5\text{V}$	$V_O = \pm 5\text{V}/10\text{V}$	$V_O = \pm 2.5\text{V}/5\text{V}$	$V_O = \pm 5\text{V}/10\text{V}$	$V_O = \pm 2.5\text{V}/5\text{V}$
$\pm 0.05$	$\pm 15$	—	—	DAC100AAQ7	DAC100AAQ8	—	—
$\pm 0.05$	$\pm 30$	—	—	DAC100ABQ7	DAC100ABQ8	—	—
$\pm 0.05$	$\pm 60$	✓DAC100ACQ5/883	✓DAC100ACQ6/883	DAC100ACQ7	DAC100ACQ8	DAC100ACQ3	DAC100ACQ4
$\pm 0.10$	$\pm 30$	DAC100BBQ5/883	—	DAC100BBQ7	✓DAC100BBQ8	—	—
$\pm 0.10$	$\pm 60$	DAC100BCQ5/883	—	DAC100BCQ7	—	DAC100BCQ3	✓DAC100BCQ4
$\pm 0.10$	$\pm 120$	—	—	—	—	—	—
$\pm 0.20$	$\pm 60$	DAC100CCQ5/883	DAC100CCQ6/883	DAC100CCQ7	—	✓DAC100CCQ3	✓DAC100CCQ4
$\pm 0.20$	$\pm 120$	—	—	—	—	—	—
$\pm 0.30$	$\pm 120$	—	—	DAC100DDQ7	—	DAC100DDQ3	—

\* Part number construction: The 1st letter following DAC-100 (A-D) refers to the nonlinearity specification; the 2nd letter (A-D) refers to the full-scale tempco; the letter Q refers to the package; and the end numeral indicates the output voltage and temperature.

† Burn-in is available on commercial and industrial temperature range parts in cerdip, plastic dip, and TO-can packages. For ordering information, see 1988 Data Book, Section 2.

### SIMPLIFIED SCHEMATIC

✓ = Currently available as of 5/97.

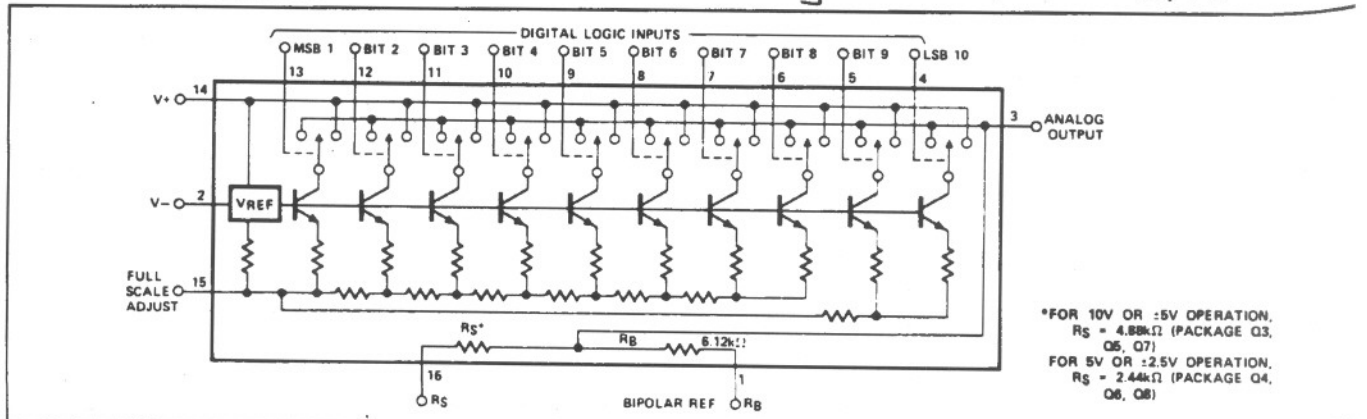

\*FOR 10V OR  $\pm 5\text{V}$  OPERATION,  
RS = 4.88kΩ (PACKAGE Q3,  
Q5, Q7)  
FOR 5V OR  $\pm 2.5\text{V}$  OPERATION,  
RS = 2.44kΩ (PACKAGE Q4,  
Q6, Q8)

**ABSOLUTE MAXIMUM RATINGS** (Note 2)

V+ Supply to V- Supply	0 to +36V
V+ Supply to Output	0 to +18V
V- Supply to Output	0 to -18V
Logic Inputs to Output	-1V to +6V
Power Dissipation (Note 1)	500mW
Operating Temperature Range Q3, Q4	0° C to +70° C
Q5, Q6, Q7, Q8	-55° C to +125° C

DICE Junction Temperature	-25° C to +150° C
Storage Temperature Range	-65° C to +150° C
Lead Temperature (Soldering, 60 sec)	+300° C

**NOTES:**

1. Rating applies to ambient temperature of 100° C. Above 100° C, derate at 10mW/° C.
2. Ratings apply to DICE and packaged parts, unless otherwise noted.

**ELECTRICAL CHARACTERISTICS** at  $V_S = \pm 15V$ ,  $-25^\circ C \leq T_A \leq +85^\circ C$  for Q7 and Q8 devices;  $0^\circ C \leq T_A \leq +70^\circ C$  for Q3 and Q4;  $-55^\circ C \leq T_A \leq +125^\circ C$  for Q5 and Q6 devices, unless otherwise noted.

PARAMETER	SYMBOL	CONDITIONS	DAC-100	MIN	TYP	MAX	UNITS
Resolution				10	—	—	Bits
Nonlinearity (For nonlinearity/tempco combinations, see Ordering Information)	NL	( $\pm 1/2$ LSB — 10 bits)	A—	—	—	$\pm 0.05$	%FS
		( $\pm 1/2$ LSB — 9 bits)	B—	—	—	$\pm 0.1$	
		( $\pm 1/2$ LSB — 8 bits)	C—	—	—	$\pm 0.2$	
		( $\pm 3/4$ LSB — 8 bits)	D—	—	—	$\pm 0.3$	
Full-Scale Tempco (See Full-Scale Test Circuit)	T <sub>C</sub>		—A	—	—	$\pm 15$	ppm/°C
			—B	—	—	$\pm 30$	
			—C	—	—	$\pm 60$	
			—D	—	—	$\pm 120$	
Settling Time T <sub>A</sub> = 25° C	t <sub>S</sub>	to $\pm 0.05\%$ FS	ALL	—	—	375	ns
		to $\pm 0.1\%$ FS	ALL	—	—	300	
		to $\pm 0.2\%$ FS	ALL	—	—	225	
		to $\pm 0.4\%$ FS	ALL	—	—	150	
		to $\pm 0.8\%$ FS	ALL	—	—	100	
Full-Range Output Voltage (Limits guarantee adjustability to exact 10.0 (5.0)V with a 200Ω Trimpot® between Adjust and V-)	V <sub>FR</sub>	Connect FS Adjust to V- 10V Models (Q3, Q5, Q7) (See Full-Scale Test Circuit) 5V Models (Q4, Q6, Q8) V <sub>IN</sub> = 0.7V (See Basic Unipolar Voltage Output Circuit)		10	—	11.1	V
				5	—	5.55	
Zero-Scale Output Voltage	V <sub>ZS</sub>	V <sub>IN</sub> = 2.1V	ALL	—	—	0.013	%FS
Logic Inputs: High	V <sub>INH</sub>	Measured with respect to output pin	ALL	2.1	—	—	V
Logic Inputs: Low	V <sub>INL</sub>	Measured with respect to output pin	ALL	—	—	0.7	V
Logic Input Current, Each Input	I <sub>IN</sub>	V <sub>IN</sub> = 0 to +6V	ALL	—	—	5	μA
Logic Input Resistance	R <sub>IN</sub>	V <sub>IN</sub> = 0 to +6V	ALL	—	3	—	mΩ
Logic Input Capacitance	C <sub>IN</sub>		ALL	—	2	—	pF
Output Resistance	R <sub>O</sub>		ALL	—	500	—	kΩ
Output Capacitance	C <sub>O</sub>		ALL	—	13	—	pF
Applied Power Supplies: V+			ALL	+6	—	+18	V
Applied Power Supplies: V-			ALL	-6	—	-18	V
Power Supply Sensitivity	P <sub>SS</sub>	V <sub>S</sub> = $\pm 6V$ to $\pm 18V$	ALL	—	—	$\pm 0.10$	% per Volt
Power Consumption	P <sub>D</sub>	V <sub>S</sub> = $\pm 15V$	Q3, Q4	—	200	300	mW
		V <sub>S</sub> = $\pm 6V$	Q3, Q4	—	80	—	
		V <sub>S</sub> = $\pm 15V$	Q5, Q6, Q7, Q8	—	200	250	
Positive Supply Current	I+	V <sub>S</sub> = +15V	Q3, Q4	—	—	10	mA
		V <sub>S</sub> = +15V	Q5, Q6, Q7, Q8	—	—	8.33	
Negative Supply Current	I-	V <sub>S</sub> = -15V	Q3, Q4	—	—	-10	mA
		V <sub>S</sub> = -15V	Q5, Q6, Q7, Q8	—	—	-8.33	

**DICE CHARACTERISTICS**

**DAR-01**

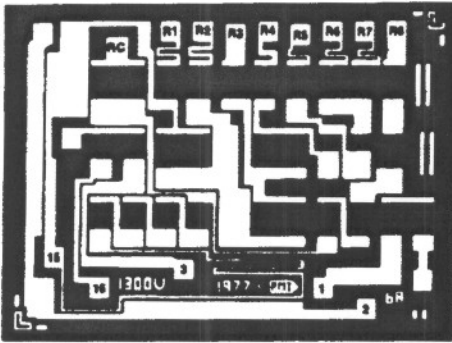

**DIE SIZE .090 x .064 inch, 5760 sq. mils  
(2.286 x 1.701 mm, 3.888 sq. mm)**

- 1.  $R_B$
- 2.  $V^-$
- 3. OUTPUT
- 15. FULL-SCALE ADJ
- 16.  $R_S$

R — Pads are connected to similarly marked pads on DAI-01

Note: Pads 4 — 14, See DAI-01

**DAI-01**

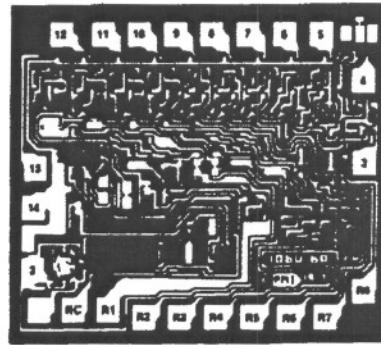

**DIE SIZE 0.080 x 0.067 inch, 5,360 sq. mils  
(2.032 x 1.702 mm, 3.458 sq. mm)**

- 2.  $V^-$
- 3. OUTPUT
- 4. BIT 10 (LSB)
- 5. BIT 9
- 6. BIT 8
- 7. BIT 7
- 8. BIT 6
- 9. BIT 5
- 10. BIT 4
- 11. BIT 3
- 12. BIT 2
- 13. BIT 1 (MSB)
- 14.  $V^+$

R — Pads are connected to similarly marked pads on DAR-01

Note: Pads 1, 2, 15, 16, See DAR-01

These die versions are available on special order; contact your PMI sales office.

**WAFER TEST LIMITS** at  $T_A = 25^\circ\text{C}$  for the R-2R Ladder Network comprised of R1—R8, R12, R23, R34, R45 and R56 when connected to an ideal DAI-01, unless otherwise noted.

PARAMETER	CONDITIONS	DAR-01-N			DAR-01-G			UNITS
		MIN	TYP	MAX	MIN	TYP	MAX	
Nonlinearity	$VR1 = 3.2V$	—	—	$\pm 0.035$	—	—	$\pm 0.05$	%

**WAFER TEST LIMITS** at  $T_A = 25^\circ\text{C}$ ,  $VR1 = 3.2V$ , unless otherwise noted.

PARAMETER	CONDITIONS	DAR-01			UNITS
		MIN	TYP	MAX	
Resistance R1	Absolute Measurement	2.56	—	3.84	k $\Omega$
Ratio RC1 to R1	Ideal = 1.00503 to 1	-1	—	+1	%
Ratio R1 to RS1	Ideal = 1.29959 to 1	-1	—	+1	%
Ratio R1 to RS2	Ideal = 1.29959 to 1	-1	—	+1	%
Ratio RB to R1	Ideal = 1.92211 to 1	-1	—	+1	%

**NOTE:**

Electrical tests are performed at water probe to the limits shown. Due to variations in assembly methods and normal yield loss, yield after packaging is not guaranteed for standard product dice. Consult factory to negotiate specifications based on dice lot qualification through sample lot assembly and testing.

# DAC-100

## TYPICAL ELECTRICAL CHARACTERISTICS in common to all grades.

PARAMETER	CONDITIONS	DAR-01			UNITS
		MIN	TYP	MAX	
Absolute Temperature Coefficient	All Resistors	—	±180	—	ppm/°C
Tracking Temperature Coefficient	All Resistors with Respect to R1	—	3	—	ppm/°C

## WAFER TEST LIMITS at $T_A = 25^\circ\text{C}$ when connected to an ideal DAR-01, unless otherwise noted.

PARAMETER	SYMBOL	CONDITIONS	DAI-01-N			DAI-01-G			UNITS
			MIN	TYP	MAX	MIN	TYP	MAX	
Nonlinearity	NL	$V_S = \pm 15\text{V}$	—	—	±0.05	—	—	±0.1	%
Internal Reference Voltage	$V_{MCR}$	$V_S = \pm 15\text{V}$	8.8	—	6.900	6.6	—	6.900	V

## WAFER TEST LIMITS at $V_S = \pm 15\text{V}$ , $T_A = 25^\circ\text{C}$ when connected to an ideal DAR-01, unless otherwise noted.

PARAMETER	CONDITIONS	DAI-01			UNITS
		MIN	TYP	MAX	
Resolution		10	—	10	Bits
Analog Output Current	All Bits Low, V- Connected to FS Adjust	1840	—	2274	$\mu\text{A}$
Zero-Scale Output Current	All Bits High, V- Connected to FS Adjust	—	—	±0.011	% $I_{FS}$
Logic Input "0"	Measured with Respect to Output	—	—	0.7	V
Logic Input "1"	Measured with Respect to Output	2.1	—	—	V
Supply Current	All Bits High, V- Connected to FS Adjust	—	—	8.33	mA
Power Supply Rejection	$V_S = \pm 6\text{V}$ to $\pm 18\text{V}$	—	—	0.1	% $I_{FS}/\text{V}$

### NOTE:

Electrical tests are performed at wafer probe to the limits shown. Due to variations in assembly methods and normal yield loss, yield after packaging is not guaranteed for standard product dice. Consult factory to negotiate specifications based on dice lot qualification through sample lot assembly and testing.

## TYPICAL ELECTRICAL CHARACTERISTICS at $V_S = \pm 15\text{V}$ , and when connected to an ideal DAR-01, unless otherwise noted.

PARAMETER	CONDITIONS	DAI-01-N			DAI-01-G			UNITS
		MIN	TYP	MAX	MIN	TYP	MAX	
Full-Scale Temperature Coefficient (Note)		—	±60	—	—	±60	—	ppm/°C

### NOTE:

Full-Scale Temperature Coefficient is defined as the change in output voltage measured in the basic unipolar voltage output test circuit shown on the DAC-100 data sheet and is expressed in ppm between  $25^\circ\text{C}$  and either temperature extreme divided by the corresponding temperature change.

**BASIC CONNECTIONS**

**BASIC UNIPOLAR VOLTAGE OUTPUT CIRCUIT**

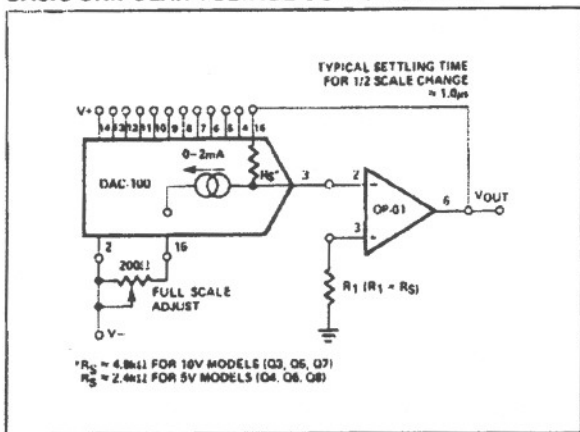

**BASIC BIPOLAR VOLTAGE OUTPUT CIRCUIT**

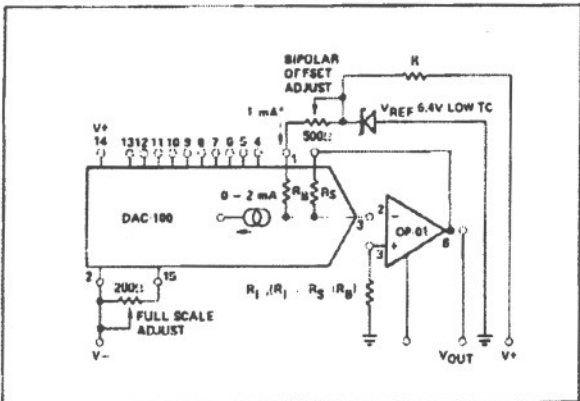

**APPLICATIONS INFORMATION**

**FULL RANGE OUTPUT ADJUSTMENT** — The output current of the DAC-100 may be reduced to produce an exact 10.000 (5.000) volt output by connecting a 200Ω adjustable resistance between the full-scale adjust pin and  $V^-$ . Adjustment should be made with an input of all "zeroes."

**LOWER RESOLUTION APPLICATIONS** — The DAC-100 may be used in applications requiring less than 10 bits of resolution. All unused logic inputs must be tied to logic high for proper operation. "Floating" logic inputs can cause improper operation.

**REDUCED RESOLUTION APPLICATION**

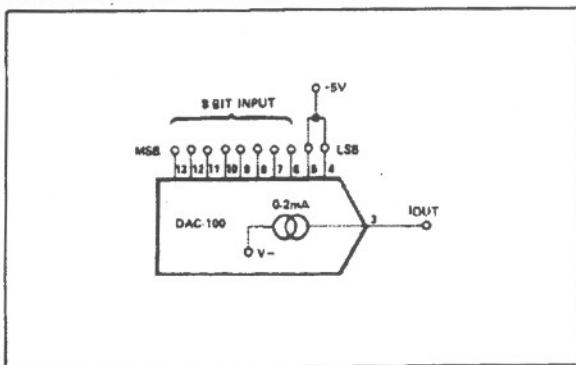

**LOGIC CODING** — The DAC-100 uses complementary or inverted binary logic coding, i.e., an all "zeroes" input produces a full range output, while an all "ones" input produces a zero-scale output. Each lesser significant bit's weight is one-half the previous more significant bit's value. High logic input turns the bit "OFF," low logic input level turns the bit "ON".

**LOGIC COMPATIBILITY** — The input logic levels are directly compatible with TTL logic and may also be used with CMOS logic powered from a single +5 volt supply.

**NONLINEARITY (NL)** — The maximum deviation from an ideal straight line drawn between the end points, expressed as a percent of full-scale range (FSR) or given in terms of LSB value. The end points are zero-scale output to full-scale output for unipolar operation and minus full-scale to positive full-scale for bipolar operation.

**BIPOLAR OPERATION** — The DAC-100 may be converted to bipolar operation by injecting a half-scale current into the output; this is accomplished by connecting the internal bipolar resistor to a +6.4 volt reference. Trimming of the zero output may be facilitated by placing a 500Ω adjustable resistance in series with the +6.4 volts.

**VOLTAGE AT OUTPUT PIN** — The DAC-100 is designed to be operated with the voltage at the output pin held very close to zero volts. Input logic threshold levels are directly affected by output pin voltage changes; voltage swings at the output may cause loss of linearity due to improper switching of bits. Large voltage swings may cause permanent damage and should be avoided. Proper operation can be obtained with output voltages held within  $\pm 0.7$  volts; a pair of back-to-back silicon diodes tied from the output to ground is a convenient way of clamping the output to this limit.

# DAC-100

## TYPICAL APPLICATIONS

### EXTERNAL REFERENCE CONNECTION

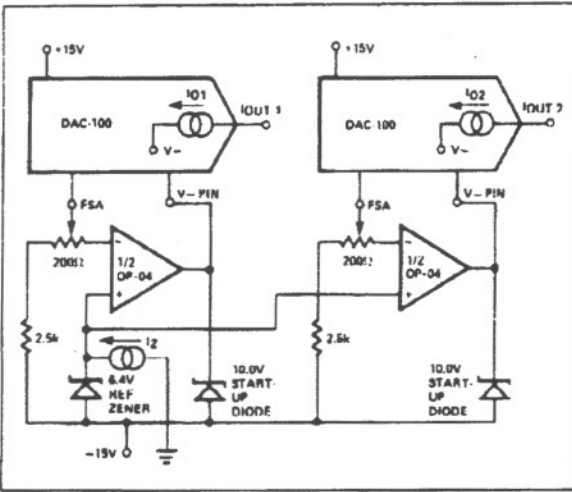

### ANALOG SUM OF TWO DIGITAL NUMBERS

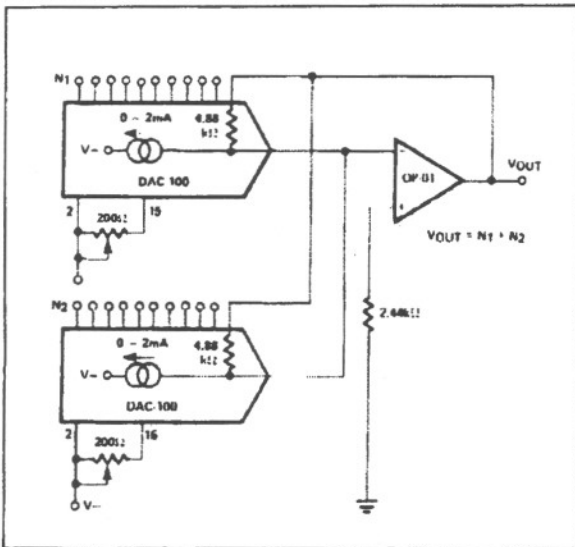

### DIGITALLY PROGRAMMED LEVEL DETECTOR

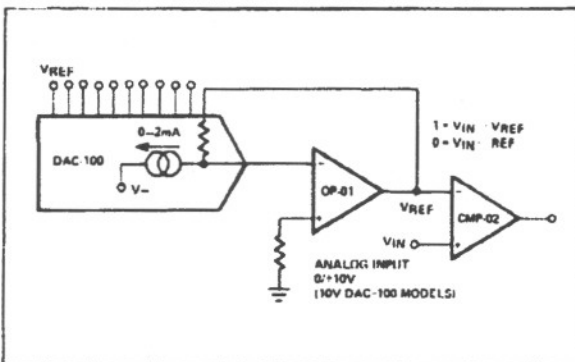

## BINARY-CODED-DECIMAL D/A CONVERSION

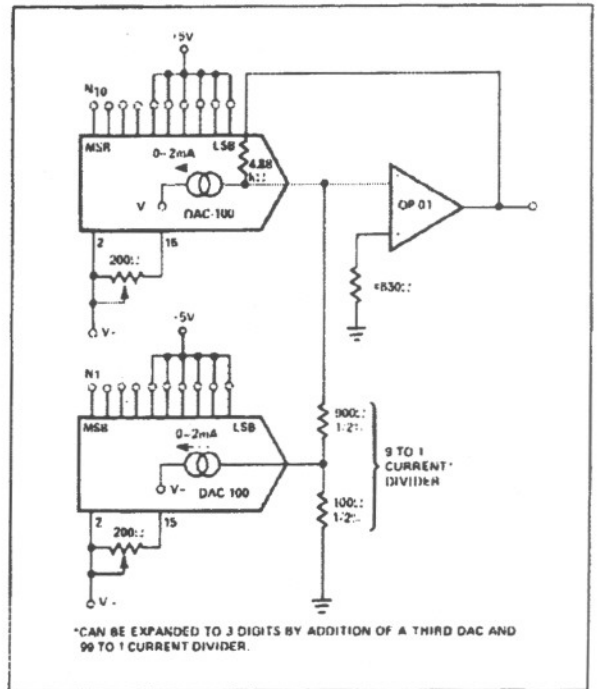

## INTERFACING WITH CMOS LOGIC

The DAC-100 requires only about  $1\mu\text{A}$  of input current into each logic stage. This enables use with CMOS inputs as long as one rule is observed; logic input voltages should not exceed 6.5 volts or  $V+$ , whichever is smaller. To provide an understanding of this rule, it is necessary to discuss the logic input stage design.

## LOGIC INPUT STAGE DESIGN

For simplicity, only one of the ten identical input circuits is shown below. The DAC-100 uses a fast current-steering technique that switches a bit-weighted current between the positive supply ( $V+$ ) and the analog output, which is usually constrained to be at zero volts (virtual ground) by an external summing amplifier.

## DAC-100 — LOGIC INPUT STAGE

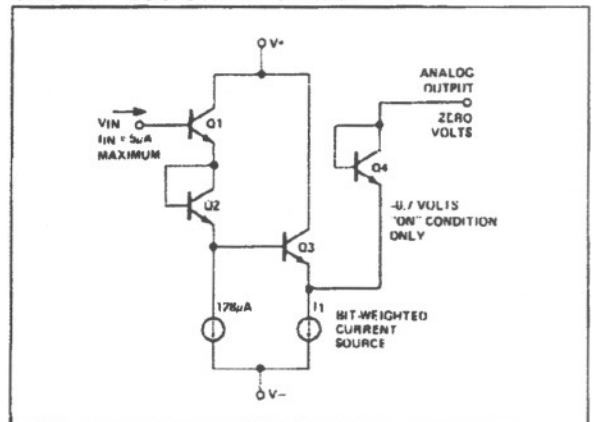

Switching is accomplished by forward biasing Q4, diode-connected transistor, for the bit "ON" condition and back biasing Q4 in the "OFF" condition. For the "ON" condition ( $V_{IN} \leq 0.7$  volts), Q3 is "OFF" — all of the bit-weighted current,  $I_1$ , flows from the analog output through Q4 and ultimately to V-. In the "OFF" condition ( $V_{IN} \geq 2.1$  volts), Q3 is "ON", Q4 is back biased, and the bit-weighted current is sourced from the positive power supply instead of the analog output.

If  $V_{IN}$  is too high, Q4's emitter-base junction will experience reverse breakdown and a fault condition will occur. Equation 1 describes this condition:

$$1) BV_{IH} = V_{BE1} + V_{BE2} + V_{BE3} + BV_{EB4} \approx 7.7 \text{ volts}$$

Using this relationship, it can be seen that a conservative input voltage limit would be around 6.5 volts. When the 6.5V input limit is observed, DAC-100 operation with CMOS inputs is easily achieved.

### ±5 VOLT POWER SUPPLY OPERATION

This is the most convenient method of interfacing the DAC-100 with CMOS logic. At ±6 volts the DAC-100 power dissipation is only 80mW, which is very small considering the inclusion of a complete internal reference. No interfacing components are required with ±5% power supplies, and the CMOS logic and DAC-100 can use the same ±6 volt power supply. In this application the device is directly CMOS compatible.

### BLOCK DIAGRAM — CMOS TO DAC-100 INTERFACE

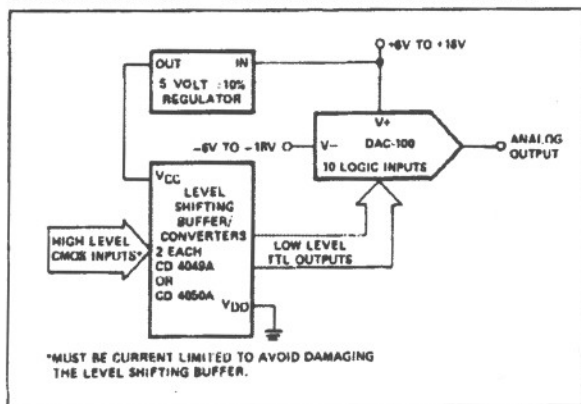

### HIGH LEVEL CMOS INTERFACING

The block diagram below illustrates a convenient method for interfacing CMOS input levels between 6.5 volts and 15 volts with the DAC-100. Inexpensive and readily available CMOS hex buffer/converters step down the high-level inputs to TTL levels that cannot exceed 5 volts — clearly satisfying the input stage voltage rule.

In addition to level shifting, buffer/converters provide input coding flexibility since they are available as inverting (CD4049A) or non-inverting (CD4050A) devices. This gives the user a choice between negative-true and positive-true binary coding and allows the same basic DAC-100 to CMOS interfacing method to be used in either type of application.

Since buffer/converter power consumption is very low, the required +5 volts can be provided by a simple regulator or even a resistive divider in some applications. In a multi-DAC system, one central, inexpensive three-terminal IC regulator can supply several level shifting devices.

### NOTE:

For a more complete explanation and detailed circuit connections, refer to AN-14, "Interfacing PMI D/A's with CMOS Logic."

### BURN-IN CIRCUIT

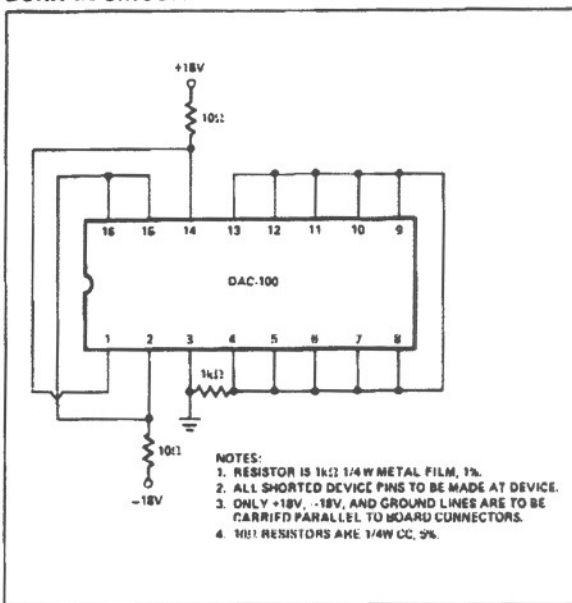



# DAC-100

## SUCCESSIVE APPROXIMATION A/D CONVERTER (8-BIT)

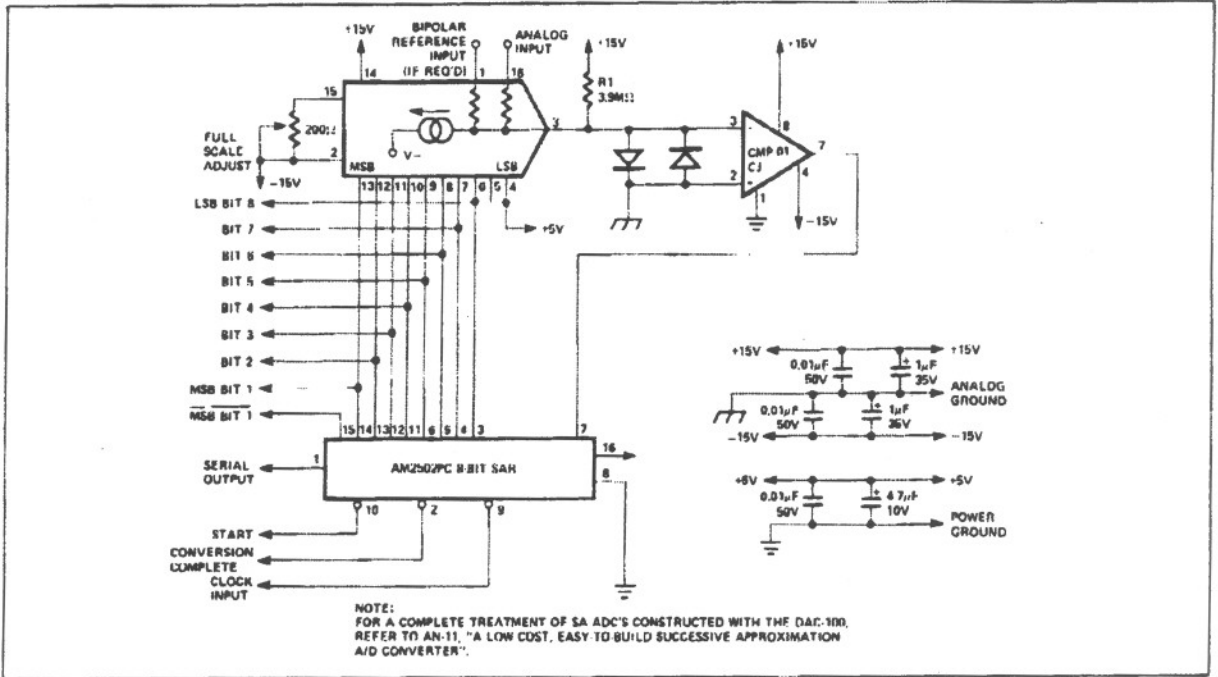

## TRACKING (SERVO-TYPE) A/D CONVERTER

