

Reprinted from MICROWAVES & RF December 1997

**DESIGN FEATURE**

*Switching Matrices*

# Design Techniques Enhance Isolation In Switch Assemblies

*By paying attention to PCB layout concerns, high isolation is achieved with low-cost, off-the-shelf MMIC components.*

**Robert Silverstein**

Hittite Microwave Corp., 21 Cabot Rd., Woburn, MA 01801; (781) 933-7267, FAX: (781) 932-8903.

**C**HANNEL switching represents a key function in cellular and personal-communications-services (PCS) base-station applications. This switching may be implemented in various sections of a system—for instance, between the transmit and receive paths, between multiple local-oscillator (LO) sources, or between antennas. A certain amount of isolation is required between paths, with this isolation requirement often being up to 60 dB (in some cases, more than 100 dB). In addition, commercial applications require small, low-cost solutions. Consequently, it is desirable to implement switching matrices using standard, off-the-shelf monolithic-microwave-integrated-circuit (MMIC) components in plastic packages. Guidelines for designing high-isolation RF switching matrices with standard components—including printed-circuit-board (PCB) layout techniques for minimizing secondary effects such as coupling, radiation, and leakage—are examined using two switch assemblies developed by Hittite Microwave Corp. (Woburn, MA).

Both designs (Fig. 1) use low-cost multilayer FR4 substrates. The first is a four-channel antenna selection matrix which provides 65-dB channel rejection across an operating frequency range of 100 MHz to 2 GHz. This circuit (Fig. 2) employs four positive-control HMC190M58 single-pole, double-throw (SPDT) switches and a single negative-control HMC182S14 single-pole, four-throw (SP4T) switch with an on-chip 24 decoder. A 2-bit

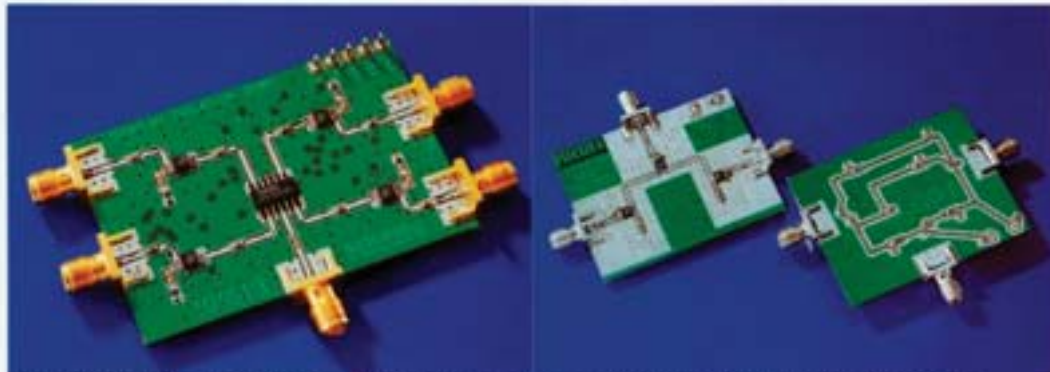

1. This four-channel antenna selection matrix (left) and two-channel LO selection circuit (right) operate across a frequency range of 100 MHz to 2 GHz.

17

FEATURED ARTICLES

## DESIGN TECHNIQUES ENHANCE ISOLATION IN SWITCH ASSEMBLIES

### DESIGN FEATURE

#### Switching Matrices

**Table 1: Isolation versus switch spacing**

Layout	Short	Medium	Long
Transmission-line length between switches	0.7 in.	0.8 in.	0.9 in.
Mean isolation (no shielding; 1 to 2 GHz)	75.6 dB	77.6 dB	79.7 dB
Change in isolation with increasing line length	0.0 dB	+2.0 dB	+4.1 dB

complementary-metal-oxide-semiconductor (CMOS)-compatible level-shifter/decoder circuit (using Zener diodes) is also incorporated, with CMOS logic gates to drive the five MMIC switches. Positive and negative supply voltages ( $\pm 5$  VDC) are required.

The second design is a high-isolation (> 90 dB) two-channel LO selection circuit which also operates from 100 MHz to 2 GHz. This circuit uses three positive-control HMC194MS8 SPDT switches and requires only two control lines (Fig. 3). Each of the HMC194MS8 switches is capable of delivering 40-to-50-dB isolation up to 2 GHz. By using proper layout techniques, isolation levels from 90 to more than 100 dB are achieved in a SPDT assembly formed with only three switches.

#### LRM CALIBRATION

In order to design an RF system using multiple packaged MMIC components, accurate S-parameter data must be obtained for the individual components. This is best accomplished by designing a custom evaluation printed-circuit board (PCB) and a set of LRM (line, reflect, match) calibration standards for each of the components. These standards typically consist of a zero-length through, an open or short, and a 50- $\Omega$  load on the same layout as the evaluation PCB traces.

LRM calibration standards have been devel-

oped for several products at Hittite Microwave, including the HMC182S14, HMC190MS8, and HMC194MS8 switches. These standards support de-embedding directly to the leads of the plastic MMIC packages. This approach is considerably more accurate than other common de-embedding methods since it accounts for actual PCB mismatches, line losses, and blocking-capacitor losses. However, there may be small errors associated with slight differences between the calibration and evaluation PCBs due to processing tolerances.

Using LRM calibration, two-port

S-parameter data was obtained for each operating state of every product. For instance, an SPDT switch such as the HMC194MS8 possesses four two-port data sets corresponding to the "ON" and "OFF" states along both switch paths.

#### RF CIRCUIT MODEL

A simple model for the desired system or subsystem can be constructed with the Libra simulation package from the Hewlett-Packard HP-EEsof Division (Westlake Village, CA) by using the two-port de-embedded S-parameters for the packaged MMICs. This model takes into account only the direct RF paths—neglecting the radiation, coupling, and leakage which may occur (these secondary effects will be addressed later). The model may be as simple as a few 50- $\Omega$  lines attached to the input and output of a single two-port data block or as extensive as the cascading of multiple two-port data blocks for different packaged MMICs as well as transmission lines, blocking capaci-

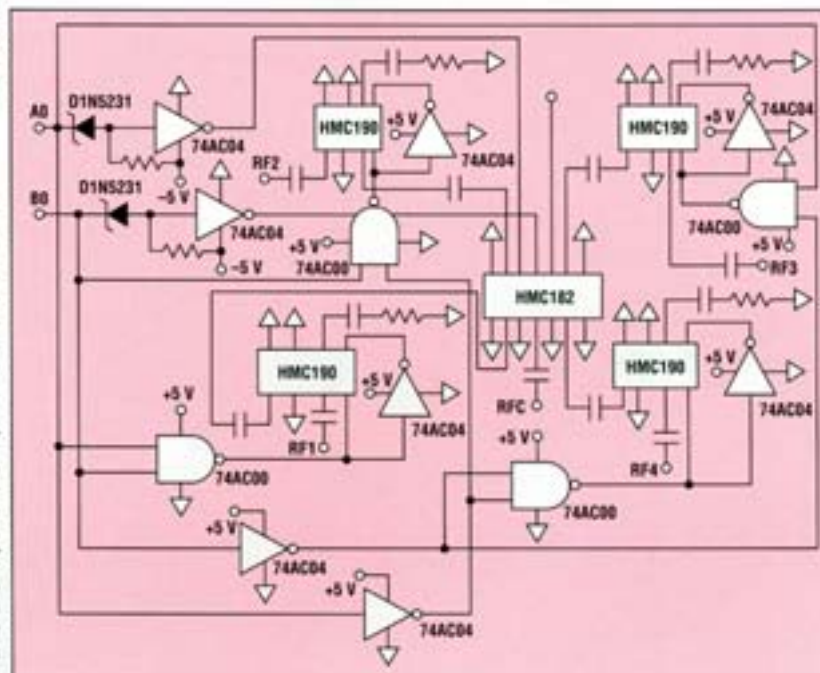

**2. The four-channel antenna selection matrix uses five MMIC switches that are controlled using integrated CMOS driver-logic circuitry.**

## DESIGN TECHNIQUES ENHANCE ISOLATION IN SWITCH ASSEMBLIES

### DESIGN FEATURE

#### Switching Matrices

**Table 2: Four-channel antenna switching matrix performance**

	800 to 1000 MHz	1800 to 2000 MHz
Return loss	18 dB	14 dB
Isolation	65 dB	65 dB
Insertion loss	1.4 dB	1.8 dB

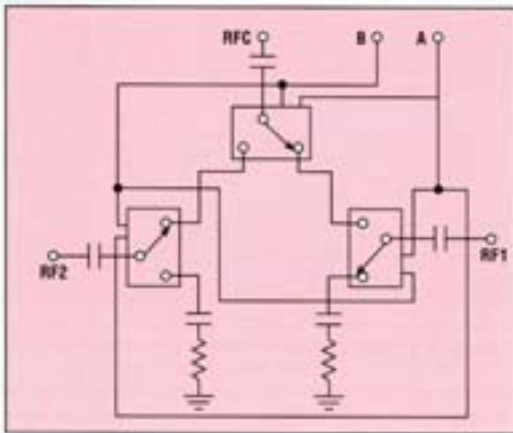

**3. This two-channel LO selection circuit provides better than 90-dB isolation while requiring only two control lines.**

tors, and other RF components. For a switching matrix, there will be Libra models for the ON (through) and OFF (isolated) states along each path of the matrix. For single-pole, N-throw (SPNT) switch matrices, there will be multiple OFF state models corresponding to the isolation between two channels when each of the other channels is selected. Designers may wish to use only the data

50- $\Omega$  line width ( $W$ ) = 0.038 in. (0.965 mm)

Coplanar gap ( $G$ ) = 0.013 in. (0.330 mm)

Loss tangent ( $\tan \Delta$ ) = 0.023 (0.584 mm)

DC-blocking capacitance = 330 pF

Figure 4 shows the Libra schematics for the four-channel antenna selection matrix. Figure 4a models the RF-common (RFC)-to-RF2 ON

for the worst-case path, as this greatly reduces the amount of required data.

For these switch-matrix designs, the Libra simulation incorporated grounded coplanar-waveguide transmission-line models (denoted as CPWG in Libra) in order to achieve the best possible isolation for the final physical layout. The following parameters were assumed (modeling low-cost FR4 material):

Relative dielectric constant ( $\epsilon_r$ ) = 4.6

Ground-plane spacing ( $H$ ) = 0.030 in. (0.762 mm)

state. Note that the HMC190MS8 and HMC182S14 switches are replaced by the two-port S-parameter data blocks corresponding to the appropriate states for each switch. This model is valid for all four S-parameters of the ON state. However, when constructing models for the isolation paths, the S-parameters of the overall circuit cannot be obtained from a single schematic model. For example, referring to Fig. 2, the match at antenna 2 when it is OFF (isolated) is found by modeling a single HMC190MS8 switch whose RF1 path is selected and terminated by a 50- $\Omega$  chip resistor. Figure 4b shows the schematic for this state.

Figure 5 presents the S-parameter response for the four-channel antenna matrix as modeled in Libra, with measured data included for comparison. The worst-case isolation is shown (corresponding to adjacent ports 2 and 3). The isolation between diagonal ports 2 and 4 is approximately 5 dB better, with the difference being associated with the packaging pin-out of the HMC182S14 device.

Figure 6 shows the Libra schematic for the two-channel LO selector design. This schematic corresponds to the RFC-to-RF1 ON state. The model uses quarter-wavelength ( $\lambda/4$ ) spacing at 2 GHz ( $\approx 0.7$  in.) between switches to enhance isolation. Figure 7 presents the measured and modeled S-parameters.

### LAYOUT GUIDELINES

There are a number of factors that are not taken into account in the sim-

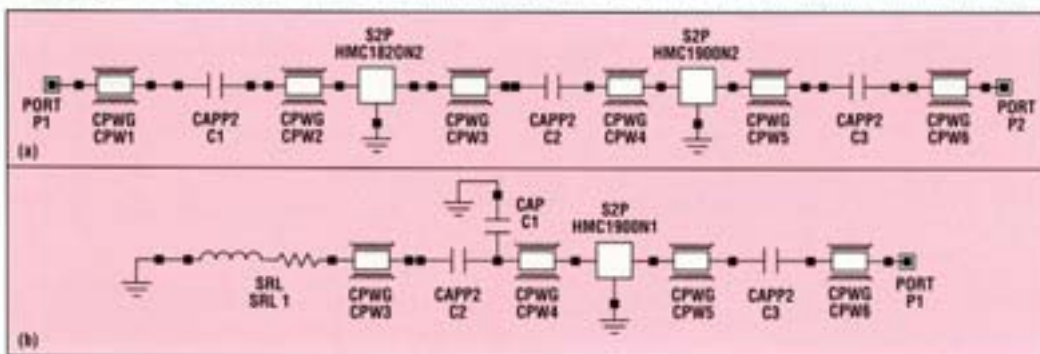

**4. These Libra models were obtained for the four-channel antenna matrix for the RFC-to-RF2 ON (a) and OFF states (b).**

## DESIGN TECHNIQUES ENHANCE ISOLATION IN SWITCH ASSEMBLIES

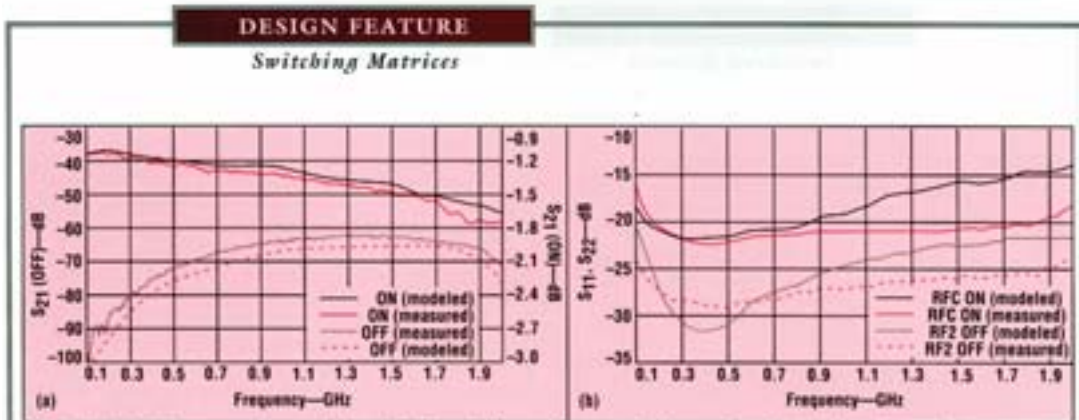

5. Simulated and measured transmission (a) and matching performance (b) are shown for the four-channel antenna selection matrix.

ple model. These factors include radiative coupling, transmission-line coupling, and RF-to-control line leakage. In some cases, neglecting these effects may only cost a few tenths of a decibel. In other cases, the results may be devastating—on the order of 30 dB or more in terms of performance degradation. In a design where low isolation is expected (40 dB or lower), effects such as radiation and RF leakage may be masked by the inherent isolation limitations of the selected devices. However, in cases where the MMIC isolation “noise floor” is lower than 50 or 60 dB, layout-related issues become significant. Following appro-

appropriate RF-layout guidelines can minimize or eliminate these secondary effects.

Traditional RF-layout guidelines include the use of mitered bends, adequate spacing between RF transmission lines, tapered transitions, maintaining proper 50-Ω line widths, as well as proper grounding of components and connectors. However, high-isolation switching matrices require tighter layout constraints in order to achieve the performance shown in models.

Both of the circuit designs presented here use grounded-coplanar-waveguide (CPW) transmission lines, as

opposed to microstrip. There are several reasons why CPW is a desirable layout choice:

- CPW transmission lines with tight gaps support narrower lines, thereby easing layout constraints.
- CPW should reduce radiation and coupling since fringing fields above the PCB will have a top-layer ground on which to terminate.
- CPW provides a ground under all board components. By using a higher density of plated-through ground vias under components, isolation can be improved.
- CPW lines are convenient for RF bypassing of DC and low-frequency

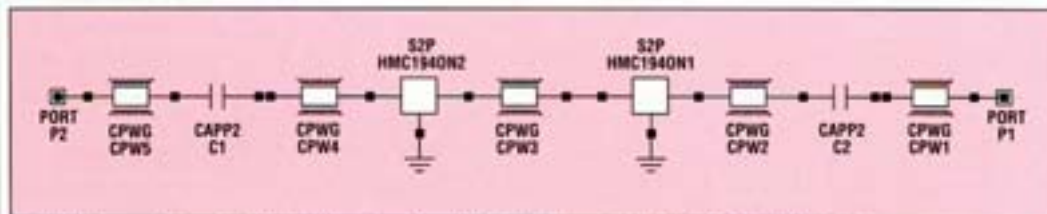

6. This Libra model was obtained for the two-channel LO selection matrix in the RFC-to-RF1 ON state.

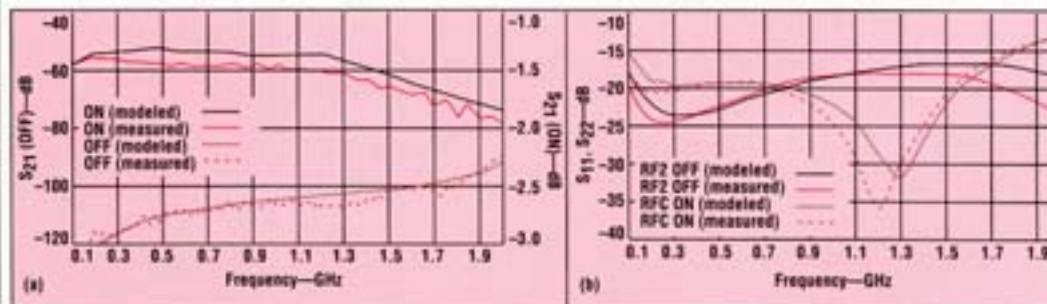

7. Measured as well as simulated transmission (a) and matching parameters (b) were obtained for the two-channel LO selection matrix.

## DESIGN TECHNIQUES ENHANCE ISOLATION IN SWITCH ASSEMBLIES

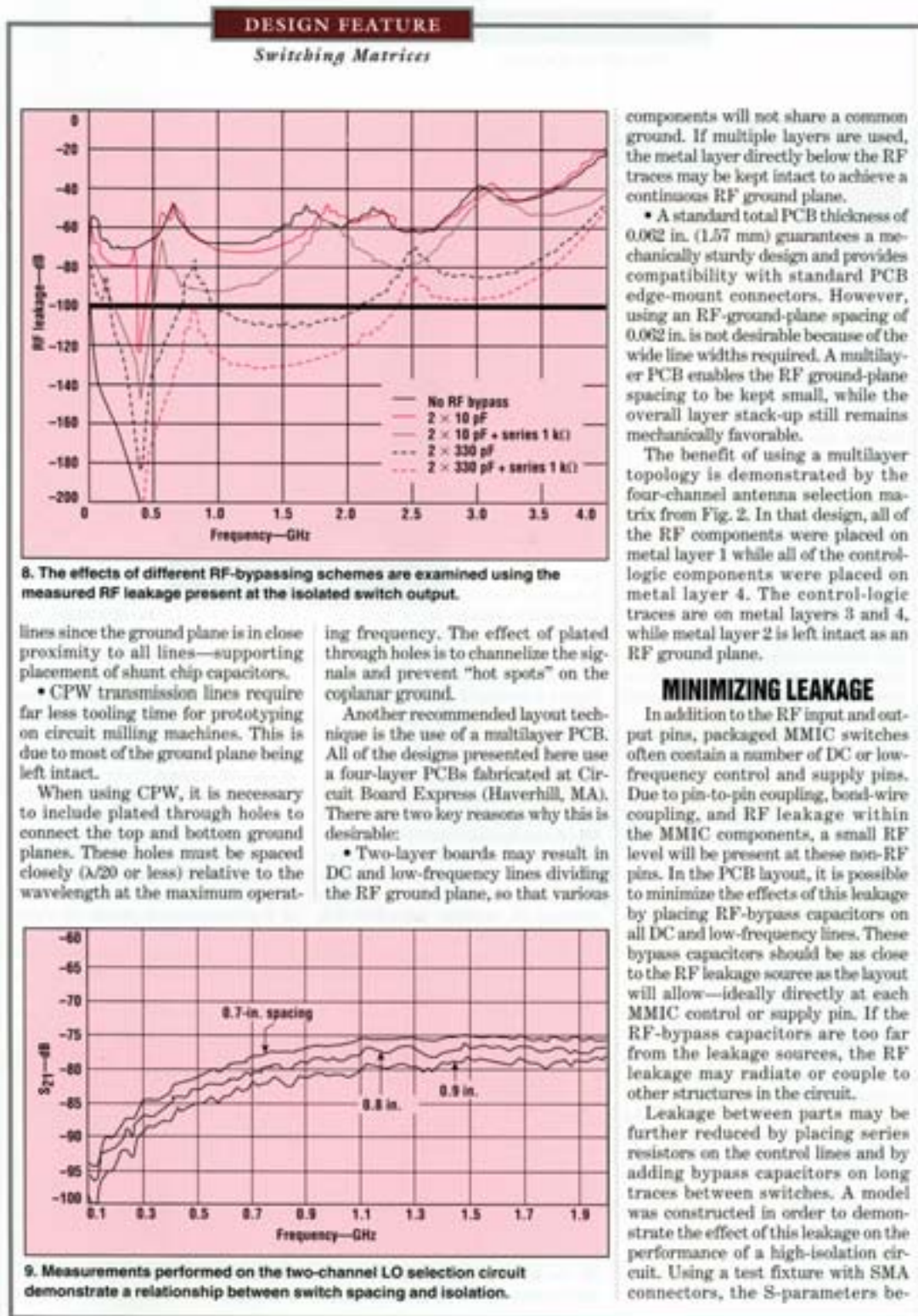

## DESIGN TECHNIQUES ENHANCE ISOLATION IN SWITCH ASSEMBLIES

### DESIGN FEATURE

#### Switching Matrices

**Table 3: Two-channel LO selection circuit performance**

	800 to 1000 MHz	1800 to 2000 MHz
Return loss	17 dB	14 dB
Isolation	105 dB	92 dB
Insertion loss	1.5 dB	2.0 dB

tween the RFC and the A and B control lines of the HMC194MS8 SPDT switch were measured. This measurement was performed by using a bias tee to inject DC onto the control line. The insertion loss due to RF leakage was approximately 25 to 30 dB at 2 GHz.

Next, the measured RF-to-control S-parameter data was used to obtain a Libra model for a single length of control line between two switches on the two-channel LO selection circuit. Figure 8 shows the RF level present at the isolated switch output due to the leakage on this single control line for four different bypassing schemes. For high-isolation cellular or PCS applications, RF bypassing of 330 pF with a series 1-k $\Omega$  resistor on each control line is recommended.

There is, however, a trade-off between switching speed and isolation—governed by  $\tau = RC$  (where  $\tau$  is the switching time constant, R is resistance, and C is capacitance). The largest possible bypass capacitors which still meet the switching-speed requirements should be selected in order to maintain a low-impedance path to ground. This is particularly important in the lower frequency range since the impedance (Z) of a capacitor is governed by  $Z = 1/j\omega C$  (where  $\omega$  is the radian frequency).

Radiative coupling is a critical factor in applications requiring extremely-high isolation. When a transmission line terminates at the pin of a packaged component, most of the signal is either launched into the device or reflected. However, the non-ideal nature of the transition will result in a small fraction of the power being radiated. In effect, the transition behaves like an antenna (fortunately, an extremely inefficient one). The intensity of the radiation decreases rapidly with distance. However, some of the radiation may

couple back into the circuit. This can occur in undesirable locations, such as the isolated path of a switch matrix.

A demonstration of the effects of radiative coupling was performed. Three versions of the two-channel LO selection circuit were built—with the transmission-line spacing between switches at 0.7, 0.8, and 0.9 in. (1.78, 2.03, and 2.29 cm), respectively. Figure 9 compares the measured isolation for each design while Table 1 presents the mean isolation in the boards.

There is a direct relationship between switch spacing and isolation. Note that in all three cases shown in Fig. 9, the isolation performance falls far short of the modeled data from Fig. 7a. This discrepancy is primarily due to channel-to-channel radiative coupling. To minimize this effect, it is necessary to use RF shielding covers. By enclosing each switch in a small housing, the radiation between channels is almost totally eliminated, im-

proving isolation performance by more than 25 dB (Fig. 10). The RF shields used are standard off-the-shelf products from Fotofabrication Corp. (Chicago, IL).

The results in Table 1 suggest positioning the switches as far apart

as possible in order to improve isolation. However, this is impractical due to a resonance that moves down infrequency as the spacing between switches is increased. Figure 11 shows modeled data for the isolation performance as a function of switch spacing. When the transmission-line length reaches 1.5 in. (3.81 cm), the

resonance is in the PCS frequency band. Consequently, there is a trade-off between reducing the radiative coupling (unshielded) and avoiding this resonance. A reasonable compromise is to allow a  $\lambda/4$  spacing between switches at the highest frequency of interest.

Most of the design and modeling focus has been on describing the isolated states of the switching matrices. However, there are some considerations that must be taken into account in order to develop an accurate model of the transmission states. The primary requirements are:

- Accurate line-length measurements (when back-modeling existing physical designs).

**USING A MULTILAYER BOARD PROVIDES SEVERAL ADVANTAGES, INCLUDING THE ABILITY TO MAINTAIN A CONTINUOUS RF GROUND PLANE AND SMALL GROUND-PLANE SPACING.**

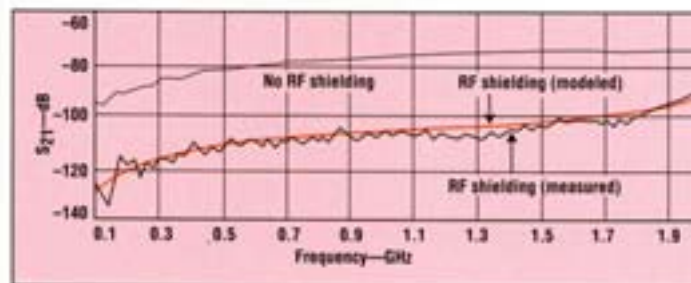

10. The isolation performance of the two-channel LO selection circuit is significantly improved by employing RF shielding.

## DESIGN TECHNIQUES ENHANCE ISOLATION IN SWITCH ASSEMBLIES

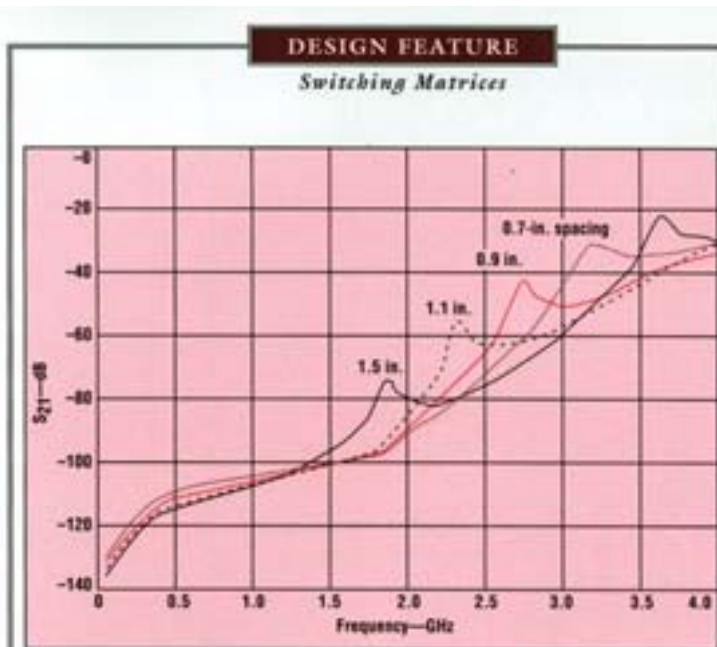

11. The LO selection circuit's simulated isolation demonstrates a resonance that moves down in frequency as the switch spacing increases.

- Accurate estimation of  $\epsilon_r$  and  $\tan \delta$ .
- Valid models for DC-blocking capacitors (including quality factor (Q) and resonance frequency).

The first criteria is easy to accomplish. However, it is important because an error of a few tenths of an inch in line-length estimation can result in a few hundred megahertz of offset for certain performance attributes, such as nulls in the return loss or isolation.

Material parameters such as  $\epsilon_r$  and  $\tan \delta$  are generally not specified precisely for low-cost materials such as FR4. However, these parameters can be determined experimentally. Note that  $\epsilon_r$  affects not only the transmission-line impedance, but also the electrical length. For the FR4 material used, the measured PCB loss for 50- $\Omega$  lines was approximately 0.1 dB/(in.-GHz)—corresponding to a  $\tan \delta$  of approximately 0.023.

An accurate circuit model for the capacitors should be obtained from the manufacturer. This is critical since at high frequencies (> 2 GHz), typical low-cost capacitors exhibit a roll-off in their insertion-loss performance (due to their resonance characteristics). The modeled data given here uses the Libra CAPP2 model for non-ideal capacitors.

It may be undesirable to use DC-blocking capacitors in high-frequency designs due to the insertion-loss roll-off induced by these devices. In the two-channel LO selection circuit, it may be possible to eliminate DC-blocking capacitors if the system in which the circuit is used is AC-coupled. However, in the four-channel antenna selection matrix, the inter-switch DC blocking is required since the four HMC190MS8 chips and the HMC182S14 switch are operated at different logic levels. An optional design involves operating the HMC190MS8 with negative logic levels, eliminating the need for the five inter-switch DC-blocking capacitors.

Tables 2 and 3 summarize the measured performance of the SP4T antenna switching matrix and the SPDT LO-selection circuit, respectively. With two design iterations, the measured performance of the devices achieved close agreement with the modeled data. ♦♦

#### Note

De-embedded S-parameters for various products, including the SPDT and SP4T switches described in this article, are available on the Internet at <http://www.hittite.com>.

Copyright©1997 by Penton Publishing, Inc., Cleveland, Ohio 44114

\*Reprinted with the permission of Microwaves & RF.

For price, delivery, and to place orders, please contact Hittite Microwave Corporation:  
20 Alpha Road Chelmsford, MA 01824 Phone: 978-250-3343 Fax: 978-250-3373  
Order Online at [www.hittite.com](http://www.hittite.com)