

# DESIGN NOTES

## High Performance Frequency Compensation Gives DC-to-DC Converter 75 $\mu$ s Response with High Stability – Design Note 53

Ron Vinsant

This Design Note describes four high performance, low cost, 1.75A step-down converter circuits based on the LT<sup>®</sup>1076 five terminal switching regulator. All four circuits have exceptional transient response; indeed, it is superior to most three terminal linear regulators. Transient response is important to loads that are switched on and off or that require high peak currents. Examples are digital circuits that are turned on and off, disk drive motors, stepper motors and linear amplifiers. The frequency compensation schemes shown in this Design Note, when compared to the usual R and C technique, allow greater variation in output capacitor ESR without causing stability problems. This is important in applications where wide temperature variations occur (which changes capacitor ESR) such as industrial control, automotive and military, and when the use of multiple capacitor vendors with different capacitor specifications is required.

Phase margin is always more than 50° and gain margin is a minimum of 18dB. Bode plots are available from the factory upon request.

The efficiency of these circuits is typically 80% with output ripple less than 50mV. Input voltages can be as high as 45V. Input ripple rejection is an exceptional 60dB due to the feedforward architecture of the LT1076. These circuits use a small number of external parts that are available off-the-shelf.

Many of the problems associated with five terminal switching regulators have been addressed by these circuits. Start-up overshoot is less than 5% with the optional soft start circuit. On recovery from a short circuit, a 10% overshoot is realized.

For a 15V output, line regulation is typically 0.06% (10mV) for a 20V to 40V input voltage change. Load regulation is difficult to measure; in fact, it is only 1mV to 2mV at the point of regulation. This applies to all output voltages.

Each circuit has been built in our lab and evaluated for stability, temperature, component life and tolerance. Two circuit options are shown: a simple soft start circuit and an output voltage adjustment (see Figure 1).

### Inductors

The inductors shown in Table 3 are designed around two different core materials. The first is powdered iron based for low cost. The second is tape wound steel for smaller size and higher efficiency but greater cost. For rapid evaluation of these circuits, powdered iron cores are available in sample quantities from Micrometals at 1-800-356-5977. Completed inductors are available from Coiltronics at 305-781-8900.

### Capacitors

Ripple current in the output capacitor is 150mA maximum with the input voltage at 40V and maximum load. At 35°C ambient estimated life-time with the specified capacitor and full load is 28 years.

The input capacitor, which undergoes higher stress, has a ripple current of 830mA maximum at 14V input and maximum load. The life-time of this capacitor is 14 years at 35°C. If the ambient temperature is higher, the life of the capacitor will be cut in half for every 10°C increase. The ESR specification affects the output ripple as well as frequency compensation. Its value of capacitance is not critical.

The capacitors in the frequency compensation network should be at least X7R ceramic, never Z5U, and, if broad temperature operation is expected, polyester or polycarbonate film caps should be used.

Manufacturing technologies must also be taken into account. If an IR furnace is used for soldering, use only ceramic capacitors. A wave or hand soldering operation is suggested for both film and electrolytic capacitors. This is an area of continuing development

LT, LT, LTC, LTM, Linear Technology and the Linear logo are registered trademarks of Linear Technology Corporation. All other trademarks are the property of their respective owners.

so be sure to contact the capacitor manufacturers for temperature profiles.

### Layout

In order to achieve proper performance it is important to lay out the circuit as the schematic indicates. Use a single point ground at the output of the converter as shown. The term “short” indicates that the trace should be as short as possible between the two points shown. These traces should have a minimum width of 0.2 inches in 2oz. copper for a length of less than 1.5 inches. Traces longer than this should be avoided on the heavily shaded portions of the schematic.

### Output Adjustment

A potentiometer can be added to the output divider string, provided the string does not change its overall resistance value. A table showing resistance values is shown with the schematic.

### Heat Sinking

Any heatsink of 30°C/W (~2 square inches) or lower will keep the LT1076 at an acceptable temperature up to a 70°C ambient. See LT1076 data sheet for further information.

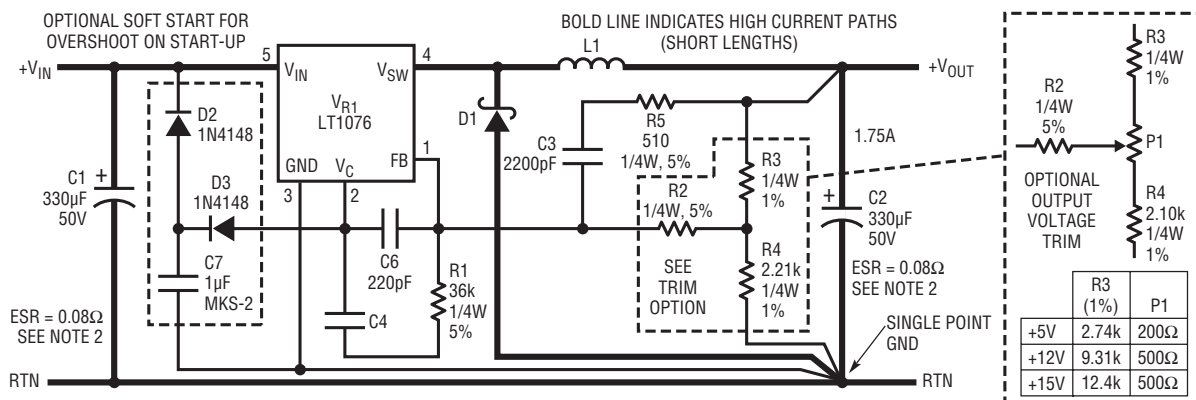

**NOTE 1:** DO NOT SUBSTITUTE COMPONENTS WITHOUT COMPLETE EVALUATION.  
**NOTE 2:** C1 AND C2 MUST BE 0.07Ω MIN ESR AT ROOM TEMPERATURE (25°C). UNITED CHEMICON SXE50VB331M10X30LL, SPRAGUE 672D337F020DM4D.

**NOTE 3:** ALL CAPS EXCEPT C1 AND C2 ARE WIMA FK2 OR X7R CERAMIC, ±10% TOLERANCE. WIMA 914-347-2474

DN53 • TA01

Figure 1. High Performance DC-to-DC Converter

Table 1. Components

#	V <sub>IN</sub>	V <sub>OUT</sub>	e (%) at V <sub>IN</sub>	L (µH)	D1	R2 (5%)	R3 (1%)	C4 (10%)
1	8V-20V	+5V	83% at 10	75	MBR330P	1.5k	2.80k	0.0068µF
2	8V-40V	+5V	76% at 24	91	MBR350	1.5k	2.80k	0.0068µF
3	15V-40V	+12V	86% at 24	180	MUR415	1.2k	9.79k	0.01µF
4	18V-40V	+15V	86% at 24	240	MUR415	1.2k	12.7k	0.01µF

Table 2. Performance

#	V <sub>OUT</sub>	MIN LOAD	REGULATION (MIN TO MAX)		RIPPLE REJECTION 50Hz-400Hz	OUTPUT RIPPLE
			LOAD	LINE		
1	+5V	0.200	0.1%	15mV	60dB	50mV
2	+5V	0.175	0.1%	15mV	60dB	50mV
3	+12V	0.175	0.1%	15mV	60dB	50mV
4	+15V	0.175	0.1%	15mV	60dB	50mV

**Note 1:** V<sub>IN</sub> = 24V except #1 at 14V.

**Note 2:** Temperature = 25°C.

**Note 3:** Periodic and random deviation (P.A.R.D.).  
 With optional adjustment = ±2.5%.  
 Without optional adjustment = ±4.5%.

Table 3. Inductor

L (µH)	NUMBER TURNS	CORE	COILTRONICS P/N	SMALLER TOROID
75	37 #18	T68-52A	CTX75-2-52	CTX75-2-KM
91	38 #18	T80-52B	CTX91-2-52	CTX91-2-KM
180	53 #18	T80-52B	CTX180-2-52	CTX180-2-KM
240	61 #18	T80-52B	CTX240-2-52	CTX240-2-KM

**Note 1:** ΔL with DC current is 20% max.

Data Sheet Download

www.linear.com

For applications help,  
 call (408) 432-1900