

High Efficiency Linear and Switching Solutions for Splitting a Digital Supply – Design Note 172

Dave Dwelley and Gary Maulding

It can be inconvenient to generate a split supply in a typical digital system. The classic solution is to use a pair of resistors between 5V and GND to create a 2.5V “ground” for analog circuitry (Figure 1). Unfortunately, the resultant “ground” has a painfully high impedance and the resistors draw a large amount of supply current. The output can be buffered with an op amp to lower the impedance, but a specialized op amp is required to handle any significant bypass capacitance at the output. This Design Note presents two alternate methods of creating a split supply that can provide good transient response while conserving supply current.

loading conditions, far better than any practical resistor divider solution. The LT1118 draws only enough supply current to meet the demands of the load at the split supply, providing nearly 50% power efficiency over a wide range of load currents (Figure 3). Load transient response is excellent, with less than 5 μ s recovery time from a \pm 400mA current load step (Figure 4). At low current levels, the LT1118 is the optimum solution for splitting a digital supply.

LT, LT, LTC, LTM, Linear Technology and the Linear logo are registered trademarks of Linear Technology Corporation. All other trademarks are the property of their respective owners.

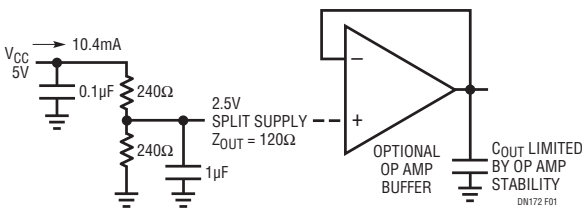

Figure 1. Resistor Divider Supply Splitter

The LT[®]1118 is a specialized linear regulator designed to source or sink current as necessary to keep its output in regulation. It can handle output capacitors of arbitrarily large size, improving output transient response. Available with a fixed 2.5V output (ideal for splitting 5V supplies), it draws only 600 μ A quiescent current typically and can source 800mA or sink 400mA, enough to satisfy most analog subsystems. The LT1118 requires only two external components (Figure 2) and features a DC output impedance below 0.1 Ω under all

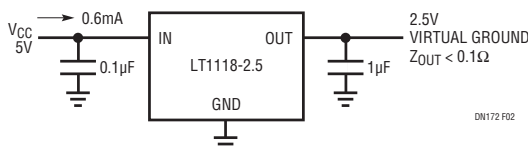

Figure 2. LT1118-2.5 Supply Splitter

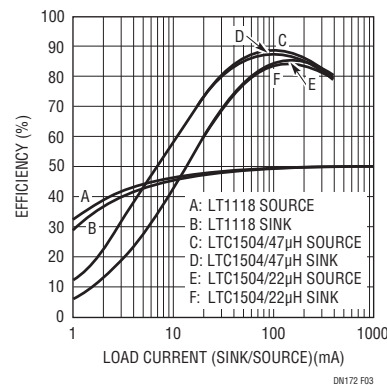

Figure 3. Efficiency vs Load Current for Linear and Switching Circuits

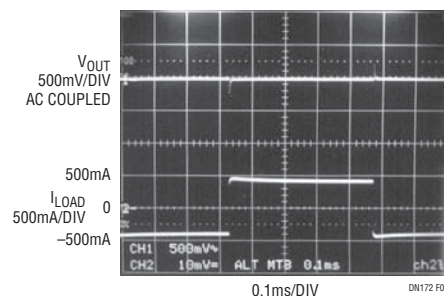

Figure 4. LT1118 Transient Response

At higher power levels, the 50% efficiency of the LT1118 can become a liability in power-sensitive or battery-powered systems since half of all the power drawn from the split supply is wasted heating up the LT1118. The LTC[®]1504 addresses this situation by providing as much as 90% efficiency while sourcing or sinking up to 500mA. The LTC1504 is a synchronous switching regulator with on-board power switches. The continuous conduction, synchronous buck architecture inherently sinks current as well as sourcing it, making the circuit an effective supply splitter. Quiescent current is 3mA with typical components. This penalizes efficiency at low current levels when compared to the LT1118, but the intrinsic power conversion abilities of the inductor-based switching architecture allow power efficiencies approaching 90% above 100mA (Figure 3 again). A typical LTC1504 circuit will draw only 56mA from the 5V supply while sourcing 100mA from the 2.5V output—magic!

The switching architecture of the LTC1504 requires a few more external components than the LT1118 (Figure 5), and generates a small amount of output noise at the 200kHz switching frequency. Transient recovery is controlled primarily by the value of the external inductor. With a 47μH inductor, switching noise is minimal

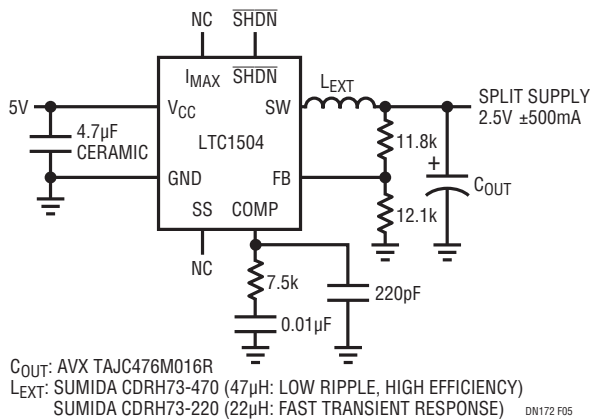

Figure 5. LTC1504 Supply Splitter

and the circuit recovers from a ±400mA output load step in 30μs (Figure 6). Switching to a 22μH inductor brings transient recovery time down to 15μs (Figure 7), but output ripple and quiescent current increase. The LTC1504 features a shutdown pin that drops quiescent current below 10μA when the split supply is not required.

Both the LT1118 and the LTC1504 provide superior supply splitting when compared to simple resistor- or regulator-based circuits. The LT1118 fits best where impedance requirements are critical at low current levels, or where low output noise is paramount. The LTC1504 is the best solution where efficiency, especially at high current levels, is the overriding concern. Both devices can also be used in similar applications where source/sink capability is important, such as SCSI or positive ECL supplies.

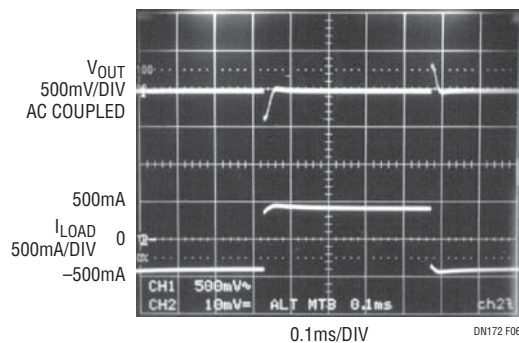

Figure 6. LTC1504 Transient Response with 47μH Inductor

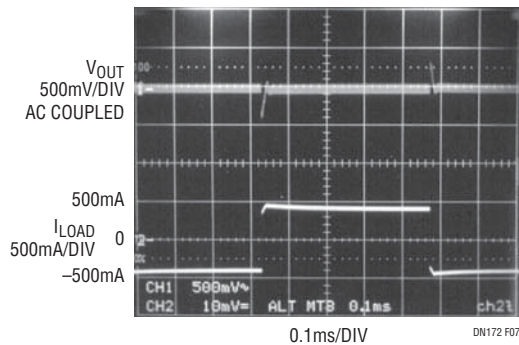

Figure 7. LTC1504 Transient Response with 22μH Inductor

Data Sheet Download

www.linear.com

For applications help,
call (408) 432-1900

Linear Technology Corporation
1630 McCarthy Blvd., Milpitas, CA 95035-7417
(408) 432-1900 • FAX: (408) 434-0507 • www.linear.com

dn172f_conv LT/TP 0198 340K • PRINTED IN THE USA

LINEAR TECHNOLOGY
© LINEAR TECHNOLOGY CORPORATION 1998