

Single 4-Input IC Gives Over 90dB Crosstalk Rejection at 10MHz and is Expandable – Design Note 79

John Wright

Introduction

Professional video systems need to multiplex between many signals without interference from adjacent video sources that are not selected. Final system crosstalk rejection of all non-selected or “Hostile” signals of 72dB is regarded as “professional quality.” This level of isolation is very difficult to achieve because every doubling in the number of inputs degrades the crosstalk by 6dB. In the past because no single IC was good enough, cascades of discrete switches and amplifiers were used to achieve the necessary isolation. An additional requirement of some video multiplexers is the ability to switch quickly and cleanly so the sources can be changed in picture without visible lines or distortion. New emerging multimedia systems require the performance of professional systems in the PC environment.

The new LT1204 four-input video multiplexer IC speeds the design of high performance video selection products. It features easy input expansion, and over 90dB crosstalk rejection on a PC board up to 10MHz even when expanded to 16 inputs. Additionally, this new multiplexer has low switching transients and includes a

75MHz current feedback amplifier to drive 75Ω cables. Figure 1 shows the LT1204 in a typical application.

Expanding the Number of Inputs

To expand the number of MUX inputs LT1204s can be paralleled by shorting their outputs together. The Disable feature ensures that amplifier outputs that are not selected do not alter the cable termination. When the LT1204 is disabled (pin 11 low), the output stage is turned off and the feedback resistors are bootstrapped, effectively removing them from the circuit. This has the effect of raising the “true” output impedance to about 25k in Figure 1. The LT1204 disable logic has been designed to prevent shoot-through current when two or more amplifiers have their outputs shorted together. The LT1204 also has a logic controlled shutdown (pin 12 low) that drops the supply current from 19mA to 1.5mA. When shut down, the feedback resistors load the output because the bootstrapping is inoperative. Figure 2 shows this loading effect for a 16-to-1 MUX made with four LT1204s using the Disable feature vs the Shutdown feature.

LT, LT, LTC, LTM, Linear Technology and the Linear logo are registered trademarks of Linear Technology Corporation. All other trademarks are the property of their respective owners.

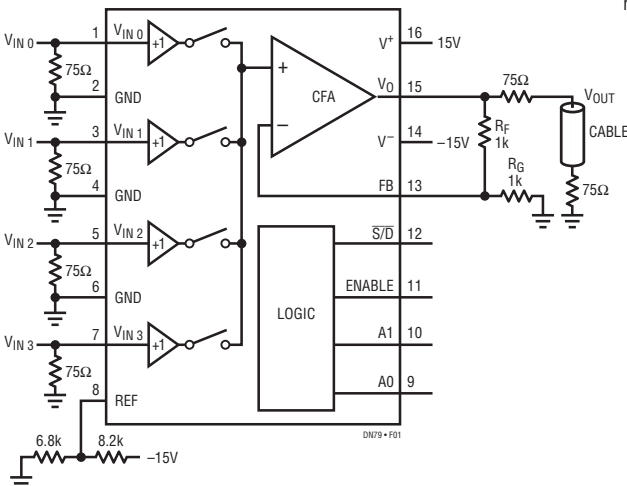

Figure 1. 4-Input Video Multiplexer with Cable Driver

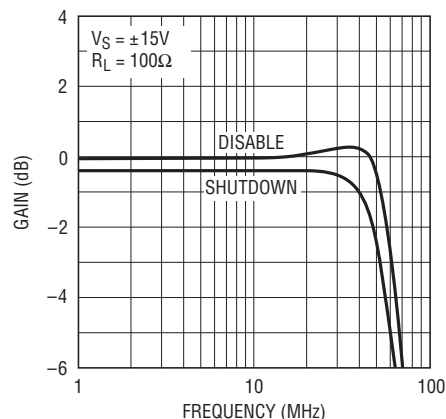
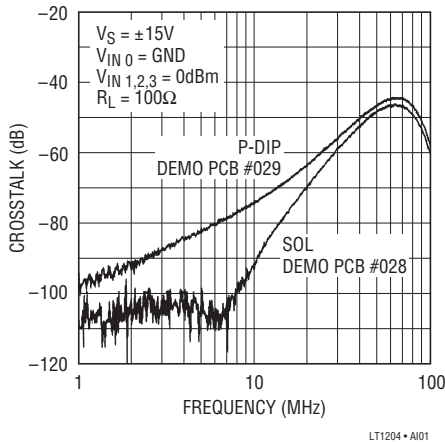

Figure 2. 16-to-1 Multiplexer Response Using Disable Feature vs Shutdown Feature

PC Board Layouts

Crosstalk is a strong function of the IC package, the PC board layout, as well as the IC design. Layout of a PC board that has over 90dB crosstalk rejection at 10MHz is not trivial. PC boards have been fabricated to show the component and ground placement required to attain this level of performance. It has been found empirically from these PC boards that capacitive coupling across the package of greater than 3fF (0.003pF) will diminish the rejection. Keys to the layout are: placing ground plane between inputs, minimizing the feedback pin trace length, putting feedback resistors on the back side of the surface mount PC board, and guarding pin 13 with ground plane.

Crosstalk in P-DIP and SOL vs Frequency



Switching Transients

Multimedia systems switch active video “in-picture” to create special effects and this requires fast clean transitions with low “glitch” energy. In the past video source selection was made during the blanking period and switching transients were not visible. The LT1204 has input buffers that isolate the internal make-before-break switches. These buffers ensure glitches are minimized at the inputs. This is important because loop-through connections send these glitches to other equipment. When two channels are on momentarily the more positive voltage passes through; if both are equal,

there is only a 40mV error at the input of the CFA. The time of this 40mV error can be reduced by adjusting the voltage on the Reference (pin 8). The Reference pin is used to trade off positive input voltage range for switching time. On $\pm 15V$ supplies, settling the voltage on pin 8 to $-6.8V$ reduces the switching transient to a 50ns duration, and the positive input range reduces from 6V to 2.35V. The negative input range remains unchanged at $-6V$. Included are photos of the switching transients for the new LT1204 as well as competitive CMOS and bipolar MUXs.

LT1204 Output Switching Transients

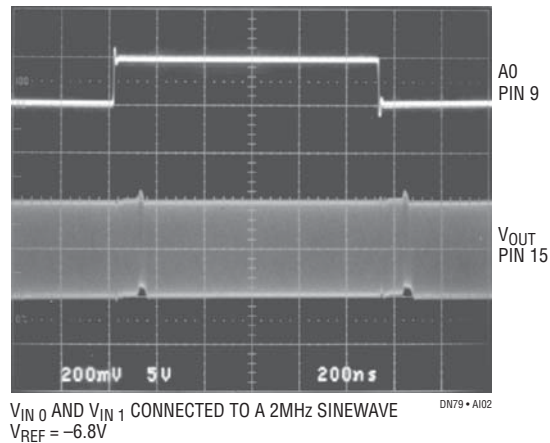

Competitive MUXs

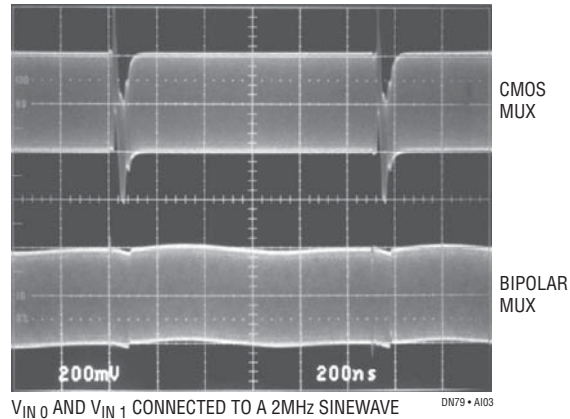

Data Sheet Download

www.linear.com/LT1204

For applications help,
call (408) 432-1900, Ext. 456

Linear Technology Corporation
1630 McCarthy Blvd., Milpitas, CA 95035-7417
(408) 432-1900 • FAX: (408) 434-0507 • www.linear.com

dn79f_conv LT/GP 0294 190K • PRINTED IN THE USA

© LINEAR TECHNOLOGY CORPORATION 1994