

DESIGN NOTES

60V Step-Down DC/DC Converter Maintains High Efficiency

Design Note 269

Mark W. Marosek

Introduction

Monolithic step-down converters capable of operation at high input voltages are usually optimized for efficiency at high input-to-output voltage differentials. At such low duty cycle operation where DC switch losses are less critical, the switch design is often neglected, resulting in a switch resistance that (for some 1.5A converters) can be as poor as 1Ω . Such converters sacrifice efficiency when lower input-to-output voltage differentials are required. The switch drop can also limit maximum duty cycle—putting a limit on the minimum input voltage for a given regulated output voltage.

The LT[®]1766 is designed to optimize efficiency for both high and low input-to-output voltage differentials to support a wide input voltage range. In addition, the current mode topology used to provide fast transient response and good loop stability does not suffer from peak switch current fall off at low input-to-output voltage differentials, commonplace in most current mode converters.

The LT1766 is a 1.5A monolithic buck switching regulator. The 5.5V to 60V input voltage range makes the LT1766 ideal for 48V nonisolated telecom applications

as well as 12V, 24V and (future) 42V automotive applications. These systems must survive load-dump input transients as high as 60V. Running at a fixed frequency of 200kHz, the LT1766 can be externally synchronized to clock frequencies up to 700kHz. A shutdown pin provides an accurate 2.38V undervoltage lockout threshold in addition to a 0.4V threshold for micropower shutdown (25 μ A). The LT1766 is provided in a small 16-pin SSOP (GN16) package with fused corner pins to improve thermal performance.

Efficiency

A typical high input voltage application, a 42V to 5V converter, is shown in Figure 1. To achieve high efficiency at high input voltages, fast output-switch edge rates are required; the LT1766 achieves edge rates of 1.2V/ns (rise) and 1.7V/ns (fall). In addition, light loads at high input voltages require minimal quiescent current to be drawn from the input. A BIAS pin allows the internal control circuitry to be supplied from the regulated output if greater than 3V. The peak efficiency for a 42V to 5V conversion is > 80%.

The LT1766 is also capable of excellent efficiencies at lower input voltages. The peak efficiency for a 12V-to-5V conversion is >90% (Figure 2). One key to achieving

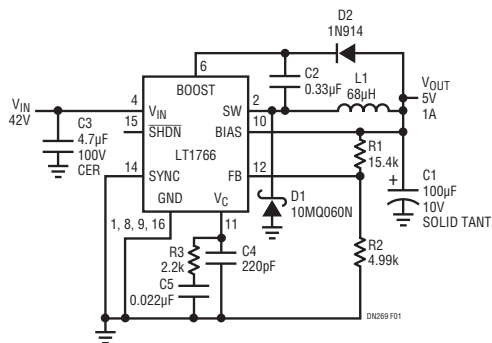

C1: AVX D CASE 100 μ F 10V TPSD107M010R0100 (207) 282-5111
 C2: AVX 0.33 μ F X7R 16V 0805YC334KAT1A (803) 946-0362
 C3: MARCON 4.7 μ F 100V TCCR70E2A475M (708) 913-9980
 C4: AVX 220pF X7R 50V 0805A221KAT
 C5: AVX 0.022 μ F X7R 16V 0805YC223KAT
 D1: INTERNATIONAL RECTIFIER 60V 1.5A SCHOTTKY 10M0Q060N
 D2: ZETEX FMMD914TA
 L1: COILTRONICS 68H UP2-680 (561) 241-7876

Figure 1. 42V to 5V Step-Down Converter

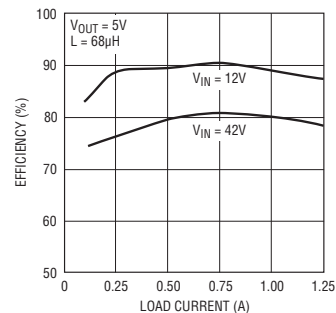

Figure 2. LT1766 Efficiency

high efficiency for low input-to-output voltage conversions is to use a low resistance saturating switch. A prebiased capacitor, connected between the BOOST and SW pins, generates a boost voltage above the input supply during switching. Driving the switch from this boost voltage allows the 200mΩ power switch to fully saturate. Furthermore, an output voltage as low as 3.3V is capable of generating the required boost supply.

Output Ripple Voltage

The output ripple voltage for the circuit in Figure 1, using a tantalum output capacitor, is approximately 35mV_{P-P} (Figure 4). Peak-to-peak output ripple voltage is the sum of a triwave (created by peak-to-peak ripple current in the inductor times the ESR of the output capacitor) and a square wave (created by the parasitic inductance (ESL) of the output capacitor times ripple current slew rate). A significant reduction in output ripple voltage to 12mV_{P-P} can be achieved using a ceramic output capacitor (Figure 4). With negligible ESR, the ceramic output capacitor reduces the portion of output ripple voltage generated by inductor ripple current times capacitor

ESR. The useful feedback response zero provided by the tantalum output capacitor ESR for loop stabilization is now replaced by a capacitor inserted across R1 in the feedback resistor network.

Peak Switch Current

The LT1766 maintains peak switch current over the full duty cycle range. Although the LT1766 uses a current mode architecture to provide fast transient response and good loop stability, the LT1766 peak switch current does not fall off at high duty cycles, unlike most current mode converters. The fall off of peak switch current in most current mode converters is due to the addition of slope compensation to the current sensing loop of the converter in order to prevent subharmonic oscillations for duty cycles above 50%. The LT1766 uses patented circuitry to cancel the effect of slope compensation on peak switch current without affecting frequency compensation. For high duty cycle requirements, this is a significant benefit over typical current mode converters with similar peak switch current limits.

LT1766 Features

- Wide Input Range: 5.5V to 60V
- 1.5A Peak Switch Current
- Small 16-Pin SSOP Package
- Constant 200kHz Switching Frequency
- 0.2Ω Saturating Switch
- Peak Switch Current Maintained Over Full Duty Cycle Range
- 25μA Shutdown Current
- 1.2V Feedback Reference
- Easily Synchronizable Up to 700kHz

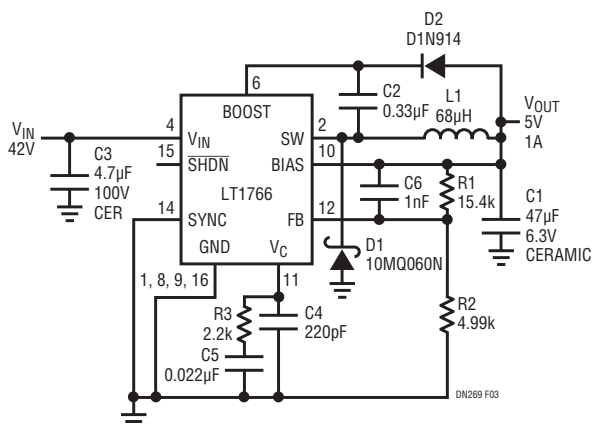

- C1: TAIYO YUDEN 47μF X5R 6.3V JMK4328J476MM
 C2: AVX 0.33μF X7R 16V 0805YC334KAT1A (803) 946-0362
 C3: MARCON 4.7μF 100V TCCR70E2A475M (708) 913-9980
 C4: AVX 220pF X7R 50V 0805A221KAT
 C5: AVX 0.022μF X7R 16V 0805YC223KAT
 C6: AVX 1000pF X7R 50V 08055C102KAT
 D1: INTERNATIONAL RECTIFIER 60V 1.5A SCHOTTKY 10MQ060N
 D2: ZETEX FMMD914TA
 L1: COILTRONICS 68H UP2-680 (561) 241-7876

Figure 3. 42V to 5V (All Ceramic) Step-Down Converter with Low Output Ripple Voltage

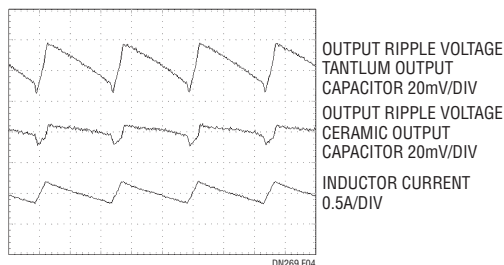

Figure 4. Output Ripple Voltage Comparison (Tantalum vs Ceramic Output Capacitor)

Data Sheet Download

www.linear.com

For applications help,
call (408) 432-1900

Linear Technology Corporation
 1630 McCarthy Blvd., Milpitas, CA 95035-7417
 (408) 432-1900 • FAX: (408) 434-0507 • www.linear.com

dn269_conv LT/TP 1001 341.5K • PRINTED IN THE USA

LINEAR
 TECHNOLOGY
 © LINEAR TECHNOLOGY CORPORATION 2001