



DESIGN NOTES

Basic Flashlamp Illumination Circuitry for Cellular Telephones/Cameras – Design Note 345

Jim Williams

Introduction

Next generation cellular telephones will include high quality photographic capability. Flashlamp-based lighting is crucial for good photographic performance. A previous full-length Linear Technology publication detailed flash illumination issues and presented flash circuitry equipped with “red-eye” reduction capability.^{1,2} Some applications do not require this feature; deleting it results in an extremely simple and compact flashlamp solution.

Flashlamp Circuitry

Figure 1’s circuit consists of a power converter, flashlamp, storage capacitor and an SCR-based trigger. In operation the LT[®]3468-1 charges C1 to a regulated 300V at about 80% efficiency. A “trigger” input turns the SCR on, depositing C2’s charge into T2, producing a high voltage trigger event at the flashlamp. This causes the lamp to conduct high current from C1, resulting in an intense flash of light. LT3468-1 associated waveforms,

appearing in Figure 2, include trace A, the “charge input,” going high. This initiates T1 switching, causing C1 to ramp up (trace B). When C1 arrives at the regulation point, switching ceases and the resistively pulled-up “DONE” line drops low (trace C), indicating C1’s charged state. The “TRIGGER” command (trace D), resulting in C1’s discharge via the lamp, may occur any time (in this case ≈600ms) after “DONE” goes low. Normally, regulation feedback would be provided by resistively dividing down the output voltage. This approach is not acceptable because it would require excessive switch cycling to offset the feedback resistor’s constant power drain. While this action would maintain regulation, it would also drain excessive power from the primary source, presumably a battery. Regulation is instead obtained by monitoring T1’s flyback pulse characteristic, which reflects T1’s secondary amplitude. The output

Note 1. See LTC Application Note 95, “Simple Circuitry for Cellular Telephone/Camera Flash Illuminator” by Jim Williams and Albert Wu, March 2004.

Note 2. “Red-eye” in a photograph is caused by the human retina reflecting the light flash with a distinct red color. It is eliminated by causing the eye’s iris to constrict in response to a low intensity flash immediately preceding the main flash.

LT, LT, LTC, LTM, Linear Technology and the Linear logo are registered trademarks of Linear Technology Corporation. All other trademarks are the property of their respective owners.

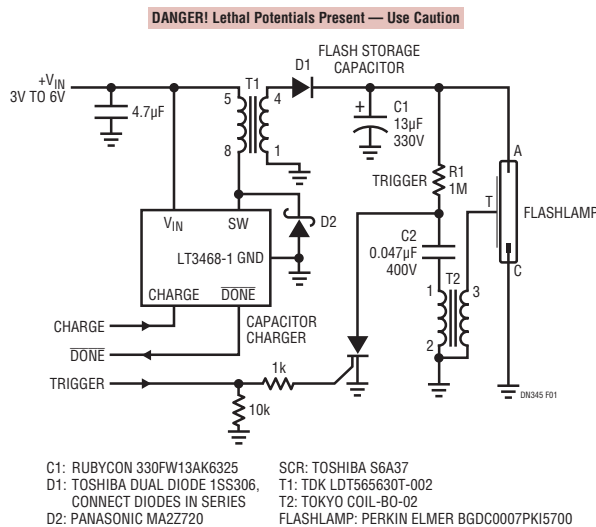

Figure 1. Complete Flashlamp Circuit Includes Capacitor Charging Components, Flash Capacitor C1, Trigger (R1, C2, T2, SCR) and Flashlamp. TRIGGER Command Biases SCR, Ionizing Lamp via T2. Resonant C1 Discharge Through Lamp Produces Light

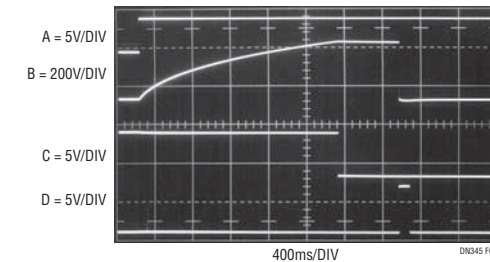

Figure 2. Capacitor Charging Waveforms Include Charge Input (Trace A), C1 (Trace B), DONE Output (Trace C) and TRIGGER Input (Trace D). C1’s Charge Time depends Upon Its Value and Charge Circuit Output Impedance. TRIGGER Input, Widened for Figure Clarity, May Occur Any Time After DONE Goes Low

voltage is set by T1's turns ratio. This feature permits tight capacitor voltage regulation, necessary to ensure consistent flash intensity without exceeding lamp energy or capacitor voltage ratings. Also, flashlamp energy is conveniently determined by the capacitor value without any other circuit dependencies.

Figure 3 shows high speed detail of the high voltage trigger pulse (trace A), the flashlamp current (trace B) and the light output (trace C). Some amount of time is required for the lamp to ionize and begin conduction after triggering. Here, 3 μ s after the 4kV_{p-p} trigger pulse, flashlamp current begins its ascent to over 100A. The current rises smoothly in 3.5 μ s to a well defined peak before beginning its descent. The resultant light produced rises more slowly, peaking in about 7 μ s before decaying. Slowing the oscilloscope sweep permits capturing the entire current and light events. Figure 4 shows that light output (trace B) follows lamp current (trace A) profile, although current peaking is more abrupt. Total event duration is \approx 200 μ s with most energy expended in the first 100 μ s.

Conclusion

The circuit presented constitutes a basic, but high performance, flash illumination solution. Its low power, small size and few components suit cellular telephone/camera applications where size and power drain are important. It provides a practical, readily adaptable path to accessing flashlamp-based illumination's photographic advantages.

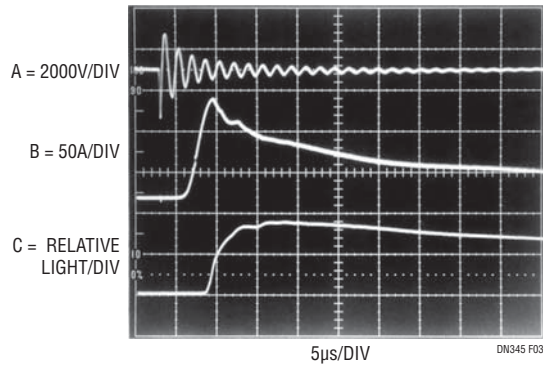

Figure 3. High Speed Detail of Trigger Pulse (Trace A), Resultant Flashlamp Current (Trace B) and Relative Light Output (Trace C). Current Exceeds 100A After Trigger Pulse Ionizes Lamp

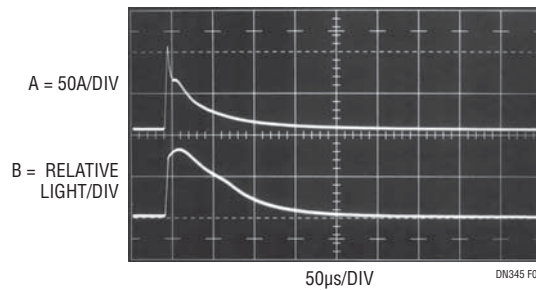

Figure 4. Photograph Captures Entire Current (Trace A) and Light (Trace B) Events. Light Output Follows Current Profile Although Peaking is Less Defined. Waveform Leading Edges Enhanced for Figure Clarity

Data Sheet Download

www.linear.com

For applications help,
call (408) 432-1900

Linear Technology Corporation
1630 McCarthy Blvd., Milpitas, CA 95035-7417
(408) 432-1900 • FAX: (408) 434-0507 • www.linear.com

dn345f_conv LT/TP 0904 305K • PRINTED IN THE USA

© LINEAR TECHNOLOGY CORPORATION 2004