

40V MICROPOWER SOT-23 BUCK REGULATOR WITH
INTEGRATED BOOST AND CATCH DIODES

DESCRIPTION

Demonstration circuit 716 is a 40V micropower SOT-23 buck regulator featuring the LT[®]3470. The board is optimized for 5V output at up to 200mA load current for a steady state input voltage range of 7V to 40V. With its wide input voltage range, high efficiency internal power switch, low dropout operation, hysteretic current-mode, integrated boost and catch diodes and tiny SOT-23 package, the LT3470 is a very versatile and powerful IC for DC/DC converters that require extremely compact space, high efficiency and high input voltage.

The LT3470 hysteretic control scheme allows all of the components to be small, surface mount devices while providing minimum output ripple voltage at all load currents. The current-mode control topology creates fast transient response and good loop stability with a minimum number of external components. The low resistance internal power switch achieves high efficiencies of up to 82% at 12V input. The shutdown jumper can be used to place the part in micropower shutdown, reducing supply current to less

than 1 μ A by driving the pin low. The internal boost and catch diodes simplify layout and reduce component count, providing the smallest solution possible.

The LT3470 datasheet gives a complete description of the part, operation and applications information. The datasheet must be read in conjunction with this Quick Start Guide for demonstration circuit 716. In particular, the datasheet section on 'Thermal Calculations' is important for estimating whether a given application's combination of input voltage, load current, ambient temperature and frequency will cause the LT3470 to exceed its absolute maximum rated junction temperature. The LT3470 is assembled in a small low profile SOT-23 ThinSOT package. Proper board layout is essential for maximum thermal performance. See the datasheet section 'Layout Considerations'.

Design files for this circuit board are available. Call the LTC factory.

LT is a trademark of Linear Technology Corporation

QUICK START PROCEDURE

Demonstration circuit 716 is easy to set up to evaluate the performance of the LT3470. Refer to Figure 1 for proper measurement equipment setup and follow the procedure below:

NOTE: Make sure that the input voltage does not exceed 40V.

NOTE: The shutdown jumper shunt is required to be placed in the shutdown position or the VOUT ENABLE position for proper operation.

NOTE: Do not hot-plug the input voltage terminal VIN. The absolute maximum voltage on VIN is 40V and hot-plugging a power supply through wire leads to the demonstration circuit can cause the voltage on the extremely low-ESR ceramic input capacitor to ring to twice its DC value. In order to protect the IC, a higher ESR Aluminum Electrolytic capacitor is placed at the input terminals. This may protect against some, but not all, input transients due to hot-plugging with a power supply. See *Application Note 88* for more details.

NOTE: Connect the power supply (with power off), load, and meters as shown in Figure 1.

1. After all connections are made, turn on input power and verify that the output voltage is 5V.

NOTE: If the output voltage is too low, temporarily disconnect the load to make sure that the load is not set too high.

2. Once the proper output voltages are established, adjust the load within the operating range and observe the output voltage regulation, ripple voltage, efficiency and other parameters.

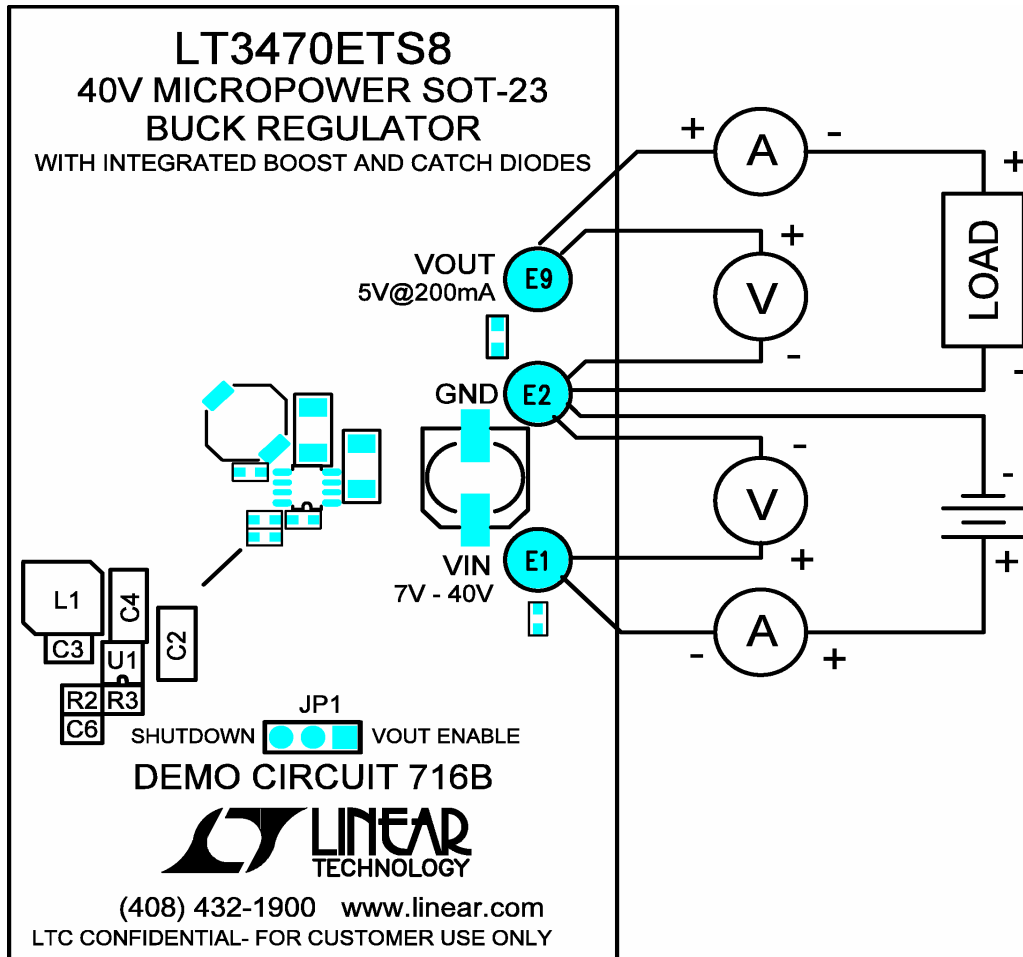

INSTALL SHUNT AT JP1: PINS 1 & 2 = VOUT ENABLE
PINS 2 & 3 = SHUT DOWN

Figure 1. Proper Measurement Equipment Setup

