

Tiny, Highly Flexible, Dual Boost/Inverter Tracks Supplies

Design Note 357

Jeffrey Huang

Introduction

Linear Technology's **LT[®]3471** is a space saving and extremely versatile dual switching regulator available in a tiny 3mm × 3mm DFN package. With a 2.4V to 16V input range, the device can easily implement any combination of boost, inverting and SEPIC topologies to generate two positive and/or negative outputs up to ±40V. It can readily make the two output voltages track each other with minimal additional circuitry, or it can independently regulate the outputs, thus saving space by replacing two separate ICs. Either way, the LT3471 fits into tight spaces and is easily adaptable for a wide range of applications.

LT3471 Features

The LT3471 combines two independent, in-phase, 1.3A, 42V switches with error amplifiers that can sense to ground, providing boost and inverting capabilities. Both inputs of each error amplifier are available as high impedance feedback pins with a typical bias current of only 60nA. An accurate 1.00V reference is also pin accessible.

The LT3471 switches at a fixed 1.2MHz which allows for the use of tiny, low profile inductors and capacitors. Its internally compensated, current mode PWM architecture yields low, predictable output noise that is easy to filter. Additionally, the device provides a programmable soft-start function that requires only a simple external RC circuit to mitigate high inrush current.

Easy-to-Implement ±15V Dual Tracking Supplies

Figure 1 shows a Li-Ion to ±15V dual tracking supply application, highlighting the versatility of the LT3471 by taking advantage of the accessible error amplifier inputs and reference voltage. The circuit generates well-regulated ±15V outputs that track each other with switchers 1 and 2 in boost and inverting configurations, respectively.

The two converters can talk to each other through their shared external feedback resistor network, specifically R1. When regulating, the control loop of switcher 1 servos

LT, LT, LTC, LTM, Linear Technology and the Linear logo are registered trademarks of Linear Technology Corporation. All other trademarks are the property of their respective owners.

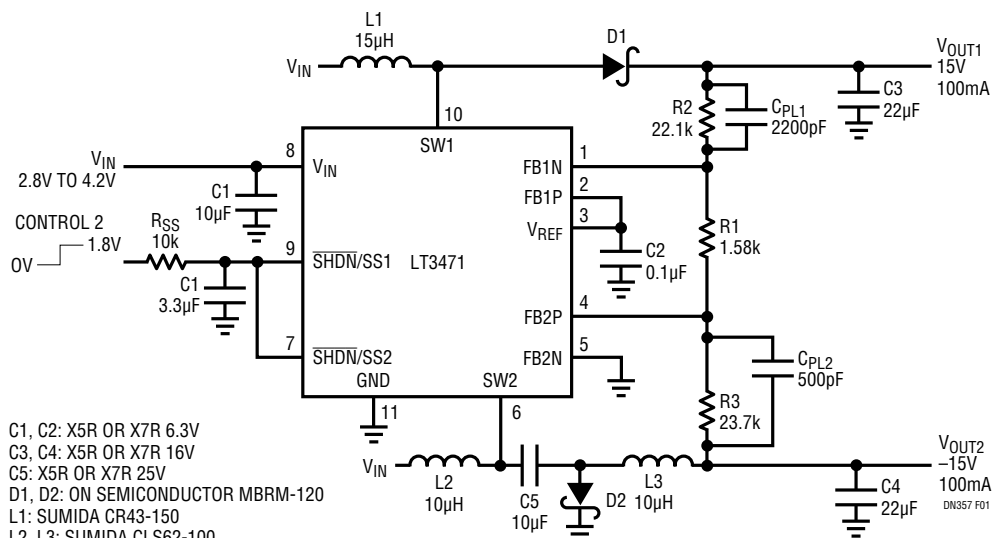

Figure 1. Li-Ion to ±15V Dual Tracking Supplies

FB1N to 1V while that of switcher 2 serves FB2P to ground. Selecting the value of R2 to be $(14 \cdot R1)$ and R3 to be $(15 \cdot R1)$ produces $\pm 15V$ outputs. In this way, the magnitudes of V_{OUT1} and V_{OUT2} track each other; that is, a change in the +15V output causes a similar change in the -15V output, and vice versa. Figure 2 shows the circuit efficiency.

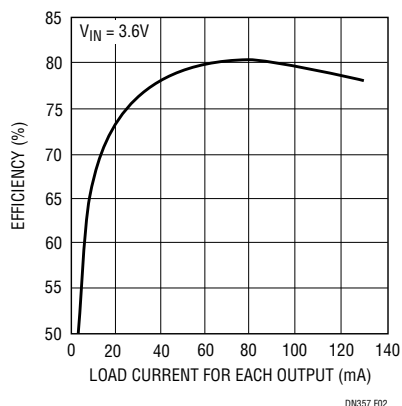

Figure 2. Efficiency of the Circuit in Figure 1

The interaction between the two converters may compromise the stability of each. To prevent this, phase lead capacitors C_{PL1} and C_{PL2} improve the phase margin of both switchers. Figure 3 shows the transient response of the circuit under a constant 50mA load on V_{OUT1} and 50mA load step on V_{OUT2} . The upper waveform depicts the 15V output tracking the clean, damped response of the -15V output, the middle waveform. The output voltages remain within 0.3% of their nominal values during the step transient. V_{OUT2} similarly tracks V_{OUT1} under a load step on switcher 1 and constant load on switcher 2.

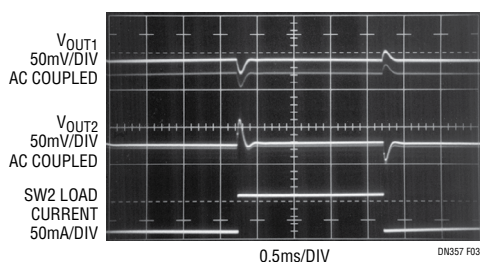

Figure 3. Transient Response of the Circuit in Figure 1

Both switchers implement a programmable soft-start feature. The RC circuit at the SS1 and SS2 pins in Figure 1 sets the input current ramp rate. Figures 4

and 5 show the effect of soft-start on the output voltages (top two traces) and input current (bottom trace). Figure 4 depicts the start-up waveforms of the circuit without soft-start (C_{SS} removed). The output voltages reach $\pm 15V$ very quickly but the inrush current sharply peaks above 2A. With soft-start, as shown in Figure 5, the input current peaks slightly to about 500mA, while the output voltages comfortably rise and settle to their steady-state values. In both cases, V_{OUT1} and V_{OUT2} track each other.

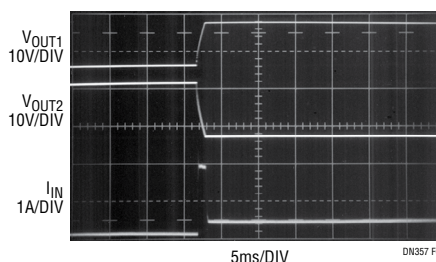

Figure 4. Without Soft-Start (C_{SS} Removed in Figure 1), the Output Voltages Quickly Reach Regulation, but the LT3471 Draws Very High Inrush Current

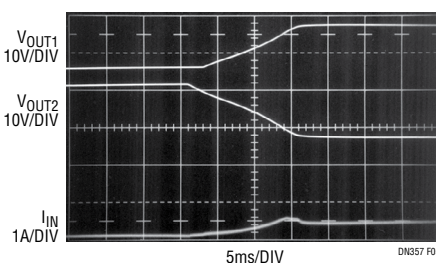

Figure 5. With Soft-Start Enabled (via the $R_{SS} C_{SS}$ Network in Figure 1), the Output Voltages Slowly Reach Regulation, While the Controlled Inrush Current Safely Ramps Up with Little Peaking

Conclusion

The LT3471 is a tiny, dual switching regulator easily configurable for a broad array of applications, including organic and white LED drivers, TFT-LCD bias supplies and other portable device and medical diagnostic equipment functions. A flexible pinout makes it simple to generate any combination of two positive and/or negative outputs. The LT3471's small footprint and versatile, 2-switcher capability make it a great fit in a variety of power management solutions.

Data Sheet Download

www.linear.com/LT3471

For applications help,
call (408) 432-1900