

## Tighten Supply Regulation for 2A USB Devices by Dynamically Compensating for Voltage Drops in Wiring and Connectors

Design Note 1029

Tom Hack

### Introduction

These days, the Universal Serial Bus (USB) is commonly used to power tablet computers and high rate cell phone battery chargers—applications never envisioned at the inception of the USB standard in the mid-1990s. The USB standard has changed significantly over this time. For instance, USB 3.0 requires up to 900mA (six, 150mA unit loads) during high bandwidth communication. A dedicated charging port can supply as much as 1.8A.

Such high, and highly variable, load currents can produce significant and unpredictable voltage drops in wiring and connectors, lowering the performance of the device. Virtual remote sensing senses losses in the line in real time, automatically adapting to changes in load current, line resistance, connector aging and temperature variation. The result is improved voltage regulation and increased device reliability.

### Virtual Remote Sensing (VRS) Power Supply

Figure 1 shows a 2A USB power supply for automotive applications using a buck switching regulator and the [LT4180](#) virtual remote sense controller. The power supply produces a 5V, 2A output from a nominal input voltage

of 12V. To simplify the schematic, the protection circuitry for load dump, reverse battery, 2-battery jump, spikes and noise are not shown (consult Linear Technology's "[Automotive Electronics Solutions](#)" brochure for further information.) The nominal switching frequency is set above 455kHz to avoid interference in the IF of various RF devices. It can be raised to 2MHz to avoid interfering with AM and Travelers Information Station broadcasts, but at the expense of some power supply efficiency.

This design corrects for total wiring and connector resistances of  $0.1\Omega$  to  $0.4\Omega$  and load currents from zero to 2A. Thirty randomly selected LT4180 virtual remote sense devices were tested in this design with wiring and connector resistances of  $0.1\Omega$ ,  $0.2\Omega$ , and  $0.4\Omega$ , and zero to 2A load currents. With  $0.1\Omega$  USB cable and connector resistance, none of the thirty devices exhibited more than  $\pm 3\%$  variation from nominal output voltage. For total resistances of  $0.2\Omega$  and  $0.4\Omega$ , the worst-case variation in output voltage for all load current and devices never exceeded  $\pm 3.4\%$  and  $\pm 4.6\%$ , respectively.

LT, LTC, LTM, Linear Technology, the Linear logo and  $\mu$ Module are registered trademarks of Linear Technology Corporation. All other trademarks are the property of their respective owners.

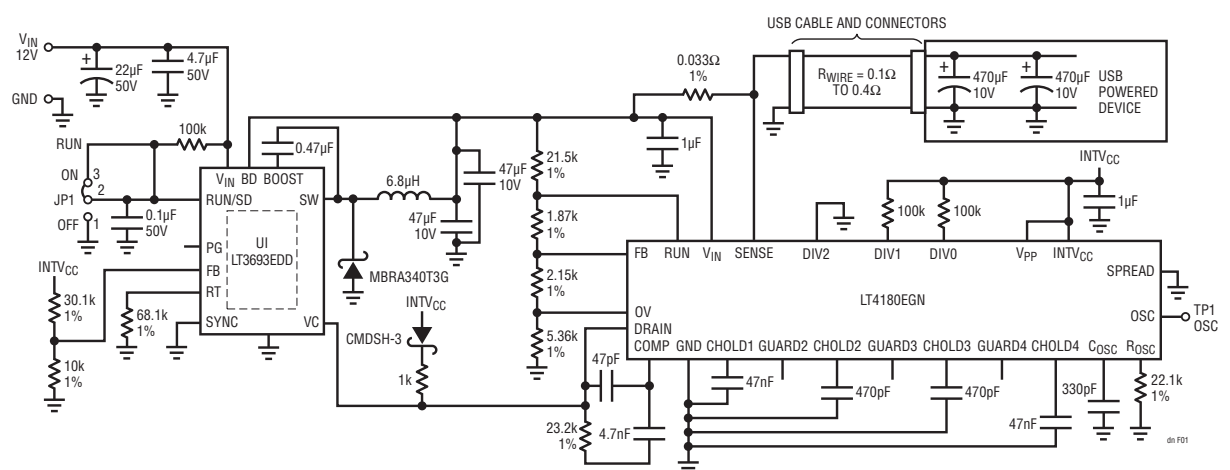
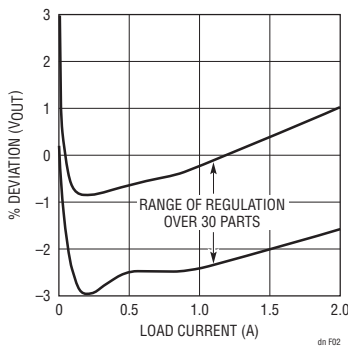
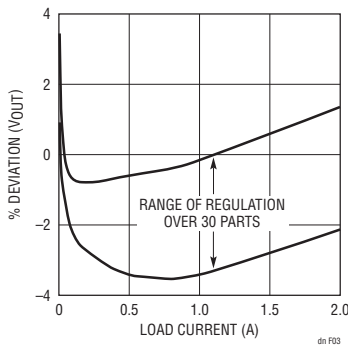

Figure 1. A 2A USB Automotive Power Supply Using Virtual Remote Sensing



**Figure 2. Worst-Case Load Regulation with  $R_{WIRE} = 0.1\Omega$**



**Figure 3. Worst-Case Load Regulation with  $R_{WIRE} = 0.2\Omega$**

### Adding VRS to Existing Devices and Designs

Virtual remote sensing requires an AC short at the regulation point for best results, which may not be feasible in some existing designs. For example, in Figure 4, a typical USB device is connected directly to the power supply shown in Figure 1. In this case, regulation is maintained up to the USB A receptacle, but the supply cannot correct for additional voltage drops beyond this point.

Fortunately, the simple trick shown in Figure 5 removes most of this error. By adding a resistor,  $R_{COMP}$ , in series with the decoupling capacitor,  $C_{LOAD}$ , the voltage at the USB A receptacle rises with increasing load current, thus compensating for any additional voltage drop in the USB device caused by increasing load current.

Figure 6 shows typical results with  $0.2\Omega$  USB cable resistance, and  $0.1\Omega$  USB device cable resistance. The connector uses two  $470\mu F$  capacitors (for a total  $C_{LOAD}$  equal to  $940\mu F$ ) in series with  $R_{COMP} = 0.1\Omega$ . Without  $R_{COMP}$ , load regulation would be about  $\pm 5.2\%$ . Adding

$R_{COMP}$  improves load regulation to approximately  $\pm 3.2\%$ .

Results vary depending on how well  $R_{COMP}$  matches the resistance of the cable between the USB power device and the decoupling network ( $R_{COMP}/C_{LOAD}$ ). Any capacitance internal to the USB powered device (if it becomes a significant fraction of  $C_{LOAD}$ ) may also degrade the results.

One final note: adding  $R_{COMP}$  reduces the filtering effectiveness of  $C_{LOAD}$ , resulting in increased power supply ripple.

### Conclusions

Virtual remote sensing significantly improves load regulation in USB products where unknown wiring resistances would otherwise degrade regulation at the device. By dynamically adapting to changes in load current, line resistance, connector aging and temperature variation, voltage tolerances are improved, ensuring consistent and reliable operation.

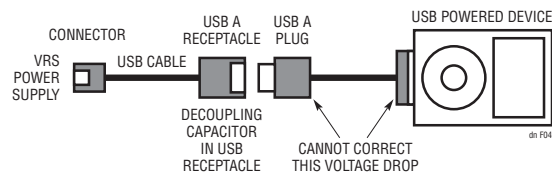

**Figure 4. Incomplete Wiring Drop Correction**

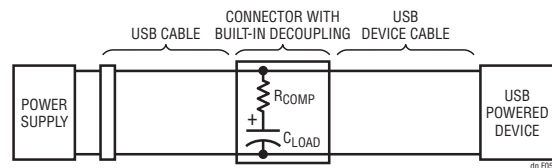

**Figure 5. Correcting for Downstream Wiring Voltage Drops**

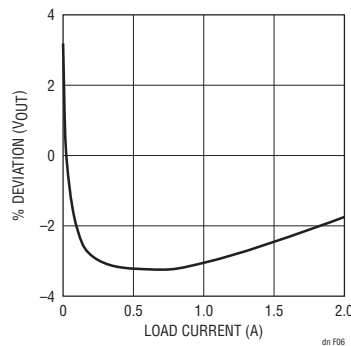

**Figure 6. Typical Load Regulation at the USB Powered Device Depicted in Figure 5**

Data Sheet Download

[www.linear.com/4180](http://www.linear.com/4180)

For applications help,  
call (408) 432-1900, Ext. 3231