

LTC1433 Low Noise Current Mode Step-down DC/DC Converter

DESCRIPTION

This demonstration circuit is a step-down (buck) regulator using the LTC[®]1433. Exclusive use of surface mount components results in a highly efficient application in a small board space. The output voltages are selectable via a programmable pin for 3.3V and 5V without additional components. The board can also be set up to meet any output voltage requirement through an additional resistive divider. This demo board highlights the capabilities of the LTC1433, which uses a current mode PWM architecture to switch two internal P-channel power MOSFETs. This results in a power supply that has low ripple and fast transient response. The LTC1433 also features Linear Technology's Adaptive Power[™] output stage to provide

excellent efficiency at both low and high load currents without sacrificing constant-frequency operation. In dropout, the internal P-channel MOSFETs are turned on continuously (100% duty cycle) providing low dropout operation with V_{OUT} at V_{IN} . The part can also be shut down, in which case it draws about 15 μ A, making it ideal for current-sensitive applications. An onboard low-battery detector allows the user to monitor the input supply through an external resistive divider. This divided voltage is compared with an internal 1.19V reference voltage. **Gerber files for this circuit board are available. Call the LTC factory.**

LT, LTC and LT are registered trademarks of Linear Technology Corporation. Adaptive Power is a trademark of Linear Technology Corporation.

PERFORMANCE SUMMARY

SYMBOL	PARAMETER	CONDITIONS	JUMPER POSITION	VALUE
V_{IN}	Input Working Voltage Range		All	3.5V to 12.5V
V_{OUT}	Output Voltage		Down Up Remove	5V \pm 0.12V 3.3V \pm 0.08V 1.19V \pm 0.012V
I_Q	Typical Supply Current	$V_{IN} = 12.5V$, $LBI = 6V$, $I_{OUT} = 0mA$ $RUN/SS = 0V$, $LBI = 6V$, $I_{OUT} = 0mA$ $RUN/SS = 0V$, $LBI = 0V$, $I_{OUT} = 0mA$	All All All	470 μ A 35 μ A 15 μ A

TYPICAL PERFORMANCE CHARACTERISTICS AND BOARD PHOTO

Efficiency vs Load Current
 $V_{OUT} = 3.3V$

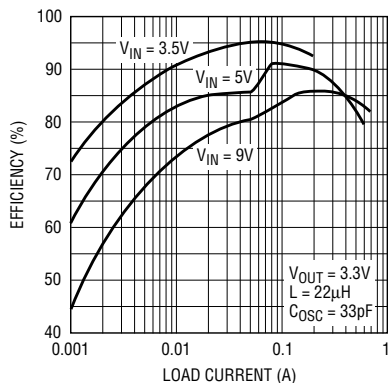

DC144 G01

Efficiency vs Load Current
 $V_{OUT} = 5V$

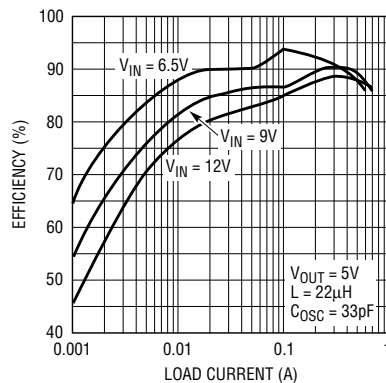

DC144 G02



DEMO MANUAL DC144

NO DESIGN SWITCHER

PERFORMANCE SUMMARY

SYMBOL	PARAMETER	CONDITIONS	JUMPER POSITION	VALUE
I_{OUT}	Minimum Output Current	$V_{IN} = 6.5V, V_{OUT} = 5V$ $V_{IN} = 5V, V_{OUT} = 3.3V$	Down Up	400mA 400mA
V_{RIPPLE}	Typical Output Ripple	$I_{OUT} = 400mA, V_{IN} = 12.5V$	All	30mV _{p-p}
ΔV_{OUT}	Typical Load Regulation	$0mA < I_{OUT} < 0.4A, V_{IN} = 12.5V$	All	0.5%
V_{LBTP}	Low-Battery Trip Point		All	$1.19 \pm 0.1V$

PACKAGE AND SCHEMATIC DIAGRAMS

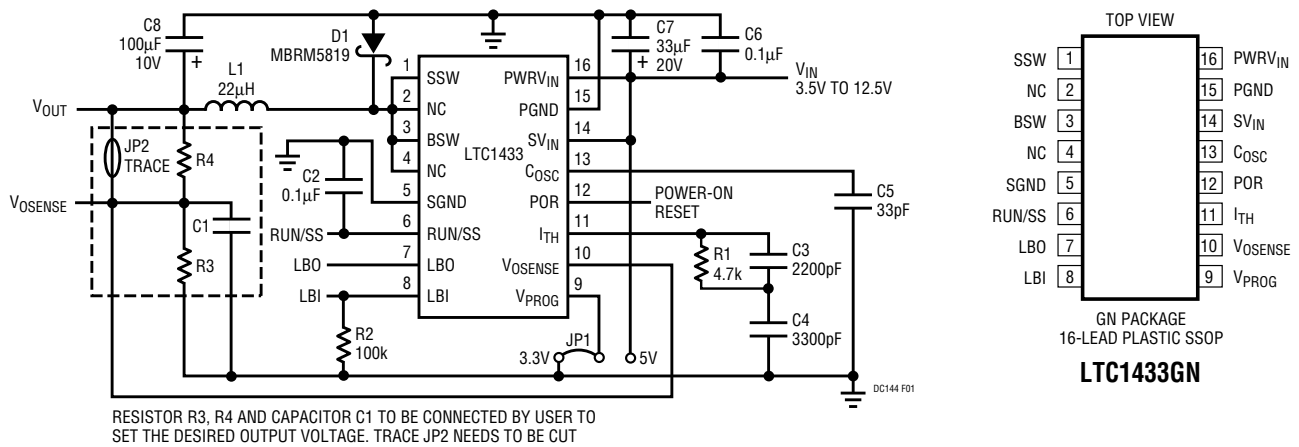

Figure 1. Demo Board Schematic

PARTS LIST

REFERENCE DESIGNATOR	QUANTITY	PART NUMBER	DESCRIPTION	VENDOR	TELEPHONE
C2, C6	2	08055C104MAT1A	0.1µF 50V 20% X7R Capacitor	AVX	(803) 946-0362
C3	1	08055C222MAT1A	2200pF 50V 20% X7R Capacitor	AVX	(803) 946-0362
C4	1	08055C332MAT1A	3300pF 50V 20% X7R Capacitor	AVX	(803) 946-0362
C5	1	08055A330JAT1A	33pF 50V 5% NPO Capacitor	AVX	(803) 946-0362
C7	1	TPSD336M020R0200	33µF 20V 20% Tantalum Capacitor	AVX	(207) 282-5111
C8	1	TPSD107M010R0080	100µF 10V 20% Tantalum Capacitor	AVX	(207) 282-5111
D1	1	MBRM5819T3	40V 1A Schottky Diode	Motorola	(602) 244-3576
JP1	1	2802S-03G2	0.079"cc 3-Pin Jumper	COMM CON	(818) 301-4200
JP1	1	CCIJ2mm-138-G	0.079cc 0.138" Shunt	COMM CON	(818) 301-4200
J1	1	3801S-05G1	5-Pin 1 Row 0.1cc Header Connector	COMM CON	(818) 301-4200
J2 to J6	5	1502-2	0.09" Turret Test Point	Keystone	(718) 956-8900
L1	1	CD54-220	22µH 1A 20% Inductor	Sumida	(847) 956-0666
R1	1	CR21-472J-T	4.7k 0.1W 5% Chip Resistor	AVX	(803) 946-0524
R2	1	CR21-104J-T	100k 0.1W 5% Chip Resistor	AVX	(803) 946-0524
U1	1	LTC1433CGN	16-Pin Narrow SSOP DC/DC IC	LTC	(408) 432-1900

QUICK START GUIDE

Demonstration board DC144 is easy to set up for evaluation of the LTC1433. Please follow the procedure below for proper operation.

- Move jumper JP1 to the down position for 5V output or to the up position for 3.3V output. For other output voltages, remove the jumper, connect the appropriate resistive divider and cut trace JP2 on the board. For higher noise immunity, connect a 100pF capacitor (C1) across the lower leg of the resistive divider.
- The LBO pin is a current sinking pin. When the LBI pin goes below 1.19V the LBO pin will sink 1.6mA of current.
- The LBI pin is the low-battery detector input pin. Normally its input comes from the input voltage through a resistive

divider network (see Low-Battery Detector). A 100k resistor is connected between this pin and ground.

- For POR evaluation, connect a resistor from this pin to a supply. Do not exceed 12V on the supply.
- Connect the input power supply to the V_{IN} and GND terminals.
- Connect the load between the V_{OUT} and GND terminals. Refer to Figure 4 for proper measurement-equipment setup.
- To put this part in shutdown, connect the RUN/SS pin to ground. For further reduction in shutdown current, connect the LBI pin to ground.

OPERATION

The circuit shown in Figure 1 operates from input voltages of 3.5V to 12.5V. The output can be easily set for 3.3V or 5V by moving the jumper JP1. For other output voltages, the jumper should be removed and a trace should be cut. In addition, a resistive divider and a decoupling capacitor should be connected on the provided pads. The frequency of operation for the LTC1433 is set at 330kHz.

This demonstration unit is intended for the evaluation of the LTC1433 switching regulator IC and was not designed for any other purposes.

OPERATION

The LTC1433 uses the constant-frequency, pulse-width modulated current mode architecture shown in Figure 2. Current mode operation provides the well known advantages of clean start-up and excellent line and load regulation.

To obtain high efficiency and constant frequency at low load current, the LTC1433 uses the new Adaptive Power output stage. At low load current, gate-charge losses dominate. To reduce these losses, only the internal small P-channel MOSFET is used. At higher load current, both the small and large internal MOSFETs are turned on, because losses due to

the drops across the FETs are more significant than gate-charge losses. This is the principle behind Adaptive Power mode operation. On the efficiency plot, the transition point where the large FET is used is represented by a small kink.

The LTC1433 operates as follows: the internal P-channel power MOSFETs are turned on during each cycle when the oscillator sets the latch (FF3) and turned off when the current comparator (I_{COMP}) resets it. The peak inductor current at which the I_{COMP} resets the latch is controlled by the voltage on the I_{TH} pin, which is the output of the error amplifier (GM). Pins V_{PROG} and V_{OSENSE} allow GM to receive an output feedback voltage (V_{FB}) from either the internal or external resistive divider. When the load current increases, it causes a slight decrease in V_{FB} relative to the 1.19V reference, which in turn causes the I_{TH} voltage to increase until the average inductor current matches the new load current.

LOW-BATTERY DETECTOR

The low-battery indicator senses the input voltage through an external resistive divider. This divided voltage connects to the (-) input of a voltage comparator (Pin 8), which is compared with a 1.19V reference voltage. On the demo

OPERATION

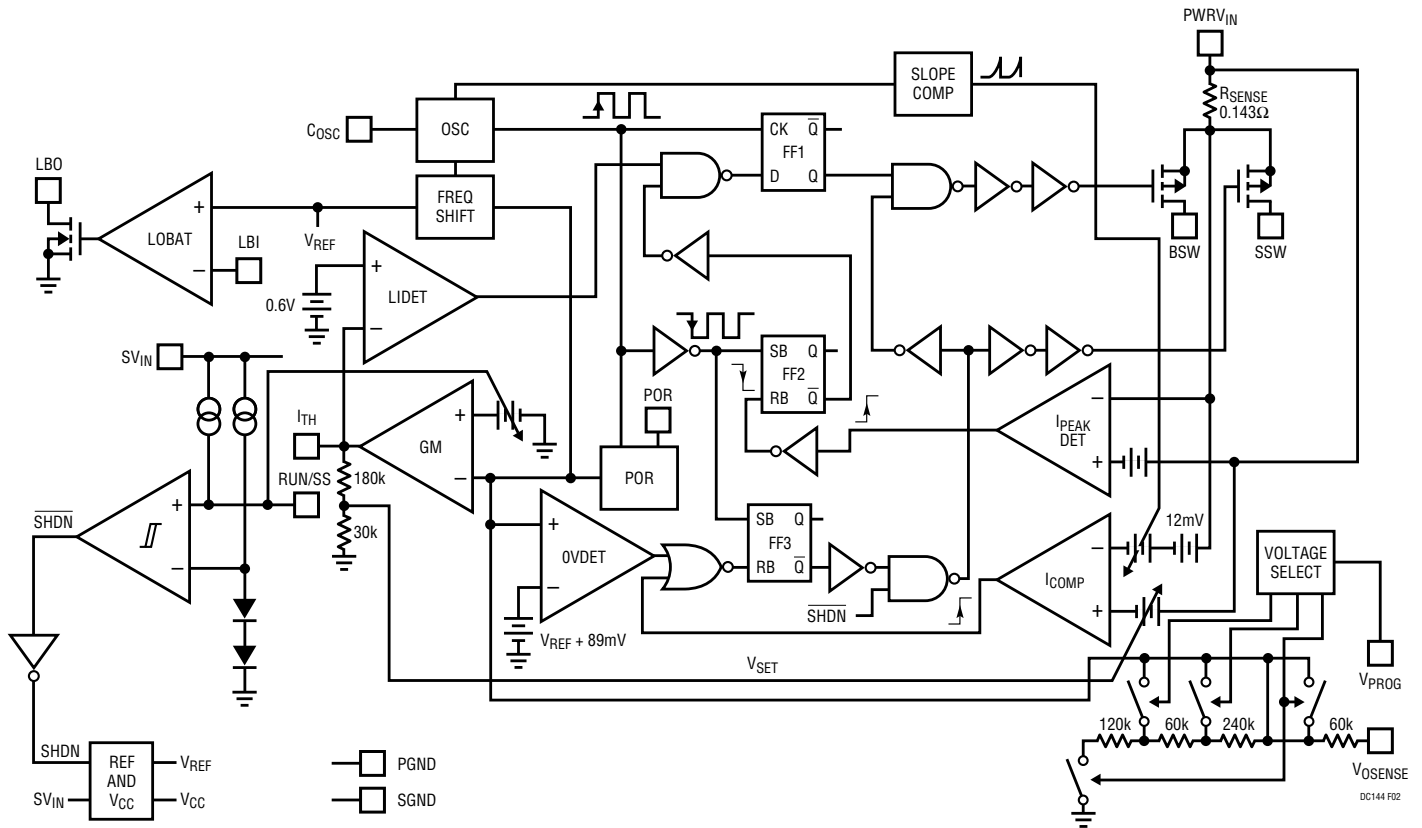

Figure 2. LTC1433 Block Diagram

board, a 100k resistor is connected as the lower leg of the divider. Because the current going into Pin 8 is negligible, the following expression can be used for setting the trip limit:

$$V_{LBTRIP} = 1.19 \left(1 + \frac{R_{TRIP}}{100,000} \right)$$

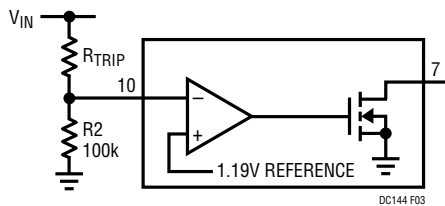

Figure 3. Low-Battery Comparator

POWER-ON RESET FUNCTION

The power-on reset function serves to indicate whether the switching regulator output voltage is close to regulation. An external pull-up resistor is required on the POR pin (Pin 12). When the power is first applied or when coming out of

shutdown, the POR output is pulled to ground. When the output voltage rises above 5% below the regulated output value, an internal counter starts. After counting 2^{16} (65,536) clock cycles, the POR's pull-down device turns off.

The POR output will go low whenever the output voltage drops below 7.5% of its regulated value for longer than approximately $30\mu s$, signaling an out-of-regulation condition.

HOW TO MEASURE VOLTAGE REGULATION

When trying to measure voltage regulation, remember that all measurements must be taken at the point of regulation. This point is where the LTC1433's control loop looks for the information to keep the output voltage constant. This information occurs between Pin 10 and Pin 5 of the LTC1433. These points correspond to the output terminals of the demonstration board. Test leads should be attached to these terminals. **Measurements should not be taken at the end of test leads at the load.** Refer to Figure 4 for proper monitoring equipment configuration.

OPERATION

This applies to line regulation (input-to-output voltage regulation) as well as load regulation tests. In doing line regulation tests, always look at the input voltage across the input terminals.

For the purposes of these tests, the demonstration circuit should be fed from a regulated DC bench supply so additional variation on the DC input does not add an error to the regulation measurements.

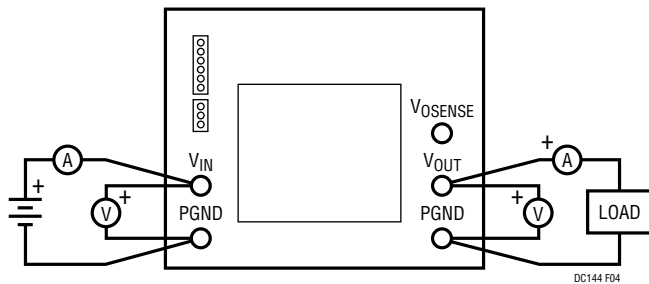

Figure 4. Correct Measurement Setup

RIPPLE MEASUREMENT

When measuring output ripple, it is best to measure directly across the output terminals.

As in the regulation tests, the supply must be fed from a regulated DC source so that ripple on the input to the circuit under test does not add to the output ripple, causing errors in the measurement.

The technique used to measure the ripple is also important. Here is a list of things to do and not to do when using a scope probe:

1. DO NOT USE THE GROUND LEADS/CLIPS THAT ARE ATTACHED TO THE SCOPE PROBE!
2. DO ATTACH THE SHIELD OF THE PROBE BODY TO THE NEGATIVE SIDE OF THE OUTPUT CAPACITOR! DO NOT USE WIRE!
3. DO PUT THE TIP OF THE SCOPE PROBE DIRECTLY ON THE POSITIVE TERMINAL OF THE OUTPUT CAPACITOR.
4. DO NOT USE A PROBE WHOSE BODY IS NOT COMPLETELY SHIELDED.

Any unshielded lead, such as a ground lead on a scope probe, acts as an antenna for the switching noise in the supply; therefore any use of a ground lead will invalidate the measurement.

Be extremely careful to ensure that other sources of noise do not invalidate the measurement. Noise from the 60Hz power line that feeds the bench power supply powering the LTC1433 demonstration board can cause errors in the measurement. This noise (especially spikes) can propagate through the bench supply and appear on the ground of the demonstration unit. If this is a problem, a battery can be used to power the unit for ripple tests.

Be wary of ground loops. The input DC supply should float and the only ground should be that of the scope probe. Never float the oscilloscope, as this may present a safety hazard.

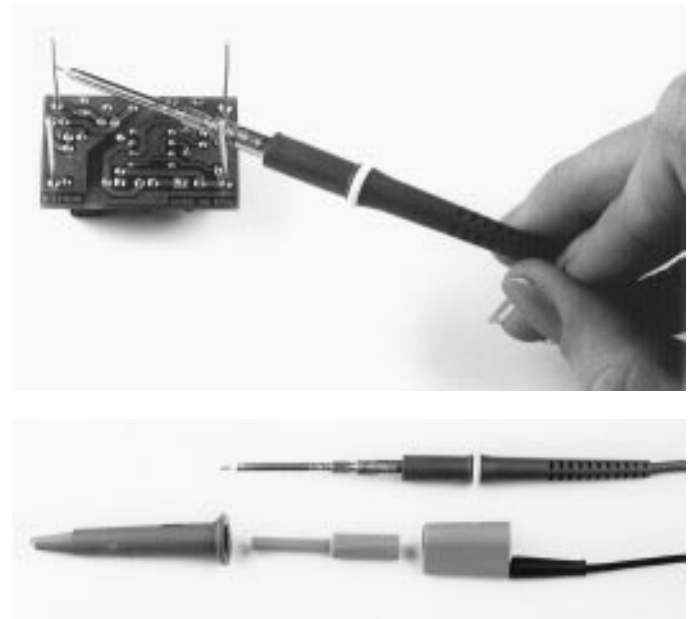

Figure 5. Scope Probe and Typical Measurement Setup

An alternate technique is to take a 50Ω or 75Ω piece of coax and solder the leads directly to the output capacitor. Keep the shield over the center conductor for as great a distance as possible. The center conductor can pick up stray radiation when it is not shielded, so minimize the length of exposed center conductor. The other end of the coax should have a BNC connector for attachment to the oscilloscope.

OPERATION

CHECKING TRANSIENT RESPONSE

Switching regulators take several cycles to respond to a step in DC (resistive) load current. When a load step occurs, V_{OUT} shifts by an amount equal to $(\Delta I_{LOAD})(ESR)$, where ESR is the effective series resistance of C_{OUT} . ΔI_{LOAD} also begins to charge or discharge C_{OUT} until the regulator loop adapts to the current change and returns V_{OUT} to its steady-state value. During this recovery time, V_{OUT} can be monitored for overshoot or ringing, which would indicate a stability problem. The external components shown in Figure 1's circuit will prove adequate for most applications.

A second, more severe transient is caused by switching in loads with large ($>1\mu F$) supply bypass capacitors. The discharged bypass capacitors are effectively put in parallel with C_{OUT} , causing a rapid drop in V_{OUT} . No regulator can deliver enough current to prevent this problem if the load switch resistance is low and it is driven quickly. The only solution is to limit the rise time of the switch drive so that the load rise time is limited to approximately $25(C_{LOAD})$. Thus, a $10\mu F$ capacitor would require a $250\mu s$ rise time, limiting the charging current to about 200mA.

COMPONENTS

Component selection can be very critical in switching power supply applications. This section discusses some of the guidelines for selecting the different components. The LTC1433 data sheet details more specific selection criteria for most of the external components surrounding the IC. Be sure to refer to the data sheet if changes to this demo circuit are anticipated.

Capacitors

The most common component uncertainty with switching power supplies involves capacitors. In this circuit (refer to Figure 1) C7 and C8 are all specially developed, low ESR, high ripple current tantalum capacitors specifically designed for use in switching power supplies. ESR or equivalent series resistance is the parasitic series resistance in the capacitor. Very often this resistance is the limiting element in reducing ripple at the output or input of the supply. Standard wet electrolytics may cause the feedback loop to be

unstable (this means your power supply becomes an oscillator). They may also cause poor transient response or have a limited operating life. Standard parts normally do not have an ESR specification at high frequencies (100kHz), so although you may find a part that works to your satisfaction in a prototype, **the same part may not work consistently in production**. Furthermore, surface mount versions of wet electrolytics are not space efficient, and they may have high ESR and limited lifetimes.

Normal tantalums are not recommended for use in these applications (especially the low cost ones), as they do not have the ability to take the large peak currents that are required for the application. Tantalums have a failure mechanism whereby they become a low value resistance or short. Wet electrolytics rarely short; they usually fail by going high impedance if overstressed. Very few tantalum manufacturers have the ability to make capacitors for power applications.

There are some tantalums, such as those used in this design, that are specifically designed for switching power supplies. They are much smaller than wet electrolytic capacitors and are surface mountable, but they do cost more.

One other choice that fits between wet electrolytics and tantalums is organic semiconductor type capacitors (OS-CON) that are specifically made for power supply applications. They have very low ESR and are 1/2 the size of equivalent wet electrolytics.

Inductor

To most engineers, inductors are the least familiar components in a switching power supply. This is unfortunate, because the most flexible component in the system is the inductor. The size, shape, efficiency, form factor and cost are variables that can be traded off against one another. The only fixed requirement of the inductor used with the LTC1433 is that it must be able to support the output DC current and still maintain its inductance value.

Although the inductor used in the demo board is from Sumida, there are a wide variety of inductors available from other manufacturers. A Dale LPT4545 series inductor can

OPERATION

be used for this demo board, as can Coilcraft's D03316 series and Coiltronic's CTX series. However, recharacterizing the circuit for efficiency is necessary if any of the alternate inductors are used in place of the one supplied.

There are many inductors that will work in this circuit. Each inductor design will have a different physical size, different loss characteristics and different stray field patterns. All of these items must be considered to optimize a design.

Because of the aforementioned variations in design and cost of the inductor, we suggest you contact some of the inductor manufacturers in Table 1 and discuss your needs with them. Very often a standard low cost solution that will meet your needs is on the shelf.

Schottky Diode

The catch diode carries load current during the off-time. The average diode current is therefore dependent on the P-channel switch duty cycle. At high input voltages the diode conducts most of the time. As V_{IN} approaches V_{OUT} , the diode conducts for only a small fraction of the time. The most stressful condition for the diode is when the output is short-circuited. Under this condition the diode must safely handle I_{PEAK} at close to 100% duty cycle. A fast switching diode must also be used to optimize efficiency. Schottky diodes are a good choice for low forward drop and fast switching times. Most LTC1433 circuits will be well served by a MBRM5819 or MBRS130LT3 Schottky diode.

Component Manufacturers

Besides those components that are use on the demonstration board, other components may also be used. Tables 1 and 2 are a partial list of the manufacturers whose components can be used for the switching regulators. Using components other than the ones on the demonstration board requires recharacterizing the circuit for efficiency.

Table 1. Inductor Manufacturers

MANUFACTURER	PART NUMBERS
Coilcraft 1102 Silver Lake Road Cary, Illinois 60013 (Phone) 847-639-6400 (Fax) 847-639-1469	D03316 Series
Coiltronics International 6000 Park of Commerce Blvd Boca Raton, FL 33487 (Phone) 407-241-7876 (Fax) 407-241-9339	Econo-Pac Octa-Pac
Dale Electronics Inc E. Highway 50 P.O Box 180 Yankton, SD 57078-0180 (Phone) 605-665-9301 (Fax) 605-665-1627	LPT4545
Sumida Electric Co Ltd. 5999 New Wilke Rd, Suite #110 Rolling Meadows, IL 60008 (Phone) 847-956-0666 (Fax) 847-956-0702	CLS62 Series CD 54 Series CDR74B Series

Table 2. Capacitor Manufacturers

MANUFACTURER	PART NUMBERS
AVX Corporation P.O Box 887 Myrtle Beach, SC 29578 (Phone) 803-448-9411 (Fax) 803-448-1943	TPS Series
Sanyo Video Components 2001 Sanyo Avenue San Diego, CA 92071 (Phone) 619-661-6322 (Fax) 619-661-1055	OS-CON Series
Sprague 678 Main Street Sanford, ME 04073 (Phone) 207-324-4140 (Fax) 207-324-7223	593D Series

DEMO MANUAL DC144

NO DESIGN SWITCHER

PCB LAYOUT AND FILM

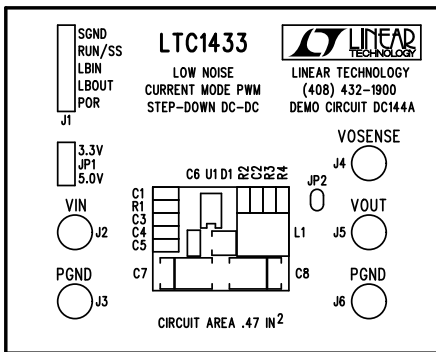

Component Side Silkscreen

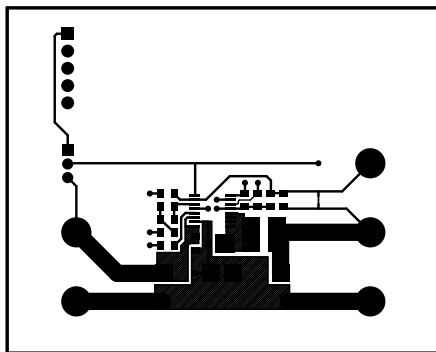

Component Side

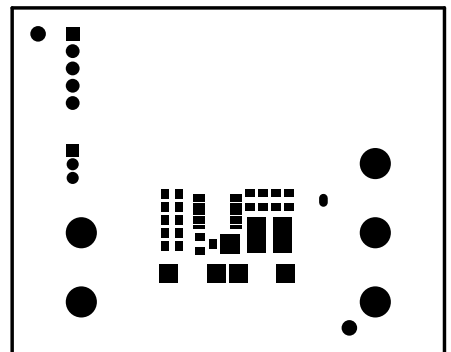

Component Side Solder Mask

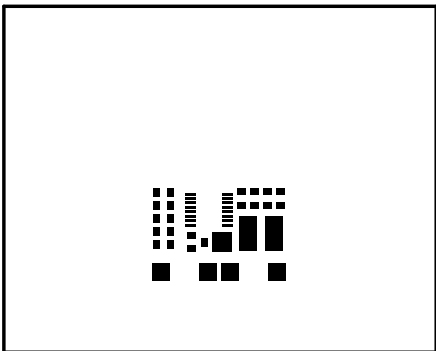

Pastemask

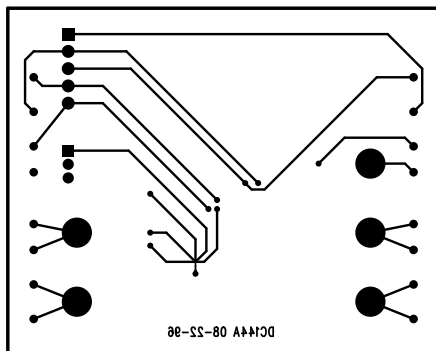

Solder Side

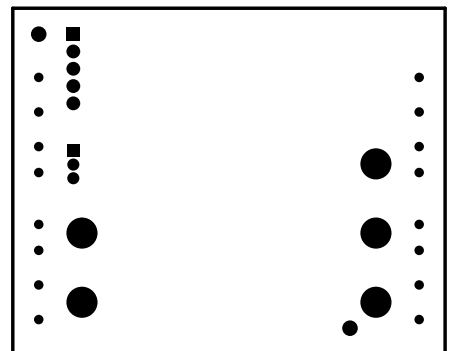

Solder Side Solder Mask

PC FAB DRAWING

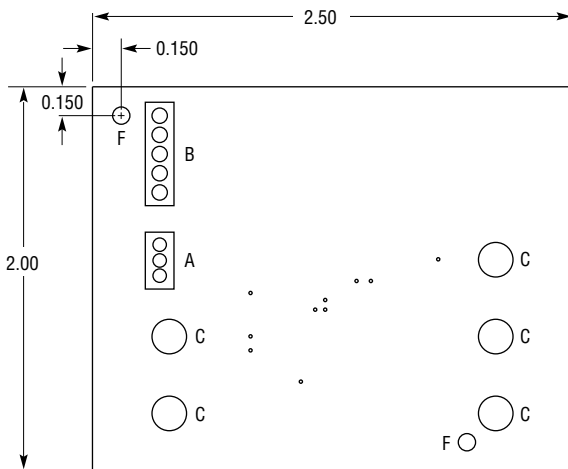

NOTES:

1. ALL DIMENSIONS ARE IN INCHES ± 0.003
2. FINISHED MATERIAL IS FR4, 0.062 THICK, 2 OZ COPPER, 2 LAYERS
3. FINISHED HOLE SIZES ARE 0.003/-0
PLATED HOLE WALL THICKNESS IS 0.0001 MINIMUM
4. SOLDER MASK BOTH SIDES USING GREEN SR1020 OR EQUIVALENT
6. SILKSCREEN WHITE NONCONDUCTIVE INK COMPONENT SIDE

SYMBOL	DIAMETER	NUMBER OF HOLES
NONE	0.015	10
A	0.031	3
B	0.040	5
C	0.095	5
F	0.070	2
TOTAL HOLES		25

DC144 FAB