

# DESIGN NOTES

## Efficient Processor Power System Needs No Heat Sink

Design Note 135

John Seago

New designs require more functionality in an ever decreasing package size. Compact, efficient high frequency power supplies are required and there is seldom room for a heat sink. Portable computers have some of the most demanding requirements. Powering the Pentium processor adds additional challenges for the power system designer.

### New IC Powers Portable Pentium Processor and Much More

The LTC<sup>®</sup>1435 is a current mode, constant frequency, synchronous step-down switching regulator that uses external N-channel MOSFETs for very high efficiency. With the wide input voltage range of 3.5V to 36V and low dropout (99% duty cycle) capability, the LTC1435 is a good choice for battery-powered circuits where the voltage of four NiCd cells can drop to 3.6V at the end of discharge. The ability to operate with 36V inputs allows application of a wide range of AC adapter voltages. The LTC1435 achieves battery-powered efficiencies of 90% to 95% and features Burst Mode<sup>®</sup> operation for longest battery life under light load conditions. For constant frequency at all load conditions, the Burst Mode operation can be defeated easily on the LTC1435. The Adaptive Power<sup>™</sup> mode, available on the LTC1436, provides constant frequency at light loads with greatly

improved efficiency. With a “silver box” power supply or other high current voltage source, the LTC1435 can easily provide an output current of 12A.

The LTC1435's current mode architecture and 1% voltage reference provide a tightly controlled output voltage with excellent load and line regulation and outstanding set-point accuracy. The switching frequency can be selected between 50kHz and 400kHz, so total circuit cost, efficiency, component size and transient response can be properly balanced. The LTC1435 also features both logic-level on/off control and output current soft start. When the controller is in the shutdown mode, voltage is removed from the load and quiescent input current drops to a mere 15 $\mu$ A. The LTC1435 is available in the popular 16-pin SO and SSOP packages.

### High Performance Pentium Processor Power

The 150MHz Pentium load current changes from 0.2A to 4.5A in about 15ns. The core voltage must be maintained at 3.5V  $\pm$  0.1V under all conditions.

The LTC1435 circuit shown in Figure 1 was used to power an Intel Power Validator to simulate the typical Pentium processor load transient of 0.2A to 4.5A. The

 LT, LTC, LTM, Linear Technology, the Linear logo and Burst Mode are registered trademarks and Adaptive Power is a trademark of Linear Technology Corporation. All other trademarks are the property of their respective owners.

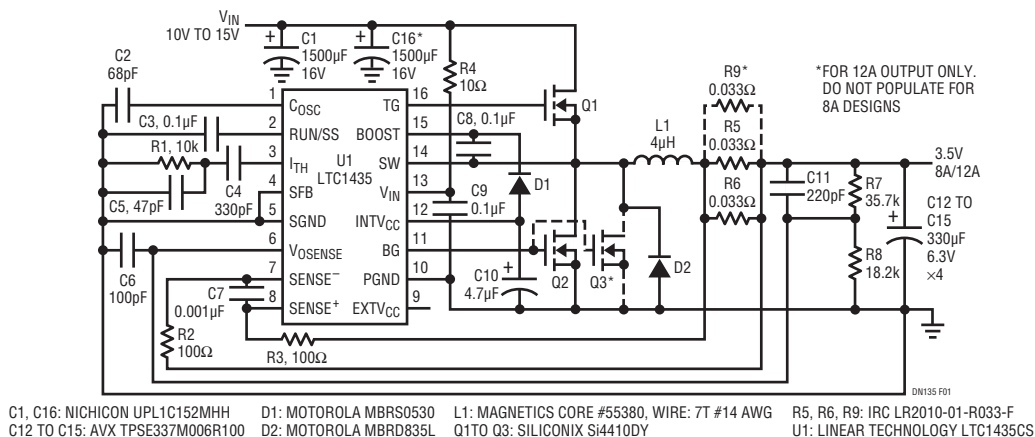

Figure 1. 12V to 3.5V Regulator for 8A or 12A Applications

transient waveform in Figure 2 shows a  $\pm 0.04V$  variation in output voltage with  $700\mu F$  of local decoupling capacitance at the Power Validator and the  $1300\mu F$  capacitance at the regulator output. The same base circuit was used to power both 8A and 12A static loads. By changing the value of R8, the output voltage can be set from 1.8V to 5V at a full 12A. Outputs of up to 9V are possible with some minor changes.

### Portable Pentium Processor Power

The portable Pentium processor requires a core voltage of  $2.9V \pm 0.165V$  and switches between 0.25A and 2.65A in about 30ns. This load was simulated by the Power Validator and powered by the circuit of Figure 3. Although this circuit works very well over the input voltage range of 5.5V to 28V, it will continue to provide portable Pentium processor core voltage down to a 3.5V input by adding C13 and C14. Figure 4 shows the

output voltage transient and load current waveforms with an input voltage of 3.5V. Figure 5 shows circuit efficiency over load and line conditions.

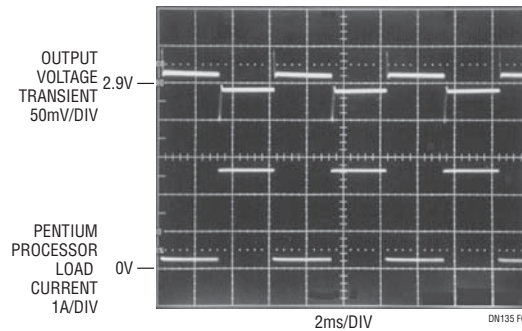

Figure 4. Portable Pentium Processor Load Transient Waveform

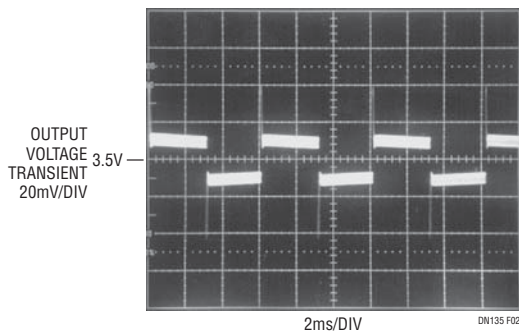

Figure 2. High Performance Pentium Processor Load Transient Waveform

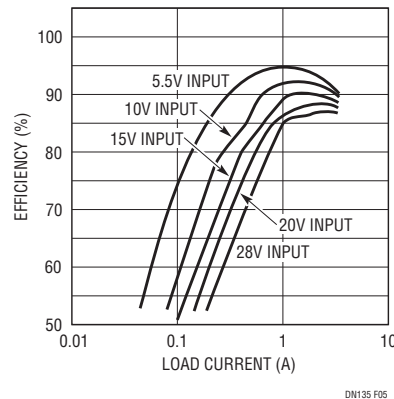

Figure 5. LTC1435 Efficiency Curves for Different Input Voltages

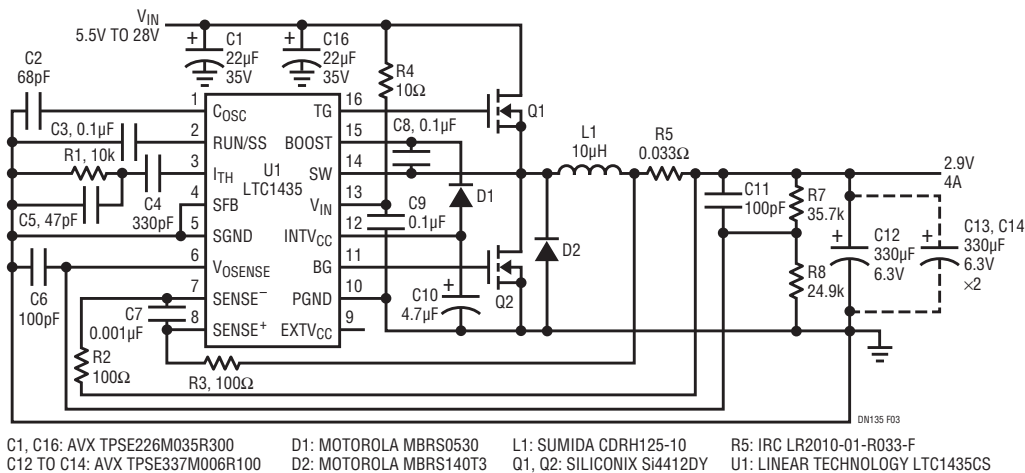

Figure 3. 2.9V Regulator for Portable Pentium Processor

Data Sheet Download

www.linear.com

For applications help,  
call (408) 432-1900

Linear Technology Corporation  
1630 McCarthy Blvd., Milpitas, CA 95035-7417  
(408) 432-1900 • FAX: (408) 434-0507 • www.linear.com

dn135f\_conv LT/GP 0896 155K • PRINTED IN THE USA

  
© LINEAR TECHNOLOGY CORPORATION 1996