

DESIGN NOTES

Optimized DC/DC Converter Loop Compensation Minimizes Number of Large Output Capacitors – Design Note 186

John Seago

There is a trade-off between the cost of a few extra passive components and the flexibility that external loop compensation provides. Internal loop compensation is fixed, so it uses fewer passive parts but it also limits the designer's choice of output capacitors. The output capacitor should be chosen to meet the load requirements, not the regulator requirements. The external loop compensation provided by the LTC[®]1435 family of parts allows the control loop to be optimized for the output capacitance required by the load.

External Loop Compensation Can Save Money

By changing two or three passive component values, the LTC1435 allows the loop to be compensated for the output capacitor that meets the load requirements. External loop compensation allows the designer to optimize both the buck inductor and output capacitor for each application.

Although some loads have stringent transient requirements, many do not. The function of the output capacitor is to smooth the output voltage ripple and to source or

sink output current until the regulator can respond to changes in load current. If the regulator can respond as quickly as the load current changes, very little output capacitance is required.

Figure 1 shows an LTC1435 configured for a 3.3V output with less than 50mV of output ripple and a 100mV transient response. The values for the primary loop-compensation components, C3 and R1, were selected by means of dynamic load testing, using the pulsed-load circuit shown in Figure 2. The load-pulsar resistor values were selected to switch the load current between 1.5A and 3A at a 60mA/μs rate, to simulate actual load conditions. Figure 3 shows the output voltage transient waveform.

Briefly, the values of C3, C4 and R1 determine the voltage gain and phase of the internal error amplifier at different frequencies. The value of C3 determines the low frequency gain, R1 determines the midband gain

LT, LTC, LTM, Linear Technology and the Linear logo are registered trademarks of Linear Technology Corporation. All other trademarks are the property of their respective owners.

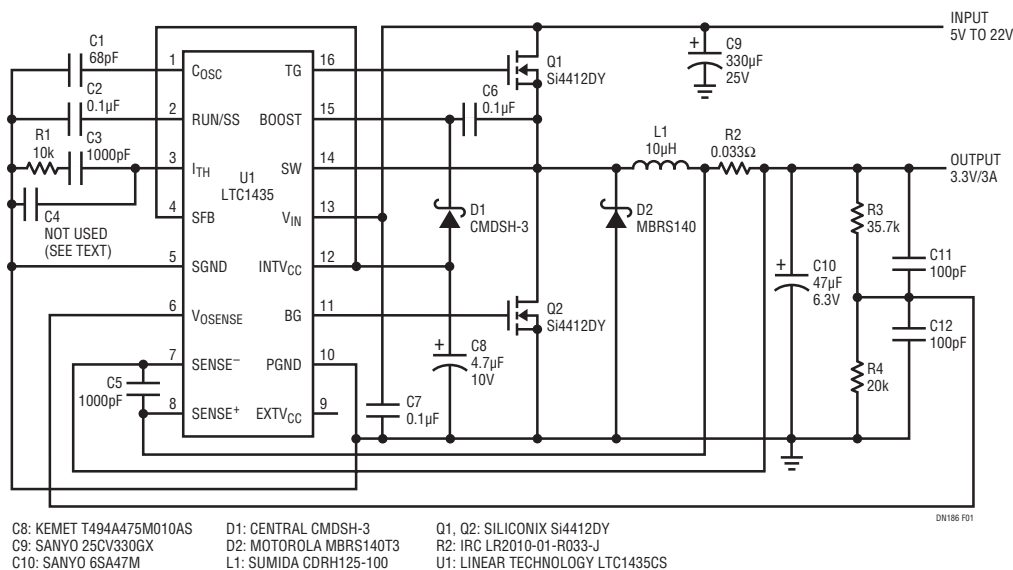

Figure 1. Low Output Capacitance Voltage Regulator

and C4 reduces gain at high frequencies. Generally, the values of C3 and C4 should be as small as possible and the value of R1 should be as large as possible.

Loop Compensation Using a Dynamic Load

Although many engineers consider control-loop theory difficult, most of the work is already done when optimizing a circuit for a particular load. The component values shown in the data sheet will provide stable operation under all static load conditions and most dynamic load conditions. The process of optimizing component values is not difficult. Using a dynamic load, or the pulsed-load circuit shown in Figure 2, select the appropriate output capacitor and adjust the values of C3, C4 and R1 in Figure 1 to minimize the overshoot and ringing on the output voltage waveform. Now, verify that the output voltage transient waveform is correct over the entire input voltage range.

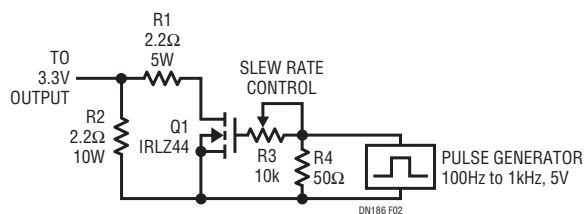

Figure 2. Pulsed-Load Circuit

It is also important to verify that the control loop is stable over the required operating temperature range. It is common to use a heat gun and freeze spray to test temperature extremes but it is important to monitor the actual temperature to avoid overtesting the circuit. It is best to use a temperature-controlled chamber for all temperature testing.

Testing loop stability over temperature is even more important when using regulators with fixed compensation. It may be necessary to add even more output capacitance to ensure stable operation over temperature.

Most labs don't have a dynamic load for power supply testing. The circuit in Figure 2 shows an inexpensive way to test load-transient response. The value of R2 was selected to draw the nominal, pretransient load current, whereas the value of R1 was selected for the required load-current step. Resistor R3 controls the slope of the load current step to better simulate actual load conditions.

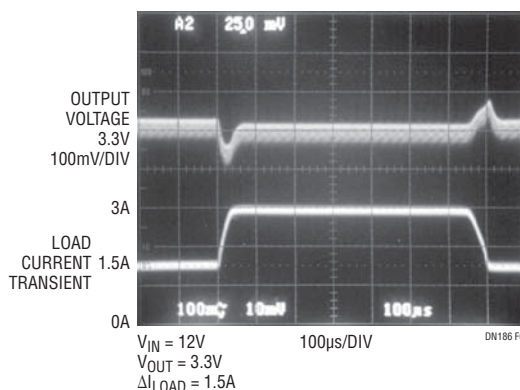

Figure 3. Transient Waveforms

The advantage of adjustable loop compensation is simple: optimizing loop compensation components allows the lowest cost output capacitor to be used for a given load requirement. Adjustable loop compensation is available on all of the LTC1435 family of parts. As shown in Table 1, both single and dual versions are available with a variety of additional features.

Table 1. LTC1435 Related Parts

PART NUMBER	DESCRIPTION	COMMENTS
LTC1436/LTC1436-PLL/ LTC1437	High Efficiency, Low Noise, Synchronous Step-Down Switching Regulator Controllers	Full-Featured Single Controllers
LTC1438	Dual Synchronous Controller with Power-On Reset and an Extra Comparator	Shutdown Current <30μA
LTC1439	Dual Synchronous Controller with Power-On Reset, Extra Linear Controller, Adaptive Power, Synchronization, Auxiliary Regulator and an Extra Uncommitted Comparator	Shutdown Current <30μA
LTC1538-AUX	Dual Synchronous Controller with AUX Regulator	5V Standby in Shutdown
LTC1539	Dual Synchronous Controller with the Same Features as the LTC1439	5V Standby in Shutdown

Data Sheet Download

www.linear.com

For applications help,
call (408) 432-1900

Linear Technology Corporation
1630 McCarthy Blvd., Milpitas, CA 95035-7417
(408) 432-1900 • FAX: (408) 434-0507 • www.linear.com

dn186f_conv LT/TP 0898 370K • PRINTED IN THE USA

© LINEAR TECHNOLOGY CORPORATION 1998