

DESIGN NOTES

High Efficiency, Monolithic Synchronous Step-Down Regulator Works with Single or Dual Li-Ion Batteries

Design Note 201

Jaime Tseng

Li-Ion batteries, with their high energy density, are becoming the chemistry of choice for designers of many handheld products. In response to this growing trend, the LTC[®]1627 incorporates features optimized for such chemistry. For instance, the LTC1627 integrates a precision undervoltage lockout circuit that shuts itself down when the supply voltage dips below 2.5V, drawing only 6 μ A of quiescent current. This prevents damaging a Li-Ion battery when it is nearing its end of charge. The operating supply range of the LTC1627 is from 2.65V to 8.5V; this accommodates one or two Li-Ion batteries and 3- to 6-cell NiCd and NiMH battery packs.

The LTC1627 is a current mode buck regulator using a fixed frequency architecture. It incorporates power-saving Burst Mode[®] operation and allows 100% duty cycle. The current mode architecture gives the LTC1627 excellent load and line regulation. Burst Mode operation provides high efficiency at low load currents. 100% duty cycle provides low dropout operation that extends operating time in battery-operated systems. The operating frequency is internally set at 350kHz, allowing the use

of small surface mount inductors. For switching noise sensitive applications the LTC1627 can be externally synchronized at up to 525kHz by applying a clock signal of at least 1.5V_{P-P} to the SYNC/FCB pin.

Figure 1 shows a typical LTC1627 application circuit suitable for a single or dual Li-Ion battery input. Note that the Schottky diode normally seen on the SW pin is absent in Figure 1—the LTC1627 has no need for it, saving cost. Figure 2 shows the efficiency curves for three different input voltages. The efficiency with a 3.6V input exceeds 90% over a load range from 10mA to 600mA, making the LTC1627 attractive for all battery-operated products and efficiency sensitive applications.

Single Li-Ion Applications

In single Li-Ion battery applications requiring a maximum output load current of 500mA, the top P-channel MOSFET's gate can be driven below ground to reduce its $R_{DS(ON)}$. This reduces the I^2R loss that dominates the efficiency loss in low V_{IN} applications. As V_{IN} drops,

LT, LTC, LTM, Linear Technology, the Linear logo and Burst Mode are registered trademarks of Linear Technology Corporation. All other trademarks are the property of their respective owners.

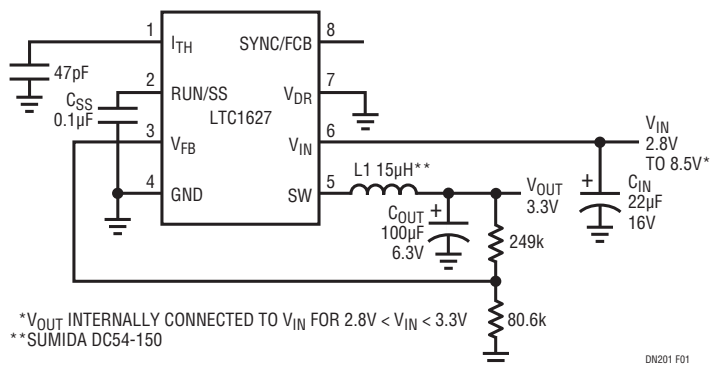

Figure 1. High Efficiency Step-Down Converter

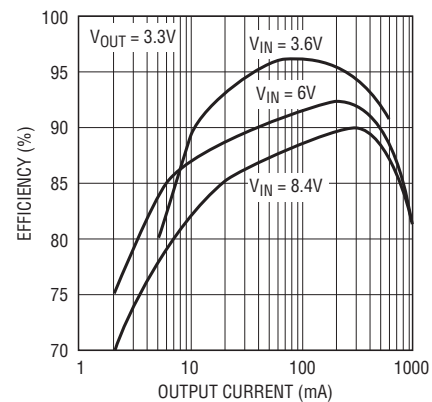

Figure 2. Efficiency vs Output Load Current

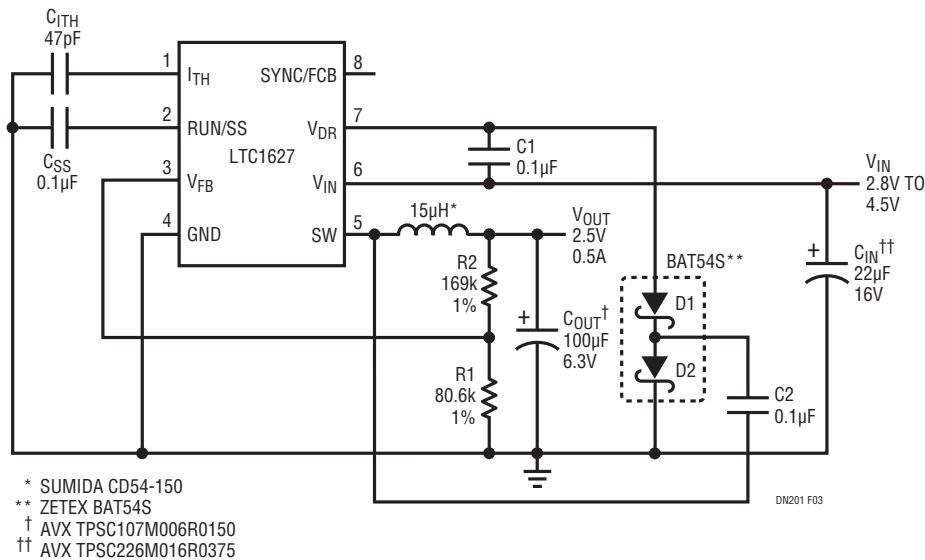

Figure 3. Single Lithium-Ion to 2.5V/0.5A Regulator

the duty cycle of the converter increases until, in the extreme case, it reaches dropout, where the P-channel MOSFET is on continuously. Figure 3 shows an application circuit suitable for a single Li-Ion cell that can deliver a 500mA load current down to $V_{IN} = 3V$. The top P-channel MOSFET driver makes use of a floating pin, V_{DR} , to allow biasing below ground. A simple charge pump bootstrapped to the SW pin realizes a negative voltage at the V_{DR} pin, as shown. Using the charge pump at $V_{IN} \geq 4.5V$ is not recommended, as this may cause $(V_{IN} - V_{DR})$ to exceed its absolute maximum value of 10V. If V_{IN} decreases to a voltage close to V_{OUT} , the loop may enter dropout and attempt to turn on the P-channel MOSFET continuously. A dropout detector counts the number of oscillator cycles that the P-channel MOSFET remains on, and periodically forces a brief off period to allow C1 to recharge. (100% duty cycle is allowed when V_{DR} is grounded as shown in Figure 1.)

Auxiliary Winding Control Using SYNC/FCB Pin

The SYNC/FCB pin controls the operation of the internal synchronous MOSFET by inhibiting Burst Mode operation and forcing continuous mode operation. When this pin drops below its ground referenced 0.8V threshold, continuous mode operation is forced. In continuous mode operation, the internal main and synchronous MOSFETs are switched continuously, regardless of the load on the main output. Synchronous switching removes the normal limitation that power must be drawn

from the inductor primary winding in order to extract power from auxiliary windings. Synchronous operation allows power to be drawn from the auxiliary windings regardless of the primary output load.

The secondary output voltage is set by the turns ratio of the transformer in conjunction with a pair of external resistors returned to the SYNC/FCB pin, as shown in Figure 4. The secondary voltage V_{SEC} in Figure 4 is given by:

$$V_{SEC} \cong (N+1)V_{OUT} - V_{DIODE} > 0.8V \left(1 + \frac{R4}{R3}\right)$$

where N is the turns ratio of the transformer, V_{OUT} is the main output voltage sensed by V_{FB} and V_{DIODE} is the voltage drop across the Schottky diode.

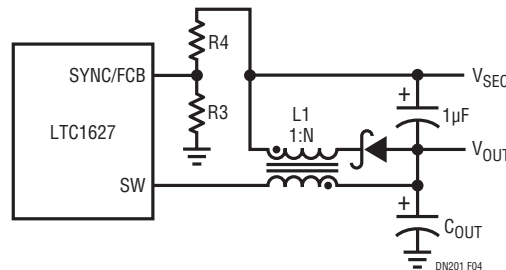

Figure 4. Secondary Output Loop Connection

Data Sheet Download

www.linear.com

For applications help,
 call (408) 432-1900