



# DESIGN NOTES

## Low Cost, High Efficiency 30A Low Profile PolyPhase Converter

Design Note 211

Wei Chen and Craig Varga

The growing need for very high current logic supplies often exceeds the capability of a single buck (step-down) converter. The solution is a PolyPhase™ converter where two or more buck sections work in parallel to deliver a single high current output.

### Overview of the LTC1629

The LTC®1629 is a current mode, PolyPhase controller that interleaves the clock signals of two synchronous buck stages, reducing input and output ripple currents without increasing the switching frequency. Because of the output ripple current cancellation, lower value inductors can be used, resulting in a faster load transient response. Lower current rating and decreased inductance also allow the use of smaller sized, low profile, surface mount inductors. The integrated high current MOSFET drivers are capable of driving low  $R_{DS(ON)}$  MOSFETs efficiently. This LTC1629-based design achieves 90% efficiency with 12V input and 3.3V output voltage at 30A.

Each LTC1629-based regulator consists of two synchronous buck stages. Current mode control ensures current sharing allowing two or more such regulators to be paralleled directly. Moreover, the LTC1629 integrates proprietary phase locked loop-based clock phasing circuitry, enabling 2-, 3-, 4-, 6- or 12-phase operation with a simple phase selection signal (high, low or open). The LTC1629 includes an internal instrumentation amplifier, enabling true remote sensing. This is particularly useful for maintaining tight regulation actually at the point of load in high current applications.

The peak current mode control provides current sharing among the paralleled power stages. When multiple LTC1629-based regulators are used in parallel, the differential amplifier of the master LTC1629 senses the output voltage and feeds a control voltage to the other slave LTC1629s for voltage regulation. The  $g_m$  error amplifier inside each LTC1629 allows direct paralleling of the  $I_{TH}$  pins (error amplifier outputs). The paralleled regulators share the same error voltage and source equal currents because

LTC and LT are registered trademarks of Linear Technology Corporation. PolyPhase is a trademark of Linear Technology Corporation.

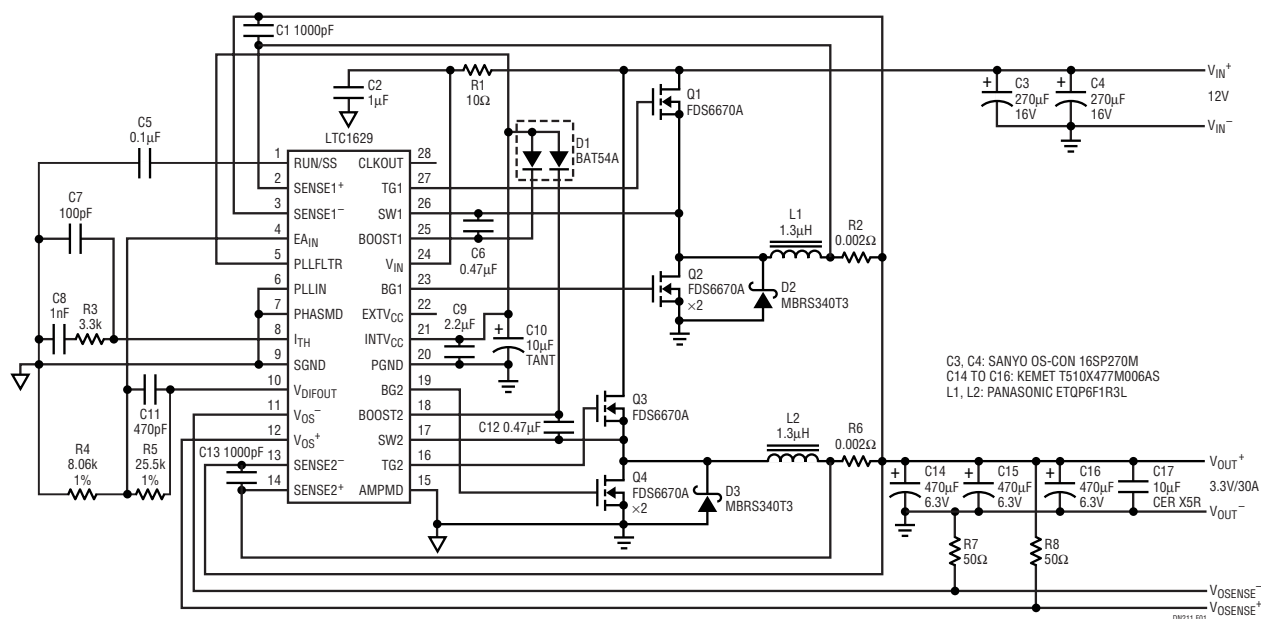

Figure 1. Schematic Diagram of a 30A Power Supply Using LTC1629

the load current in a current mode regulator is proportional to the error voltage.

### Design Example: 30A 2-Phase Power Supply

Figure 1 shows the schematic diagram of a 12V input, 3.3V/30A output PolyPhase power supply. Two synchronous buck output stages and one LTC1629 are employed to provide the 30A output current. Different output voltages may be achieved by changing R4 in the schematic diagram. The switching frequency is selected to be 300kHz. This results in the use of a 1.3 $\mu$ H/15A inductor for each buck circuit.

Table 1 compares the input and output ripple currents and input and output capacitors for single phase and 2-phase configurations. The single phase circuit employs only one buck converter. Compared to the single phase converter, the dual phase converter reduces the input ripple current by more than 45% and the output ripple current by more than 67%. The resulting reductions in the size and cost of capacitors are significant as shown in Table 1.

**Table 1. Comparisons of Input and Output Ripple Currents for Single Phase and Dual Phase Configurations (L = 1.3 $\mu$ H, f<sub>S</sub> = 300kHz)**

Phases	Input Ripple Current (A <sub>RMS</sub> )	Output Ripple Current (A <sub>P-P</sub> )	No. of Input Capacitors: OS-CON 16P270M	No. of Output Capacitors for the Same Output Ripple Voltage: Kemet T510X477M006AS
1	11.7	12.7 <sup>1</sup>	4	9
2	6.4	4.2	2	3

<sup>1</sup>Assume that the single phase circuit uses two 1.3 $\mu$ H/15A inductors in parallel to provide 30A output.

Figure 2 shows the measured output ripple voltage at full load. The output ripple voltage is less than 40mV<sub>P-P</sub> and the ripple frequency is twice the switching frequency.

Figure 3 shows the measured efficiency as a function of load current. For most of the load range, the efficiency exceeds 90%. An overall efficiency of close to 90% was measured with a 3.3V/30A output. Note that only six SO-8 MOSFETs are used in the complete power supply.

### Conclusion

PolyPhase converters using the LTC1629 reduce the size and cost of the capacitors and inductors due to input and output ripple current cancellation. Lower output ripple voltage and smaller inductors help improve the circuit's

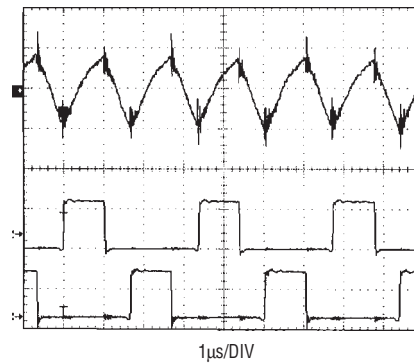

**Figure 2. Output Ripple Voltage Waveforms. Top Trace: Output Ripple Voltage, 20mV<sub>AC</sub>/DIV. Middle Trace: V<sub>DS</sub> on Q2, 10V/Div. Bottom Trace: V<sub>DS</sub> on Q4, 10V/DIV**

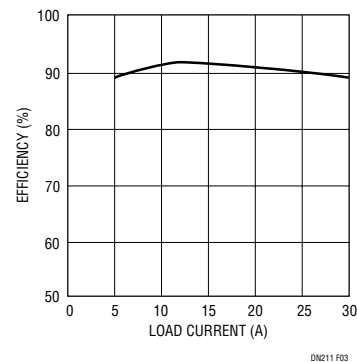

**Figure 3. Measured Efficiency vs Load Current**

dynamic performance during load transients. The LTC1629 helps minimize the external component count and simplifies the complete power supply design by integrating two PWM current mode controllers, true remote sensing, selectable phasing control, inherent current sharing capability, high current MOSFET drivers plus protection features (such as overvoltage protection, optional overcurrent latch-off and foldback current limiting) into one IC. The resulting manufacturing simplicity helps improve power supply reliability. High current MOSFET drivers allow the use of low R<sub>DS(ON)</sub> MOSFETs to minimize the conduction losses for high current applications. Lower current ratings on the individual inductors and MOSFETs also make it possible to use low profile, surface mount components. Therefore, an LTC1629-based PolyPhase high current converter can achieve high efficiency, small size and low profile simultaneously. The savings on the input and output capacitors, inductors and heat sinks minimizes the overall cost and size of the complete power supply.

### Data Sheet Download

<http://www.linear-tech.com/go/dnLTC1629>

For literature on our Controllers, call **1-800-4-LINEAR**. For applications help, call (408) 432-1900, Ext. 2593