

A POWER SUPPLY, JUST LIKE ANY OTHER ELECTRONIC CIRCUIT, CAN FAIL. OVERVOLTAGE PROTECTION REQUIRES FEW PARTS AND IS EFFECTIVE AND RELATIVELY INEXPENSIVE INSURANCE FOR COSTLY ELECTRONICS SYSTEMS.

Overvoltage-protection circuit saves the day

POWER-SUPPLY FAILURE TAKES on significant importance in high-end computer, telecom, medical, and industrial applications, in which uninterrupted power is paramount. In these systems, diode-OR-ed redundant power supplies fulfill the uninterruptible requirement (Figure 1). However, the failed power supply must also disengage from the circuit before its overvoltage condition affects sensitive circuitry.

NONISOLATED DC/DC CONVERTER

The easiest way to protect the load from overvoltage is to crowbar—that is, short out—the power source that caused the overvoltage condition. To ensure reliable protection, the overvoltage-protection circuit must be independent from the rest of the system’s circuits; it must have its own voltage reference and independent power source. The crowbar circuit usually requires a short trigger

pulse. Power can come from the voltage rail being protected.

A simple, small, and cost-effective circuit uses an LTC1696, IC₁, and a few external components to provide stand-alone power-supply monitoring and overvoltage protection (Figure 2). This circuit has an important advantage over other methods because it provides a way to protect the load from a short circuit in the MOSFET, Q₁.

The crowbar method is effective in nonisolated circuits, but it is unsuitable for isolated circuits where high output currents can exceed 100A. In a typical forward converter for isolated applications, a transformer, T₁, required for input-to-output isolation, adds inherent protection for the load (Figure

Figure 1

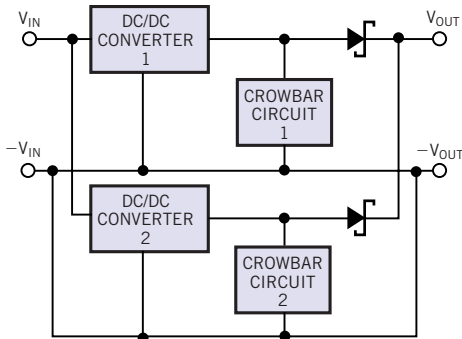

Power subsystems in high-end equipment contain redundant supplies.

Figure 2

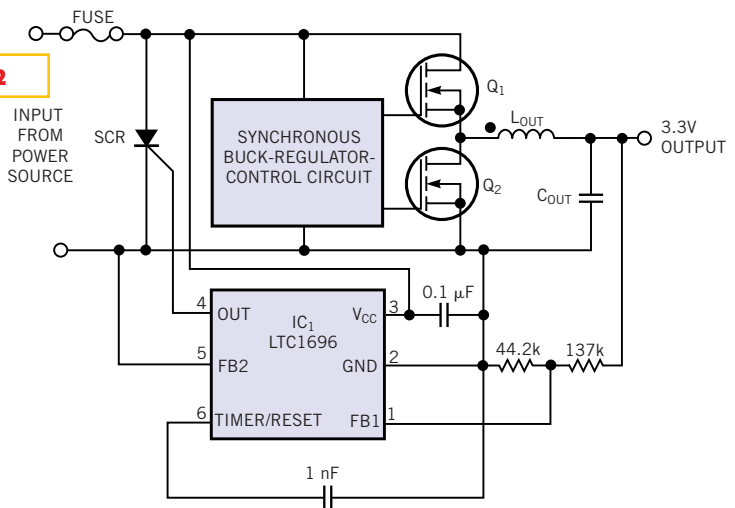

A nonisolated dc/dc converter implements crowbar-based overvoltage protection.

Figure 3

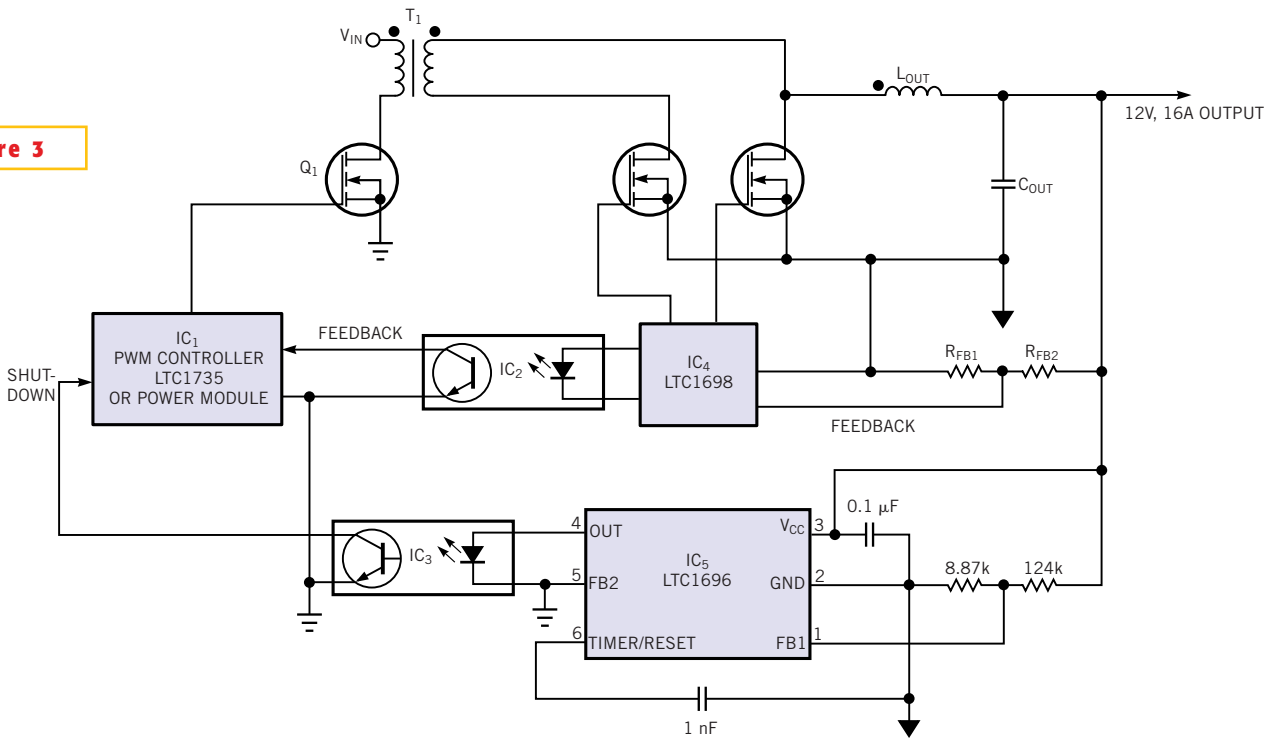

An overvoltage-protected isolated dc/dc converter is particularly appropriate in high-output-current applications.

3). If the primary MOSFET, Q_1 , fails short, the output of this converter collapses without damaging the load.

Nevertheless, isolated applications are susceptible to another type of failure. If any of the components in the feedback loop fails and opens the loop, the output of the power supply rises to compensate, resulting in an overvoltage condition.

Even some component-short-circuit conditions can result in an open feedback loop. For example, if an optocoupler emitter diode shorts out, the feedback loop becomes open; no feedback comes from the converter output to the input controller.

To prevent this potential failure mechanism, you must stop the MOSFET from switching so that the output voltage col-

lapses. The first approach to accomplishing this goal uses the logic-level shutdown function of the primary-side control circuit. The LTC1696, for example, generates a signal to pull the shutdown pin low thus causing the power converter to stop running and the output voltage to collapse.

The second approach is to remove the

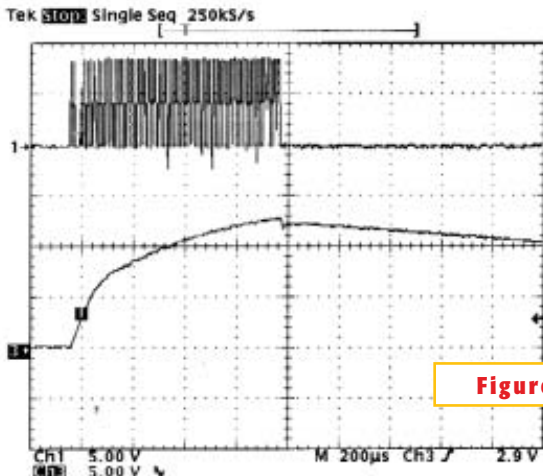

Figure 4

An overvoltage plot shows the MOSFET-gate-drive pulses (top) and output voltage (bottom).

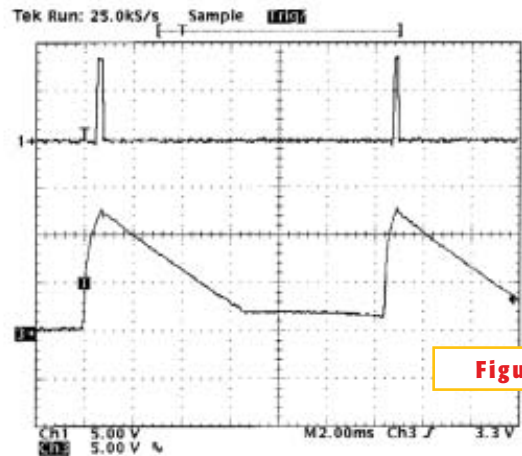

Figure 5

A large time-scale plot indicates that the converter attempts to restart every 12 msec. Individual pulses within the gate-drive-pulse envelope are not visible at the 2-msec/division display resolution.

power that generates the pulse-width train that drives Q_1 . Typically, the voltage to drive the primary-side logic circuits, IC_1 , is 5 to 15V. In this case, the output from the optocoupler, IC_3 , can disconnect the supply voltage of PWM controller, IC_1 .

A setup with an isolated, synchronous, high-efficiency converter tests the overvoltage-protection circuit. The converter employs an LTC1735, IC_1 , primary-side controller and an LTC1698, IC_4 , secondary-side, synchronous MOSFET driver-optocoupler feedback controller. The test converter generates 12V at 16A with high efficiency; IC_4 helps to bring the peak efficiency to 92%. The LTC1698, R_{FB1} and R_{FB2} , senses the output voltage and compares it with an internal precision-voltage reference. The error-amplifier signal of the LTC1698 drives the optocoupler, IC_2 , which provides output voltage feedback to the primary-side PWM controller, IC_1 .

The circuit reacts when removal of the LTC1698 feedback resistor, R_{FB2} , forces an

**WHEN THE CONVERTER
TRIES TO RESTART EVERY
12 MSEC, THE TOP TRACE
SHOWS THE ENVELOPE
OF THE BURST OF GATE
PULSES.**

overvoltage condition (Figure 4). At start-up, the dc/dc converter commences its soft-start power-up sequence by ramping the output to the nominal operating voltage of 12V (bottom trace). Because removing the resistor alters the voltage divider in the feedback loop, however, the output voltage rises past 12V. As soon as the output voltage reaches the overvoltage-protection setpoint (13V in this case), the LTC1696 turns on the optocoupler, IC_3 . The output signal of the optocoupler shuts down the pri-

mary-side controller LTC1735, IC_1 .

A larger time scale shows the response when the converter tries to restart every 12 msec (Figure 5). The top trace shows the envelope of the burst of gate pulses, driving Q_1 . If this restarting behavior is undesirable, you can implement a latch-off on either the primary or the secondary side via the built-in latch-off function of LTC1696. In this case, though, the LTC1696's power must come from an independent source. □

AUTHOR'S BIOGRAPHY

Goran Perica is an applications engineer at Linear Technology Corp (Milpitas, CA, www.linear.com), where he has worked for five years. In his current position, he designs power-conversion circuits for the telecommunication, computer, and industrial markets. He has a master's degree in electrical engineering from the University of Ljubljana, Slovenia. His spare-time pursuits include enjoying music and hiking with his wife and two ex-racing greyhounds.