

# DESIGN NOTES

## Power Supply Tracker Can Also Margin Supplies – Design Note 372

Dan Eddleman

Power supply margining is a technique commonly used to test circuit boards in production. By adjusting power supply output voltages, electrical components are tested at the upper and lower supply voltage limits specified for a design. The LTC<sup>®</sup>2923 power supply tracking controller can be used to margin supplies in addition to its usual task of tracking multiple power supplies.

The LTC2923 uses the simple tracking cell shown in Figure 1 to control the ramp-up and ramp-down behavior of multiple supplies. This cell serves the TRACK input to 0.8V and mirrors the current supplied by that pin at the FB output pin. The FB pin connects to the feedback node of the slave power supply. Normally, a resistive divider connects the master signal to the TRACK pin. By selecting the appropriate resistor values,  $R_{TA}$  and  $R_{TB}$ , the relationship of the slave power supply is configured relative to the master signal.

The supply margining application uses an LTC2923 tracking cell to margin a supply high and low under the control of a three-state I/O pin.

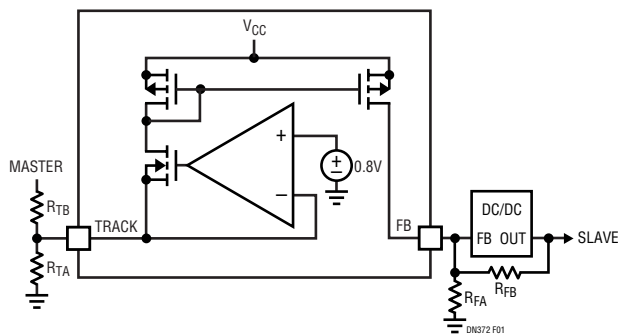

Figure 1. Simplified Tracking Cell

In the circuit shown in Figure 2, the supply is margined to its high, low and nominal output voltages by driving the I/O pin to its high, low and high impedance states respectively. This example shows calculated resistor values rather than standard resistor values for ease of

illustration. If the feedback voltage,  $V_{FB}$ , of the power supply is 0.8V, solve for the value of  $R_{FM1}$  that must be added in parallel with  $R_{F1}$  of the existing design to produce the desired high margin output.

In Figure 2, the feedback resistors  $R_{F2}$  and  $R_{F1}$  produce an output voltage of 2.5V. To margin 10% high to 2.75V requires a 54.4k resistor,  $R_{FM1}$ , in parallel with  $R_{F1}$ . Now connect a resistor,  $R_{TM1}$ , whose value is equal to  $R_{FM1}$  between the TRACK pin and ground. If the output will be margined low by the same voltage that it was margined high, then connect another resistor,  $R_{TM2}$ , equal to  $R_{FM1}$ , between the TRACK pin and the three-state I/O pin.

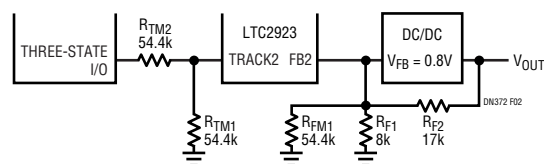
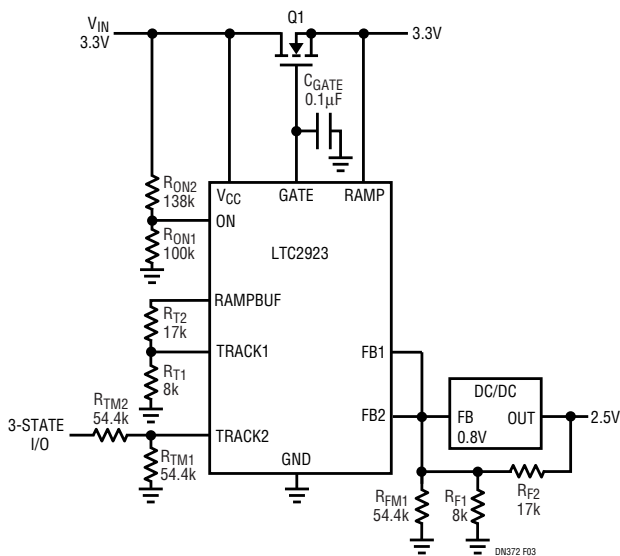

Figure 2. The LTC2923 Margins the Output of a 2.5V Supply 10% High or Low Under the Control of a Three-State I/O

In the circuit shown in Figure 3, an LTC2923 ramps up a 3.3V supply through a series FET, tracks a 2.5V supply to that 3.3V supply, and margins the 2.5V supply up and down by 10%. The first tracking cell connected to pins TRACK1 and FB1 causes the 2.5V supply to track this 3.3V supply during power up and power down as shown in Figure 4. The tracking cell connected to TRACK2 and FB2 is used to margin the 2.5V supply up and down by 10%.

The operation of the circuit in Figure 3 is simple. To margin high, the I/O pin is pulled above 1.6V. This pulls the TRACK2 pin above 0.8V so that no current is sourced into the feedback node of the power supply. The supply then defaults to its margined high output of 2.75V. For a nominal output, the I/O is high impedance. Now, no

LT, LTC and LT are registered trademarks of Linear Technology Corporation. All other trademarks are the property of their respective owners.



**Figure 3. The 2.5V Supply Tracks the 3.3V Supply and Can be Margined High or Low by 10% Under Control of a Three-State I/O**

current flows through  $R_{TM2}$  but  $14.7\mu\text{A}$  flows through  $R_{TM1}$  and is mirrored at the feedback node of the power supply. This forces the output voltage down by  $250\text{mV}$  to  $2.50\text{V}$ . For a margined low output, the I/O pin is pulled to ground. Now,  $14.7\mu\text{A}$  flows through  $R_{TM2}$  in addition to the  $14.7\mu\text{A}$  flowing through  $R_{TM1}$ . This current is mirrored at the power supply feedback node, and drives the output down by an extra  $250\text{mV}$  from nominal.

Note that the ability to configure a current driven into the feedback node with  $R_{TM1}$  often allows the nominal output voltage to be closer to the ideal value than is possible with a single pair of standard value resistors,  $R_{F1}$  and  $R_{F2}$ , in the power supply feedback network.

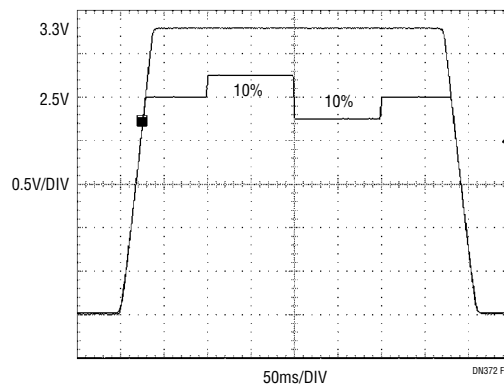

**Figure 4. Output of Circuit in Figure 3. The 2.5V Supply Tracks the 3.3V Supply and is Margined High and Low by 10%**

If the desired high and low voltage margins,  $\Delta V_{HIGH}$  and  $\Delta V_{LOW}$ , are not equal simply adjust  $R_{TM2}$ . In this case, choose  $R_{FM1}$  as above to configure the high margin, and set  $R_{TM1} = R_{FM1}$ . Scale the voltage step  $\Delta V_{LOW}$  relative to the voltage step  $\Delta V_{HIGH}$  by choosing  $R_{TM2}$  by  $R_{TM1}/R_{TM2} = \Delta V_{LOW}/\Delta V_{HIGH}$ . For example, to change the margins in the above example to 10% high and 20% low, leave  $R_{FM1}$  and  $R_{TM1}$  unchanged at  $54.4\text{k}$ , but reduce  $R_{TM2}$  is to  $27.2\text{k}$ .

If the feedback voltage,  $V_{FB}$ , of the power supply is not  $0.8\text{V}$  then the values of  $R_{TM1}$  and  $R_{TM2}$  are scaled by  $0.8\text{V}/V_{FB}$ . If the feedback voltage in the above example were  $1.23\text{V}$ , then  $R_{TM1}$  and  $R_{TM2}$  would be scaled so that  $R_{TM1} = R_{TM2} = R_{FM1} \cdot 0.8\text{V}/1.23\text{V} = 35.4\text{k}$ .

### Conclusion

The LTC2923's primary application is tracking power supplies, but its versatile architecture is suited to other functions as well. The application described here allows a three-state I/O to control supply margining using a few resistors and an LTC2923 tracking cell.

### Data Sheet Download

<http://www.linear.com>

For applications help,  
call (408) 432-1900, Ext. 2452