

# DESIGN NOTES

## Pushbutton On/Off Controller with Failsafe Voltage Monitoring

Design Note 427

Victor Fleury

### Introduction

Have you had the exasperating experience of a laptop or PDA defiantly not responding to your commands? You frantically press key after key, but to no avail. As hope turns to anger (but just before you throw the company's laptop through the window) you slam your finger against the on/off power button. Ten seconds later, your laptop finally surrenders and the screen goes black in a high pitched whimper.

The unresponsive pushbutton was likely the result of an unresponsive  $\mu\text{P}$  or system logic—as evidenced by the crash. By pressing and holding the on/off pushbutton, the LTC2953 provides the user with the ability to force system power off, even under fault conditions. This long pushbutton command works independently of system logic and automatically shuts off power after the adjustable timer expires. The length of time the pushbutton must be held low in order to force a power down is adjustable with an external capacitor on the PDT pin.

### Pushbutton Challenges

The ON/OFF pushbutton of electronic devices presents the system designer with a unique set of challenges. The circuits that monitor the pushbutton translate the chattering pushbutton signal into a clean voltage step that

enables a DC/DC converter or turns on a power switch. These circuits communicate with system logic to make sure that power turns on and turns off in an orderly manner. Additionally, failsafe features should disable system power if there is a problem with either the input or output power supply. The pushbutton monitor must also be rugged: absorb high levels of electrostatic discharge, tolerate voltage transients below ground and operate at high voltage levels.

The LTC2953 pushbutton on/off controller with voltage monitoring addresses all of these issues by providing a complete solution for interfacing to the on/off pushbutton of electronic devices. This tiny IC integrates the timing circuitry needed to clean up the pushbutton chatter and provides a simple communication protocol for orderly system power turn on and turn off. The LTC2953 includes a deglitched lockout comparator that prevents the system from drawing power from a dead battery or low supply. The device also provides a single adjustable supply reset monitor with 200ms delay.

The LTC2953's wide input voltage range (2.7V to 27V) is designed to operate from single-cell to multicell battery stacks, thus eliminating the need for a high voltage

LT, LTC and LTM are registered trademarks of Linear Technology Corporation. All other trademarks are the property of their respective owners.

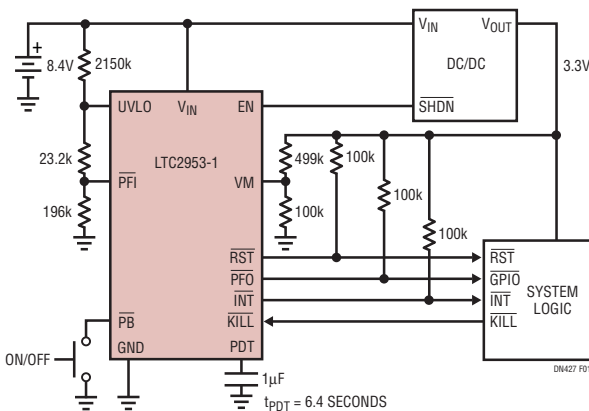

Figure 1. Typical Application

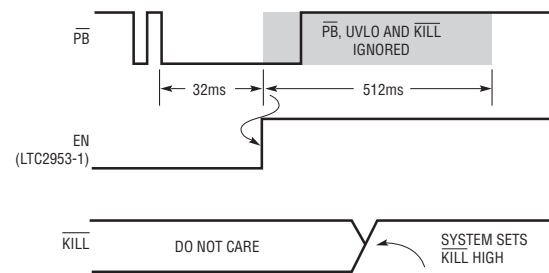

Figure 2. Orderly Power On

LDO. The part's feature set allows the system designer to turn off power to all circuits except the LTC2953, whose low quiescent current (14 $\mu$ A typical) extends battery life. The device is available in a space saving 12-lead 3mm  $\times$  3mm DFN package.

### Orderly Power On

The rugged pushbutton input of the LTC2953 connects directly to the electronic device's noisy, chattering mechanical on/off switch. To turn on system power, the LTC2953 asserts the enable output 32ms after detecting the end of pushbutton chatter. Once power has been enabled, the system must set the  $\overline{\text{KILL}}$  input high within 512ms. This 512ms timeout period is a failsafe feature that prevents the user from turning on the electronic device when there is a faulty DC/DC converter or an unresponsive microprocessor. The LTC2953 turns off power if  $\overline{\text{KILL}}$  is not set high during this time window. See Figure 1's application circuit and Figure 2's timing diagram.

### Orderly Power Off: Short Interrupt Pulse

Under normal conditions, an electronic device is turned off by pulsing the on/off power switch. To turn off system power, the LTC2953 asserts the interrupt output 32ms after detecting the end of pushbutton chatter. Upon noticing this interrupt signal, system logic performs power down and housekeeping tasks and asserts  $\overline{\text{KILL}}$  low when done. The LTC2953 subsequently releases the enable output, thus turning off system power (see Figure 3's timing diagram).

### Failsafe Features

The LTC2953 provides 3 comparators for voltage monitoring: UVLO, Power Fail and Reset. The UVLO comparator

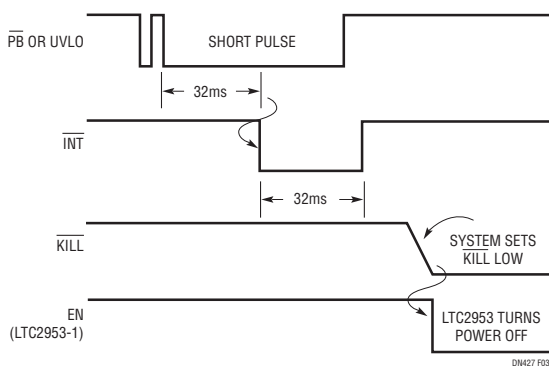

Figure 3. Orderly Power Off

Data Sheet Download

www.linear.com

detects 3 types of aberrant behavior at the input supply. If the supply glitches for longer than 32ms, the LTC2953 will issue an interrupt signal. If the supply falls and stays below the user adjustable level, the LTC2953 will turn off system power after the user-adjustable timer expires. Additionally, the UVLO comparator prevents a user from turning on system power if the input supply is too low (see Figure 4). The power fail is a general purpose uncommitted comparator, useful for distinguishing between a  $\overline{\text{PB}}$  interrupt and a low supply interrupt. The reset comparator is a single adjustable voltage monitor with fixed 200ms delay.

### Conclusion

The LTC2953 is a low power, wide input voltage range (2.7V to 27V) pushbutton on/off controller with input and output voltage monitoring. The LTC2953 provides a simple and complete solution for manually toggling power of many types of systems. Desirable features include a power fail comparator that issues an early warning of a decaying supply, along with a UVLO comparator that prevents a user from turning on a system with a low supply or dead battery. The LTC2953 provides even greater system reliability by integrating an adjustable single supply supervisor. Two versions of the part accommodate either positive or negative enable polarities. The device is available in a space saving 3mm  $\times$  3mm DFN package.

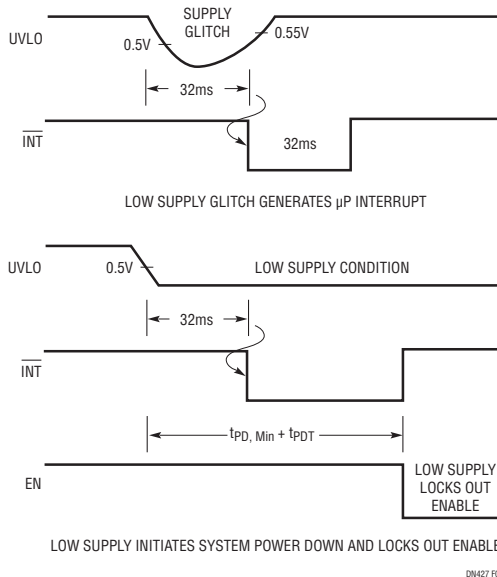

Figure 4. Multifunction UVLO Comparator

For applications help,  
call (408) 432-1900, Ext. 2602