

REVISIONS			
REV	DESCRIPTION	DATE	APPROVED

LTC3114-1 40V, 1A SYNCHRONOUS BUCK-BOOST DC/DC CONVERTER WITH PROGRAMMABLE OUTPUT CURRENT

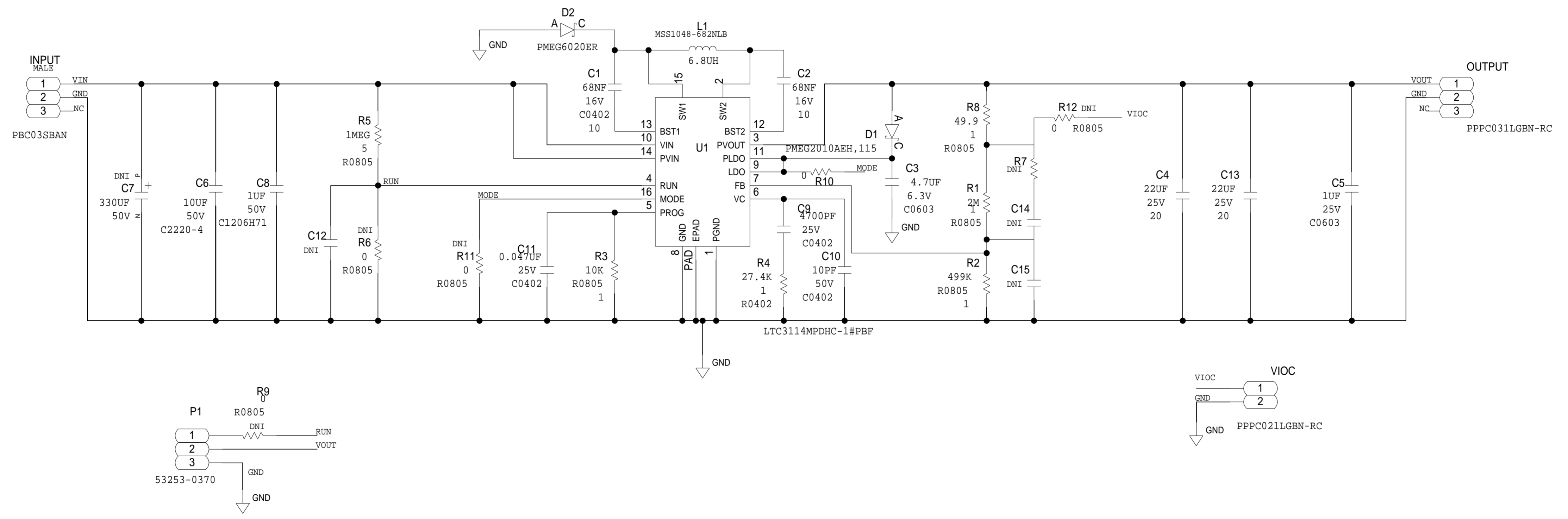

	SCHEMATIC		
	HW TYPE : Customer Evaluation		
	Product(s) : LTC3114-1		
	: NA		
DESIGN VIEW <DESIGN_VIEW>	DRAWING NO. 02_059797	REV A	
PTD ENGINEER J VIERNES	SIZE D	SCALE 1:1	SHEET 2 OF 2