

DESCRIPTION

Demonstration circuit 441 is a constant-frequency step-down converter, using the LTC3411 monolithic synchronous buck regulator. The DC441 has an input voltage range of 2.65V to 5.5V, and is capable of delivering up to 1.25A of output current. In Burst Mode™ operation, the DC supply current is typically only 240µA at no load, and less than 1µA in shutdown. In switching-noise sensitive applications, pulling the MODE pin to SGND inhibits

Burst Mode™ operation. These features, plus the LTC3411 coming in a small 10-Pin MS package and having an operating frequency of 1MHz (allowing the exclusive use of low profile surface mount components), make the DC441 demo board an ideal circuit for use in battery-powered, hand-held applications.

Design files for this circuit board are available. Call the LTC factory.

QUICK START PROCEDURE

Demonstration circuit 441 is easy to set up to evaluate the performance of the LTC3411. Refer to Figure 1 for proper measurement equipment setup and follow the procedure below:

NOTE: When measuring the output ripple, see Figure 2 for proper scope probe technique.

1. Select the desired output voltage using jumper JP2. The fixed output voltages are 1.8V, 2.5V, and 3.3V (as shown). There is also an option to set the output voltage to a custom value by inserting a resistor into the RFB5 pads next to jumper JP2.
2. Connect the input power supply to the Vin and GND terminals on the *left-side* of the board. Do not hot-

plug Vin or increase Vin over the rated maximum supply voltage of 5.5V, or the part may be damaged.

3. Connect the load between the Vout and GND terminals on the *right-side* of the board.
4. Select the desired operating mode using JP1. To select pulse-skipping mode, tie to ground by inserting the jumper into the rightmost position. Inserting the jumper into the leftmost position connects the pin to Vin, which allows Burst Mode™ operation.
5. To shut down the circuit, connect the SHDN/R_T pin to SV_{IN} by inserting the JP3 jumper into the rightmost position.

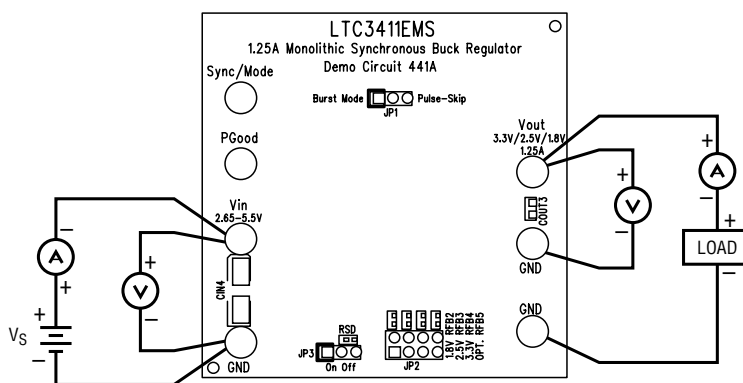

Figure 1. Proper Measurement Equipment Setup

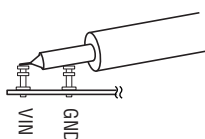
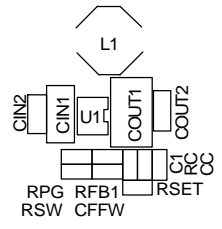
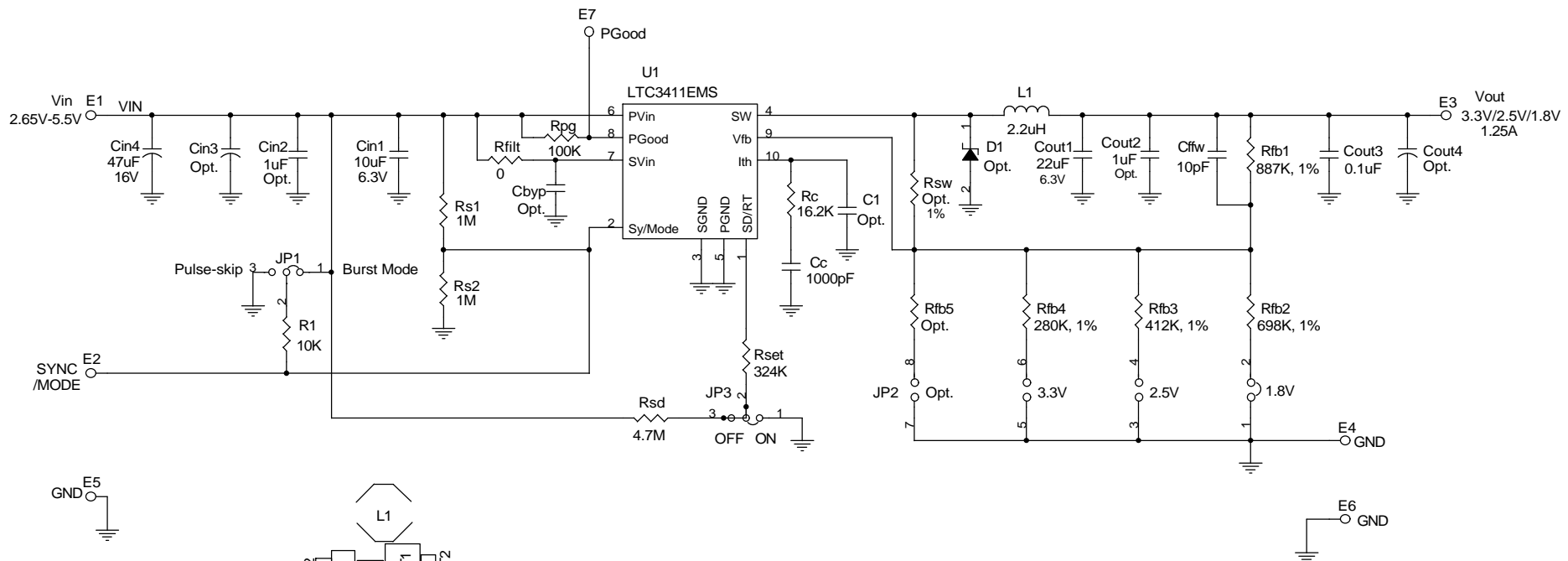



Figure 2. Scope Probe Placement for Measuring Output Ripple



PCB SILKSCREEN

CONTRACT NO.		 1630 McCarthy Blvd. Milpitas, CA 95035 Phone: (408)432-1900 Fax: (408)434-0507	
APPROVALS			
DRAWN	June Wu	6/28/01	TITLE LTC3411EMS Buck Regulator: 2.65V-5.5V->1.8V, 2.5V, or 3.3V@1.25A(max)
CHECKED			
APPROVED			
ENGINEER	Tom Gross	6/28/01	
DESIGNER			SIZE CAGE CODE DWG NO DEMO DC441A
Monday, March 11, 2002		SCALE:	REV A
		FILENAME:	SHEET 1 OF 1

Item	Qty	Reference	Part Description	Manufacture / Part #
1	0	Cbyp,Cout2,Cin2 (OPT)	CAP., 0603	
2	1	Cc	CAP., X7R, 1000pF, 25V, 20% 0402	AVX, 04023C102MAT
3	1	Cffw	CAP., NPO, 10pF, 50V, 10% 0402	AVX, 04025A100KAT
4	1	Cout1	CAP., X5R, 22uF, 6.3V, 10% 1210	MURATA, GRM32DR60J226KA01
5	1	Cin1	CAP., X5R, 10uF, 6.3V, 10% 1206	MURATA, GRM31CR60J106KC01
6	0	Cout4,Cin3 (OPT)	CAP., 6032, 7343	
7	1	Cout3	CAP., X7R, 0.1uF, 16V, 20% 0603	AVX, 0603YC104MAT
8	1	Cin4	CAP., TANT., 47uF, 16V, 20% 6032	AVX, TAJC476M016R
9	0	C1 (OPT)	CAP., 402	
10	0	D1 (OPT)	DIODE, SMA	
11	7	E1-E7	TESTPOINT, TURRET, .094"	MILL-MAX, 2501-2
12	2	JP1,JP3	0.079 SINGLE ROW HEADER 3 PIN	COMM CON, 2802S-03-G1
13	1	JP2	0.079X4 DOUBLE ROW HEADER	COMM CON, 2202S-08-G1
14	3	JP1,JP2,JP3	SHUNT,	COMM CON, CCIJ2MM-138G
15	1	L1	INDUCTOR, 2.2uH D52LC	TOKO, A914BYW-2R2M
16	1	Rc	RES.,CHIP, 16.2K, 1/16W, 5%, 0402	AAC, CR05-1622FM
17	1	R1	RES.,CHIP, 10K, 1/16W, 5%, 0402	AAC, CR05-103JM
18	1	Rfb1	RES.,CHIP, 887K, 1/16W, 1% 0402	AAC, CR05-8873FM
19	1	Rfb2	RES.,CHIP, 698K, 1/16W, 1% 0402	AAC, CR05-6983FM
20	1	Rfb3	RES.,CHIP, 412K, 1/16W, 1% 0402	AAC, CR05-4123FM
21	1	Rfb4	RES.,CHIP, 280K, 1/16W, 1% 0402	AAC, CR05-2803FM
22	0	Rfb5 (OPT)	RES., 1% 0402	
23	1	Rfilt	RES.,CHIP, 0, 1/16W, 0402	AAC, CJ05-000M
24	1	Rpg	RES.,CHIP, 100K, 1/16W, 5% 0402	AAC, CR05-104JM
25	1	Rset	RES.,CHIP, 316K, 1/16W, 1% 0402	AAC, CR05-3163FM
26	0	Rsw (OPT)	RES., 0402	
27	2	Rs1,Rs2	RES.,CHIP, 1M, 1/16W, 5% 0402	AAC, CR05-105JM
28	1	Rsd	RES.,CHIP, 4.7M, 1/16W, 5% 0402	AAC, CR05-475JM
29	1	U1	I.C., LTC3411, MS10	LINEARL, LTC3411EMS
30	1		PRINTED CIRCUIT BOARDS	DEMO BOARD DC441A
31	1		STENCIL	STENCIL DC441A
32	1		S / F	S / Frame, #10679, @ Flairis
			6-Boards to Alan 3/15/02	