

DESCRIPTION

Demonstration circuit 464 is a termination power supply that sinks or sources up to 12A current. Typical applications include termination power supplies for DDR or QDR memories. DC464 utilizes the LTC3718, a constant on-time, valley current mode synchronous buck controller with an integrated monolithic boost switcher that produces 5V bias for driving logic level MOSFETs. The demo circuit provides additional footprints for paralleling more MOSFETs and input/output capacitors for higher current applications. The output voltage (V_{OUT}) equals half of the reference voltage (V_{REF}). The default refer-

ence voltage is the input voltage, V_{IN} . An external reference can be provided to program the output voltage directly.

SPECIFICATIONS

- V_{IN} 2.5V typical, 1.5V–5V
- V_{OUT} $V_{IN}/2$
- I_{OUT} $\pm 10A$ continuous, $\pm 12A_{MAX}$ with air flow at 100LFM

SETUP NOTES

JUMPER SETTINGS

JP1: BOOST at **ON** position

JP2: VIN2 at **ON** position

QUICK START PROCEDURE

Refer to Figure 1 and Figure 2 for proper measurement equipment setup and follow the procedure below:

1. Connect the input 2.5V power source to the VIN and GND pins using wires capable of handling 6A current.
2. Turn on the input power supply. V_{OUT} should read about $V_{IN}/2 \pm 0.05V$. If V_{IN} is fixed at 2.5V, $V_{OUT} = 1.25V \pm 0.05V$

SOURCING CURRENT TEST (FIGURE 1)

3. Turn off the input power supply VIN first.
4. Connect the load to the VOUT and GND pins with the positive terminal of the load connecting to VOUT.
5. Turn on VIN.

EXTERNAL REFERENCE

The output of this demo board can be programmed by the external reference at the VREF pin.

NOTE: R4 must be removed *before* applying V_{REF} .

6. Increase the load current to 10A. V_{OUT} should always equal to $V_{IN}/2 \pm 0.05V$. If V_{IN} is fixed at 2.5V, V_{OUT} should read about $1.25V \pm 0.05V$.

SINKING CURRENT TEST (FIGURE 2)

7. Turn off the input power supply VIN first.
8. Connect the load to the VIN and VOUT pins with the positive terminal of the load connecting to VIN and the negative terminal of load connecting to VOUT.
9. Turn on VIN.
10. Increase the load current to 10A. If V_{REF} is fixed at 2.5V, V_{OUT} should read about $1.25V \pm 0.05V$.

QUICK START GUIDE FOR DEMONSTRATION CIRCUIT 464

DDR, HSTL, STTL TERMINATION POWER SUPPLY

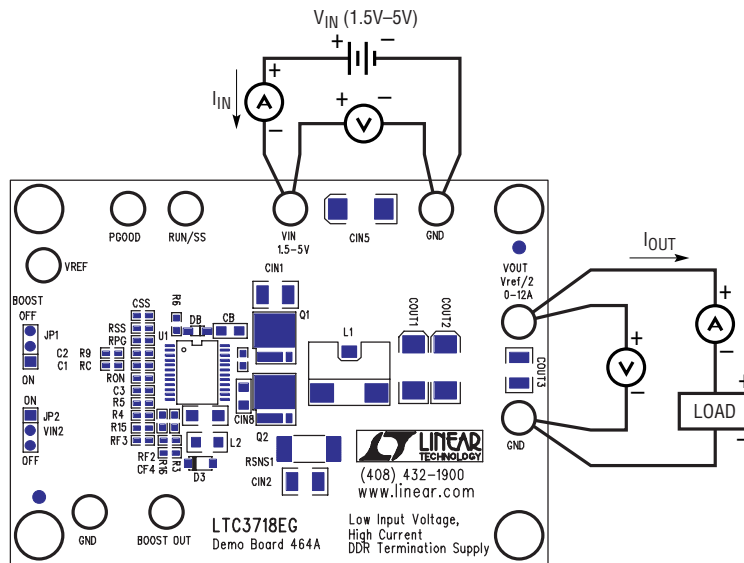

Figure 1. Proper Measurement Equipment Setup for Output Sourcing Current

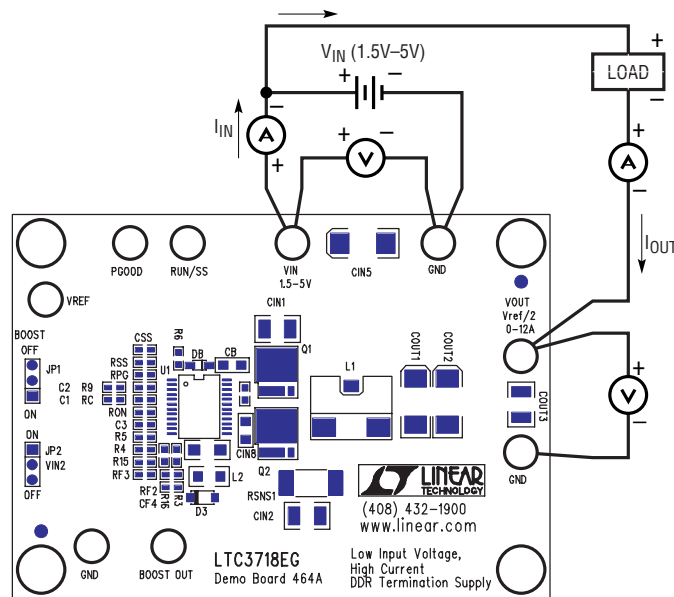

Figure 2. Proper Measurement Equipment Setup for Output Sinking Current