

DESCRIPTION

Demonstration circuit 648 is a high current step-down PolyPhase™ supply featuring the LTC3733 three-phase synchronous buck controller. It provides high performance power solutions for AMD Opteron™ and Athlon™ 64 processors. The switching frequency range of the LTC3733 is 210kHz to 530kHz. The input supply voltage range is 7V to 21V and the nominal VID programmable

output voltage is 0.8V-1.55V. To minimize the output capacitance, the Active Voltage Positioning (AVP) scheme is implemented on this board. The maximum output current of DC648 is 65A.

Design files for this circuit board are available. Call the LTC factory.

Table 1. Performance Summary

PARAMETER	CONDITION	VALUE
Minimum Input Voltage		7V
Maximum Input Voltage		21V
V _{OUT}	VID programmable nominal output voltage; AVP is implemented. Typical load line is 1mV/A.	0.8-1.55V
Nominal Switching Frequency	Set by resistor divider on the assembly	210kHz
Typical Efficiency	V _{IN} = 12V, V _{OUT} = 1.55V, I _{OUT} = 65A	86%

QUICK START PROCEDURE

Demonstration circuit 648 is easy to set up to evaluate the performance of the LTC3733CG in high current applications. Refer to Fig.1 for proper measurement equipment setup and follow the procedure below:

1. Preset the following jumpers on the demo board:

Jumper	DLC BIAS	DLC	FCB	5V SEL	B4-B0
Position	OFF	OFF	CCM	INT	00000

With the above jumper settings, the supply is running with 1.55V output and using the on board +5V bias supply.

2. Preset the voltage of the input power supply to 12V. Preset the current limit of the input power supply to greater than 18A. With power off, connect the input power supply to VIN+ and VIN-.
3. Connect the electronic load to VOUT+ and VOUT-. Preset the load current to 0A.
4. Turn on the power at the input.

5. Check for proper output voltages at no load and full load. AVP is implemented on this board. V_{out} = 1.560V to 1.598V when I_{out}=0A, and V_{out} = 1.502V to 1.540V when I_{out}=65A. A cooling fan is needed if the load current is greater than 50A.
6. Adjust the input voltage and load current within the operating range and observe the output voltage regulation, efficiency and other parameters. For input voltages higher than 14V, an external 5V bench supply is needed. Connect to +5V and GND pins to provide bias voltage to DC648. The 5V SEL jumper must be set to EXT.
7. (Optional) To perform the load transient test, set jumpers DLC BIAS-ON and DLC-ON. Use coaxial cables to connect LOAD STEP and Vout+ coaxial outputs to oscilloscope inputs. Adjust R38 and R34 for desired load current step and rising slope. Adjust R33 for desired load current falling slope.

QUICK START GUIDE FOR DEMONSTRATION CIRCUIT 648

3-PHASE AMD 64 PROCESSOR POWER SUPPLY

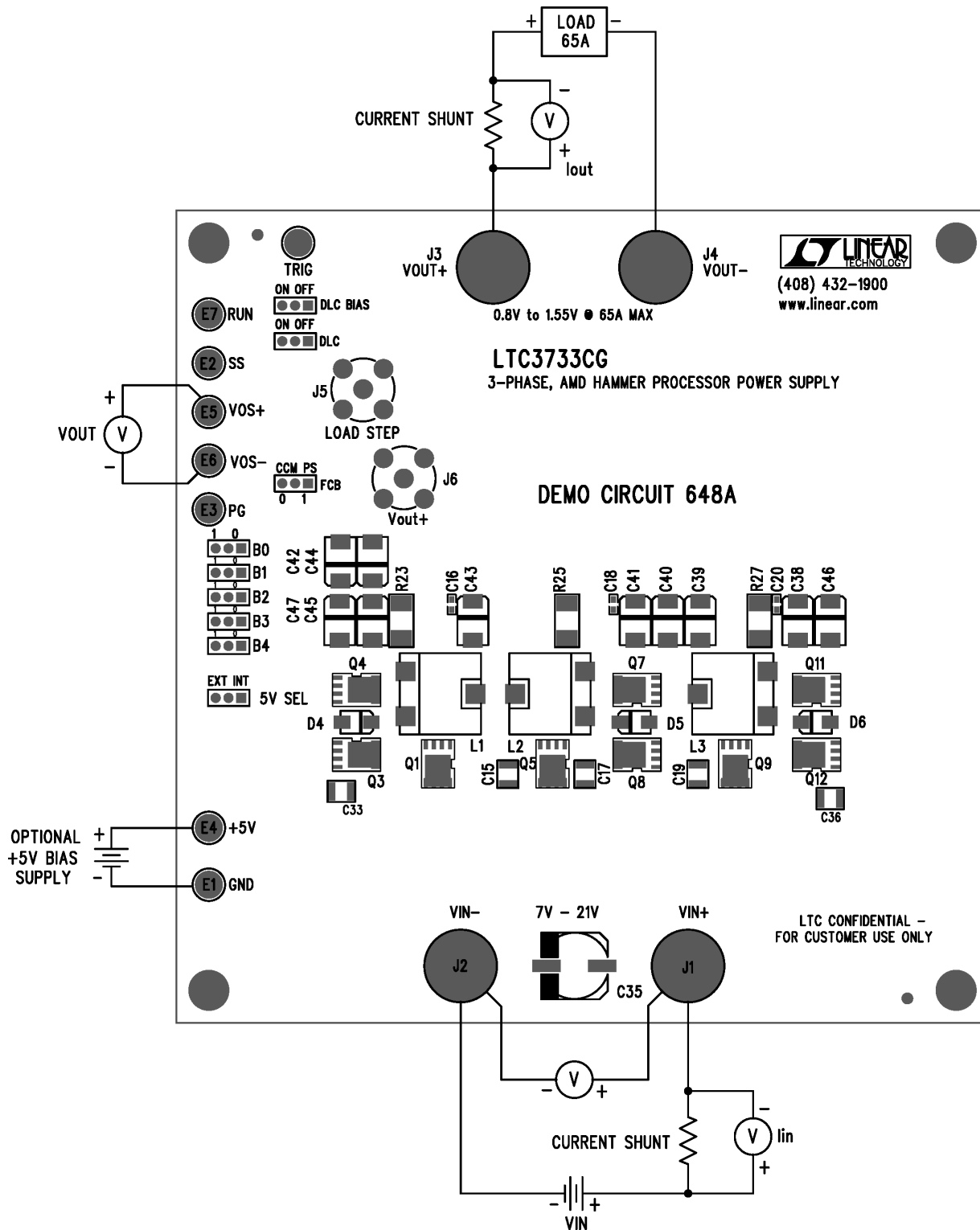
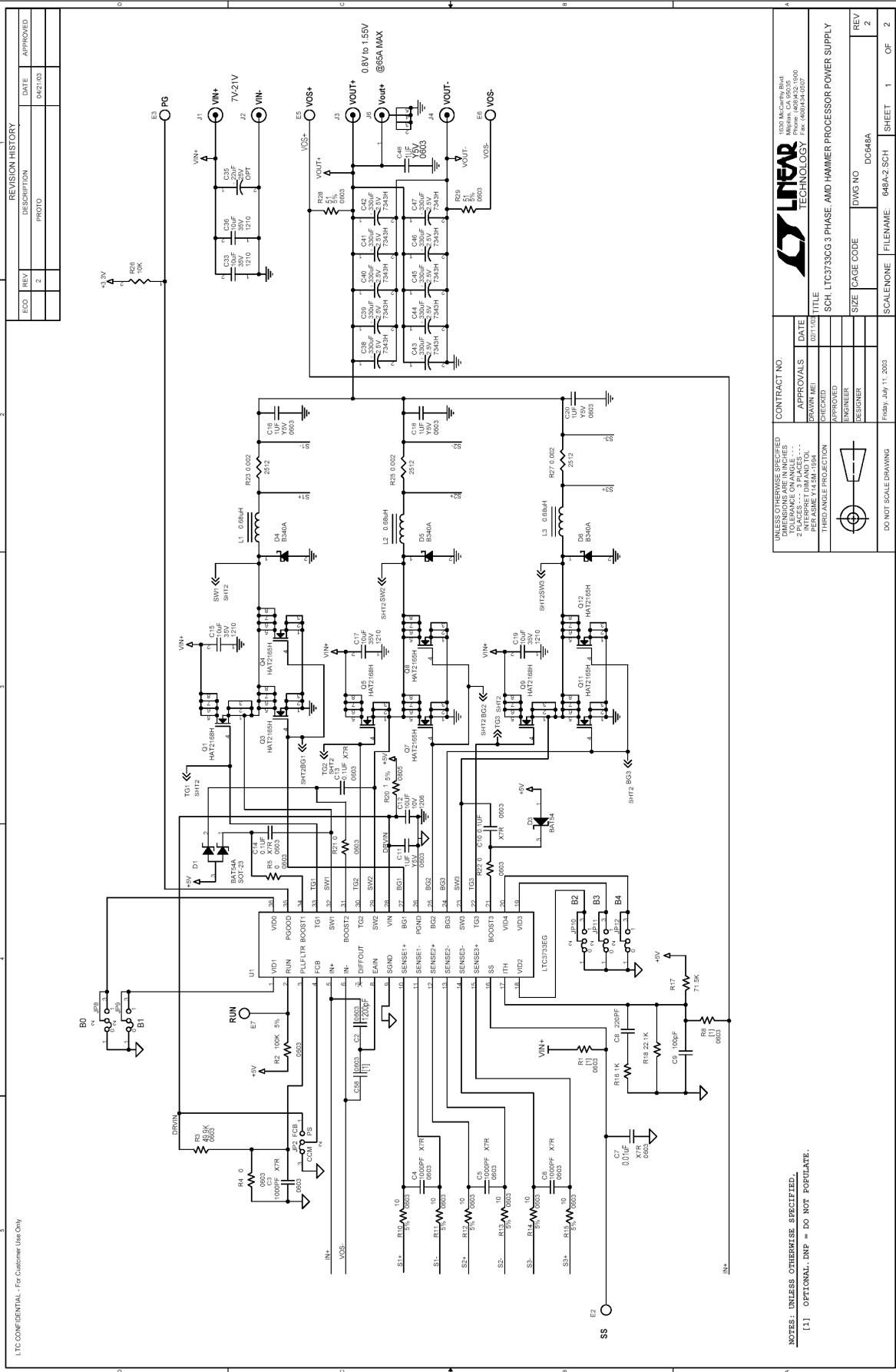

Figure 1. Proper Measurement Equipment Setup

QUICK START GUIDE FOR DEMONSTRATION CIRCUIT 648

3-PHASE AMD 64 PROCESSOR POWER SUPPLY



REVISION HISTORY				
ECO	REV	DESCRIPTION	DATE	APPROVED
	2		04/21/03	
	1	PROTO		

		1000 McCallum Blvd Fremont, CA 94539-1099 Phone: (925) 432-1000 Fax: (925) 432-1000	
CONTRACT NO.	DATE	TITLE	REV
APPROVALS	02/11/03	SCH. LTC3735CG 3 PHASE AMD HAMMER PROCESSOR POWER SUPPLY	2
DRAWN BY		SIZE	CAGE CODE
CHECKED		ENGINEER	DWG NO
APPROVED		DESIGNER	DC648A
ENGINEER			
DESIGNER			
	Friday, July 11, 2003	SCALE NONE	FILENAME: 648A.2.SCH
		SHEET	1 OF 2

UNLESS OTHERWISE SPECIFIED, DIMENSIONS ARE IN INCHES. DIMENSIONS IN PARENTHESES ARE FOR PRACTICAL CONSTRUCTION. INTERPRET DIMENSIONS AND TOLERANCES TO BE AS SHOWN. THIRD ANGLE PROJECTION.

DO NOT SCALE DRAWING

NOTES: UNLESS OTHERWISE SPECIFIED, [1] OPTIONAL, DNP = DO NOT POPULATE.

QUICK START GUIDE FOR DEMONSTRATION CIRCUIT 648

3-PHASE AMD 64 PROCESSOR POWER SUPPLY

