

## Flyback Controller Improves Cross Regulation for Multiple Output Applications – Design Note 344

Tom Hack

### Introduction

Flyback converters are often used in power supplies requiring low to medium output power at several output voltages. With a flyback, multiple outputs incur little additional cost or complexity—each additional output requires only another transformer winding, rectifier and output filter capacitor. Power over Ethernet (PoE) applications may require several low to medium power outputs and are good candidates for multiple output flyback converters.

While multiple output flyback converters are simple and inexpensive, they often suffer from poor cross regulation. Usually, one output is tightly regulated via feedback, while the other outputs are controlled via less accurate transformer action. Schottky diode voltage drops, transformer leakage inductances and transformer winding resistances degrade regulation.

Also, outputs remain uncoupled when the rectifiers are off, which contributes to poor cross regulation.

The LTC<sup>®</sup>3806 is a new flyback controller that improves load and cross regulation for multiple output flyback converters. Multi-output systems that previously used post regulators, multiple switching supplies or other methods to provide tight output voltage tolerances can now use lower cost flyback converters. The LTC3806 uses forced continuous conduction operation improving cross regulation by keeping the rectifiers on and the outputs coupled (via transformer action) for a larger fraction of each power conversion cycle. The LTC3806 also uses synchronous rectification to reduce rectifier voltage drops, improving converter efficiency and load regulation.

LT, LTC, LTM, Linear Technology and the Linear logo are registered trademarks of Linear Technology Corporation. All other trademarks are the property of their respective owners.

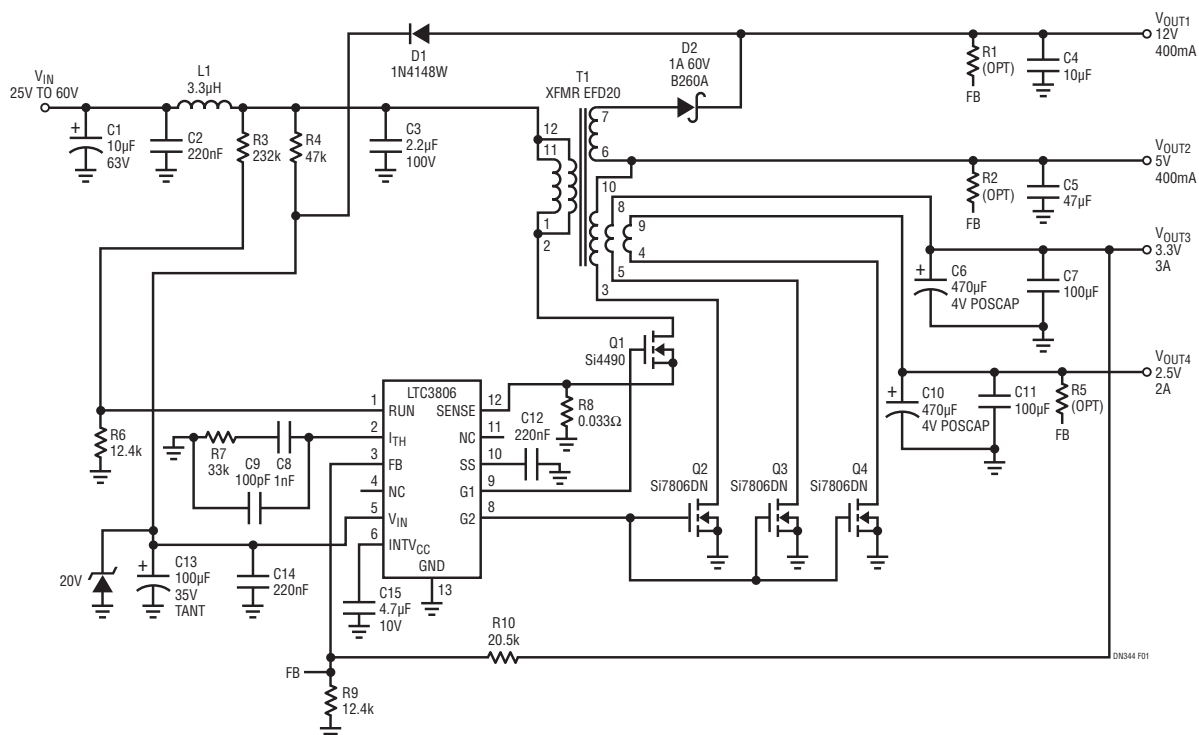

Figure 1. Multiple Output Synchronous Flyback Converter

## Improved Load and Cross Regulation

Figure 1 shows a multiple output flyback converter that takes full advantage of the features of the LTC3806. Performance of this design was compared against a nonsynchronous version created by replacing Q2 with an SL13 Schottky rectifier, and Q3 and Q4 with B540C Schottky rectifiers.

Load regulation measurements were taken with one output swept from no load to maximum output current while all other outputs delivered maximum output current. Table 1 shows how load regulation is improved in the synchronous design. Load regulation for output 1 and output 4 in the nonsynchronous design are given only from 20% to 100% of maximum output current because load regulation rapidly deteriorates below 20% of maximum output current.

Cross regulation measurements were taken under the same conditions as the load regulation measurements. Table 2 shows the superior cross regulation performance of the synchronous design.

**Table 1. Load Regulation (%  $V_{OUT}$ )**

	OUTPUT 1	OUTPUT 2	OUTPUT 3	OUTPUT 4
Synchronous	7.86%	6.31%	1.39%	9.47%
Nonsynchronous	8.88% (20%-100% of $I_{MAX}$ )	6.42%	2.43%	10.32% (20%-100% of $I_{MAX}$ )

**Table 2. Cross Regulation (%  $V_{OUT}$ )  
(Nonsynchronous Results in Parenthesis)**

OUTPUT 1	OUTPUT 2	OUTPUT 3	OUTPUT 4
Swept*	0.87% (2.02%)	0.22% (0.42%)	0.29% (0.43%)
0.31% (0.94%)	Swept	0.16% (0.23%)	0.17% (0.30%)
-5.49% (-8.52%)	-4.88% (-8.20%)	Swept	-4.43% (-8.61%)
-0.63% (-0.36%)	-0.12% (0.13%)	0.16% (0.39%)	Swept*

\*20% to 100% of  $I_{MAX}$  for nonsynchronous

The case for using synchronous rectification is even stronger when load and cross regulation measurements are taken with one output swept, and all other outputs unloaded. Synchronous rectification provides acceptable load and cross regulation while Schottky

rectification does not. To get reasonable regulation in a nonsynchronous design, all outputs require preloading of several percent of maximum  $I_{OUT}$ .

## Efficiency

Peak efficiency for this design is 87.6% at 60% of maximum output power (Figure 2). Such high efficiency is possible because of the significant reduction in conduction loss afforded by the synchronous rectification, particularly with low voltage outputs. At full load (21.4W total output power), supply dissipation is only 3.38W. For the nonsynchronous design, peak efficiency is 81.9% and power dissipation is 5.31W. If light load regulation is required, this degrades to 78.9% due to preloading.

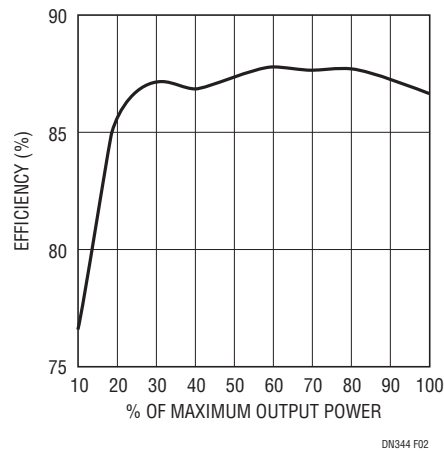

**Figure 2. Efficiency vs Output Power**

## Composite Feedback Provides Additional Design Flexibility

In Figure 1, only output 3 is controlled via feedback while the remaining outputs are set via transformer action. To further improve load and cross regulation on these other outputs (though at the expense of degraded load and cross regulation on output 3), composite feedback may be used by adding optional resistors R1, R2, and R5.

## Conclusion

The LTC3806 makes cost effective multiple output flyback converters attractive for low and medium power applications such as Power over Ethernet devices. Improved load and cross regulation eliminates the need for additional switching supplies or post regulators. Synchronous rectification improves efficiency and lowers power dissipation.

**Data Sheet Download**

[www.linear.com](http://www.linear.com)

For applications help,  
call (408) 432-1900

**Linear Technology Corporation**  
1630 McCarthy Blvd., Milpitas, CA 95035-7417  
(408) 432-1900 • FAX: (408) 434-0507 • [www.linear.com](http://www.linear.com)

dn344f\_conv LT/TP 0804 435K • PRINTED IN THE USA

**LINEAR**  
TECHNOLOGY  
© LINEAR TECHNOLOGY CORPORATION 2004