

DESIGN NOTES

Direct Efficient DC/DC Conversion of 100V Inputs for Telecom/Automotive Supplies – Design Note 398

Greg Dittmer

Introduction

Automotive, telecom and industrial systems have harsh, unforgiving environments that demand robust electronic systems. In telecom systems the input rail can vary from 36V to 72V, with transients as high as 100V. In automotive systems the DC battery voltage may be 12V, 24V or 42V with load dump conditions causing transients up to 60V or more. The LTC[®]3810 is a current mode synchronous switching regulator controller that can directly step down input voltages up to 100V, making it ideal for these harsh environments. The ability to step down the high input voltage directly allows a simple single inductor topology, resulting in a compact high performance power supply—in contrast to the low side drive topologies that require bulky, expensive transformers.

Feature-Rich Controller

The LTC3810 drives two external N-channel MOSFETs using a synchronizable constant on-time, valley current mode architecture. A high bandwidth error amplifier provides fast line and load transient response. Strong 1Ω gate drivers minimize switching losses—often the dominant loss component in high voltage supplies—even when multiple MOSFETs are used for high current applications. The LTC3810 includes an internal linear regulator controller to generate a 10V IC/driver supply from the high voltage input supply with a single external SOT23 MOSFET. When the output voltage is above 6.7V, the 10V supply can be generated from the output, instead of the

LT, LTC and LTM are registered trademarks of Linear Technology Corporation. No R_{SENSE} is a trademark of Linear Technology Corporation. All other trademarks are the property of their respective owners.

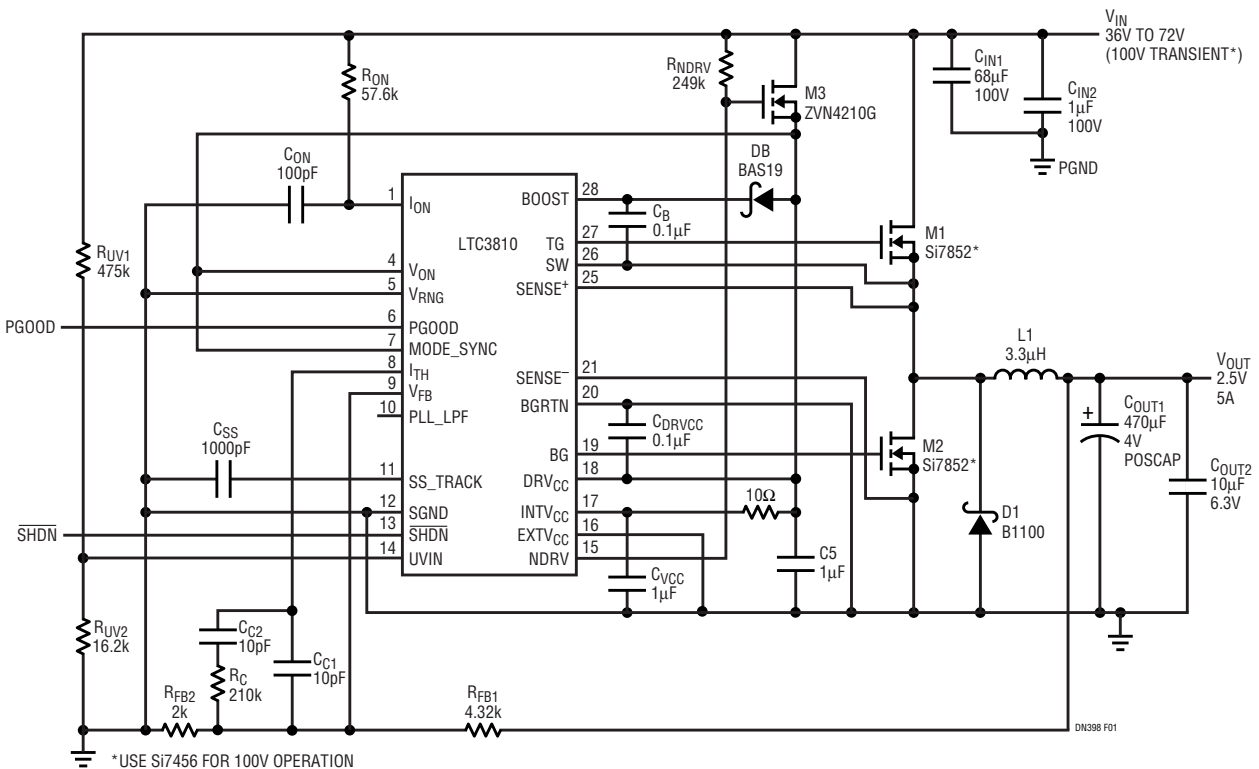

Figure 1. Compact 36V–72V to 2.5V/6A Synchronous Step-Down Converter

input, for higher efficiency. Other features include:

- Programmable cycle-by-cycle current limit, with tight tolerances, provides control of the inductor current during a short-circuit condition. No R_{SENSE}^{TM} current sensing utilizes the voltage drop across the synchronous MOSFET to eliminate the need for a current sense resistor.
- Low minimum on-time (<100ns) for low duty cycle applications. The on-time is programmable with an external resistor and is compensated for changes in input voltage to keep switching frequency relatively constant over a wide input supply range.
- Precise 0.8V, $\pm 0.5\%$ reference over the operating temperature range of 0°C to 85°C.
- Phase-locked loop for external clock synchronization, selectable pulse-skip mode operation, tracking, programmable undervoltage lockout and power good output voltage monitor.
- 28-pin SSOP package with high voltage pin spacing.

High Efficiency 36V–72V to 2.5V/6A Power Supply

The circuit shown in Figure 1 provides direct step-down conversion of a typical 48V telecom input rail to 2.5V at 5A. With the 100V maximum DC rating of the LTC3810 and 80V for the MOSFETs, the circuit can handle input voltages of up to 80V without requiring protection devices (up to 100V if appropriate MOSFETs are used). This circuit demonstrates how the low minimum on-time of the LTC3810 enables high step-down ratio applications: 2.5V output from a 72V input at 250kHz is a 140ns on-time.

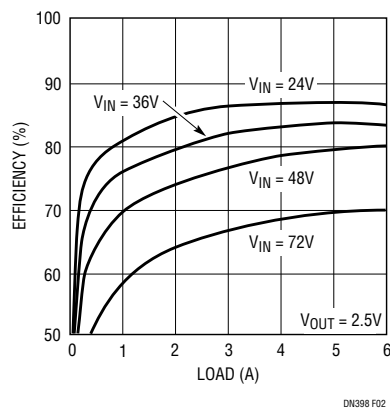

Figure 2. Efficiency of the Circuit in Figure 1

Data Sheet Download

www.linear.com

The frequency is set to 250kHz with the R_{ON} resistor to optimize efficiency while minimizing output ripple. Figure 2 shows mid-range efficiencies of 80% to 84% at 36V input and 65% to 70% at 72V input. Type II compensation is used to set the loop bandwidth to about 75kHz, which provides a 20 μ s response time to load transients (see Figure 3).

The V_{RNG} pin is set to 0V to set the current limit to about 8A (3A after foldback) during a short-circuit condition (see Figure 4). The resistor divider (R_{UV1} , R_{UV2}) sets the input supply undervoltage lockout to 24V, keeping the LTC3810 shut-down until the $V_{IN} > 24V$.

The LTC3810's internal linear regulator controller generates the 10V IC/driver supply ($INTV_{CC}$, DRV_{CC} pins) from the input supply with a single external MOSFET, M3. For continuous operation the power rating of M3 must be at least $(72V - 10V) \cdot (0.02A) = 1.2W$. If another low voltage supply (between 6.2V and 14V) capable of supplying the ~20mA IC/driver current is available, this supply could be connected to $INTV_{CC}/DRV_{CC}$ pins to increase efficiency by up to 10% at loads above 1A.

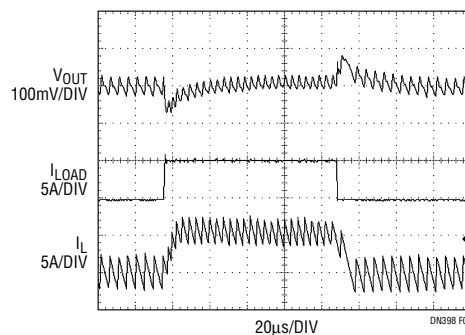

Figure 3. Load Transient Performance of Figure 1 Circuit Shows 20 μ s Response Time to a 5A Load Step

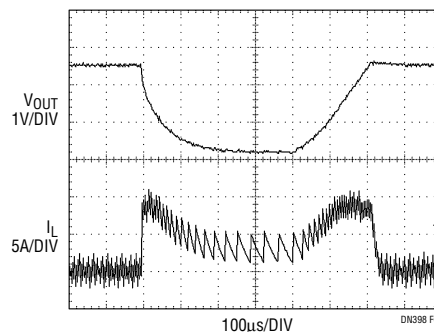

Figure 4. Short-Circuit Condition in Figure 1 Circuit Shows Tight Control of Inductor Current and Foldback

For applications help,
call (408) 432-1900, Ext. 2134