

DESCRIPTION

Demonstration circuit 470 is a termination power supply that sinks or sources up to 12A current. Typical applications include termination power supplies for DDR or QDR memories. DC470 utilizes the LTC3831, a voltage mode synchronous buck controller. The demo circuit provides additional footprints for paralleling more MOSFETs and input/output capacitors for higher current applications. The output voltage (V_{OUT}) equals half of the reference voltage (V_{REF}). An external reference can be provided to program the output voltage directly. In the

absence of the external reference, the potentiometer R11 can be used to adjust the output voltage.

SPECIFICATIONS

- V_{IN} 5V typical (3V–8V)
- V_{OUT} $V_{REF}/2$, preset at 1.25V by R11
- I_{OUT} $\pm 10A$ continuous, $\pm 12A_{MAX}$ with air flow 100LFM and 5V input

SETUP NOTES

3.3V INPUT OPERATION

The demo board uses a Si7440DP, a logic level MOSFET, to optimize for the 5V input application. If the input voltage is 3.3V, this MOSFET is not the best option. To achieve the best performance, one of the following 2 options must be implemented. Otherwise, the MOSFETs may not be properly driven and the circuit may not produce the rated currents.

- Replace Power MOSFETs Q1 and Q3 with sub-logic level MOSFETs such as Si7448DP

- Stuff the optional triple charge pump circuit consisting of D4, D5 and C9 and *depopulate R17*.

EXTERNAL REFERENCE

The output of this demo board can be programmed by the external reference at the VREF pin.

NOTE: R11 and R10 must be removed *before* applying VREF.

QUICK START PROCEDURE

Refer to Figure 1 and Figure 2 for proper measurement equipment setup and follow the procedure below:

1. Connect the input 5V power source to the VIN and GND pins using wires capable of handling 6A current. If required, connect the reference voltage V_{REF} for the V_{OUT} to the VREF pin.
2. Turn on the 5V input power supply. Adjust R11 such that $V_{REF} = 2.5V$.
3. Measure V_{OUT} . It should read about $1.25V \pm 0.05V$.

SOURCING CURRENT TEST (FIGURE 1)

4. Turn off the input power supply V_{IN} first.
5. Connect the load to the VOUT and GND pins with the positive terminal of the load connecting to VOUT.

6. Turn on V_{IN} .
7. Increase the load current to 12A. If V_{REF} is fixed at 2.5V, V_{OUT} should read about $1.25V \pm 0.05V$

SINKING CURRENT TEST (FIGURE 2)

8. Turn off the input power supply V_{IN} first.
9. Connect the load to the VIN and VOUT pins with the positive terminal of the load connecting to VIN and the negative terminal of load connecting to VOUT.
10. Turn on V_{IN} .
11. Increase the load current to 12A. If V_{REF} is fixed at 2.5V, V_{OUT} should read about $1.25V \pm 0.05V$.

DEMO BOARD QUICK START GUIDE 470

HIGH EFFICIENCY TERMINATION/TRACKING POWER SUPPLY

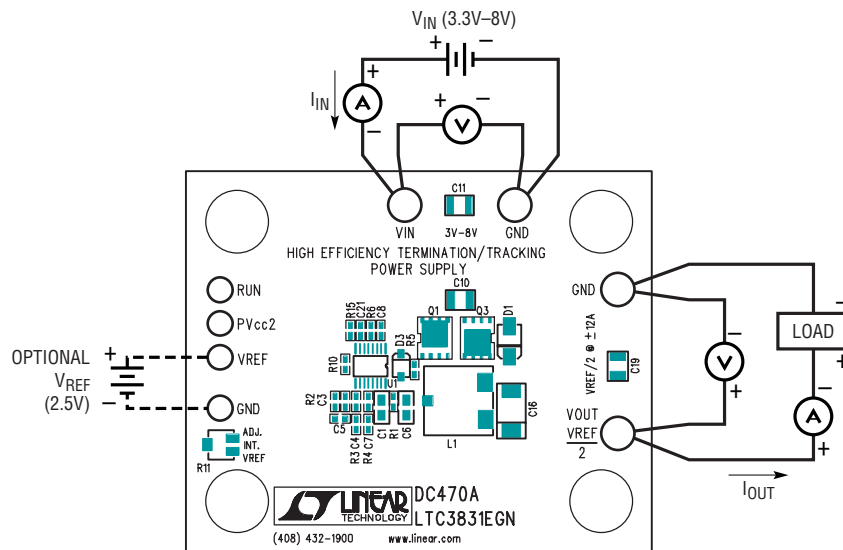

Figure 1. Proper Measurement Equipment Setup for Output Sourcing Current

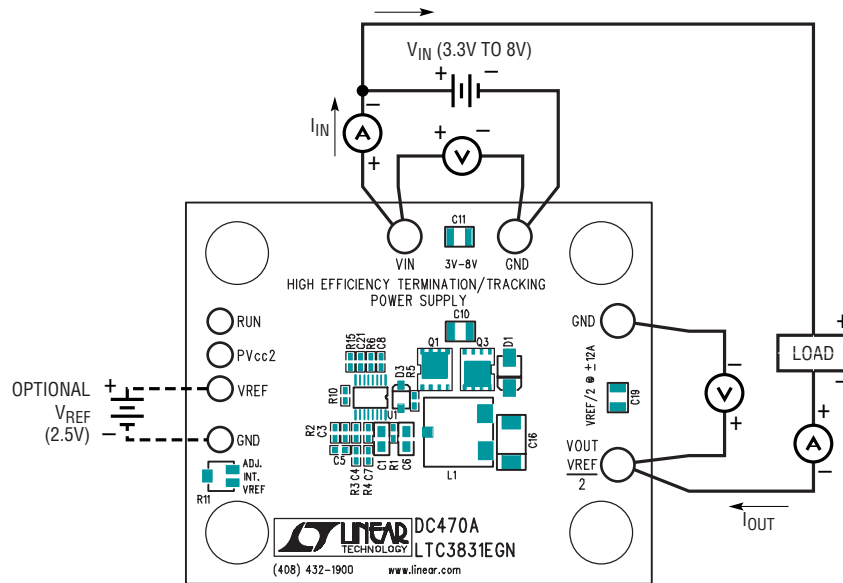

Figure 2. Proper Measurement Equipment Setup for Output Sinking Current