

QUICK START GUIDE FOR DEMONSTRATION CIRCUIT 1346A SINGLE 5A LOW QUIESCENT CURRENT STEP-DOWN DC/DC CONVERTER

LTC3834EGN-1

DESCRIPTION

Demonstration circuit 1346A is a low quiescent current step-down DC/DC converter featuring the LTC[®]3834-1 in a 16-pin GN package. The DC1346A is programmed to generate a regulated 3.3V@5A output from a 4.5V to 32V input voltage.

To maximize battery usage, the demo circuit allows low dropout operation when the input voltage is close to the output voltage. Its selectable burst mode operation reduces the IC supply current at light loads to extend battery life. The phase-lockable frequency allows the LTC3834-1 to be synchronized by an external signal. The output voltage of the LTC3834-1 can track an external ramp voltage signal during power-

up and power-down. Also, the built-in current fold-back prevents the overheating of output MOSFETs during short-circuit.

All these features make the circuit a high performance solution for applications in automotive and battery-operated systems, telecom and distributed DC power systems.

Design files for this circuit board are available. Call the LTC factory.

LTC is a registered trademark of Linear Technology Corporation

Table 1. Performance Summary (T_A = 25°C)

PARAMETER	CONDITION	MINIMUM	TYPICAL	MAXIMUM
Input Voltage Range		4.5V		32V
Maximum Output Current	4.5V < V _{IN} < 32V		5A	
Output Voltage V _{OUT}	0A < I _{OUT} < 5A	3.234V	3.3V	3.366V
Output Ripple V _{OUT}	I _{OUT} = 5A (20MHz BW) V _{IN} = 36V, F _{SW} = 400kHz			36mV _{p-p}
Nominal Switching Frequency			400kHz	
Efficiency	V _{IN} = 14V, I _{OUT} = 3.5A, 400kHz Switching Frequency		91.5%	

QUICK START PROCEDURE

Demonstration circuit 1346A is easy to set up to evaluate the performance of the LTC3834EGN-1. Refer to 0 for proper measurement equipment setup and follow the procedure below:

NOTE: When measuring the input or output voltage ripple, care must be taken to avoid a long ground lead on the oscilloscope probe. Measure the input or output voltage ripple by touching the probe tip directly across the Vin or Vout and GND terminals. See Figure 2 for proper scope probe technique.

1. Place VOUT jumper in the OFF position, the PLLPF jumper (JP2) at the selected frequency and the

MODE jumper (JP3) in desired Mode (Burst, CCM or DCM) position. Table 2 shows the default setting for DC1346A.

JP1 TRACK/SS	JP2 PLLPF	JP3 MODE	JP4 V _{OUT}
SS	400kHz	DCM	ON

Table 2. Default Jumper Settings

2. With power off, connect a 4.5V-32V, 6A power supply to VIN and GND.

QUICK START GUIDE FOR DEMONSTRATION CIRCUIT 1346A

SINGLE 5A LOW QUIESCENT CURRENT STEP-DOWN DC/DC CONVERTER

3. Connect a load to VOUT and GND (maximum load is 5A).
4. Move the VOUT jumper to the ON position.
5. Turn on the power at the input.

NOTE: Make sure that the input voltage is above 4.5V, but does not exceed 32V.
6. Check for proper output voltages. VOUT should measure 3.3V (could vary from 3.234V to 3.366V).

- NOTE:** If there is no output, temporarily disconnect the load to make sure that the load is not set too high.
7. Once proper output voltages are established, adjust the load within the operating range and observe the output voltage regulation, ripple voltage, efficiency and other parameters.

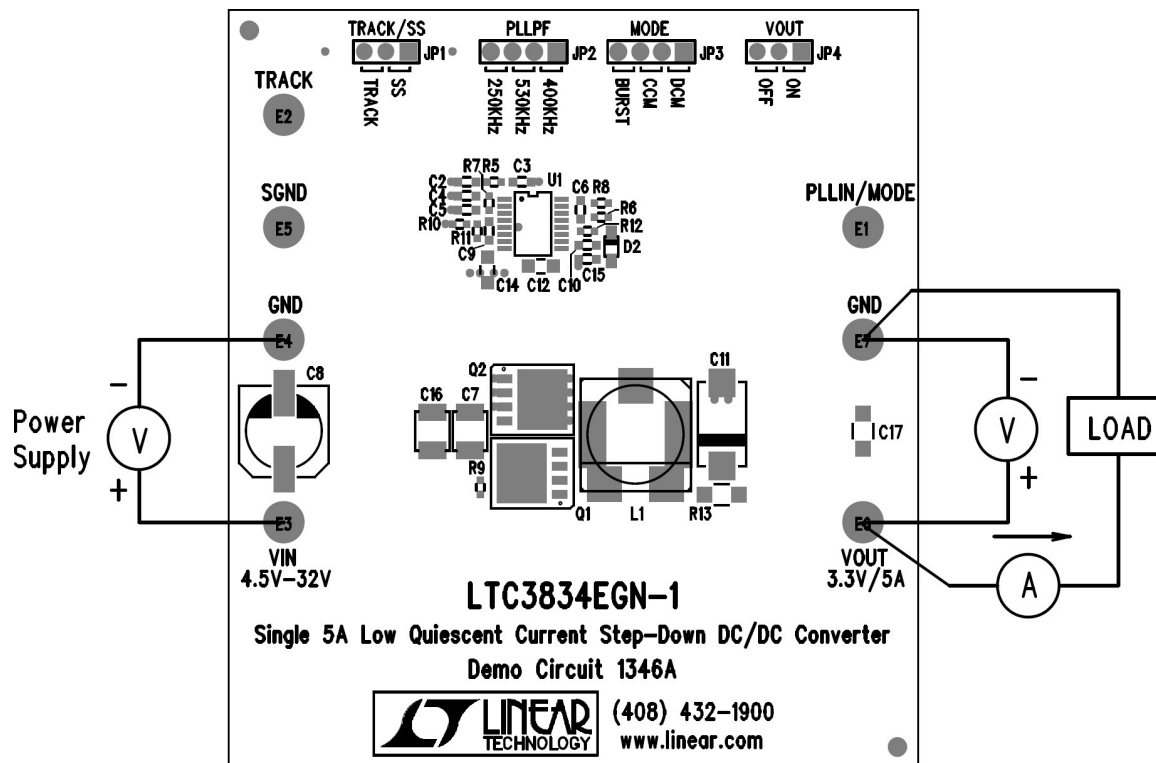

Figure 1. Proper Measurement Equipment Setup

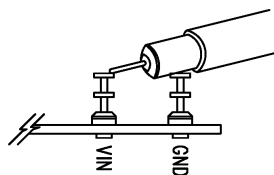
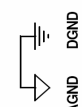
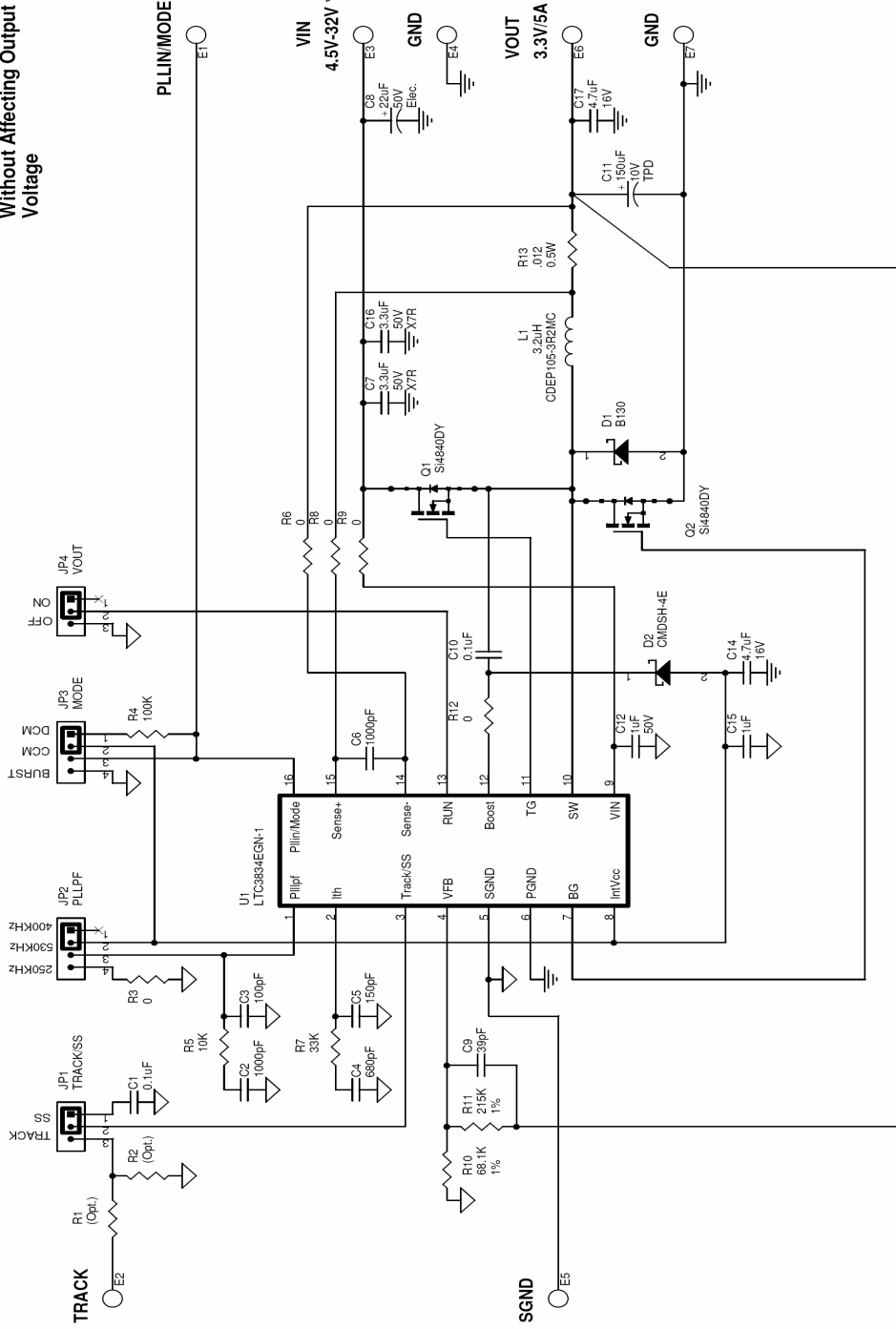

Figure 2. Measuring Input or Output Ripple

QUICK START GUIDE FOR DEMONSTRATION CIRCUIT 1346A

SINGLE 5A LOW QUIESCIENT CURRENT STEP-DOWN DC/DC CONVERTER

* Vin Can Drop As Low As 4V Without Affecting Output Voltage



LTC CONFIDENTIAL - FOR CUSTOMER USE ONLY

Customer Notice	
Linear Technology Has Made A Best Effort To Design A Circuit That Meets Customer-Supplied Specifications; However, It Remains The Customer's Responsibility To Verify Proper And Reliable Operation In The Actual Application. Component Substitution And Printed Circuit Board Layout May Significantly Affect Circuit Performance Or Reliability. Contact Linear Technology Applications Department For Assistance.	
This Circuit Is Proprietary To Linear Technology And Supplied For Use With Linear Technology Parts.	
LINEAR TECHNOLOGY CORPORATION	1630 MCCARTHY BLVD. MILPITAS, CA 95035 408-432-1900 408-434-0507 FAX
Title	Single 5A Low Quiescent Current Step-Down DC/DC Converter
Size	Document Number Demo Circuit 1346A
Date	LT3834EGN-1
Rev	Sheet 1 of 1

NOTES: UNLESS OTHERWISE SPECIFIED