

60V I²C Programmable Power

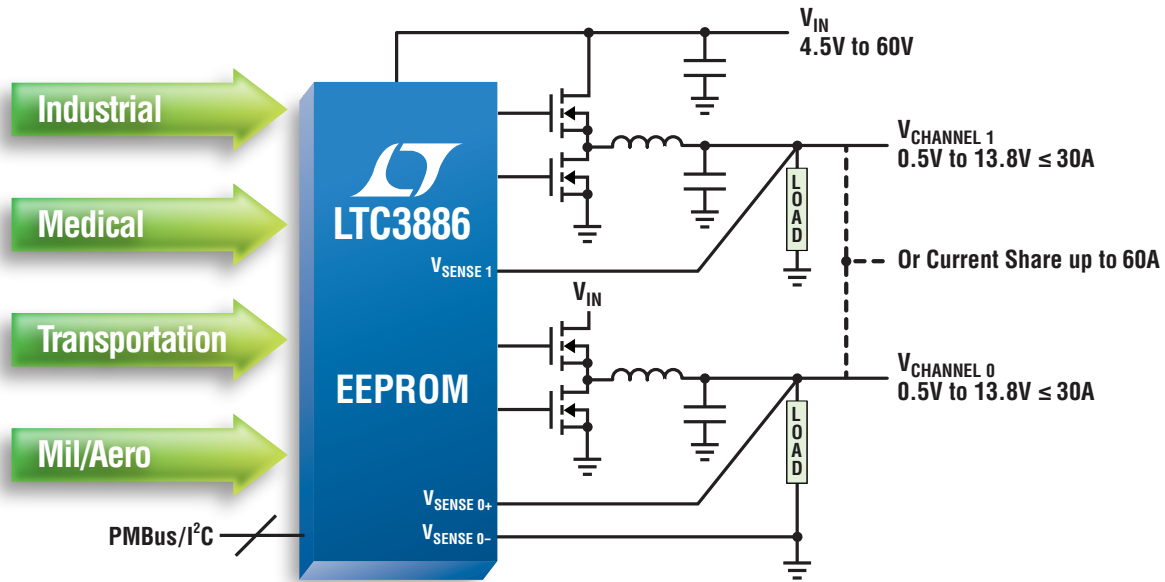

Digital Power System Management Gives Control & Telemetry

The LTC[®]3886, a dual output synchronous step-down controller, brings a new level of control, telemetry and digital power system management to high voltage switch-mode power supply design. With an input voltage range up to 60V, it can convert a 48V or 24V intermediate bus down to sub-1V in a single stage. Furthermore, it provides a new level of output accuracy with a total DC output error of less than $\pm 0.5\%$ over temperature. Its PMBus/I²C serial interface enables programming and telemetry read back of key parameters including control loop compensation and fault logging. The LTC3886 joins our broad digital power system management product family in our common platform development system, LTpowerPlay[™].

Features

- Input Voltage Range: 4.5V to 60V
- DC Output Error: < $\pm 0.5\%$ over Temp
- PMBus/I²C Complaint Serial Interface
- Programmable Control Loop Compensation
- Internal EEPROM and Fault Logging
- Accurate PolyPhase[®] Current Sharing for Up to 6 Phases
- LTpowerPlay Power Development System

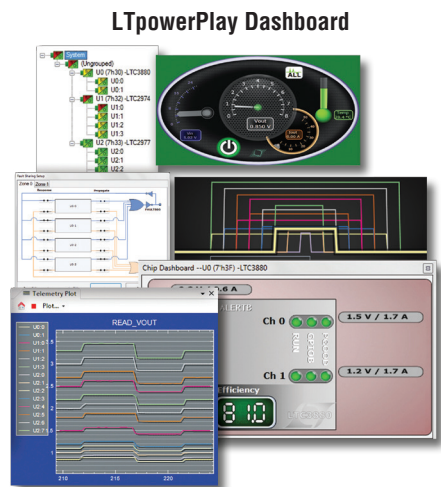

Info & Free Samples

www.linear.com/LTC3886

1-800-4-LINEAR

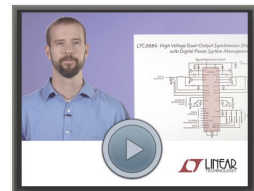

<http://www.linear.com/solutions/5761>

LT, LT, LTC, LTM, Linear Technology, the Linear logo and PolyPhase are registered trademarks and LTpowerPlay is a trademark of Linear Technology Corporation. All other trademarks are the property of their respective owners.