

REVISION HISTORY				
ECO	REV	DESCRIPTION	APPROVED	DATE
-	02	PRODUCTION	W. Li	07-29-2020

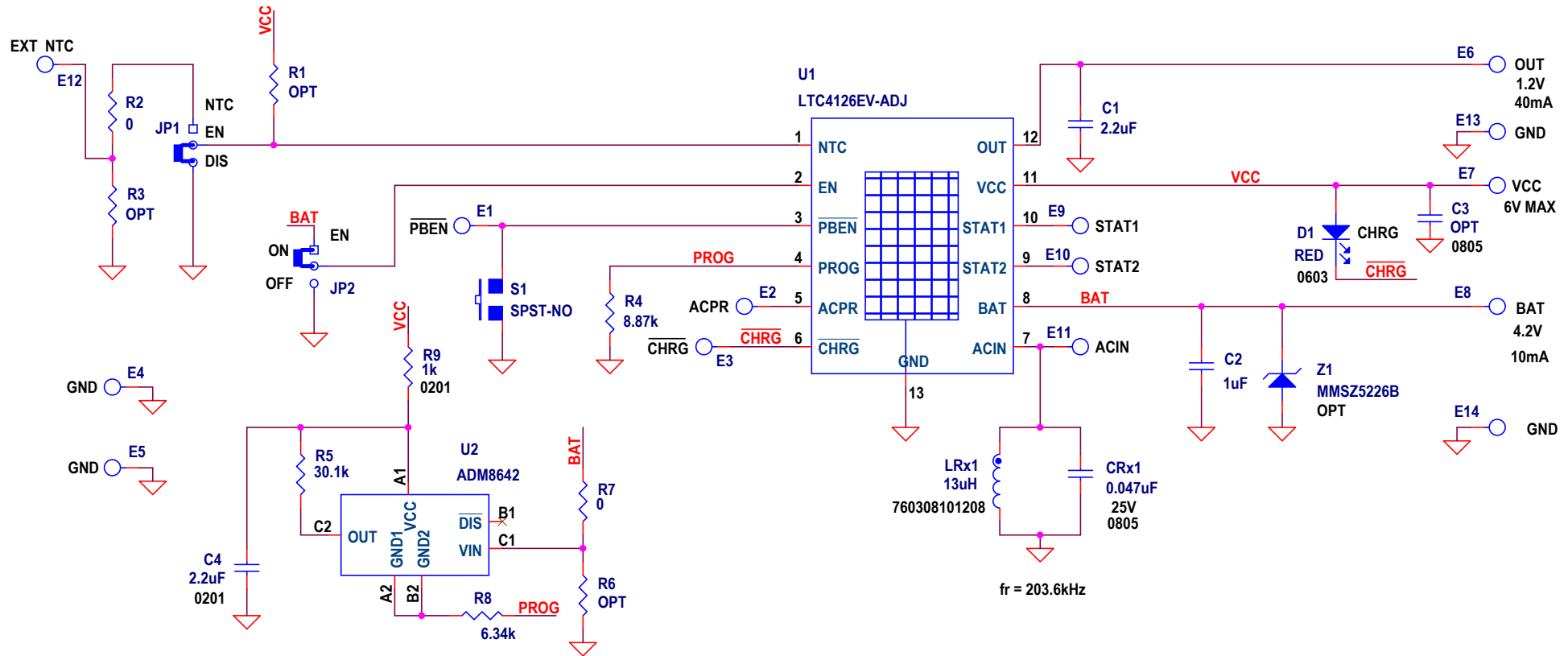

PCA ADDITIONAL PARTS

PCB1	PCB, DC3078A	REV02
LB1	LABEL	

UNLESS NOTED:
 RESISTORS: OHMS, 0402, 1%, 1/16W
 CAPACITORS: μ F, 0402, 10%, 50V

CUSTOMER NOTICE

LINEAR TECHNOLOGY HAS MADE A BEST EFFORT TO DESIGN A CIRCUIT THAT MEETS CUSTOMER-SUPPLIED SPECIFICATIONS; HOWEVER, IT REMAINS THE CUSTOMER'S RESPONSIBILITY TO VERIFY PROPER AND RELIABLE OPERATION IN THE ACTUAL APPLICATION. COMPONENT SUBSTITUTION AND PRINTED CIRCUIT BOARD LAYOUT MAY SIGNIFICANTLY AFFECT CIRCUIT PERFORMANCE OR RELIABILITY. CONTACT LINEAR TECHNOLOGY APPLICATIONS ENGINEERING FOR ASSISTANCE.

THIS CIRCUIT IS PROPRIETARY TO LINEAR TECHNOLOGY AND SUPPLIED FOR USE WITH LINEAR TECHNOLOGY PARTS.

APPROVALS

PCB DES.	NC
APP ENG.	W. LI

SCALE = NONE



www.analog.com

TITLE: SCHEMATIC
 10mA WIRELESS LI-ION CHARGER WITH 1.2V STEP-DOWN DC/DC CONVERTER AND TRICKLE CHARGE CONTROLLER

SIZE	IC NO.	LTC4126-ADJ	REV.
		DEMO CIRCUIT 3078A	02

DATE: 07-29-2020

SHEET 1 OF 1