



## Smart & Flexible High Current DC/DC Controllers Simplify Power Supplies in Telecom & Datacom Systems

By

**Bruce Haug**

**Senior Product Marketing Engineer**

**Linear Technology**

### **Background**

The increasing complexity and scalability being found in the next generation of routers and switches commonly found in telecom and datacom systems has exerted pressure on power supply manufactures to provide smart and flexible high efficiency solutions that can be scaled across multiple platforms. System designers will frequently have several variations of a base architecture, allowing them to offer high, medium and low-end systems, each with different feature sets. Examples of device types that can be added, removed or sized according to system needs are; content-addressable memory (CAM), ternary content-addressable memory (TCAM), application specific integrated circuits (ASICs), full custom silicon and field-programmable gate arrays (FPGAs).

A CAM is often described as the opposite of random access memory (RAM). To retrieve data on RAM, the operating system must provide the memory address where the data is stored. Data stored on CAM can be accessed by performing a query for the content and the memory retrieves the addresses where that data can be found and is much faster than RAM. You can be assured that any switch capable of forwarding ethernet frames at gigabit line-speed is using CAMs for lookups. In a system using RAM, the operating system would have to remember the address where everything was stored, whereas with CAMs, the operating system can find what it needs in a single operation.

A TCAM is a specialized type of high-speed memory that searches its entire contents in a single clock cycle. The term "ternary" refers to the memory's ability to store and query data using three different inputs: 0, 1 and X. The "X" input is often referred to as a "don't care" or "wildcard" state, which enables TCAM to perform broader searches based on pattern matching, as opposed to binary CAM, which performs exact-match searches using only 0s and 1s. Routers can store their entire routing table in these TCAMs, allowing for very quick lookups. TCAM's increase look-up speed, packet classification, packet forwarding, but it requires more power than a CAM. Both CAMs and TCAMs require very accurate set points and have tight voltage transient requirements that are very challenging for power system designers.

An ASIC is another device that can be used in routers and switches and is an integrated circuit (IC) that is customized for a particular use, rather than for general-purpose applications. Modern ASICs often include entire microprocessors, memory blocks including ROM, RAM, EEPROM, flash memory and other large building blocks. Such an ASIC is often termed a SoC

(system-on-chip) and these ASIC's can require hundreds of amps with core operating voltages in the range of 0.8 to 1.2V. As with TCAM and CAM, set point accuracy and transient response is critical to the overall performance of these solutions. Solution size and excellent current control are also key requirements for the power designer.

An FPGA is yet another device used in telecom and Datacom systems, and is an integrated circuit that is programmable. FPGAs are used in the design of specialized systems and allows users to tailor microprocessors to meet their own individual needs. These type of devices have several voltage inputs and their core power can require currents in excess of one hundred amps.

## **Scalability**

The amount of CAMs and TCAMs allocated to a particular switch or router depends on how a networking company positions its offering of low, medium or high-end systems. The more expensive systems will normally have sufficient CAM's and TCAM's to support the highest speeds, fastest look ups and highest throughputs. However, some consumers won't want to purchase a high end router unless they can justify the added cost. So there is a need to offer multiple platforms with different levels of functionality and price so it would be convenient if there were a DC/DC converter that could be scaled across different power levels and number of outputs to support multiple platforms.

Existing solutions routinely use a multiphase design, but with only one or two outputs. If there are more than two high current loads, users need to resort in using multiple controllers, which increases solution size, design complexity and cost. In addition, some of the existing power solutions require specialized power train devices that are not compatible with the standard DrMOS or power block devices. A new DC/DC controller from Linear Technology address' these needs, and allows scalability across multiple platforms which require both high current outputs, as well as dense multiple output point-of-load solutions.

## **A Smart IC Solution with Scalability**

Linear's LTC7851/-1 is a multiphase synchronous voltage mode step-down controller that gives users the flexibility to choose from one, two, three or four outputs and can deliver up to 40 amps per output depending on the choice of external components. All 4 phases can be combined to provide 160A for a core supply as an example, or provide 4 independent outputs that supports system power as well as an ASICs and various I/O power rails. The LTC7851/-1 works with DrMOS, power blocks as well as discrete N-channel MOSFETs plus associated gate drivers for the power train devices, enabling flexible design configurations. Up to 8 phases, with two ICs, can be paralleled and clocked out-of-phase to minimize input and output filtering for very high current requirements exceeding 260A. Up to 12 phases with three IC's can be clocked 30 degrees out-of-phase with the use of an external clock chip such as the LTC6902.

Furthermore, the LTC7851/-1's internal auxiliary current share loop equalizes current between phases when paralleled, enabling accurate current sharing between phases across multiple ICs, both in steady state and during a transient event. This not only mitigates one channel carrying

too much load current, but also eases the thermal design. It operates with a  $V_{CC}$  supply voltage from 3V to 5.5V and is designed for step-down conversion from an input voltage of 3V to 27V. It produces one to four independent output voltages ranging from 0.6V to 5V. The device's voltage mode control architecture allows for a selectable fixed operating frequency from 250kHz to 2.25MHz or it can be synchronized to an external clock over the same range. The output current is sensed by monitoring the voltage drop across the output inductor (DCR) for maximum efficiency or by using a low value sense resistor. The onboard differential amplifiers provide true remote output voltage sensing for all outputs for high accuracy regulation.

The LTC7851-1 is similar to the LTC7851, but with a lower current sense amplifier gain, ideal for power train applications using DrMOS with internal current sense. Additional features for each phase include current monitoring, adjustable current limit, programmable soft start or tracking and individual power good signals. It also maintains  $\pm 0.75\%$  output voltage accuracy over an operating temperature range of  $-20^{\circ}\text{C}$  to  $+85^{\circ}\text{C}$  and is available in a 58-lead 5mm x 9mm QFN package. It should be recognized that a well-designed accurate reference can greatly reduce the amount of bulk output capacitance required to meet the transient response of today's custom silicon and ASIC's. Figure 1 below shows a simplified schematic that converts a 10V to 14V input to a 0.95V at 160A output using DrMOS as the power train device,

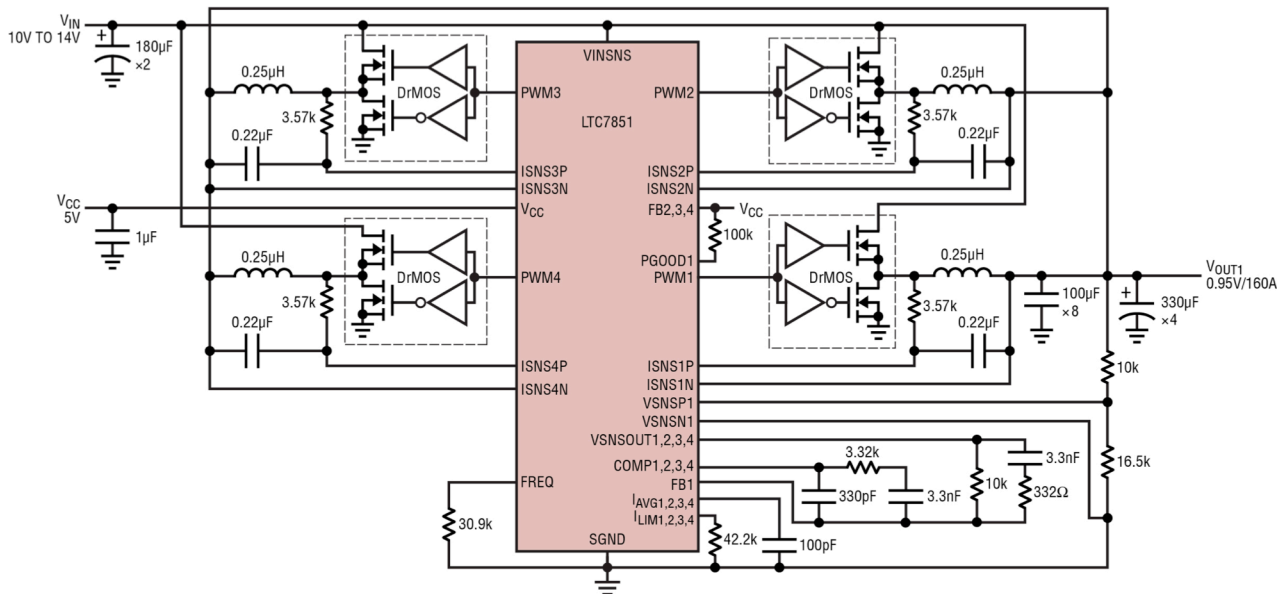

Figure 1. LTC7851 Simplified Schematic, Delivering a Single 0.95V/160A Output

## Efficiency

The LTC7851 efficiency curve in Figure 2 is representative of the Figure 1 circuit schematic and is shown with a 12V input voltage stepping down to 0.95V at up to 160 amp output current. Efficiencies of up to 94% can be achieved.

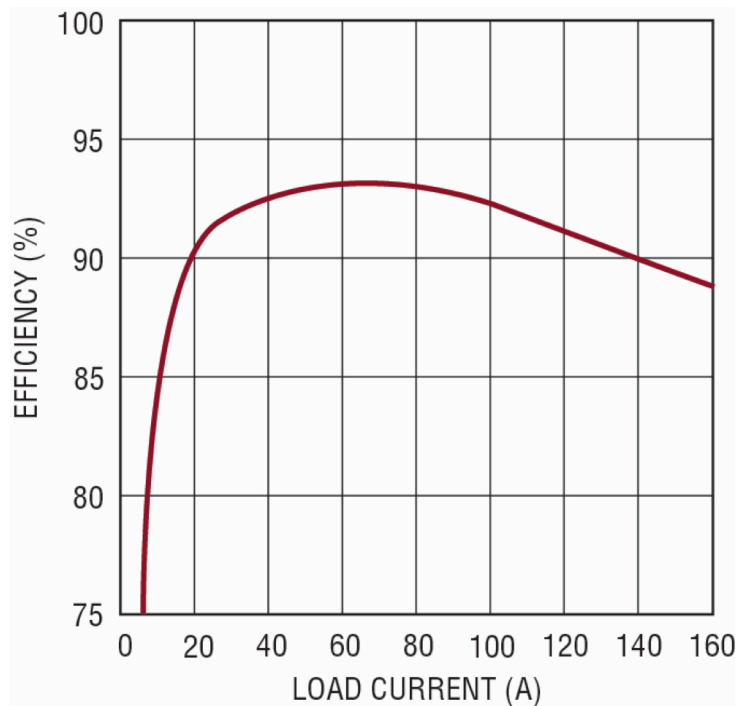

Figure 2. LTC7851 Efficiency Curves for a Single Output of 12V to 0.95V at 160A

## Current Balance

When multiple LTC7851/-1's channels are paralleled to drive a common load, accurate output current sharing is essential to achieve optimal performance and efficiency. Otherwise, if one stage is delivering more current than another, then the temperature between the two stages will be different, and that could translate into higher switch RDS(ON), lower efficiency, and higher RMS ripple. A mismatch of even a small amount here can greatly diminish the total power available in a multi-phase design.

For single output multiphase applications, the LTC7851/-1 incorporates an auxiliary current sharing loop, where the inductor current is sampled each cycle. The master controller's current sense amplifier output is averaged at the  $I_{AVG}$  pin. A small capacitor connected from  $I_{AVG}$  to GND (typically 100pF) stores a voltage corresponding to the instantaneous average current of the

master controller. The master phase and slave phases  $I_{AVG}$  pins are connected together and each slave phase integrates the difference between its current and the master. Within each phase the integrator output is proportionally summed with the system error amplifier voltage (COMP), adjusting that phase's duty cycle to equalize the currents. When multiple ICs are daisy chained, the  $I_{AVG}$  pins are connected together resulting in a current imbalance of a couple of percentage points. With the LTC7851's tight current sharing specifications, designers will be able to extract the maximum output current from today's DrMOS devices.

Figure 3 below shows the inductor current sense voltage for each of the four phases versus load current and how well they balance across the entire load range.

Figure 3. Four Phase Current Balance for a Single 0.95V/160A Output

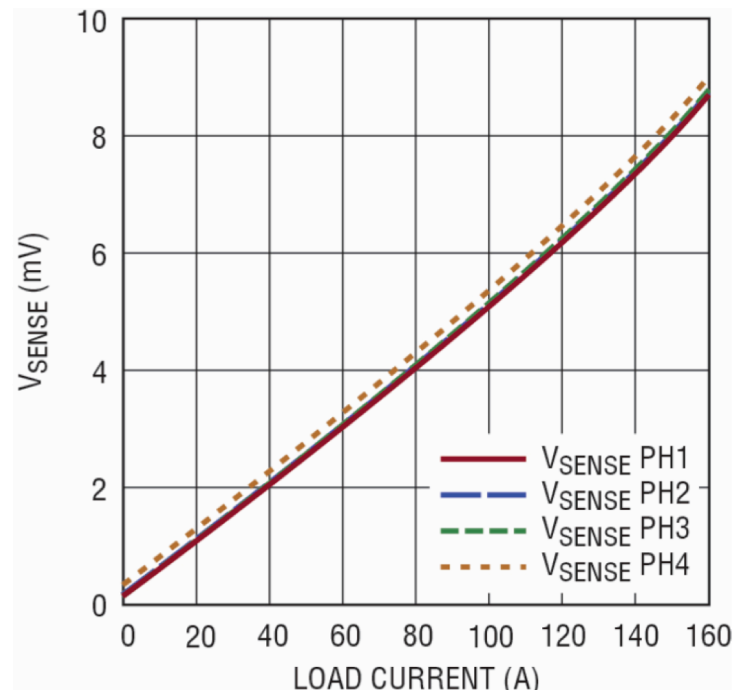

Transient

### Response and Line Feedforward Compensation

The LTC7851s onboard error amplifiers are true operational amplifiers that have high bandwidth, high DC gain, low offset and low output impedance. Their bandwidth, when combined with high switching frequencies and low-value inductors, allows the compensation network to be optimized for high control loop crossover frequencies and excellent step-load transient response. In addition, the LTC7851 achieves outstanding line transient response using a feedforward correction scheme which instantaneously adjusts the duty cycle to compensate for changes in input voltage, significantly reducing output overshoot and undershoot. It has the added advantage of making the DC loop gain independent of input voltage. Figure 4 shows how a 40A load step with a 12V input voltage has only 72mV peak to peak output voltage disturbance.

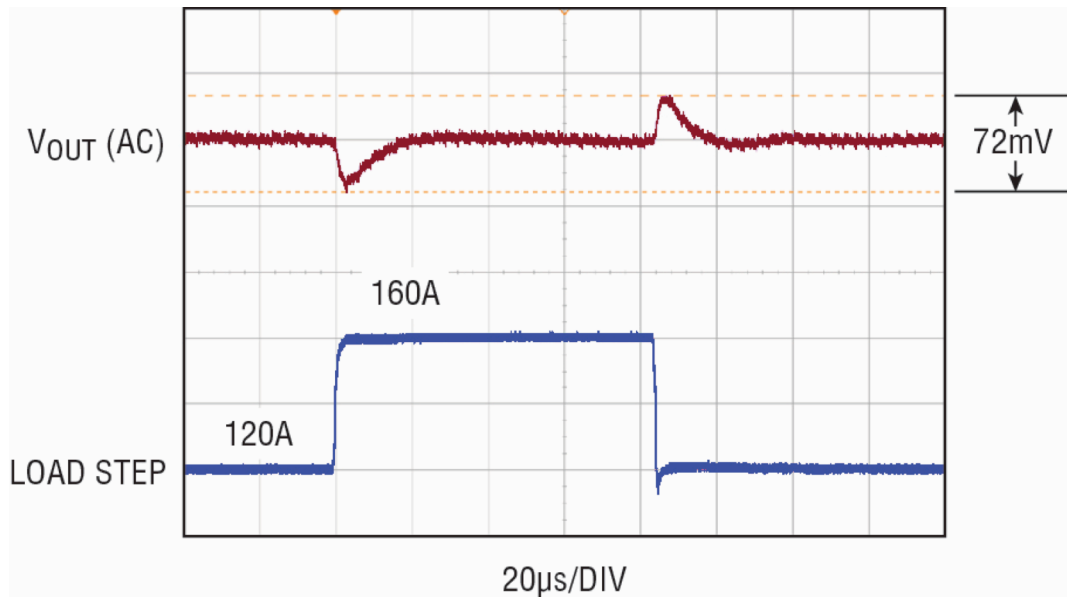

Figure 4. Transient Response To a 40A Step Load for the Circuit in Figure 1

### Multiphase Operation

Up to twelve phases can be daisy chained to run simultaneously out-of-phase with respect to each other. A multiphase power supply reduces the amount of ripple current in both the input and output capacitors, which significantly reduces the EMI and filtering required when compared to a single phase alternative. The RMS input ripple current is divided by, and the effective ripple frequency is multiplied by, the total number of phases used. The output ripple amplitude is also reduced by the number of phases implemented. Figure 5 shows how easy it is to hook up multiple devices for 3-, 4-, 8- or 12-phase operation.

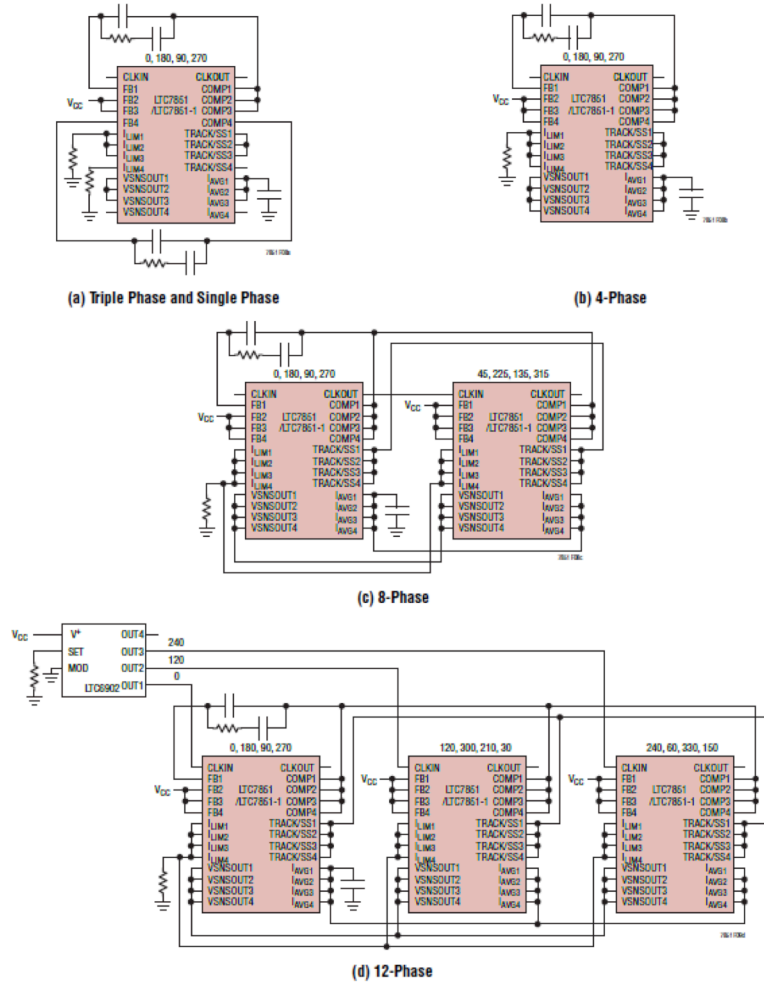

Figure 5. LTC7851 Multiple Phase Configurations

When the LTC7851/-1 is used in a single output, multiphase application, the slave error amplifiers must be disabled by connecting their FB pins to  $V_{CC}$ . All current limits should be set to the same value using only one resistor to SGND. The CLKOUT signal can be connected to the CLKIN pin of the following LTC7851/-1 stage to line up both the frequency and the phase of the entire system.

## Conclusion

As router and switch designs become more complex, power system designers can now create designs at different power levels using a single DC/DC controller that scales across multiple platforms. The ability to select from one to twelve phases, at up to 40A/phase along with using DrMOS or power blocks in the power train, allows the LTC7851/-1 to provide a smart highly flexible solution for the most demanding communication and networking products.