



16-Channel/Dual 8-Channel JFET Analog Multiplexers (Overvoltage Protected)

MUX-16/MUX-28

FEATURES

- JFET Switches Rather Than CMOS
- Highly Resistant To Static Discharge Damage
- No SCR Latch-up Problems
- Low "ON" Resistance — 290Ω Typical
- Low Leakage Current
- Digital Inputs Compatible With TTL and CMOS
- Break-Before-Make Action
- 125° C Temperature-Tested Dice Available
- Overvoltage Protected
- Supply Loss Protection
- MUX-16 Pin Compatible With DG506, HI-506A, AD7506
- MUX-28 Pin Compatible With DG507, HI-507A, AD7507
- Available in Die Form

ORDERING INFORMATION

25°C RESISTANCE	PACKAGE			OPERATING TEMPERATURE RANGE
	CERDIP 28-PIN	LCC 28-CONTACT	PLASTIC 28-PIN	
290Ω	MUX16AT*	-	-	MIL
290Ω	MUX16ET	-	-	IND
400Ω	MUX16BT*	MUX16BTC/883	-	MIL
400Ω	MUX16FT	-	MUX16FP	XIND
400Ω	-	-	MUX16FPC	XIND
290Ω	MUX28AT*	-	-	MIL
290Ω	MUX28ET	-	-	IND
400Ω	MUX28BT*	MUX28BTC/883	-	MIL
400Ω	MUX28FT	-	MUX28FP	XIND
400Ω	-	-	MUX28FPC	XIND

* For devices processed in total compliance to MIL-STD-883, add /883 after part number. Consult factory for 883 data sheet.

† Burn-in is available on commercial and industrial temperature range parts in CerDIP, plastic DIP, and TO-can packages.

GENERAL DESCRIPTION

The MUX-16 is a monolithic 16-channel analog multiplexer which connects a single output to 1 of the 16 analog inputs depending upon the state of a 4-bit binary address. Disconnection of the output is provided by a logical "0" at the ENABLE input, thereby providing a package selection function.

The MUX-28 is a monolithic 8-channel differential analog multiplexer configured in a double pole, 8-position (plus OFF) electronic switch array. A 3-bit binary input address connects a pair of independent analog inputs from each 8-channel input section to the corresponding pair of independent analog outputs. Disconnection of both inputs is provided by a logical "0" at the ENABLE input, thereby offering a package select function.

Fabricated with Precision Monolithics' high performance Bipolar-JFET technology, these devices offer low, constant "ON" resistance. Performance advantages include low leakage currents and fast settling time with low crosstalk to satisfy a wide variety of applications. These multiplexers do not suffer from latch-up or static discharge blow-out problems associated with similar CMOS parts. The digital inputs are designed to operate from both TTL and CMOS levels while always providing a definite break-before-make action without the need for external pull-up resistors. For single 8-channel and dual 4-channel models, refer to the MUX-08/MUX-24 data sheet.

FUNCTIONAL DIAGRAMS

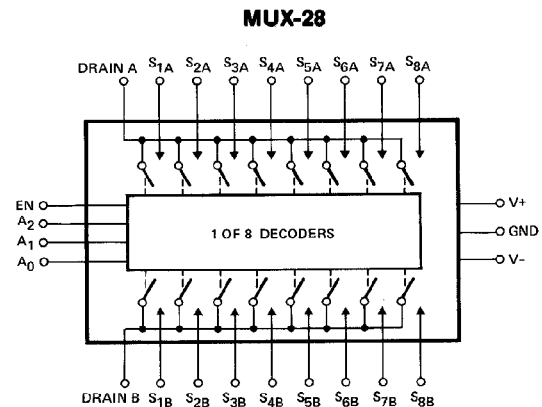
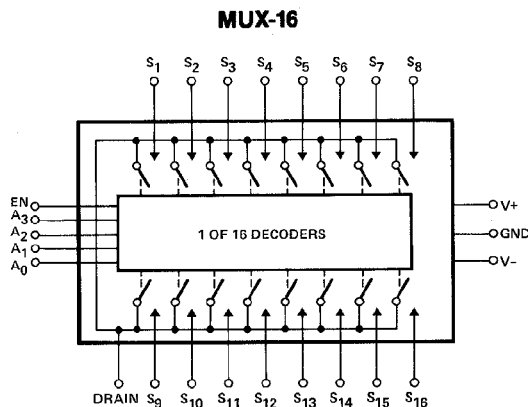

REV. A

Information furnished by Analog Devices is believed to be accurate and reliable. However, no responsibility is assumed by Analog Devices for its use, nor for any infringements of patents or other rights of third parties which may result from its use. No license is granted by implication or otherwise under any patent or patent rights of Analog Devices.

One Technology Way, P.O. Box 9106, Norwood, MA 02062-9106, U.S.A.
 Tel: 617/329-4700 Fax: 617/326-8703 Twx: 710/394-6577
 Telex: 924491 Cable: ANALOG NORWOODMASS

MUX-16/MUX-28

PIN CONNECTIONS & TRUTH TABLES

MUX-16
28-PIN PLASTIC DIP (P-Suffix)
28-PIN CERDIP (T-Suffix)

MUX-28

MUX-16BTC/883
LCC (TC-Suffix)
PLCC (PC-Suffix)

MUX-16

A ₃	A ₂	A ₁	A ₀	EN	CHANNEL	A ₃	A ₂	A ₁	A ₀	EN	CHANNEL
X	X	X	X	L	NONE	H	L	L	L	H	9
L	L	L	L	H	1	H	L	L	H	H	10
L	L	L	H	H	2	H	L	H	L	H	11
L	L	H	L	H	3	H	L	H	H	H	12
L	L	H	H	H	4	H	H	L	L	H	13
L	H	L	L	H	5	H	H	L	H	H	14
L	H	L	H	H	6	H	H	H	L	H	15
L	H	H	L	H	7	H	H	H	H	H	16
L	H	H	H	H	8						

MUX-28

A ₂	A ₁	A ₀	EN	CHANNEL PAIR
X	X	X	L	NONE
L	L	L	H	1
L	L	H	H	2
L	H	L	H	3
L	H	H	H	4
H	L	L	H	5
H	L	H	H	6
H	H	L	H	7
H	H	H	H	8

ABSOLUTE MAXIMUM RATINGS (Note 1)

Operating Temperature Range,
 MUX-16/28-AT, BT, BTC -55°C to +125°C
 MUX-16/28-ET -25°C to +85°C
 MUX-16/28-FP, FPC, FT -40°C to +85°C
 Junction Temperature (T_J) -65°C to +150°C
 Storage Temperature Range -65°C to +150°C
 Lead Temperature (Soldering, 60 sec) 300°C
 Maximum Junction Temperature 150°C
 V₊ Supply to V₋ Supply 36V
 Logic Input Voltage (V₋ or -4V) to V₊ Supply
 Analog Input Voltage V₋ Supply -20V to V₊ Supply +20V

Maximum Current Through Any Pin 25mA

PACKAGE TYPE	e _{JA} (Note 2)	e _{Jc}	UNITS
28-Pin Hermetic DIP (T)	55	15	°C/W
28-Pin Plastic DIP (P)	56	30	°C/W
28-Contact LCC (TC)	86	35	°C/W
28-Contact PLCC (PC)	70	33	°C/W

- NOTES:
 1. Ratings apply to both DICE and packaged parts, unless otherwise noted.
 2. e_{JA} is specified for worst case mounting conditions, i.e., e_{JA} is specified for device in socket for CerDIP, P-DIP, and LCC packages; e_{Jc} is specified for device soldered to printed circuit board for PLCC package.

ELECTRICAL CHARACTERISTICS at V_S = ±15V and T_A = 25°C, unless otherwise noted.

PARAMETER	SYMBOL	CONDITIONS	MUX-16A/E MUX-28A/E			MUX-16B/F MUX-28B/F			UNITS
			MIN	TYP	MAX	MIN	TYP	MAX	
"ON" Resistance	R _{ON}	V _S ≤ 10V, I _S ≤ 200μA	—	290	380	—	400	580	Ω
ΔR _{ON} With Applied Voltage	ΔR _{ON}	-10V ≤ V _S ≤ 10V, I _S = 200μA	—	1.5	5	—	1.5	5	%
R _{ON} Match Between Switches	R _{ON} Match	V _S = 0V, I _S = 200μA	—	7	15	—	9	20	%
Analog Voltage Range	V _A	{Note 6}	+10	+11	—	+10	+11	—	V
			-10	-15	—	-10	-15	—	
Source Current (Switch "OFF")	I _S (OFF)	V _S = 10V, V _D = -10V (Note 1)	—	0.01	1	—	0.01	2	nA
Drain Current (Switch "OFF")	I _D (OFF)	V _S = 10V, V _D = -10V (Note 1)	MUX-16	—	0.2	1	—	0.2	2
			MUX-28	—	0.1	1	—	0.1	2
Leakage Current (Switch "ON")	I _D (ON) + I _S (ON)	V _D = 10V (Note 1)	MUX-16	—	0.2	1	—	0.2	2
			MUX-28	—	0.1	1	—	0.1	2
Digital Input Current	I _{IN}	V _{IN} = 0.4V to 15V	—	1	10	—	1	10	μA

MUX-16/MUX-28

ELECTRICAL CHARACTERISTICS at $V_S = \pm 15V$ and $T_A = +25^\circ C$, unless otherwise noted. *Continued*

PARAMETER	SYMBOL	CONDITIONS	MUX-16A/E MUX-28A/E			MUX-16B/F MUX-28B/F			UNITS	
			MIN	TYP	MAX	MIN	TYP	MAX		
Digital "0" Enable Current	$I_{INL(EN)}$	$V_{EN} = 0.4V$	-	4	10	-	4	10	μA	
Digital Input Capacitance	C_{DIG}		-	3	-	-	3	-	pF	
Switching Time (t_{TRAN})	t_{PHL}	(Notes 2,5) Figure 1	-	1.4	2.0	-	1.8	2.5	μs	
	t_{PLH}	(Test Circuits)	-	1.2	1.8	-	1.6	2.2		
Output Settling Time	t_s	10V Step to 0.10%	-	2.6	-	-	2.7	-	μs	
		10V Step to 0.05%	-	3.2	-	-	3.4	-		
		10V Step to 0.02%	-	4.0	-	-	7.2	-		
Break-Before-Make Delay	t_{OPEN}	Figure 3	-	0.7	-	-	1	-	μs	
Enable Delay "ON"	$t_{ON(EN)}$	(Note 5) Figure 2 (Test Circuits)	-	1	2	-	1.2	2.5	μs	
Enable Delay "OFF"	$t_{OFF(EN)}$	(Note 5) Figure 2 (Test Circuits)	MUX-16	-	0.25	0.5	-	0.25	0.5	μs
			MUX-28	-	0.25	0.5	-	0.25	0.6	
"OFF" Isolation	ISO_{OFF}	(Note 4) Figure 4 (Test Circuits)	-	66	-	-	66	-	dB	
Crosstalk	CT	(Note 3) Figure 5 (Test Circuits)	-	75	-	-	75	-	dB	
Source Capacitance	$C_S(OFF)$	Switch "OFF," $V_S = 0V, V_D = 0V$	-	2.5	-	-	2.5	-	pF	
Drain Capacitance	$C_D(OFF)$	Switch "OFF," $V_S = 0V, V_D = 0V$	MUX-16	-	13	-	-	13	-	pF
			MUX-28	-	8	-	-	8	-	
Input to Output Capacitance	$C_{DS(OFF)}$	(Note 4)	-	0.15	-	-	0.15	-	pF	
Positive Supply Current (All Digital Inputs Logic "0" or "1")	I_+	$V_+ = 15V$	MUX-16	-	15	19	-	9	19	mA
			MUX-28	-	15	19	-	8	19	
			MUX-16	-	12	-	-	8	-	
			MUX-28	-	12	-	-	7	-	
Negative Supply Current (All Digital Inputs Logic "0" or "1")	I_-	$V_- = -15V$	MUX-16	-	5	7	-	3.5	7	μA
			MUX-28	-	5	7	-	3	7	
			MUX-16	-	4	-	-	3	-	
			MUX-28	-	4	-	-	2.5	-	

NOTES:

- Conditions applied to leakage tests insure worst case leakages.
- $R_L = 10M\Omega, C_L = 10pF$.
- Crosstalk is measured by driving channel 8 (8B*) with channel 7 (7B*) ON.
 $R_L = 1M\Omega, C_L = 10pF, V_S = 5V$ RMS, $f = 500kHz$.
- "OFF" isolation is measured by driving channel 8 (8B) with ALL channels OFF.
 $R_L = 1k\Omega, C_L = 10pF, V_S = 5V$ RMS, $f = 500kHz$. C_{DS} is computed from the OFF isolation measurement.
- Sample tested.
- Guaranteed by leakage current and R_{ON} tests.

ELECTRICAL CHARACTERISTICS at $V_S = \pm 15V, -55^\circ C \leq T_A \leq +125^\circ C$ for MUX-16AT/BT/BTC and MUX-28AT/BT/BTC; $-25^\circ C \leq T_A \leq +85^\circ C$ for MUX-16ET and MUX-28ET; $-40^\circ C \leq T_A \leq +85^\circ C$ for MUX-16 FT/FP/FPC and MUX-28FT/FP/FPC, unless otherwise noted.

PARAMETER	SYMBOL	CONDITIONS	MUX-16A/E MUX-28A/E			MUX-16B/F MUX-28B/F			UNITS
			MIN	TYP	MAX	MIN	TYP	MAX	
"ON" Resistance	R_{ON}	$V_S \leq 10, I_S \leq 200\mu A$	-	-	500	-	-	800	Ω
ΔR_{ON} With Applied Voltage	ΔR_{ON}	$-10V \leq V_S \leq 10V, I_S = 200\mu A$	-	2	-	-	5.5	-	%
R_{ON} Match Between Switches	R_{ON} Match	$V_S = 0V, I_S = 200\mu A$	-	10	-	-	15	-	%
Analog Voltage Range	V_A	(Note 6)	+10 -10	+11 -15	-	+10 -10	+11 -15	-	V
Source Current (Switch "OFF")	$I_S(OFF)$	$V_S = 10V, V_D = -10V$ (Note 1)	-	-	25	-	-	50	nA
Drain Current (Switch "OFF")	$I_D(OFF)$	$V_S = 10V, V_D = -10V$ (Note 1)	-	-	75	-	-	250	nA
Leakage Current (Switch "ON")	$I_D(ON)$	$V_D = 10V$ (Note 1)	-	-	75	-	-	250	nA
	$+I_S(ON)$								
Digital "1" Input Voltage	V_{INH}	(Note 6)	2	-	-	2	-	-	V
Digital "0" Input Voltage	V_{INL}	(Note 6)	-	-	0.7	-	-	0.7	V
Digital Input Current	I_{IN}	$V_{IN} = 0.4V$ to 15V	-	-	20	-	-	20	μA
Digital "0" Enable Current	$I_{INL(EN)}$	$V_{EN} = 0.4V$	-	-	20	-	-	20	μA
Positive Supply Current	I_+	All Digital Inputs Logic "0" or "1"	-	-	24	-	-	24	mA
Negative Supply Current	I_-	All Digital Inputs Logic "0" or "1"	-	-	8.2	-	-	8.2	mA

MUX-16/MUX-28

DICE CHARACTERISTICS (125°C TESTED DICE AVAILABLE)

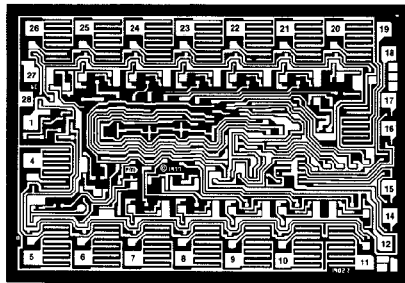

MUX-16

MUX-28

**DIE SIZE 0.110 × 0.076 inch, 8360 sq. mils
(2.794 × 1.930 mm, 5392 sq. mm)**

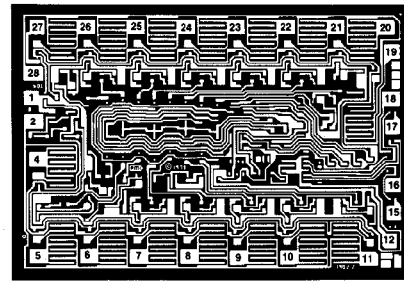

- 1. POSITIVE SUPPLY
- 4. SOURCE 16 (S16)
- 5. SOURCE 15 (S15)
- 6. SOURCE 14 (S14)
- 7. SOURCE 13 (S13)
- 8. SOURCE 12 (S12)
- 9. SOURCE 11 (S11)
- 10. SOURCE 10 (S10)
- 11. SOURCE 9 (S9)
- 12. GROUND
- 14. ADDRESS BIT 3 (A3)
- 15. ADDRESS BIT 2 (A2)
- 16. ADDRESS BIT 1 (A1)
- 17. ADDRESS BIT 0 (A0)
- 18. ENABLE
- 19. SOURCE 1 (S1)
- 20. SOURCE 2 (S2)
- 21. SOURCE 3 (S3)
- 22. SOURCE 4 (S4)
- 23. SOURCE 5 (S5)
- 24. SOURCE 6 (S6)
- 25. SOURCE 7 (S7)
- 26. SOURCE 8 (S8)
- 27. NEGATIVE SUPPLY (SUBSTRATE)
- 28. DRAIN

- 1. POSITIVE SUPPLY
- 2. DRAIN B
- 4. SOURCE 8 (S8B)
- 5. SOURCE 7 (S7B)
- 6. SOURCE 6 (S6B)
- 7. SOURCE 5 (S5B)
- 8. SOURCE 4 (S4B)
- 9. SOURCE 3 (S3B)
- 10. SOURCE 2 (S2B)
- 11. SOURCE 1 (S1B)
- 12. GROUND
- 15. ADDRESS BIT 2 (A2)
- 16. ADDRESS BIT 1 (A1)
- 17. ADDRESS BIT 0 (A0)
- 18. ENABLE
- 19. SOURCE 1 (S1A)
- 20. SOURCE 2 (S2A)
- 21. SOURCE 3 (S3A)
- 22. SOURCE 4 (S4A)
- 23. SOURCE 5 (S5A)
- 24. SOURCE 6 (S6A)
- 25. SOURCE 7 (S7A)
- 26. SOURCE 8 (S8A)
- 27. NEGATIVE SUPPLY (SUBSTRATE)
- 28. DRAIN A

WAFER TEST LIMITS at $V_+ = 15V$, $V_- = -15V$, $T_A = 25^\circ C$ for MUX-16/28 N and G, $T_A = 125^\circ C$ for MUX-16/28 NT and GT, unless otherwise noted.

PARAMETER	SYMBOL	CONDITIONS	MUX-16/ MUX-28NT	MUX-16/ MUX-28N	MUX-16/ MUX-28GT	MUX-16/ MUX-28G	UNITS
			LIMIT	LIMIT	LIMIT	LIMIT	
"ON" Resistance	R_{ON}	$V_S = 0V$, $I_S = 200\mu A$	540	380	800	580	Ω MAX
Digital "1" Input Voltage	V_{INH}		2	2	2	2	V MIN
Digital "0" Input Voltage	V_{INL}		0.8	0.8	0.8	0.8	V MAX
Digital "0" Input Current	I_{INL}	$V_{IN} = 0.4V$	20	10	20	10	μA MAX
Digital "0" Enable Current	$I_{INL(EN)}$	$V_{EN} = 0.4V$	20	10	20	10	μA MAX
Positive Supply Current (All Digital Inputs Logic "0")	I_+		24	19	24	19	mA MAX
Negative Supply Current (All Digital Inputs Logic "0")	I_-		8.2	7	8.2	7	mA MAX
Analog Input Range	V_A	(Note 2)	± 10	± 10	± 10	± 10	V MIN

NOTE:

Electrical tests are performed at wafer probe to the limits shown. Due to variations in assembly methods and normal yield loss, yield after packaging is not guaranteed for standard product dice. Consult factory to negotiate specifications based on dice lot qualification through sample lot assembly and testing.

TYPICAL ELECTRICAL CHARACTERISTICS at $V_+ = 15V$, $V_- = -15V$ and $T_A = 25^\circ C$ for MUX-16/28 N and G, $T_A = 125^\circ C$ for MUX-16/28 NT and GT, unless otherwise noted.

PARAMETER	SYMBOL	CONDITIONS	MUX-16/ MUX-28NT	MUX-16/ MUX-28N	MUX-16/ MUX-28GT	MUX-16/ MUX-28G	UNITS
			TYPICAL	TYPICAL	TYPICAL	TYPICAL	
Switching Time (t_{TRAN})	t_{PHL}	(Note 1) Figure 1	2	1	2.6	1.5	μs
	t_{PLH}		1.8	0.9	2.4	1.4	
Output Settling Time	t_S	10V Step to 0.1% (Note 1)	2.5	1.5	2.9	1.9	μs
Break-Before-Make Delay	t_{OPEN}	(Note 1) Figure 3 (Test Circuits)	0.8	0.8	1	1	μs
Crosstalk	CT	(Note 1) Figure 5 (Test Circuits)	70	70	70	70	dB
ΔR_{ON} With Applied Voltage	ΔR_{ON}	$-10V \leq V_S \leq 10V$, $I_S = 200\mu A$	1.5	1.5	1.5	1.5	%
Leakage Current (Switch "ON")	$I_{D(ON)}$	$V_D = 10V$ (Note 1)	20	0.2	20	0.2	nA
Analog Input Range	V_A	(Note 2)	+11	+11	+11	+11	V
			-15	-15	-15	-15	

NOTES:

- 1. The data shown is extrapolated from measurements made on the packaged devices.
- 2. Guaranteed by R_{ON} and leakage current tests.

MUX-16/MUX-28

TYPICAL PERFORMANCE CHARACTERISTICS (apply to all grades, unless otherwise noted.)

"ON" RESISTANCE (R_{ON}) vs ANALOG VOLTAGE (V_A)

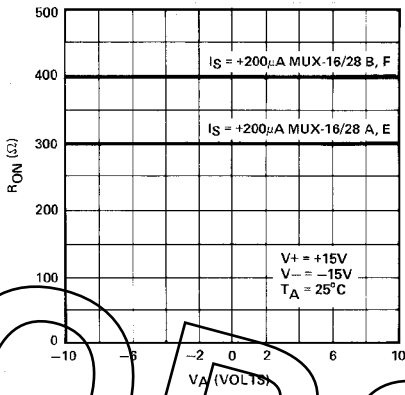

R_{ON} vs SWITCH VOLTAGE (V_{SD})

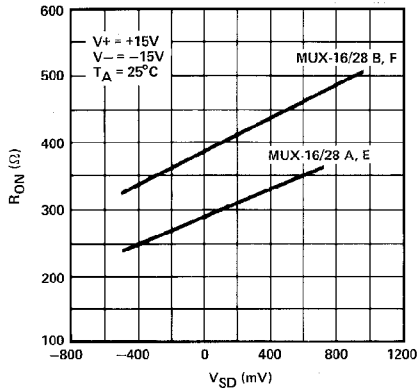

R_{ON} vs SWITCH CURRENT (I_S)

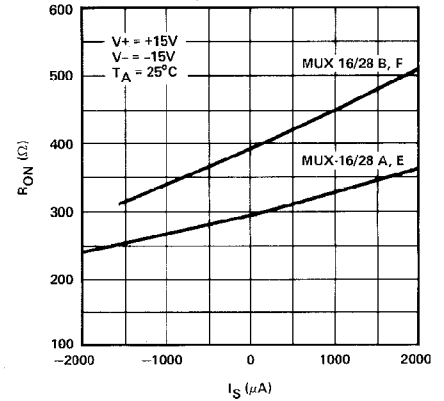

R_{ON} vs TEMPERATURE (T)

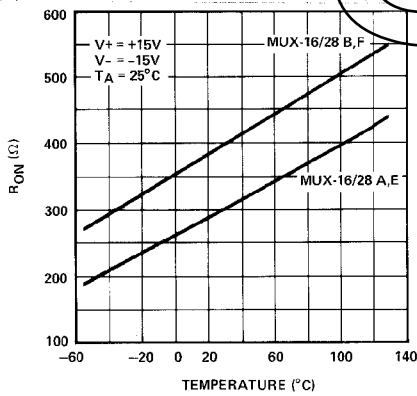

MUX-16 SWITCH LEAKAGE CURRENTS vs ANALOG INPUT VOLTAGE (V_A)

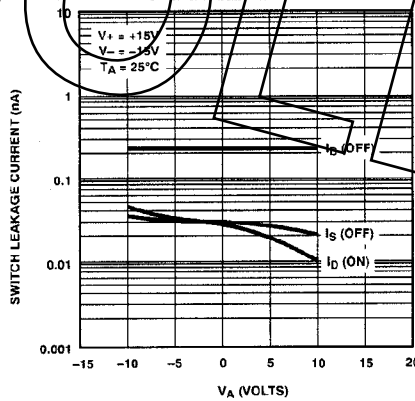

MUX-28 SWITCH LEAKAGE CURRENTS vs ANALOG INPUT VOLTAGE (V_A)

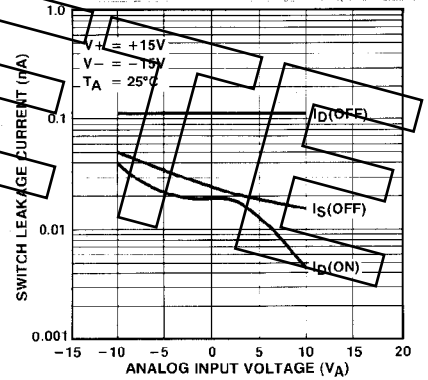

SWITCH LEAKAGE CURRENTS vs TEMPERATURE

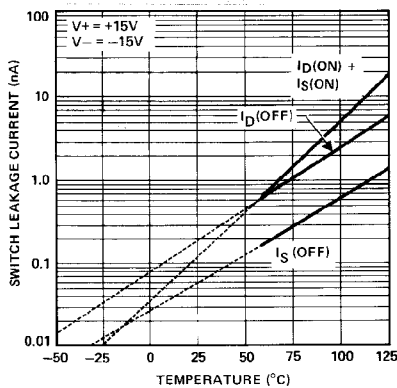

SUPPLY CURRENTS vs TEMPERATURE (T)

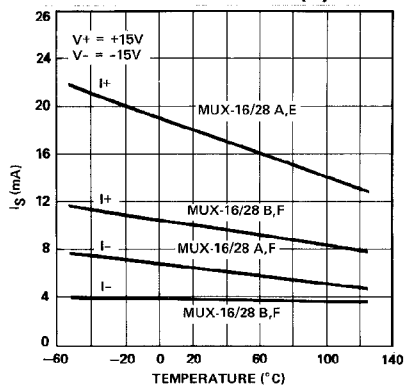

SWITCH CAPACITANCES vs ANALOG INPUT VOLTAGE (V_A)

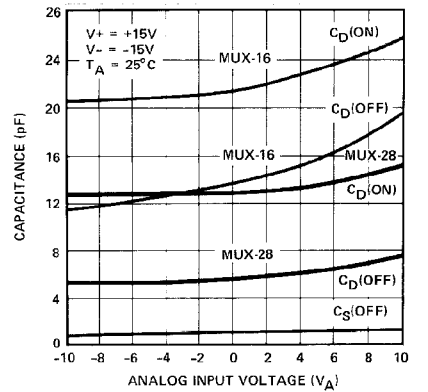

MUX-16/MUX-28

TYPICAL PERFORMANCE CHARACTERISTICS (apply to all grades, unless otherwise noted.)

**MUX-16
OFF PERFORMANCE OF
CHANNEL 8**

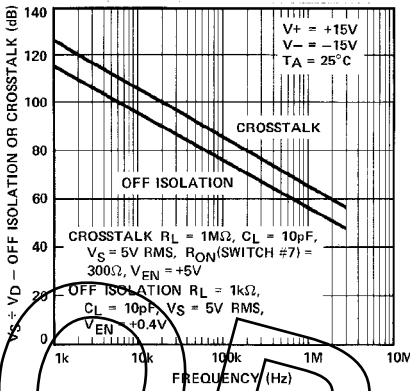

**MUX-28
OFF PERFORMANCE OF
CHANNEL 8**

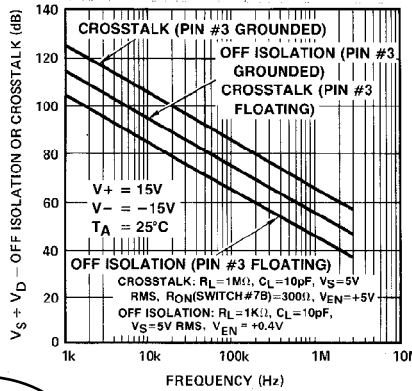

DIGITAL INPUT BIAS CURRENTS vs TEMPERATURE (T)

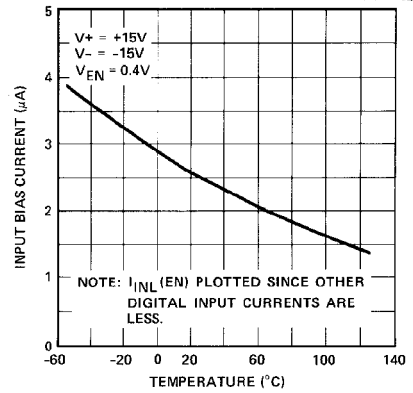

MUX-16 DYNAMIC CHARACTERISTIC CURVES

SMALL-SIGNAL SWITCHING

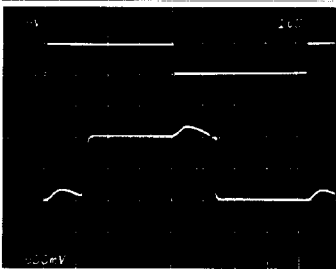

RL = 1MΩ, CL = 10pF, V1 = -500mV, V16 = +500mV

SMALL-SIGNAL SWITCHING WITH FILTERING

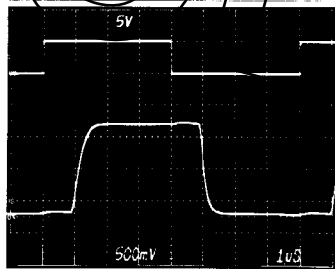

RL = 1MΩ, CL = 500pF, V1 = -500mV, V16 = +500mV

SMALL-SIGNAL SWITCHING WITH 2μs SAMPLE TIME

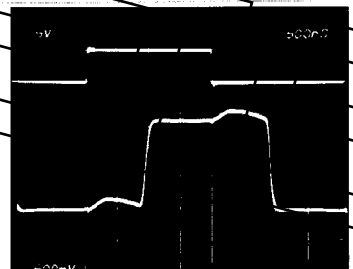

RL = 1MΩ, CL = 10pF, V1 = -700mV, V16 = +700mV

SMALL-SIGNAL SWITCHING WITH FILTERING AND 2μs SAMPLE TIME

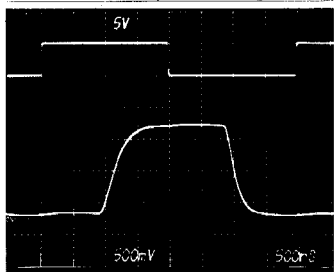

RL = 1MΩ, CL = 500pF, V1 = -700mV, V16 = +700mV

BREAK-BEFORE-MAKE SWITCHING

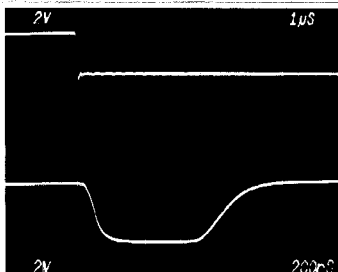

RL = 1kΩ, CL = 10pF, V1 = V16 = +10V

LARGE-SIGNAL SWITCHING

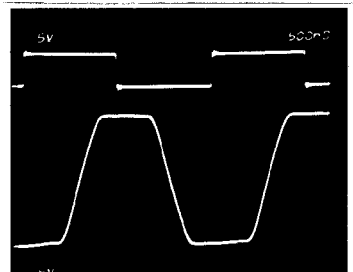

RL = 1MΩ, CL = 10pF, V1 = -10V, V16 = +10V

NOTE:

Top Waveforms: Digital Input 5V/Div
Bottom Waveforms: Multiplexer Output (V_D)

MUX-28 DYNAMIC CHARACTERISTIC CURVES

SMALL-SIGNAL SWITCHING

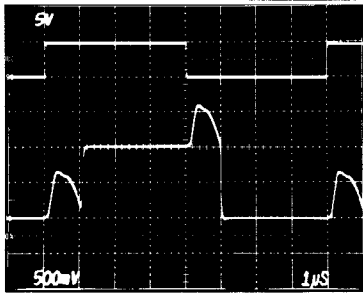

$R_L = 1M\Omega, C_L = 10pF, V_1 = -500mV, V_8 = +500mV$

SMALL-SIGNAL SWITCHING WITH FILTERING



$R_L = 1M\Omega, C_L = 500pF, V_1 = -500mV, V_8 = +500mV$

SMALL-SIGNAL SWITCHING WITH 2µs SAMPLE TIME

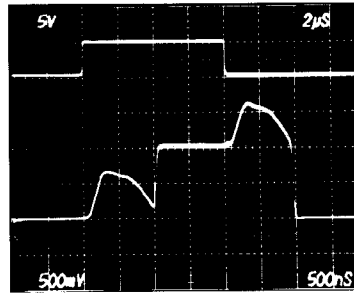

$R_L = 1M\Omega, C_L = 10pF, V_1 = -700mV, V_8 = +700mV$

SMALL-SIGNAL SWITCHING WITH FILTERING AND 2.5µs SAMPLE TIME

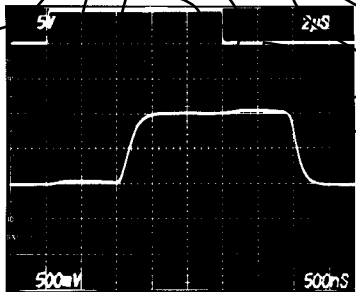

$R_L = 1M\Omega, C_L = 500pF, V_1 = -700mV, V_8 = +700mV$

BREAK-BEFORE-MAKE SWITCHING

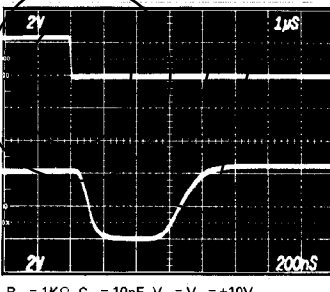

$R_L = 1K\Omega, C_L = 10pF, V_1 = V_8 = +10V$

LARGE-SIGNAL SWITCHING

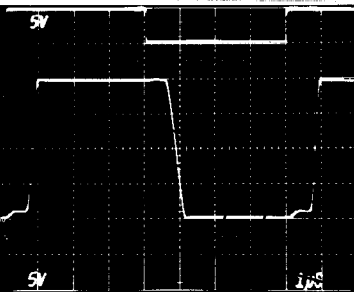

$R_L = 1M\Omega, C_L = 10pF, V_1 = -10V, V_8 = +10V$

NOTE:

Top Waveforms: Digital Input 5V/Div
Bottom Waveforms: Multiplexer Output (V_D)

TYPICAL PERFORMANCE CHARACTERISTICS (apply to all grades, unless otherwise noted.)

TRANSITION TIME vs TEMPERATURE

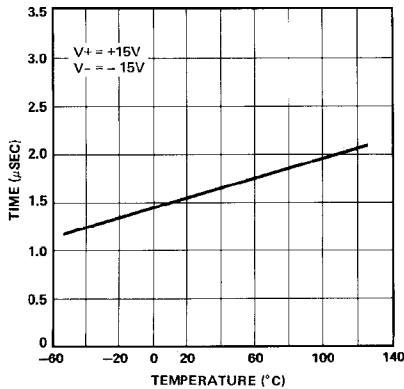

ENABLE DELAY TIME vs TEMPERATURE

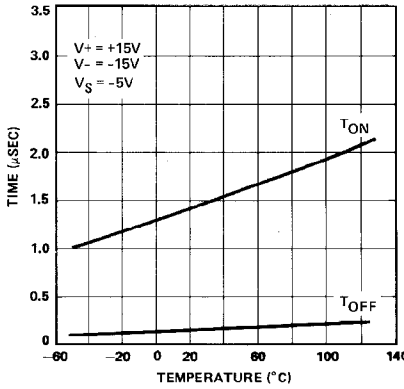

MUX-16/MUX-28

A.C. TEST CIRCUITS

TRANSITION TIME TEST CIRCUIT

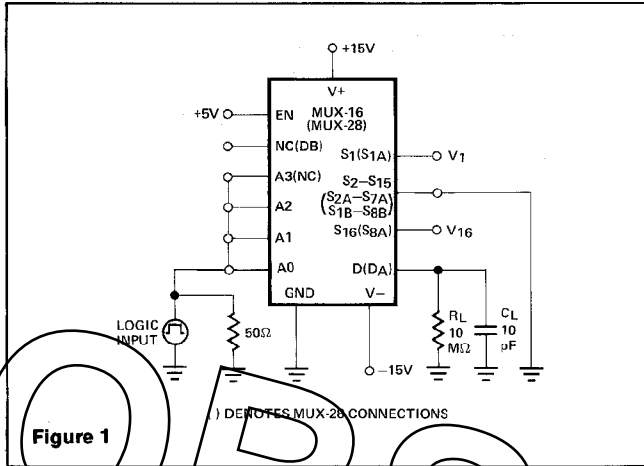

Figure 1

ENABLE DELAY TIME TEST CIRCUIT

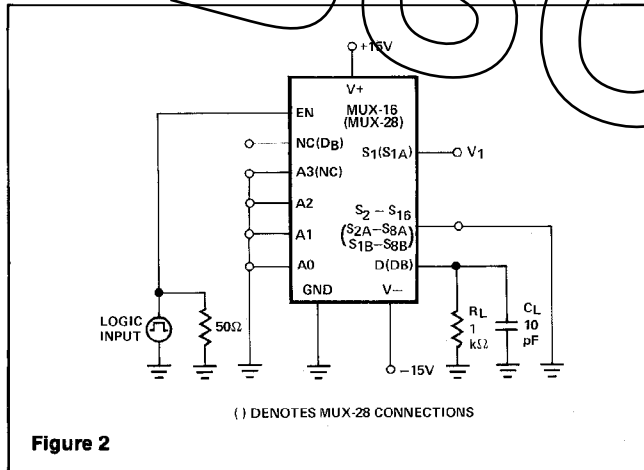

Figure 2

BREAK-BEFORE-MAKE TEST CIRCUIT

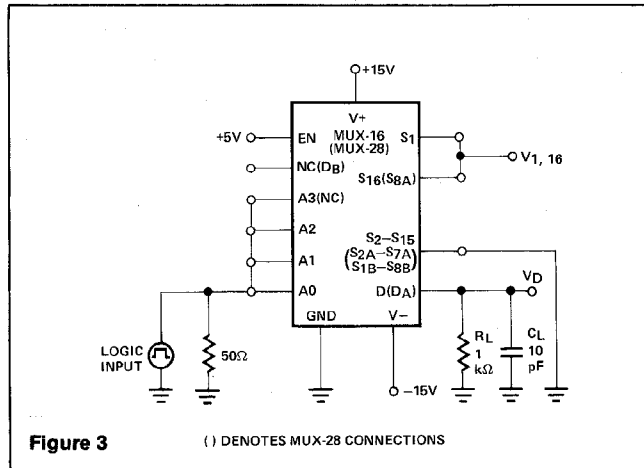
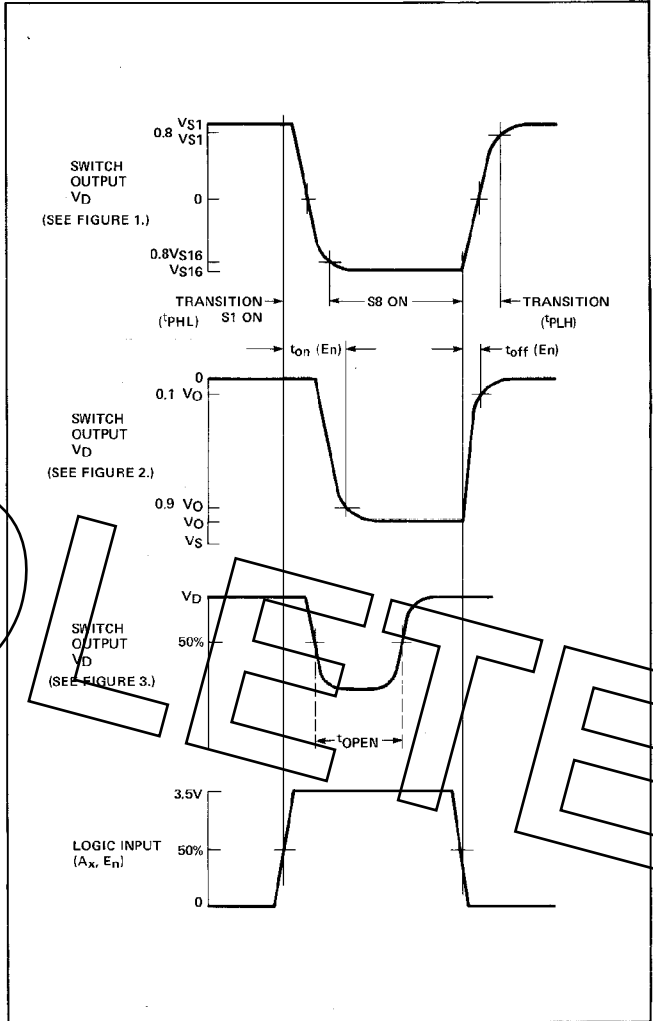

Figure 3

SWITCHING TIME WAVEFORMS



OFF ISOLATION TEST CIRCUIT

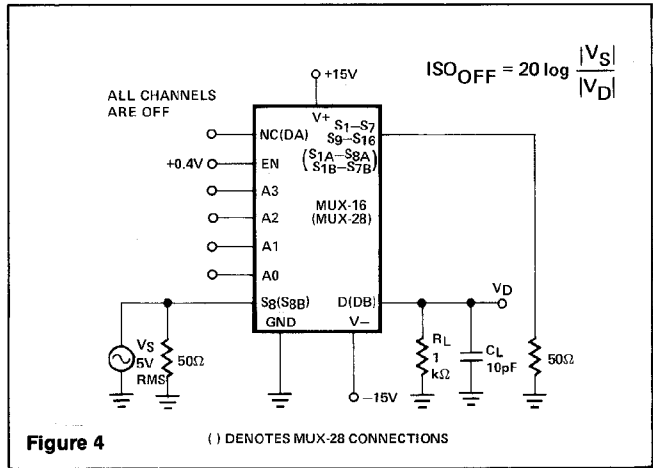

Figure 4

CROSSTALK MEASUREMENT CIRCUIT

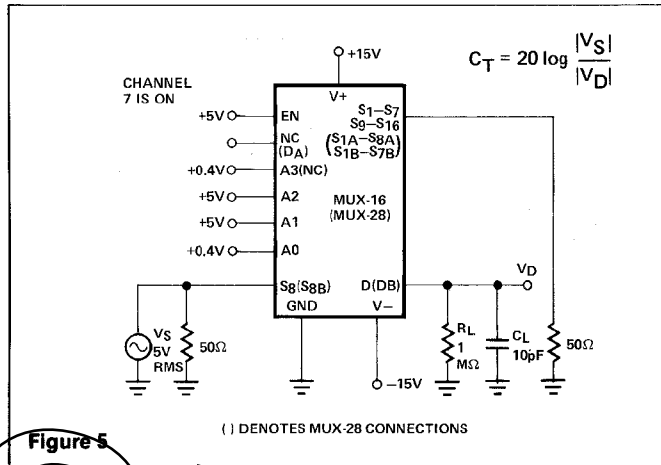
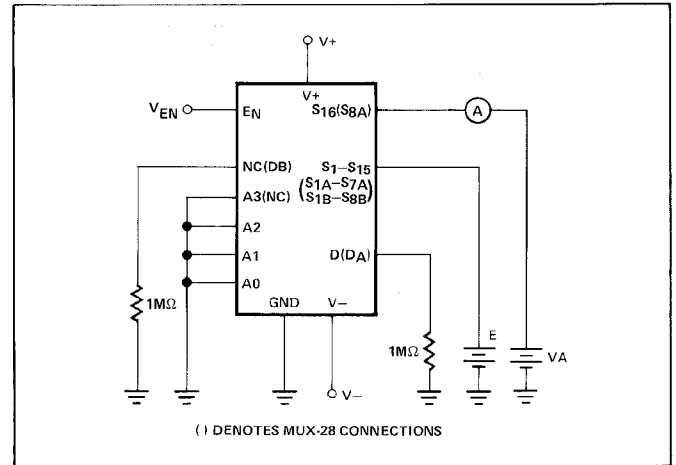

Figure 5

OVERVOLTAGE MEASUREMENT TEST CIRCUIT



APPLICATIONS INFORMATION

These analog multiplexers employ ion-implanted JFETs in a switch configuration designed to assure break-before-make (B.B.M.) action. The turn-off time is much faster than the turn-on time to guarantee B.B.M. over the full operating temperature and input voltage range. Fabricated with JFET processing rather than CMOS, special handling is not necessary to prevent damage to this multiplexer. Because the digital inputs only require a 2.0V logic "1" input level, power-consuming pullup resistors are not required for TTL compatibility to insure break-before-make switching as is most often the case with CMOS multiplexers. The digital inputs utilize PNP input transistors where input current is maximum at the logic "0" level and drops to that of a reverse-biased diode (about 10nA) as the input voltage is raised above $\approx 1.4V$.

The "ON" resistance, R_{ON} of the analog switches is constant over the wide input voltage range of $-15V$ to $+11V$ with $V_{SUPPLY} = \pm 15V$. The overvoltage and supply-loss V-I characteristics shown indicate typical performance when the multiplexer is subjected to abnormal signals. For normal operation, however, positive input voltages should be restricted to 11V (or 4V less than the positive supply). This assures that the V_{GS} of an OFF FET switch remains greater than its V_p , preventing that channel from being falsely turned ON.

When operating with negative input voltages, the gate-to-channel diode will be turned on if the voltage drop across an ON switch exceeds $-0.6V$. While this condition will cause an error in the output, it will not damage the switch. In lab tests, the multiplexer output has been loaded with a $0.01\mu F$ capacitor in the circuit of Figure 1. With $V_1 = -10V$ and $V_{16} = +10V$, the logic input was driven at a 1kHz rate. The positive-going slew rate was $0.3V/\mu Sec$ which is equivalent to a normal I_{DSS} of 3mA. The negative-going slew rate was $0.7V/\mu sec$ which is equivalent to a "reverse" I_{DSS} of 7mA. Note that when switch one (1) is first turned ON it has a drop of $-20V$ across its terminals. In spite of that fact, the current is limited to approximately twice its normal I_{DSS} .

OVERVOLTAGE V-I CHARACTERISTIC

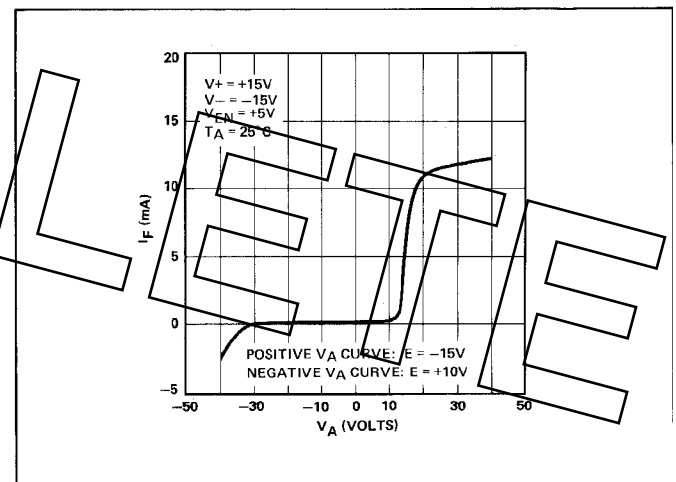

SUPPLY-LOSS V-I CHARACTERISTIC

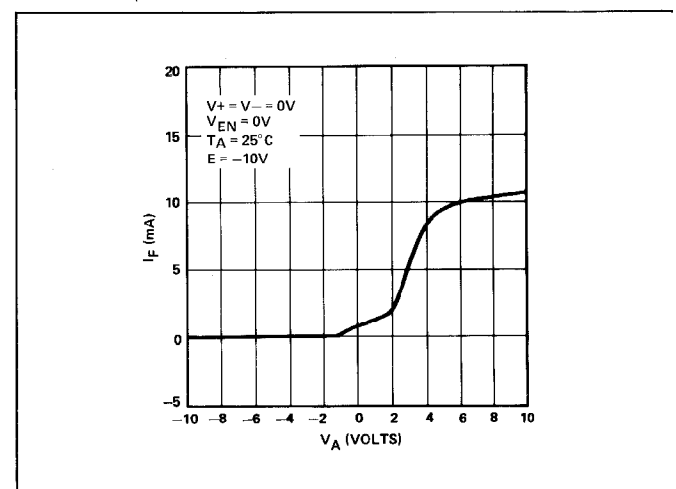

MUX-16/MUX-28

SIMPLIFIED SCHEMATIC (MUX-16)

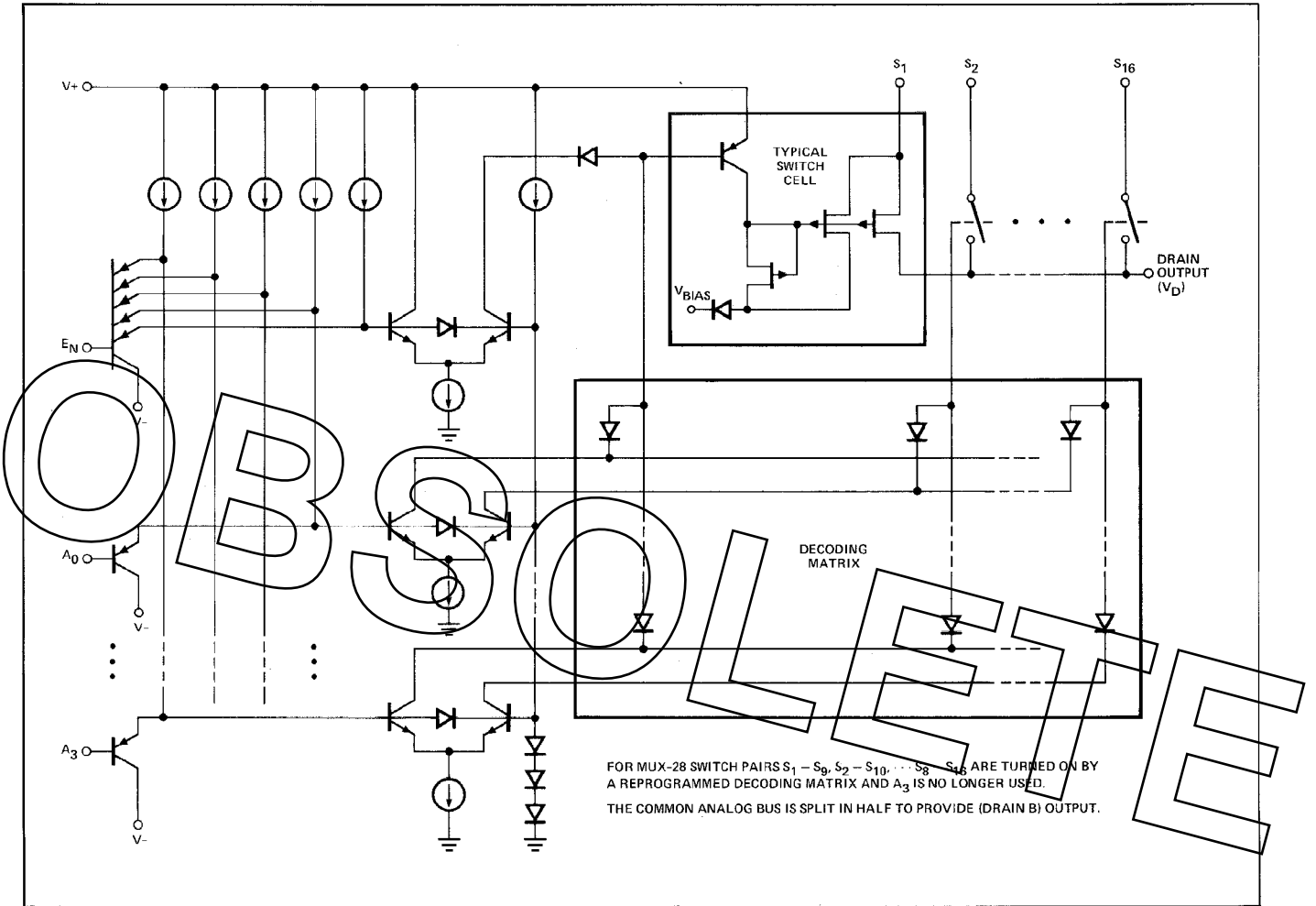

OBSOLETE

OBSOLETE