

| REVISION RECORD | | |
|-----------------|--|----------------|
| REV | DESCRIPTION | DATE |
| F | <ul style="list-style-type: none">PAGE 4, ADDED NOTE: ABSOLUTE MAXIMUM RATINGS ARE THOSE VALUES BEYOND WHICH THE LIFE OF A DEVICE MAY BE IMPAIRED. | 08/15/05 |
| G | <ul style="list-style-type: none">PAGE 5, CHANGED IN BOTH PARAGRAPHS 4.2, 4.3 IN CONJUNCTION TO 3.3 CHANGED TO 3.4 AND PARAGRAPH 4.3 CHANGED 3.1.1 TO 3.1 AND 3.2.1 TO 3.1.1 | 12/17/07 |
| H | <ul style="list-style-type: none">PAGE 4, PARAGRAPH 3.11.1 CHANGED VERBIAGE. | 04/30/08 |
| I | ADD MAXIMUM JUNCTION TEMPERATURE 150°C TO SECTION 3.4 CHANGED LINEAR TECH FOOTER TO ANALOG DEVICES INC. | 08/10/18 |
| J | TO CHANGE LINEAR TO ANALOG AND REMOVE SOURCE | 3/22/21 |

1.0 SCOPE:

- 1.1 This specification defines the performance and test requirements for a microcircuit processed to a space level manufacturing flow.

2.0 APPLICABLE DOCUMENTS:

- 2.1 Government Specifications and Standards: the following documents listed in the Department of Defense Index of Specifications and Standards, of the issue in effect on the date of solicitation, form a part of this specification to the extent specified herein.

SPECIFICATIONS:

| | |
|---------------|--|
| MIL-PRF-38535 | Integrated Circuits (Microcircuits) Manufacturing, General Specification for |
| MIL-STD-883 | Test Method and Procedures for Microcircuits |
| MIL-STD-1835 | Microcircuits Case Outlines |

- 2.2 Order of Precedence: In the event of a conflict between the documents referenced herein and the contents of this specification, the order of precedence shall be this specification, MIL-PRF-38535 and other referenced specifications.

3.0 REQUIREMENTS:

- 3.1 General Description: This specification details the requirements for the RH1021-7, Precision 7V Reference, processed to space level manufacturing flow.

- 3.2 Part Number:

3.2.1 OPTION 1 – RH1021BMH-7 (TO5 METAL CAN, 8 LEAD)

3.2.2 OPTION 2 – RH1021DMH-7 (TO5 METAL CAN, 8 LEAD)

- 3.3 Part Marking Includes:

- a. LTC Logo
- b. LTC Part Number (See Paragraph 3.2)
- c. Date Code
- d. Serial Number
- e. ESD Identifier per MIL-PRF-38535, Appendix A

3.4 The Absolute Maximum Ratings:

| | |
|---|-----------------|
| Input Voltage | 40V |
| Input-Output Voltage Differential | 35V |
| Output to Ground Voltage (Shunt mode Current Limit) | 10V |
| Output Short Circuit Duration | |
| $V_{IN} = 35V$ | 10 sec. |
| $V_{IN} = \leq 20V$ | Indefinite |
| Operating Temperature Range | -55°C to +125°C |
| Maximum Junction Temperature | 150°C |
| Storage Temperature Range | -65°C to +150°C |
| Lead Temperature (Soldering, 10 sec) | +300°C |

NOTE: Absolute maximum ratings are those values beyond which the life of a device may be impaired.

- 3.5 Electrostatic discharge sensitivity, ESDS, shall be Class 1.
- 3.6 Electrical Performance Characteristics: The electrical performance characteristics shall be as specified in Table I and **Table II**.
- 3.7 Electrical Test Requirements: Screening requirements shall be in accordance with 4.1 herein, MIL-STD-883, Method 5004, and as specified in **Table IV** herein.
- 3.8 Burn-In Requirement: Burn-in circuit is specified in Figure 4.
- 3.9 Delta Limit Requirement: Delta limit parameters are specified in **Table III** herein, are calculated after each burn-in, and the delta rejects are included in the PDA calculation.
- 3.10 Design, Construction, and Physical Dimensions: Detail design, construction, physical dimensions, and electrical requirements shall be specified herein.
- 3.10.1 Mechanical / Packaging Requirements: Case outlines and dimensions are in accordance with Figure 1.
- 3.10.2 Terminal Connections: The terminal connections shall be as specified in Figure 2.
- 3.10.3 Lead Material and Finish: The lead material and finish shall be Kovar with hot solder dip (Finish letter A) in accordance with MIL-PRF-38535.
- 3.11 Radiation Hardness Assurance (RHA):
- 3.11.1 The manufacturer shall perform a lot sample test as an internal process monitor for total dose radiation tolerance. The sample test is performed with MIL-STD-883 TM1019 Condition A as a guideline.
- 3.11.2 For guaranteed radiation performance to MIL-STD-883, Method 1019, total dose irradiation, the manufacturer will provide certified RAD testing and report through an independent test laboratory when required as a customer purchase order line item.

3.11.3 Total dose bias circuit is specified in Figure 3.

3.12 Wafer Lot Acceptance: Wafer lot acceptance shall be in accordance with MIL-PRF-38535, Appendix A, except for the following: Topside glassivation thickness shall be a minimum of 4KÅ.

3.13 Wafer Lot Acceptance Report: SEM is performed per MIL-STD-883, Method 2018 and copies of SEM photographs shall be supplied with the Wafer Lot Acceptance Report as part of a Space Data Pack when specified as a customer purchase order line item.

4.0 VERIFICATION (QUALITY ASSURANCE PROVISIONS)

4.1 Quality Assurance Provisions: Quality Assurance provisions shall be in accordance with MIL-PRF-38535. **Analog Devices** is a QML certified company and all Rad Hard candidates are assembled on qualified Class S manufacturing lines.

4.2 Sampling and Inspection: Sampling and Inspection shall be in accordance with MIL-STD-883, Method 5005 with QML allowed and TRB approved deviations in conjunction with paragraphs 3.1.1, 3.2.1, and 3.4 of the test method.

4.3 Screening: Screening requirements shall be in accordance with MIL-STD-883, Method 5004 with QML allowed and TRB approved deviations in conjunction with paragraphs 3.1, 3.1.1, and 3.4 of the test method. Electrical testing shall be as specified in **Table IV** herein.

4.3.1 Analysis of catastrophic (open/short) failures from burn-in will be conducted only when a lot fails the burn-in or re-burn-in PDA requirements.

4.4 Quality Conformance Inspection: Quality conformance inspection shall be in accordance with 4.2 and 4.3 herein and as follows:

4.4.1 Group A Inspection: Group A inspection shall be performed in accordance with 4.1 herein, per MIL-STD-883, Method 5005, and specified in **Table IV** herein.

4.4.2 Group B Inspection: When purchased, a full Group B is performed on an inspection lot. As a minimum, Subgroup B2 (Resistance to Solvents / Mark Permanency) and Subgroup B3 (Solderability) are performed prior to the first shipment from any inspection lot and Attributes provided when a Full Space Data Pack is ordered. Subgroup B5 (Operating Life) is performed on each wafer lot. This subgroup may or may not be from devices built in the same package style as the current inspection lot. Attributes and variables data for this subgroup will be provided upon request at no charge.

4.4.2.1 Group B, Subgroup **2c** = 10%

Group B, Subgroup **3** = 10%

Group B, Subgroup **4** = 5%

Group B, Subgroup **5** = *5%
(*per wafer or inspection lot
whichever is the larger quantity)

Group B, Subgroup **6** = 15%

4.4.2.2 All footnotes pertaining to Table IIa in MIL-STD-883, Method 5005 apply. The quantity (accept number) of all other subgroups are per MIL-STD-883, Method 5005, Table IIa.

4.4.3 Group D Inspection: When purchased, a full Group D is performed on an inspection lot. As a minimum, periodic full Group D sampling is performed on each package family for each

assembly location every 26 weeks. A generic Group D Summary is provided when a full Space Data Pack is ordered.

4.4.3.1 Group D, Subgroups 3, 4 and 5 = 15% each (Sample Size Series).

4.4.3.2 All footnotes pertaining to Table IV in MIL-STD-883, Method 5005 apply. The quantity (accept number) or sample number and accept number of all other subgroups are per MIL-STD-883, Method 5005, Table IV.

4.5 Deliverable Data: Deliverable data that will ship with devices when a Space Data Pack is ordered:

4.5.1 Lot Serial Number Sheets identifying all devices accepted through final inspection by serial number.

4.5.2 100% attributes (completed lot specific traveler; includes Group A Summary)

4.5.3 Burn-In Variables Data and Deltas (if applicable)

4.5.4 Group B2, B3, and B5 Attributes (Variables data, if performed on lot shipping)

4.5.5 Generic Group D data (4.4.3 herein)

4.5.6 SEM photographs (3.13 herein)

4.5.7 Wafer Lot Acceptance Report (3.13 herein)

4.5.8 X-Ray Negatives and Radiographic Report

4.5.9 A copy of outside test laboratory radiation report if ordered

4.5.10 Certificate of Conformance certifying that the devices meet all the requirements of this specification and have successfully completed the mandatory tests and inspections herein.

Note: Items 4.5.1 and 4.5.10 will be delivered as a minimum, with each shipment. This is noted on the Purchase Order Review Form as “No Charge Data”.

5.0 Packaging Requirements: Packaging shall be in accordance with Appendix A of MIL-PRF-38535. All devices shall be packaged in conductive material or packaged in anti-static material with an external conductive field shielding barrier.

DEVICE OPTIONS 1, 2
(H) TO5 / 8 LEADS CASE OUTLINE

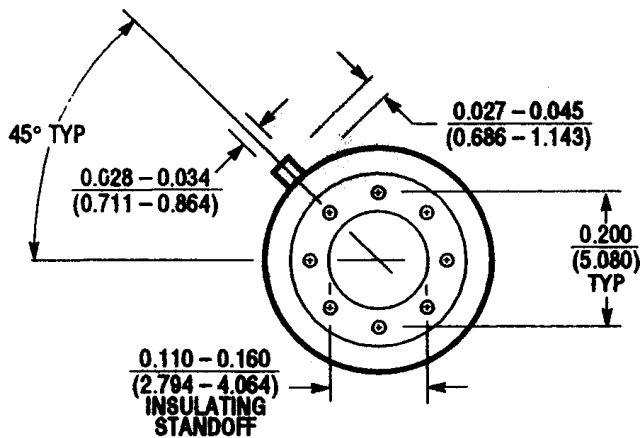
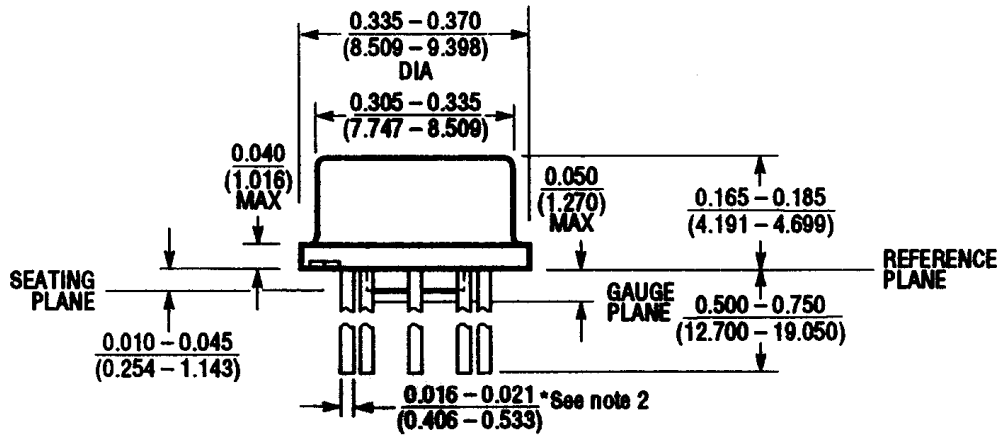

NOTE: 1. LEAD DIAMETER IS UNCONTROLLED BETWEEN THE REFERENCE PLANE AND SEATING PLANE.

2. FOR SOLDER DIP LEAD FINISH, LEAD DIAMETER IS $\frac{0.016 - 0.024}{(0.406 - 0.610)}$

$\theta_{ja} = +150^{\circ}\text{C/W}$

$\theta_{jc} = +40^{\circ}\text{C/W}$

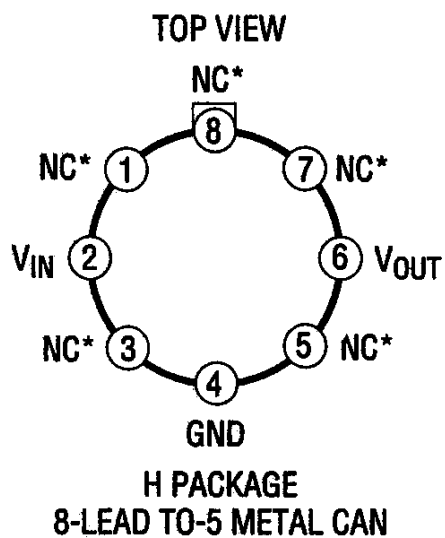
FIGURE 1**DEVICE OPTIONS 1 AND 2**
TERMINAL CONNECTIONS

* Connected internally. Do not connect external circuitry to these pins.

FIGURE 2**DEVICE OPTIONS 1 AND 2
TOTAL DOSE BIAS CIRCUIT**

TABLE I: ELECTRICAL CHARACTERISTICS (PRE-IRRADIATION) NOTE 9

| SYMBOL | PARAMETER | CONDITIONS | NOTES | $T_A = 25^\circ\text{C}$ | | | $-55^\circ\text{C} \leq T_A \leq 125^\circ\text{C}$ | | | SUB-GROUP | UNITS |
|---|--|---|--|--------------------------|------|-----|---|-----|-----|-----------|---------------------|
| | | | | MIN | TYP | MAX | MIN | TYP | MAX | | |
| V_{OUT} | Output Voltage | | 1 | 6.95 | 7.05 | | | | 1 | | V |
| TCV_{OUT} | Output Voltage Temperature Coefficient | RH1021BM-7 | 2 | | | | | 5 | | 2,3 | ppm/°C |
| | | RH1021DM-7 | 2 | | | | | 20 | | 2,3 | ppm/°C |
| $\frac{\Delta V_{OUT}}{\Delta V_{IN}}$ | Line Regulation | $8.5\text{V} \leq V_{IN} \leq 12\text{V}$ | 3 | | 4 | | | 8 | | 2,3 | ppm/V |
| | | $12\text{V} \leq V_{IN} \leq 40\text{V}$ | 3 | | 2 | | | 4 | | 2,3 | ppm/V |
| $\frac{\Delta V_{OUT}}{\Delta I_{OUT}}$ | Load Regulation (Sourcing Current) | $0 \leq I_{OUT} \leq 10\text{mA}$ | 3 | | 25 | | | 40 | | 2,3 | ppm/mA |
| | | Load Regulation (Shunt Mode) | $1.2\text{mA} \leq I_{OUT} \leq 10\text{mA}$ | 3,4 | | 100 | | | 150 | | 2,3 |
| I_S | Supply Current (Series Mode) | | | | 1.2 | | | 1.5 | | 2,3 | mA |
| I_{MIN} | Minimum Current (Shunt Mode) | V_{IN} Is Open | | | 1.0 | | | 0.3 | 1.2 | 2,3 | mA |
| | Output Voltage Noise | $0.1\text{Hz} \leq f \leq 10\text{Hz}$ | 5 | | 4 | | | | | | μV_{P-P} |
| | | $10\text{Hz} \leq f \leq 1\text{kHz}$ | 5 | | 4 | | | | | | μV_{RMS} |
| | Long-Term Stability of V_{OUT} | $\Delta T = 1000$ Hrs Noncumulative | 6 | | 7 | | | | | | ppm |
| | Temperature Hysteresis of V_{OUT} | $\Delta T = \pm 25^\circ\text{C}$ | | | 3 | | | | | | ppm |

SEE TABLE 1 NOTES ON THE FOLLOWING PAGE

TABLE II: ELECTRICAL CHARACTERISTICS (POST-IRRADIATION) NOTE 7

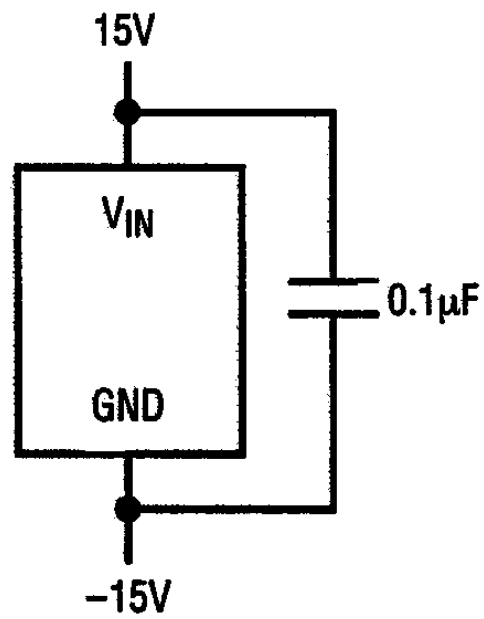
| SYMBOL | PARAMETER | CONDITIONS | NOTES | 10Krad(Si) | | 20Krad(Si) | | 50Krad(Si) | | 100Krad(Si) | | 200Krad(Si) | | UNITS |
|---|--|------------------------------|-------|------------|--------------------------------|------------|-------|------------|-------|-------------|-------|-------------|------|--------|
| | | | | MIN | MAX | MIN | MAX | MIN | MAX | MIN | MAX | MIN | MAX | |
| V_{OUT} | Output Voltage | | 1 | 6.948 | 7.052 | 6.945 | 7.055 | 6.942 | 7.058 | 6.937 | 7.063 | 6.93 | 7.07 | V |
| TCV_{OUT} | Output Voltage Temperature Coefficient | RH1021BM-7 | 2 | | 5 | | 6 | | 8 | | 10 | | 12 | ppm/°C |
| | | RH1021DM-7 | 2 | | 20 | | 21 | | 23 | | 25 | | 28 | |
| $\frac{\Delta V_{OUT}}{\Delta V_{IN}}$ | Line Regulation | $8.5V \leq V_{IN} \leq 12V$ | 3 | | 4 | | 4 | | 4.5 | | 5 | | 6 | ppm/V |
| | | $12V \leq V_{IN} \leq 40V$ | 3 | | 2 | | 2 | | 2 | | 2 | | 3 | |
| $\frac{\Delta V_{OUT}}{\Delta I_{OUT}}$ | Load Regulation (Sourcing Current) | $0 \leq I_{OUT} \leq 10mA$ | 3,8 | | 25 | | 25 | | 25 | | 25 | | 25 | ppm/mA |
| | | Load Regulation (Shunt Mode) | | | 1.2mA $\leq I_{OUT} \leq 10mA$ | 3,4 | | 100 | | 100 | | 100 | | |
| I_{MIN} | Minimum Current (Shunt Mode) | V_{IN} Is Open | | | 1.0 | | 1.0 | | 1.0 | | 1.0 | | 1.0 | mA |
| I_S | Supply Current (Series Mode) | | | | 1.2 | | 1.2 | | 1.2 | | 1.2 | | 1.2 | mA |

Note 1: Output voltage is measured immediately after turn-on. Changes due to chip warm-up are typically less than 0.005%.

Note 2: Temperature coefficient is measured by dividing the change in output voltage over the temperature range by the change in temperature. Separate tests are done for hot and cold; T_{MIN} to 25°C and 25°C to T_{MAX} . Incremental slope is also measured at 25°C.

Note 3: Line and load regulation are measured on a pulse basis. Output changes due to die temperature change must be taken into account separately. Package thermal resistance is 150°C/W for the TO-5 (H) package.

Note 4: Shunt mode regulation is measured with the input open. With the input connected, shunt mode current can be reduced to 0mA. Load regulation will remain the same.

Note 5: RMS noise is measured with a 2-pole highpass filter at 10Hz and a 2-pole lowpass filter at 1kHz. The resulting output is full wave rectified and then integrated for a fixed period, making the final reading an average as opposed to RMS. Correction factors are used to convert from average to RMS and to correct for the nonideal bandpass of the filters. Peak-to-peak noise is measured with a single highpass filter at 0.1Hz and a 2-pole lowpass filter at 10Hz. The unit is enclosed in a still-air environment to eliminate thermocouple effects on the leads. Test time is 10 seconds.

Note 6: Consult factory for units with long term stability data.

Note 7: $V_{IN} = 12V$, $I_{OUT} = 0$, $T_A = 25^\circ C$, unless otherwise noted.

Note 8: $I_{OUT(MAX)}$ (Sourcing) is 5mA for exposures greater than 100Krad (Si).

Note 9: $V_{IN} = 12V$, $I_{OUT} = 0$, unless otherwise noted.

TABLE III: POST BURN-IN ENDPOINTS AND DELTA LIMIT REQUIREMENTS $T_A = 25^\circ\text{C}$

| PARAMETER | ENDPOINT LIMIT | | DELTA | | UNITS |
|-----------|----------------|------|--------|-------|-------|
| | MIN | MAX | MIN | MAX | |
| V_{out} | 6.95 | 7.05 | -0.003 | 0.003 | V |

TABLE IV: ELECTRICAL TEST REQUIREMENTS

| MIL-STD-883 TEST REQUIREMENTS | SUBGROUP |
|--|-------------|
| FINAL ELECTRICAL TEST REQUIREMENTS (METHOD 5004) | 1*, 2, 3, 4 |
| GROUP A TEST REQUIREMENTS (METHOD 5005) | 1, 2, 3, 4 |
| GROUP B AND D FOR CLASS S ENDPOINT ELECTRICAL PARAMETERS (METHOD 5005) GROUP C AND D FOR CLASS B END POINT ELECTRICAL PARAMETERS (METHOD 5005) | 1, 2, 3 |

*PDA APPLIES TO SUBGROUP 1.

PDA TEST NOTE: The PDA is specified as 5% based on failures from Group A, Subgroup 1, tests after cooldown as the final electrical test in accordance with method 5004 of MIL-STD-883. The verified failures of Group A, Subgroup 1 and delta rejects after burn-in divided by the total number of devices submitted for burn-in in that lot shall be used to determine the percent for the lot.