

REVISION RECORD

REV	DESCRIPTION	DATE
0	INITIAL RELEASE	06/01/06
A	<ul style="list-style-type: none"> PAGE 3, PARAGRAPH 3.7.1 CHANGED VERBIAGE PAGE 4, PARAGRAPH 5.8 CHANGED ALLOY 42 TO KOVAR REQUIRED ON TO5 PACKAGE. 	05/06/08
B	<ul style="list-style-type: none"> PAGE 11, ADDED NOTES 2 AND SPECIAL NOTE ON WAFER TESTING AND PERFORMANCE. PAGE 13, CHANGED RH CANNED SAMPLE TABLE III FOR QUALIFYING DICE SALES ADDED TEMPERATURE CYCLE, CONSTANT ACCELERATION & REMOVED PIND TEST. REMOVED THE (H) FORM THE PART NUMBER. 	04/06/09
C	Page 2, amended section 3.3 <u>Special Handling of Dice</u> to more accurately describe our current procedures and requirements.	03/30/12
D	Page 11, amended Table 1 Dice Electrical Characteristic – Element Evaluation to match the new revision of the dice data sheet. Dice data sheet is now broken down into 2 separate electrical test limits: $T_A = 25^{\circ}\text{C}$, $V_S = 5\text{V}$, $V_{CM} = 0.1\text{V}$, $V_{OUT} = 1.4\text{V}$ AND $T_A = 25^{\circ}\text{C}$, $V_S = \pm 15\text{V}$.	10/03/12
E	Page 13, Changed RH Canned Sample Table for Qualifying Dice Sales: Subgroup 6 Sample Size Series changed from 45 (3) to 65 (3). First note had the Sample Size Series from “15%” to “10%”.	07/02/13
F	Page 11, amended Table 1 Dice Electrical Characteristics, parameter I_S , Supply current from $2.3\ \mu\text{A}$ to $75\ \mu\text{A}$ and Minimum Supply Voltage from 350 V to 2.3 V. Deleted $350\ \mu\text{A}$.	06/24/14
G	Updated Die Sales table on pg 13.	03/26/15
H	TO REMOVE SOURCE AND CHANGE LINEAR TO ANALOG	04/22/21

CAUTION: ELECTROSTATIC DISCHARGE SENSITIVE PART

REVISION	PAGE NO.	1	2	3	4	5	6	7	8	9	10	11	12	13			
INDEX	REVISION	G	G	G	G	G	G	G	G	G	G	G	G	G			
REVISION	PAGE NO.																
INDEX	REVISION																
										ANALOG DEVICES INC.							
		ORIG								TITLE: MICROCIRCUIT, RH1078M MICROPOWER, DUAL, SINGLE SUPPLY PRECISION OP AMP							
		DSGN															
		ENGR															
		MFG															
		CM															
		QA															
		PROG								SIZE	CAGE CODE	DRAWING NUMBER		REV			
		FUNCT									64155	05-08-5209		H			
APPLICATION		SIGNOFFS		DATE		CONTRACT:											

FOR OFFICIAL USE ONLY

1.0 SCOPE:

- 1.1 This specification defines the performance and test requirements for a microcircuit processed to a space level manufacturing flow.

2.0 APPLICABLE DOCUMENTS:

- 2.1 Government Specifications and Standards: the following documents listed in the Department of Defense Index of Specifications and Standards, of the issue in effect on the date of solicitation, form a part of this specification to the extent specified herein.

SPECIFICATIONS:

MIL-PRF-38535 Integrated Circuits (Microcircuits) Manufacturing, General Specification for

MIL-STD-883 Test Method and Procedures for Microcircuits

MIL-STD-1835 Microcircuits Case Outlines

- 2.2 Order of Precedence: In the event of a conflict between the documents referenced herein and the contents of this specification, the order of precedence shall be this specification, MIL-PRF-38535 and other referenced specifications.

3.0 REQUIREMENTS:

- 3.1 General Description: This specification details the requirements for the RH1078M, MICROPOWER, DUAL, SINGLE SUPPLY PRECISION OP AMP DICE and Element Evaluation Test Samples, processed to space level manufacturing flow as specified herein.

- 3.2 Part Number: **RH1078M, Dice**

- 3.3 Special Handling of Dice: Rad Hard dice require special handling as compared to standard IC dice. Rad Hard dice are susceptible to surface damage due to the absence of silicon nitride passivation that is present on most standard dice. Silicon nitride protects the dice surface from scratches by its hard and dense properties. The passivation on **Analog Devices** Rad Hard dice is silicon dioxide which is much "softer" than silicon nitride. During the visual and preparation for shipment, ESD safe Tweezers are used and only the edge of the die are touched.

LTC recommends that dice handling be performed with extreme care so as to protect the die surface from scratches. If the need arises to move the die in or out of the chip shipment tray (waffle pack), use an ESD-Safe-Plastic-tipped Bent Metal Vacuum Probe, preferably .020" OD x .010" ID (for use with tiny parts). The wand should be compatible with continuous air vacuums. The tip material should be static dissipative Delrin (or equivalent) plastic.

During die attach, care must be exercised to ensure no tweezers, or other equipment, touch the top of the dice.

- 3.4 The Absolute Maximum Ratings:

Supply Voltage	±22V
Differential Input Voltage	±30V
Input Voltage	Equal to Positive Supply Voltage0.5V Below Negative Supply Voltage
Output Short-Circuit Duration	Indefinite
Operating Temperature Range	-55°C to 125°C

Storage Temperature Range -55°C to 150°C
Lead Temperature (Soldering, 10 sec.) 300°C

- 3.5 Design, Construction, and Physical Dimensions: Detail design, construction, physical dimensions, and electrical requirements shall be specified herein.
- 3.6 Outline Dimensions and Pad Functions: Dice outline dimensions, pad functions, and locations shall be specified in **Figure 1**.
- 3.7 Radiation Hardness Assurance (RHA):
- 3.7.1 The manufacturer shall perform a lot sample test as an internal process monitor for total dose radiation tolerance. The sample test is performed with MIL-STD-883 TM1019 Condition A as a guideline.
- 3.7.2 For guaranteed radiation performance to MIL-STD-883, Method 1019, total dose irradiation, the manufacturer will provide certified RAD testing and report through an independent test laboratory when required as a customer purchase order line item.
- 3.7.3 Total dose bias circuit is specified in **Figure 2**.
- 3.8 Wafer (or Dice) Probe: Dice shall be 100% probed at $T_a = +25^\circ\text{C}$ to the limits shown in **Table I** herein. All reject dice shall be removed from the lot. This testing is normally performed prior to dicing the wafer into chips. Final specifications after assembly are sample tested during the element evaluation.
- 3.9 Wafer Lot Acceptance: Wafer lot acceptance shall be in accordance with MIL-PRF-38535, Appendix A, except for the following: Top side glassivation thickness shall be a **minimum of 4KÅ**.
- 3.10 Wafer Lot Acceptance Report: SEM is performed per MIL-STD-883, Method 2018. Copies of SEM photographs shall be supplied with the Wafer Lot Acceptance Report as part of a Space Data Pack when specified as a customer purchase order line item.
- 3.11 Traceability: Wafer Diffusion Lot and Wafer traceability shall be maintained through Quality Conformance Inspection.
- 4.0 **QUALITY CONFORMANCE INSPECTION**: Quality Conformance Inspection shall consist of the tests and inspections specified herein.
- 5.0 **SAMPLE ELEMENT EVALUATION**: A sample from **each wafer supplying dice** shall be assembled and subjected to element evaluation per **Table III** herein.
- 5.1 100 Percent Visual Inspection: All dice supplied to this specification shall be inspected in accordance with MIL-STD-883, Method 2010, Condition A. All reject dice shall be removed from the lot.
- 5.2 Electrical Performance Characteristics for Element Evaluation: The electrical performance characteristics shall be as specified in **Table I** and **Table II** herein.
- 5.3 Sample Testing: Each wafer supplying dice for delivery to this specification shall be subjected to element evaluation sample testing. No dice shall be delivered until all the lot sample testing has been performed and the results found to be acceptable unless the customer supplies a written approval for shipment prior to completion of wafer qualification as specified in this specification.

5.4 Part Marking of Element Evaluation Sample Includes:

5.4.1 LTC Logo

5.4.2 LTC Part Number

5.4.3 Date Code

5.4.4 Serial Number

5.4.5 ESD Identifier per MIL-PRF-38535, Appendix A

5.4.6 Diffusion Lot Number

5.4.7 Wafer Number

5.5 Burn-In Requirement: Burn-In circuit for TO5 package is specified in **Figure 3**.

5.6 Mechanical/Packaging Requirements: Case Outline and Dimensions are in accordance with **Figure 4**.

5.7 Terminal Connections: The terminal connections shall be as specified in **Figure 5**.

5.8 Lead Material and Finish: The lead material and finish shall be Kovar with hot solder dip (Finish letter A) in accordance with MIL-PRF-38535.

6.0 VERIFICATION (QUALITY ASSURANCE PROVISIONS)

6.1 Quality Assurance Provisions: Quality Assurance provisions shall be in accordance with MIL-PRF-38535. **Analog Devices** is a QML certified company and all Rad Hard candidates are assembled on qualified Class S manufacturing lines.

6.2 Sampling and Inspection: Sampling and Inspection shall be in accordance with **Table III** herein.

6.3 Screening: Screening requirements shall be in accordance with **Table III** herein.

6.4 Deliverable Data: Deliverable data that will ship with devices when a Space Data Pack is ordered:

6.4.1 Lot Serial Number Sheets identifying all Canned Sample devices accepted through final inspection by serial number.

6.4.2 100% attributes (completed element evaluation traveler).

6.4.3 Element Evaluation variables data, including Burn-In and Op Life

6.4.4 SEM photographs (3.10 herein)

6.4.5 Wafer Lot Acceptance Report (3.9 herein)

6.4.6 A copy of outside test laboratory radiation report if ordered

6.4.7 Certificate of Conformance certifying that the devices meet all the requirements of this specification and have successfully completed the mandatory tests and inspections herein.

Note: Items 6.4.1 and 6.4.7 will be delivered as a minimum, with each shipment.

7.0 Packaging Requirements: Packaging shall be in accordance with Appendix A of MIL-PRF-38535. All dice shall be packaged in multicavity containers composed of conductive, anti-static, or static dissipative material with an external conductive field shielding barrier.

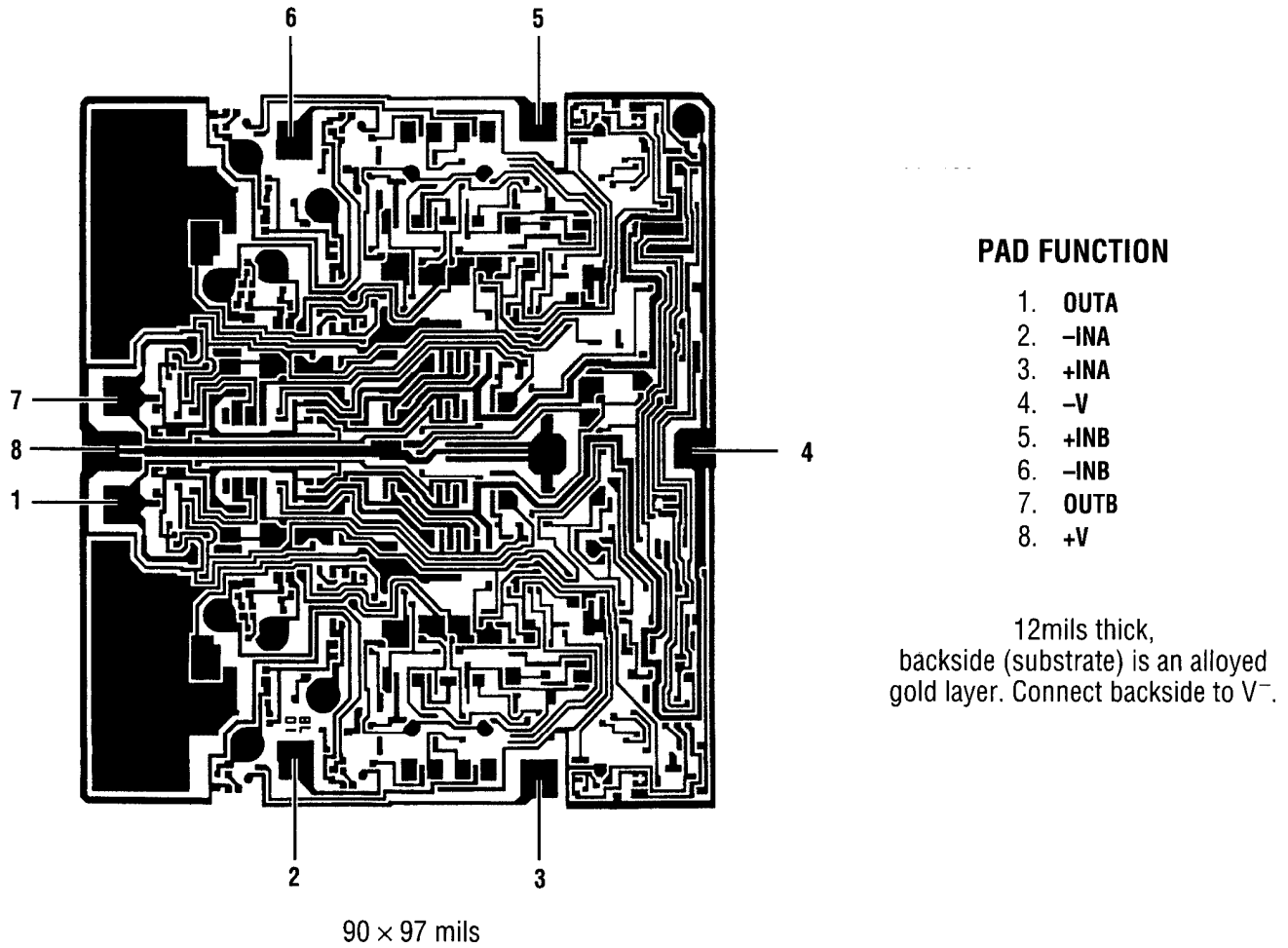
DICE OUTLINE DIMENSIONS AND PAD FUNCTIONS**FIGURE 1**

TOTAL DOSE BIAS CIRCUIT

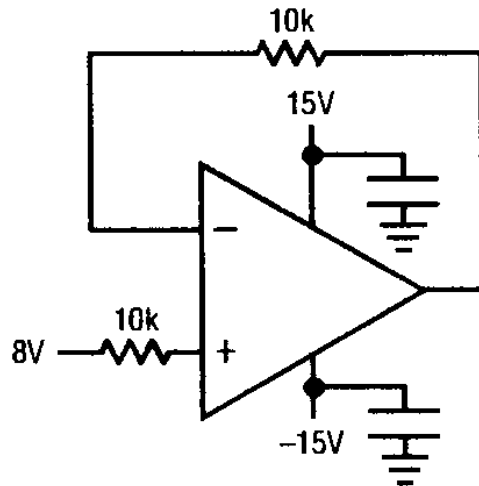
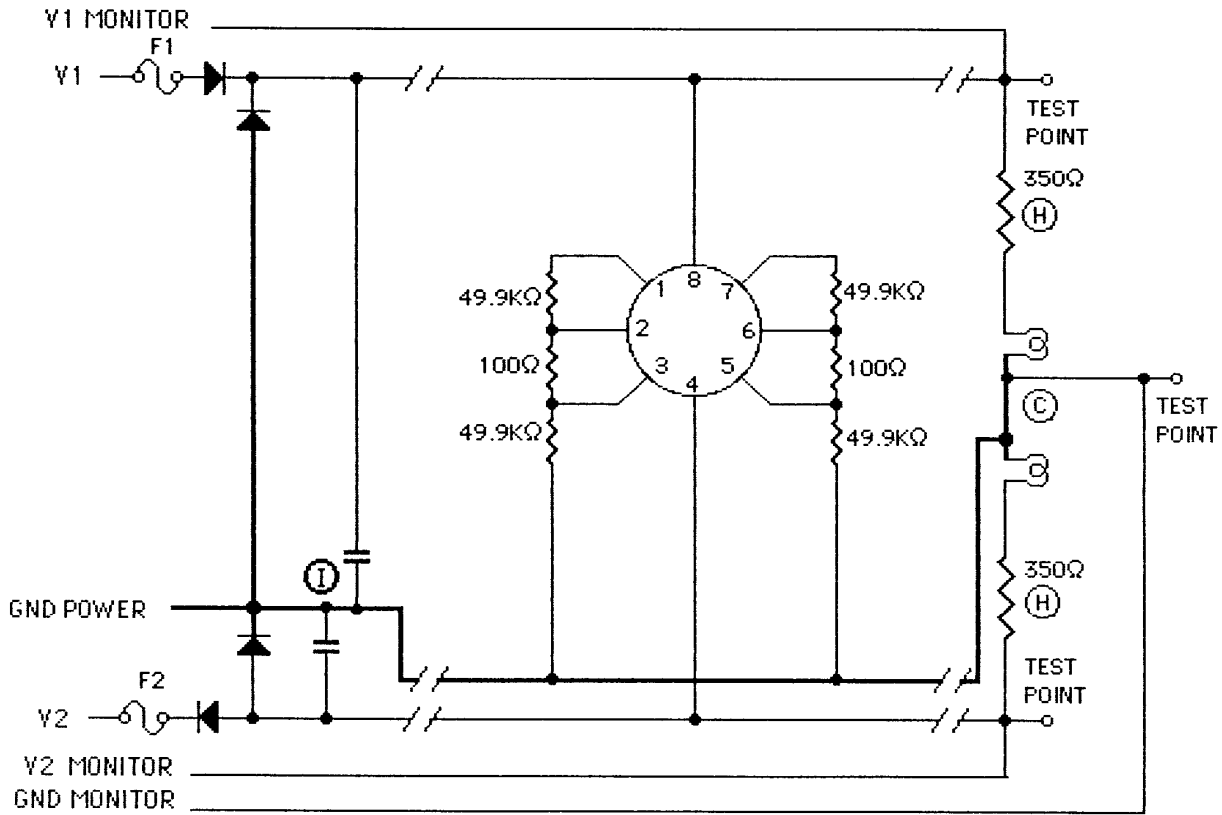

FIGURE 2

BURN-IN CIRCUIT



NOTES:

1. Unless otherwise specified, component tolerances shall be per military specification.
2. $T_j = +134^\circ\text{C}$ maximum.
3. $T_a = +125^\circ\text{C}$.
4. Burn-in Voltages: $V_1 = +20\text{V}$ to $+22\text{V}$
 $V_2 = -20\text{V}$ to -22V

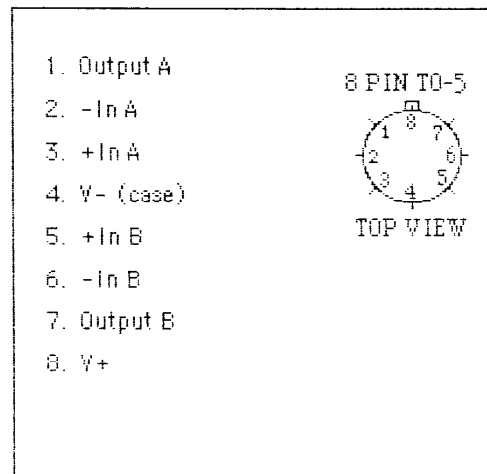

PACKAGE

FIGURE 3

TO5, 8 LEADS, CASE OUTLINE

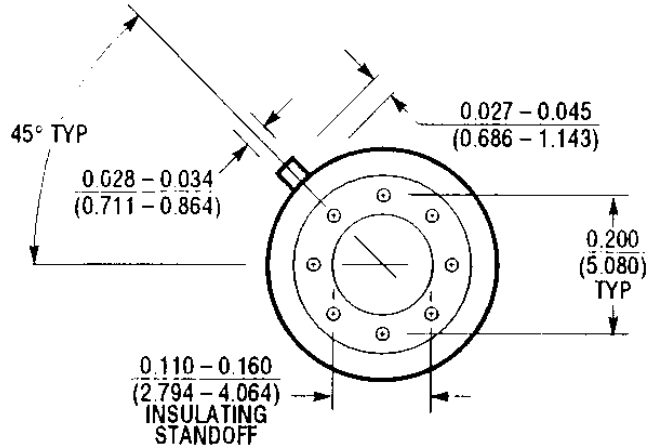
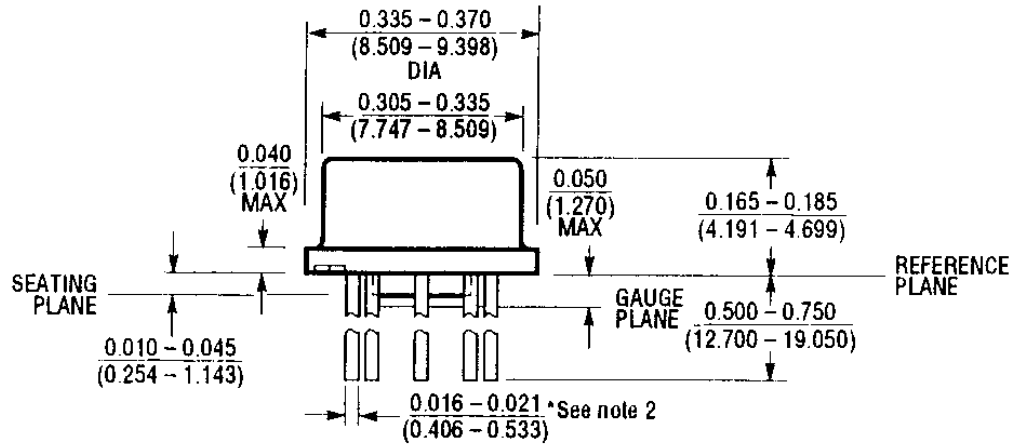

- NOTE: 1. LEAD DIAMETER IS UNCONTROLLED BETWEEN THE REFERENCE PLANE AND SEATING PLANE.
 2. FOR SOLDER DIP LEAD FINISH, LEAD DIAMETER IS $0.016 - 0.024$ (0.406 - 0.610)

$\theta_{ja} = +150^\circ\text{C/W}$
 $\theta_{jc} = +40^\circ\text{C/W}$

FIGURE 4

TERMINAL CONNECTIONS**FIGURE 5**

TABLE I DICE ELECTRICAL CHARACTERISTICS – Element Evaluation (Note 1)**DICE ELECTRICAL TEST LIMITS** $T_A = 25^\circ\text{C}$, $V_S = 5\text{V}$, $V_{CM} = 0.1\text{V}$, $V_{OUT} = 1.4\text{V}$, unless otherwise specified.

SYMBOL	PARAMETER	CONDITIONS	MIN	MAX	UNITS
A_{VOL}	Large-Signal Voltage Gain	$V_O = 0.03\text{V to } 4\text{V}$, No Load	150		V/mV
		$V_O = 0.03\text{V to } 3.5\text{V}$, $R_L = 50\text{k}$	120		V/mV
		$V_O = 0.05\text{V to } 4\text{V}$, No Load			V/mV
		$V_O = 0.05\text{V to } 3.5\text{V}$, $R_L = 50\text{k}$			V/mV
V_{OUT}	Output Voltage Swing	Output Low, No Load		6	mV
		Output Low, 2k to GND		2	mV
		Output Low, $I_{SINK} = 100\mu\text{A}$		130	mV
		Output High, No Load	4.2		V
		Output High, 2k to GND	3.5		V
SR	Slew Rate	$A_V = 1$, $V_S = \pm 2.5\text{V}$	0.04		V/ μs
I_S	Supply Current	Per Amplifier		75	μA
	Minimum Supply Voltage	Note 2		2.3	V

 $T_A = 25^\circ\text{C}$, $V_S = \pm 15\text{V}$, unless otherwise specified.

SYMBOL	PARAMETER	CONDITIONS	MIN	MAX	UNITS
V_{OS}	Input Offset Voltage			350	μV
I_{OS}	Input Offset Current			0.8	nA
I_B	Input Bias Current			15	nA
	Input Voltage Range		13.5 -15.0		V V
CMRR	Common Mode Rejection Ratio	$V_{CM} = 13.5\text{V, } -15\text{V}$	97		dB
		$V_{CM} = 13\text{V, } -14.9\text{V}$			dB
PSRR	Power Supply Rejection Ratio	$V_S = 5\text{V}$, 0V to $\pm 18\text{V}$	100		dB
A_{VOL}	Large-Signal Voltage Gain	$V_O = \pm 10\text{V}$, $R_L = 50\text{k}$	1000		V/mV
		$V_O = \pm 10\text{V}$, $R_L = 2\text{k}$	300		V/mV
		$V_O = \pm 10\text{V}$, $R_L = 5\text{k}$			V/mV
V_{OUT}	Output Voltage Swing	$R_L = 50\text{k}$	± 13		V
		$R_L = 2\text{k}$	± 11		V
		$R_L = 5\text{k}$			V
SR	Slew Rate		0.06		V/ μs
I_S	Supply Current	Per Amplifier		100	μA

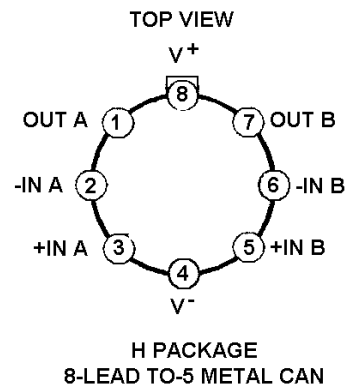
Note 1: Stresses beyond those listed under Absolute Maximum Ratings may cause permanent damage to the device. Exposure to any Absolute Maximum Rating condition for extended periods may affect device reliability and lifetime.

Note 2: Power supply rejection ratio is measured at the minimum supply voltage.

Wafer level testing is performed per the indicated specifications for dice. Considerable differences in performance can often be observed for dice versus packaged units due to the influences of packaging and assembly on certain devices and/or parameters. Please consult factory for more information on dice performance and lot qualifications via lot sampling test procedures.

Dice data sheet subject to change. Please consult factory for current revision in production.

TABLE II ELECTRICAL CHARACTERISTICS – Post-Irradiation **$V_S = 5V$, $0V$, $V_{CM} = 0.1V$, $V_O = 1.4V$, $T_A = 25^\circ C$ unless otherwise noted.**

SYMBOL	PARAMETER	CONDITIONS	10KRAD(Si)		25KRAD(Si)		50KRAD(Si)		75KRAD(Si)		100KRAD(Si)		UNITS
			MIN	MAX	MIN	MAX	MIN	MAX	MIN	MAX	MIN	MAX	
V_{OS}	Input Offset Voltage		120		175		250		500				μV
I_{OS}	Input Offset Current		2		8		13		18				nA
I_B	Input Bias Current		20		40		80		100				nA
	Input Voltage Range		3.5		3.5		3.5		3.5				V
CMRR	Common-Mode Rejection Ratio	$V_{CM} = 0V$ to $3.5V$	91		89		87		85				dB
PSRR	Power Supply Rejection Ratio	$V_S = 2.3V$ to $12V$	100		100		98		88				dB
A_{VOL}	Large-Signal Voltage Gain	$V_O = 0.03V$ to $4V$, No Load $V_O = 0.03V$ to $3.5V$, $R_L = 50k$	150 120		150 50		100 20		50 10				V/mV V/mV
V_{OUT}	Output Voltage Swing	Output Low, No Load Output Low, $2k$ to GND Output Low, $I_{SINK} = 100\mu A$ Output High, No Load Output High, $2k$ to GND	6 2 130		9 2 140		13 2 150		20 2 160				mV mV mV V V
S_R	Slew Rate	$A_V = 1$, $V_S = \pm 2.5V$	0.04		0.03		0.02		0.01				V/ μs
I_S	Supply Current	per Amplifier	75		75		75		75				μA

 $V_S = \pm 15V$ unless otherwise noted.

SYMBOL	PARAMETER	CONDITIONS	10KRAD(Si)		25KRAD(Si)		50KRAD(Si)		75KRAD(Si)		100KRAD(Si)		UNITS
			MIN	MAX	MIN	MAX	MIN	MAX	MIN	MAX	MIN	MAX	
V_{OS}	Input Offset Voltage		350		500		650		800		1000		μV
I_{OS}	Input Offset Current		2		8		13		18		23		nA
I_B	Input Bias Current		20		40		80		100		120		nA
	Input Voltage Range		13.5 -15.0		13.5 -15.0		13.5 -15.0		13.5 -15.0		13.5 -15.0		V V
CMRR	Common-Mode Rejection Ratio	$V_{CM} = 13.5V$, $-15V$	94		92		90		88		86		dB
PSRR	Power Supply Rejection Ratio	$V_S = 5V$, $0V$ to $\pm 18V$	100		100		98		88		78		dB
A_{VOL}	Large-Signal Voltage Gain	$V_O = 10V$, $R_L = 50k$ $V_O = 10V$, $R_L = 2k$	1000 300		700 200		400 120		150 45		50 15		V/mV V/mV
V_{OUT}	Output Voltage Swing	$R_L = 50k$ $R_L = 2k$	± 13 ± 11		± 13 ± 11		± 13 ± 11		± 13 ± 11		± 13 ± 10		V V
SR	Slew Rate		0.05		0.04		0.03		0.02		0.01		V/ μs
I_S	Supply Current	per Amplifier	100		100		100		100		100		μA

TABLE III RH ELEMENT EVALUATION TABLE QUALIFICATION OF DICE SALES**RH CANNED SAMPLE TABLE FOR QUALIFYING DICE SALES**

SUBGROUP	CLASS			OPERATION	MIL-STD-883			QUANTITY (ACCEPT NUMBER) REF. METHOD 2018 FOR S/S
	K/S	V	H/B		METHOD	CONDITION		
1	X	X		SEM	2018	N/A	100%	
2	X	X	X	ELEMENT ELECTRICAL (WAFER SORT @ 25°C)				
3	X	X	X	ELEMENT VISUAL (2nd OP)	2010	A	100%	
4	X	X	X	INTERNAL VISUAL (3rd OP)	2010	A	ASSEMBLED PARTS ONLY	
	X	X		DIE SHEAR MONITOR	2019			
	X	X		BOND PULL MONITOR	2011			
5	X	X		STABILIZATION BAKE	1008	C	ASSEMBLED PARTS ONLY	
	X	X		TEMPERATURE CYCLE	1010	C		
	X	X		CONSTANT ACCELERATION	2001	E		
	X	X		FINE LEAK	1014	A		
	X	X		GROSS LEAK	1014	C		
6	X	X		FIRST ROOM ELECTRICAL - READ & RECORD (REPLACE ANY ASSEMBLY-RELATED REJECTS)			45(0)	
	X	X		PRE BURN-IN ELECT. READ & RECORD @ +125°C or +150°C, -55°C				
	X	X		BURN-IN: +125°C/240 hrs. or +150°C/120 hrs.	1015	+ 125°C MINIMUM 240 HOURS		
	X	X		POST BURN-IN ELECT. READ & RECORD @ 25°C				
	X	X		POST BURN-IN ELECT. READ & RECORD @ +125°C or +150°C, -55°C				
	X	X		TOTAL IRRADIATION DOSE	1019	A		
	X	X		PRE OP-LIFE ELECTRICAL @ 25°C READ & RECORD				
	X	X		OPERATING LIFE: +125°C/1000 hrs. or +150°C/500 hrs	1005	+ 125°C MINIMUM 1000 HOURS		
	X	X		POST OP-LIFE ELECT. (R & R @ 25°C, +125°C DR +150°C, -55°C				
7	X	X	X	WIRE BOND EVALUATION	2011		15(0) OR 25(1) - # of wires	

NOTE:

LTC is not qualified to process to MIL-PRF-38534. This is an LTC imposed element evaluation that follows MIL-STD-883 test methods and conditions. Please note the quantity and accept number from Sample Size Series of 5%, accept on 0, and note that the actual sample and accept number does not begin until Subgroup 6 OP-LIFE.

NOTE:

Tests within Subgroup 5 may be performed in any sequence.

NOTE:

LTC's radiation tolerance (RH) die has a topside glassivation thickness of 4KA minimum.

NOTE:

Sample sizes on the travelers may be larger than that indicated in the above table; however, the larger sample size is to accommodate extra units for replacement devices in the event of equipment or operator error and for assembly related rejects in Subgroup 6, and for Wire Bond Evaluation, Subgroup 7. The larger sample size is at all times kept segregated and, if used for qualification, has all the required processing imposed.