

SSM2005

FEATURES

- Generates True 5-Channel Soundfield
- No Pre-Encoding Required—Only Stereo L and R
- Excellent Surround Image At All Positions
- Superior Sound in Automobiles
- Distinct Left Rear vs. Right Rear, Full Bass Response
- No Delay Required—Natural Ambiance Preserved
- 4 or 5 Speaker Operation
- Full Bandwidth on All Channels
- Optimized for Music Reproduction
- Superior Decoding of Dolby* Surround Material
- Excellent Decoding of "Pre-Encoded" Sources
- Usable in Home Theater and Video Games
- +7 V to +20 V Operation

GENERAL DESCRIPTION

The SSM2005 Circle Surround 5-Channel Soundfield Generator produces a true 5-channel surround soundfield using only standard unencoded left/right stereo sources. Left front, right front, center, and differentiated left and right rear channels are generated providing a realistic ambiance effect with either 4 or 5 speaker configurations. Unlike previous designs, Circle Surround is optimized for music reproduction with full bandwidth on all channels and proper separation of the front channels. The differentiated rear channels provide excellent imaging, especially in automotive applications. Listener position is not critical; well-balanced sound is obtained anywhere within the soundfield.

The Circle Surround process does not require the audio signal to be encoded, as it uses the ambiance and directional information already present in the original media to generate the multidimensional effects. Circle Surround does not add any ar-

CIRCLE SURROUND SYSTEM BLOCK DIAGRAM

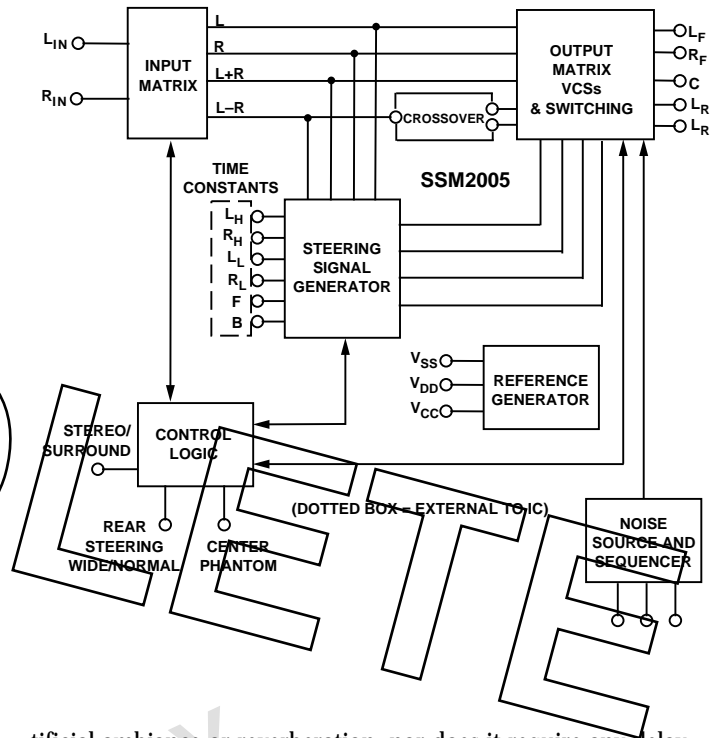

tificial ambiance or reverberation, nor does it require any delay generators. The fully differentiated rear channels provide rear stereo separation for enhanced spatial perception while maintaining full bass response, especially important in automotive applications.

*Dolby is a registered trademark of Dolby Laboratories, Inc.

†Circle Surround is a registered trademark of Rocktron Corporation and is protected by patents granted and applied for.