



Advanced Micro Devices

SiS741CX Chipset for AMD SOCKET-A,
DDR SDRAM Demo Board Schematics
(11/7/2005) Rev : 6



PAGE	Content	PAGE	Content
1	Cover Page	31	Data Acquisition & Jumpers
2	SiS741GX System Block Diagram	32	AC'97 Codec (ALC203/WM9712L)
3	Power Supply Block Diagram	33	Audio INPUT & OUTPUT
4	Revision History	34	ROM
5	Notes	35	RTC (3V)
6	SOCKETA-1	36	VCC1.8V & SB1.8V & SB3V & VDDQ & IVDD & AUX_IVDD
7	SOCKETA-2	37	VCC3_DUAL & VCC5_DUAL & VCC1.8_DUAL
8	SOCKETA-3	38	VCC_M & SB_M & DDR_VTT (DDR SDRAM)
9	SiS 741CX-1 (Host/AGP)	39	VCC_DIMM (DDR SDRAM)
10	SiS 741CX-2 (Memory for SDRAM)	40	FAN5240 NX Processor PWM
11	SiS 741CX-3 (MuTIOL/VGA/Others)	41	NX Processor VID Mux
12	SiS 741CX-4 (Powers)	42	Power Connector
13	SiS 964-1 (PCI/IDE/MuTIOL)	43	LCD interface
14	SiS 964-2 (Misc. Signals)	44	
15	SiS 964-3 (USB/SATA)	45	
16	SiS 964-4 (Powers)	46	
17	HARDWARE TRAP(For 964)	47	
18	Main Clock Generator(For 964)	48	
19	Clock Buffer-1 (for DDR SDRAM)	49	
20	DDR SDRAM	50	
21	DDR SDRAM SSTL-2 Termination Resistors	51	
22	VGA Connector	52	
23	IDE Connector	53	
24	PCI Slot 1	54	
25	USB Connectors	55	
26	LAN PHY (OPTION:RTL8201) AND RJ45	56	
27	Keyboard & Mouse Connectors	57	
28	W83697HF-1 (SUPER I/O OPTION: 2)	58	
29	W83697HF-2 (COM and Print Port)	59	
30	W83697HF-4 (Hardware Monitor)	60	

(c) 2005 Advanced Micro Devices, Inc. All rights reserved.

AMD, the AMD Arrow logo and combinations thereof, and Geode are trademarks of Advanced Micro Devices, Inc. Other product names used in this publication are for identification purposes only and may be trademarks of their respective companies.

The contents of this document are provided in connection with Advanced Micro Devices, Inc. ("AMD") products. AMD makes no representations or warranties with respect to the accuracy or completeness of the contents of this publication and reserves the right to make changes to specifications and product descriptions at any time without notice. No license, whether express, implied, arising by estoppel or otherwise, to any intellectual property rights is granted by this publication. Except as set forth in AMD's Standard Terms and Conditions of Sale, AMD assumes no liability whatsoever, and disclaims any express or implied warranty, relating to its products including, but not limited to, the implied warranty of merchantability, fitness for a particular purpose, or infringement of any intellectual property right. AMD's products are not designed, intended, authorized or warranted for use as components in systems intended for surgical implant into the body, or in other applications intended to support or sustain life, or in any other application in which the failure of AMD's product could create a situation where personal injury, death, or severe property or environmental damage may occur. AMD reserves the right to discontinue or make changes to its products at any time without notice.

AMD/LOGIC CONFIDENTIAL

Design Create Date = Monday, December 22, 2003

		LOGIC PRODUCT DEVELOPMENT	411 WASHINGTON AVE. N MINNEAPOLIS, MN 55401 PHONE: (612) 672-9495 FAX: (612) 672-9489
--	--	--	--

Title Cover Page			
Size B	Number 1002124	Rev 6	
Date Thursday, March 23, 2006	Project AMD Geode NX	Sheet 1 Of 43	

Note:
Do not include the schematic
when create netlist.

System Block Diagram

SIS741GX for AMD SOCKET-A, DEMO BOARD FULL FUNCTION BLOCK

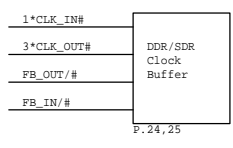
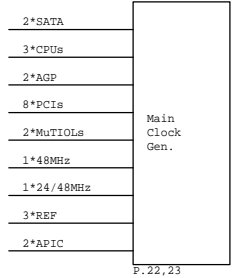
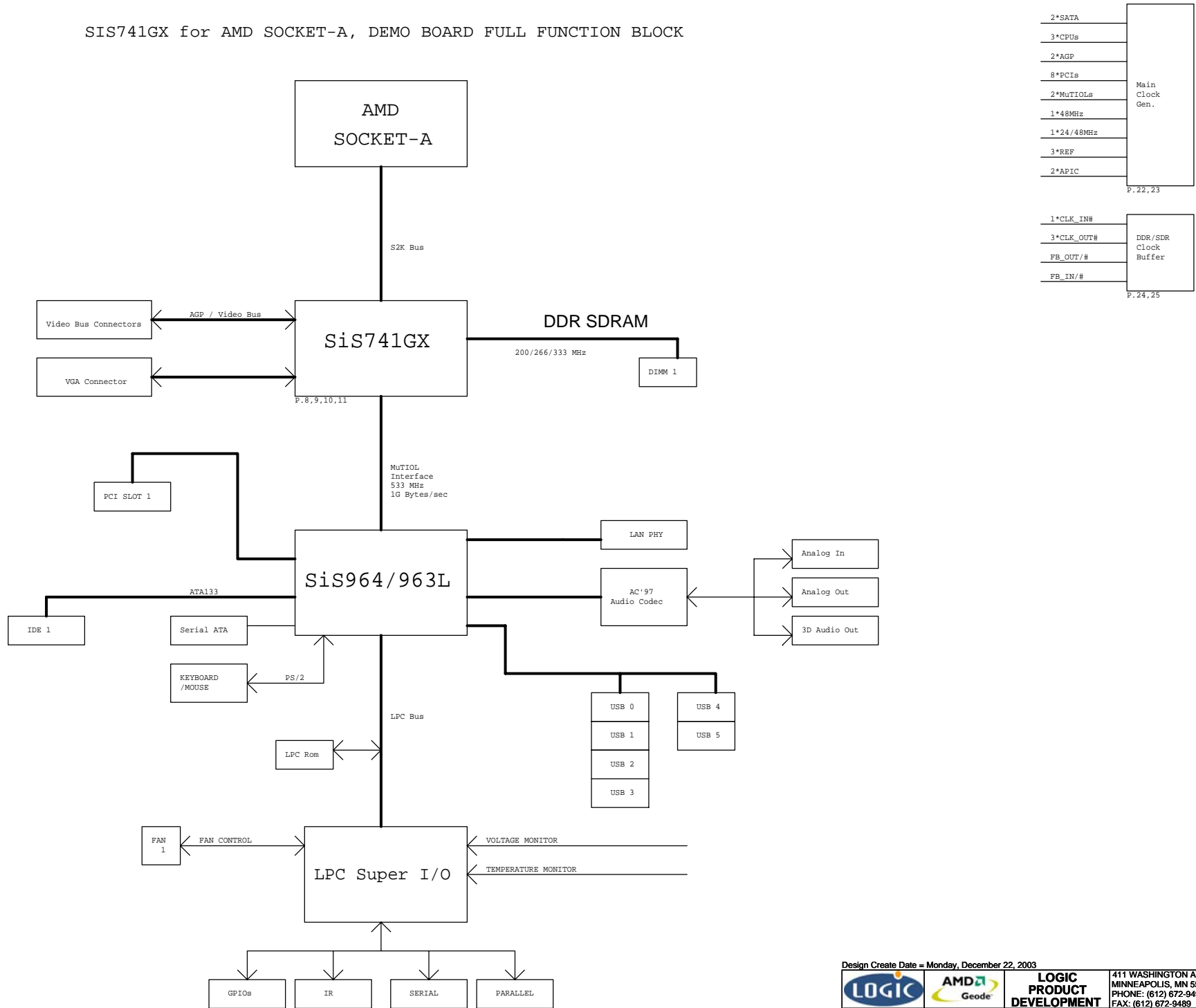

Design Create Date = Monday, December 22, 2003

		LOGIC PRODUCT DEVELOPMENT	411 WASHINGTON AVE. N MINNEAPOLIS, MN 55401 PHONE: (612) 672-9495 FAX: (612) 672-9489
Title Eagle System Block diagram			
Size B	Number 1002124	Project AMD Geode NX	Rev 6
Date Friday, January 13, 2006	Sheet 2	Of 43	1

Power Supplies

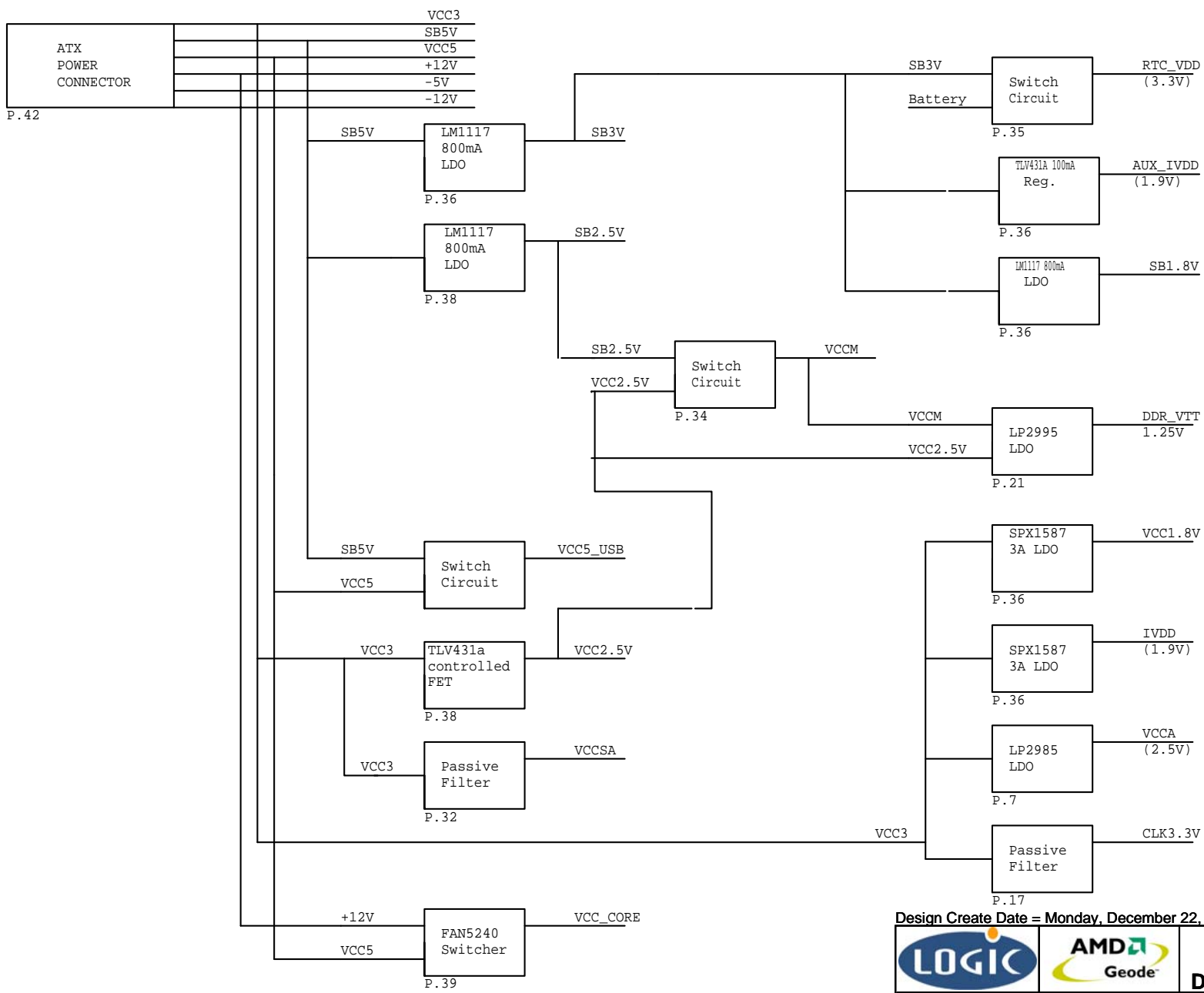

Design Create Date = Monday, December 22, 2003

 	LOGIC PRODUCT DEVELOPMENT	411 WASHINGTON AVE. N MINNEAPOLIS, MN 55401 PHONE: (612) 672-9495 FAX: (612) 672-9489
		Title Power block diagram

Size A	Number 1002124	Rev 6
Date Friday, January 13, 2006	Project AMD Geode NX	Sheet 3 Of 43

DATE	Rev	Description
1/30/2005	1.0	The initial version for proto build 1 (30 boards).
3/1/2005	2.0	<p>Proto build 2 (30 boards).</p> <p>1) Page 6 Added NX1500 Processor part number to schematic. 2) Page 7 Changed R54 (0 Ohm) from 0805 to 0603 3) Page 7 R46,R51 changed from 0603 to 0402. 4) Page 7 Changed HDT header to "do not populate". 5) Page 9 Changed R62 from 60 to 60.4 Ohms, changed Q49 6) Page 18 Changed R197 from 0 Ohms to 10 Ohms 7) Page 18 C141, C142, C144 (10pF) Changed from "do not populate" to installed. 8) Page 22 UDI-UD7 PCB footprint corrected. 9) Page 25, 26 Changed Ethernet/USB connector to no-cap, symmetrical. 10) Page 26 Connect pins 11,17 of U8 to ground. 11) Page 26,29,42 Changed manufacturer of Ferrite L35-L37, FB14 to Steward. 12) Page 29 CN1-CN4, C231 changed from 180pF to 220pF. 13) Page 32 R370 Changed from installed to "do not populate". 14) Page 34 Added EEPROM info to EEPROM socket. 15) Page 35 Added battery (CR2032) to schematic. 16) Page 35 Added jumper JP39 to 3 pin header. 17) Page 36 R398 Changed from 5% to 1%. 18) Page 40 Isolated FAN5420 grounds from DIG GND 19) Page 42 R42 Changed from 10k to 75k. 20) Page 43 Changed LCD voltage selector header to 3 pin to avoid power supply shorting. 21) Page 48 Q49 from IRFWS10A to IRFWS20A 22) Page 37 Changed 2 USB power supply caps from 2 ELE to 1 TAN and 1 ELE. 23) Page 41 Added buffers to reset circuit, so NB,SB,CPU,VID_MUX have individual resets.</p>
5/9/2005	3.0	<p>Rev 3 PC board.</p> <p>1) Page 7 Changed HDT pullup resistors, R31-R35, to 270 Ohms. 2) Page 7 Changed comparator to dual comparator for cost reduction. Added R483 as a pullup for the output. 3) Page 7 Changed C10 to 22uF 10V SMT TAN. 4) Page 7 Changed R19,R26,R27,R37-40,R42-44 from 680 1% to 680 5%. 5) Page 7 Changed R17,R18 from 470 1% to 470 5%. 6) Page 7 Changed R45 from 270 1% to 270 5%. 7) Page 9 For AGP voltage change, R29 moved from VCC_CORE to 3.3V. 8) Page 9 For AGP voltage change, R58, R63 moved from 1.8V to 3.3V. 9) Page 9 Moved LCD_LCD_EN- and BKLTEN from 964 (page 14) to 741. 10) Page 9 Changed R70 from 10 1% to 10 5%. 11) Page 10 Changed R98-99,R105-108,R474-475 from 10 1% to 10 5%. 12) Page 12 For AGP voltage change, C57,C65,CC92,C94,C97 moved from 1.8V to 3.3V. 13) Page 12 For AGP voltage change, 741 VDDQ power pins (9) moved from 1.8V to 3.3V. 14) Page 12 Changed C55, C56, C57, C62 to larger 1206 footprint. 15) Page 16 Changed C133, C134, C135 to larger 1206 footprint. 16) Page 18 Added 10K resistor R30 to pull up gate of Q5. 18) Page 18 Changed C145, C147 to larger 1206 footprint. 19) Page 18 Changed R190,R192,R197,R199,R200 from 10 Ohm 1% to 10 Ohm 5%. 20) Page 15 Changed CB37, CB40, CB41, CB45 to 22uF 10V SMT TAN. 21) Page 19 Changed C168, C171 to 22uF 10V SMT TAN. 22) Page 19 Changed C162 to larger 1206 footprint. 23) Page 21 Changed C176 to larger 1206 footprint. 24) Page 23 Changed R269 from 470 1% to 470 5%. 25) Page 24 Added 1uF 16V CER (C257) to 12V at PCI conn. Added 22uF 6.3V CER (C251,C252) to 5V and 3.3Vat PCI conn. 26) Page 25 Change C199 from SMT Tantalum to ELE. 27) Page 25 Changed R275,R277,R279 from 560K 1% to 560K 5%. 28) Page 26 Changed routing to RN43 and RN44 to minimize solder shorts. 29) Page 28 Added C358 to battery monitor input. 30) Page 28 Remove SIO OVT# pin from THERM- net. 31) Page 29 Changed serial port wake-up circuit. 32) Page 30 Add circuit to latch output of thermal monitor chip. Added U22 and C41. Removed Q48 and R322. 33) Page 30 Changed C232 to 22uF 16V SMT ELE. 34) Page 32 Changed C279 to larger 1206 footprint. 35) Page 33 Change C286, C287 from SMT Tantalum to SMT ELE. 36) Page 35 Changed C293, C294, C297 to larger 1206 footprint. 37) Page 36 Changed C298 to 22uF 10V SMT TAN. 38) Page 36 Changed C304 to larger 1206 footprint. 39) Page 36 Changed R395 to 47 Ohms to change IVDD from 1.9V to 1.7V. 40) Page 38 Changed C317 to 22uF 10V SMT TAN. 41) Page 38 Change R408 to 130 Ohms to change 2.5V supply from 2.48V to 2.55V. 42) Page 40 Changed FAN5420 softstart cap C326 from .1uF to .22uF. 43) Page 40 Re-loaded R417,R418, R423,R426 to correct incorrect footprint. 44) Page 42 Changed C337 to 22uF 10V SMT TAN. 45) Page 42 Changed R329 from 10 Ohm 1% to 10 Ohm 5%. 46) Page 43 Inverted LCD power enable by adding Q11 and R416. 47) Page 43 Change LCD Data Enable resistor, R461, to installed.</p>
7/10/2005	4.0	<p>Rev 4 PC board.</p> <p>1) Page 7 Added pull-up 680 ohm (R66) to PLL_TEST#. 2) Page 9 For AGP voltage change, R58, R63 moved from 3.3V to 1.8V. 3) Page 12 For AGP voltage change, C57,C65,CC92,C94,C97 moved from 3.3V to 1.8V. 4) Page 12 For AGP voltage change, 741 VDDQ power pins (9) moved from 3.3V to 1.8V. 5) Page 33 Re-loaded J7 to correct incorrect footprint.</p>
11/7/2005	5.0	<p>Rev 5 PC board.</p> <p>1) Page 34 Changed U14 supply voltage from 5V to 3.3V. 2) Page 36 Changed R395 from 47 Ohms to 49.9 Ohms to increase the 1.7V supply by 28 mV. 3) Page 43 Added I2C bus to TFT connectors through 00hm resistors. 4) Page 9 Added a testpoint to U4.D7, SBA0</p>
01/13/2006	6.0	<p>Rev 6 PC board.</p>

Design Create Date = Monday, December 22, 2003



**LOGIC
PRODUCT
DEVELOPMENT**

411 WASHINGTON AVE. N
MINNEAPOLIS, MN 55401
PHONE: (612) 672-9495
FAX: (612) 672-9489

Title Revision History			
Size	B	Number	1002124
Rev	6		
Date	Friday, January 13, 2006	Project	AMD Geode NX
Sheet	4	Of	43

8

Rev

Description

Page

2/01/05

7

6

5

4

3

2

1

D

C

B

A

Design Create Date = Monday, December 22, 2003



**LOGIC
PRODUCT
DEVELOPMENT**

411 WASHINGTON AVE. N
MINNEAPOLIS, MN 55401
PHONE: (612) 672-9495
FAX: (612) 672-9489

Title Notes

Size B Number 1002124 Rev 6

Date Friday, January 13, 2006 Project AMD Geode NX Sheet 5 Of 43

8

7

6

5

4

3

2

1

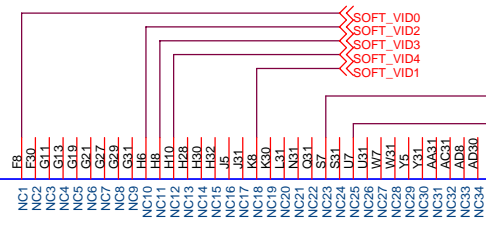
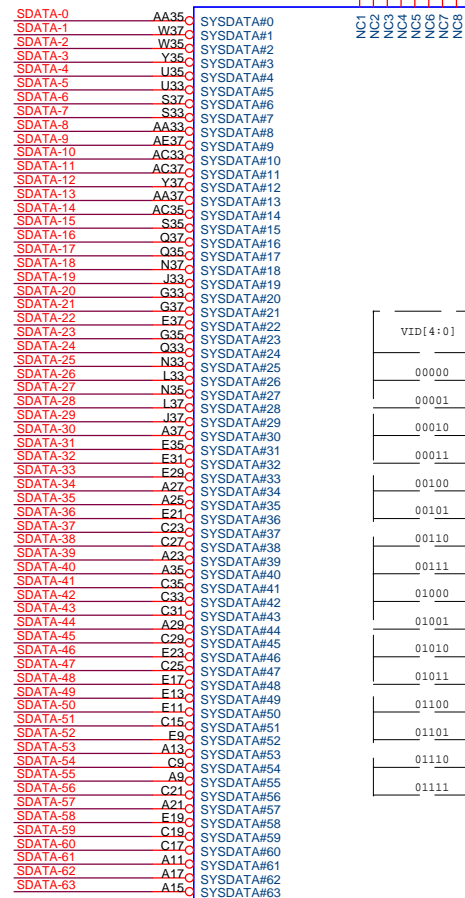
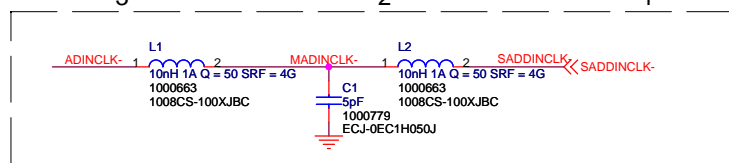
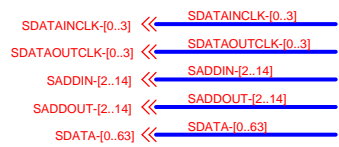

SOCKETA-1

VID[4:0]	VCC_CORE	VID[4:0]	VCC_CORE
00000	1.850	10000	1.450
00001	1.825	10001	1.425
00010	1.800	10010	1.400
00011	1.775	10011	1.375
00100	1.750	10100	1.350
00101	1.725	10101	1.325
00110	1.700	10110	1.300
00111	1.675	10111	1.275
01000	1.650	11000	1.250
01001	1.625	11001	1.225
01010	1.600	11010	1.200
01011	1.575	11011	1.175
01100	1.550	11100	1.150
01101	1.525	11101	1.125
01110	1.500	11110	1.100
01111	1.475	11111	NO CPU

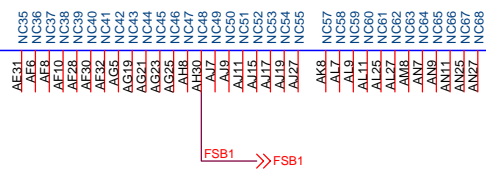
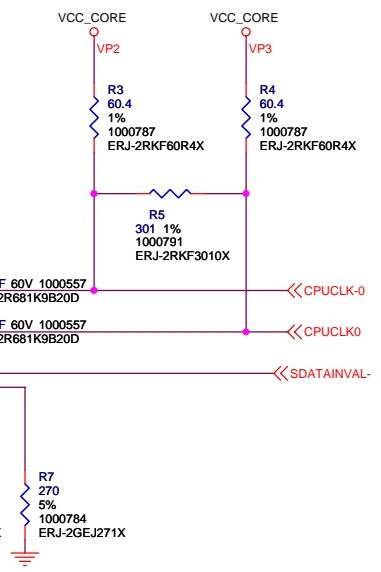
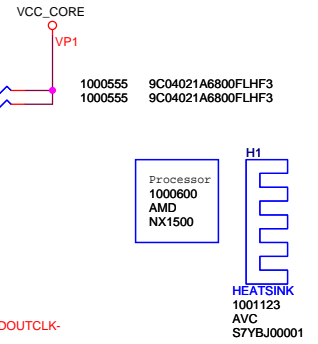
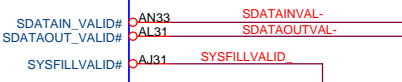
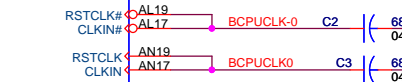
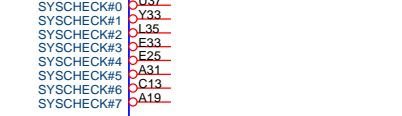
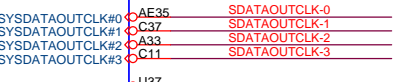
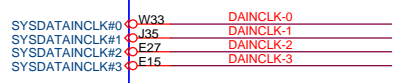
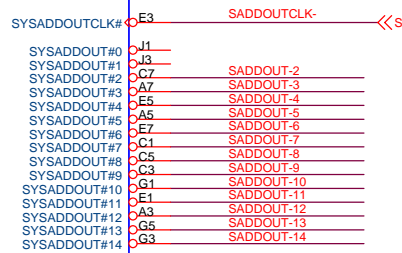
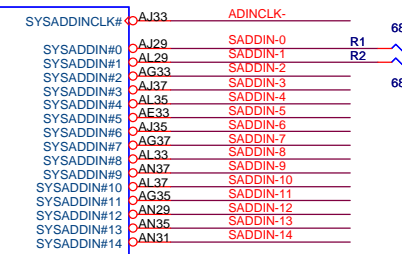

U1A 1000589 FOXCONN PZ46267-001-A

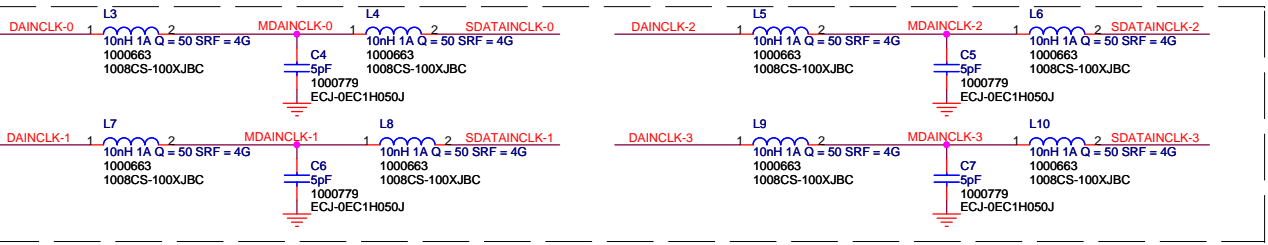

Design Create Date = Monday, December 22, 2003

		LOGIC PRODUCT DEVELOPMENT	411 WASHINGTON AVE. N MINNEAPOLIS, MN 55401 PHONE: (612) 672-9495 FAX: (612) 672-9489
Title SOCKETA-1		Size Custom	Number 1002124
Date Friday, January 13, 2006		Project	AMD Geode NX
		Sheet	6 Of 43

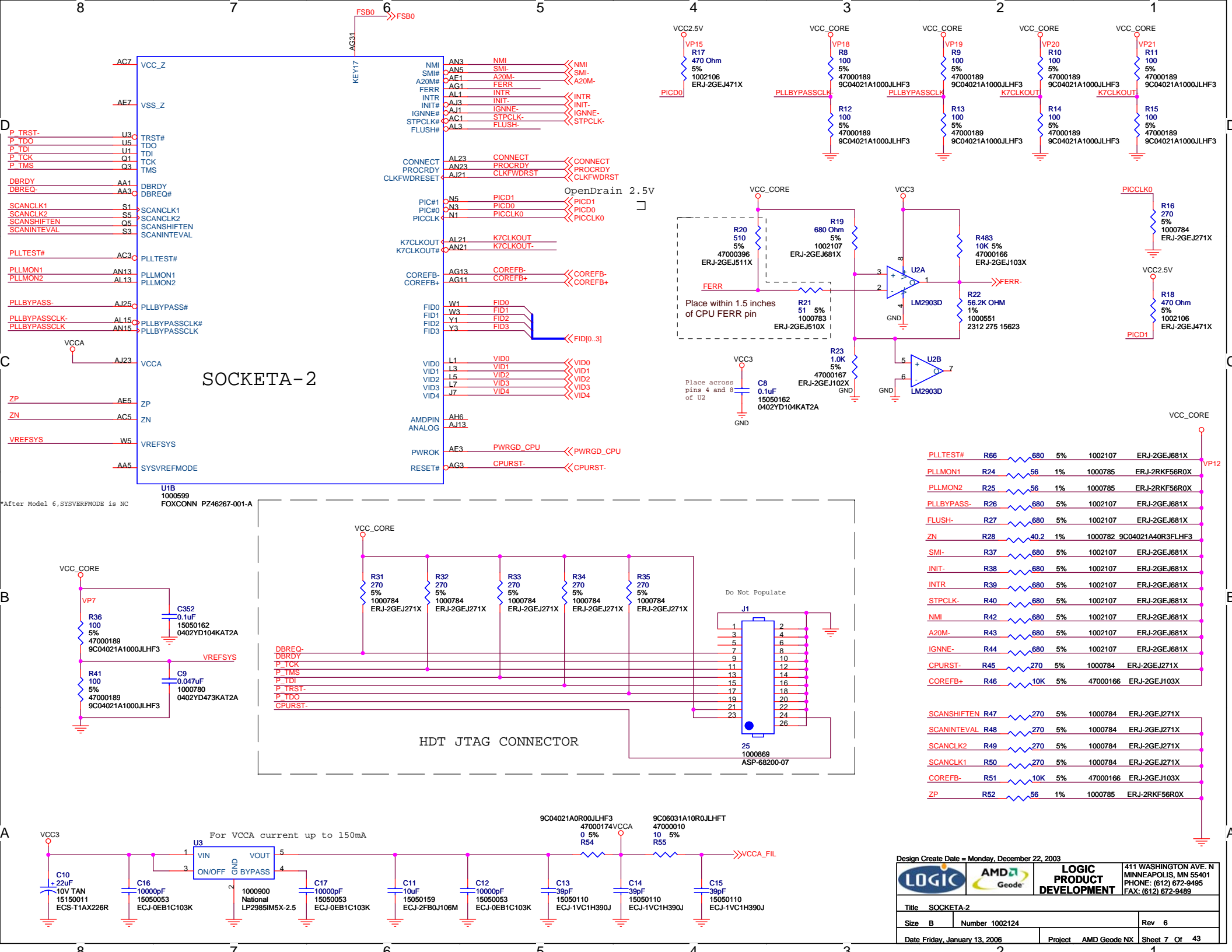

SOCKETA-2

PLLTEST#	R66	680	5%	1002107	ERJ-2GEJ681X	VP12
PLLMON1	R24	56	1%	1000785	ERJ-2RKF56R0X	
PLLMON2	R25	56	1%	1000785	ERJ-2RKF56R0X	
PLLBPASS-	R26	680	5%	1002107	ERJ-2GEJ681X	
FLUSH-	R27	680	5%	1002107	ERJ-2GEJ681X	
ZN	R28	40.2	1%	1000782	9C04021A40R3FLHF3	
SMI-	R37	680	5%	1002107	ERJ-2GEJ681X	
INIT-	R38	680	5%	1002107	ERJ-2GEJ681X	
INTR	R39	680	5%	1002107	ERJ-2GEJ681X	
STPCLK-	R40	680	5%	1002107	ERJ-2GEJ681X	
NMI	R42	680	5%	1002107	ERJ-2GEJ681X	
A20M-	R43	680	5%	1002107	ERJ-2GEJ681X	
IGNNE-	R44	680	5%	1002107	ERJ-2GEJ681X	
CPURST-	R45	270	5%	1000784	ERJ-2GEJ271X	
COREFB+	R46	10K	5%	47000166	ERJ-2GEJ103X	
SCANSHIFTEN	R47	270	5%	1000784	ERJ-2GEJ271X	
SCANINTEVAL	R48	270	5%	1000784	ERJ-2GEJ271X	
SCANCLK2	R49	270	5%	1000784	ERJ-2GEJ271X	
SCANCLK1	R50	270	5%	1000784	ERJ-2GEJ271X	
COREFB-	R51	10K	5%	47000166	ERJ-2GEJ103X	
ZP	R52	56	1%	1000785	ERJ-2RKF56R0X	

Design Create Date = Monday, December 22, 2003

LOGIC	AMD Geode	LOGIC PRODUCT DEVELOPMENT	411 WASHINGTON AVE. N MINNEAPOLIS, MN 55401 PHONE: (612) 672-9495 FAX: (612) 672-9489
Title SOCKETA-2		Rev 6	
Size B	Number 1002124	Project AMD Geode NX	
Date Friday, January 13, 2006	Sheet 7 Of 43		

*After Model 6, SYSVERPMODE is NC

VCC_CORE

VP22

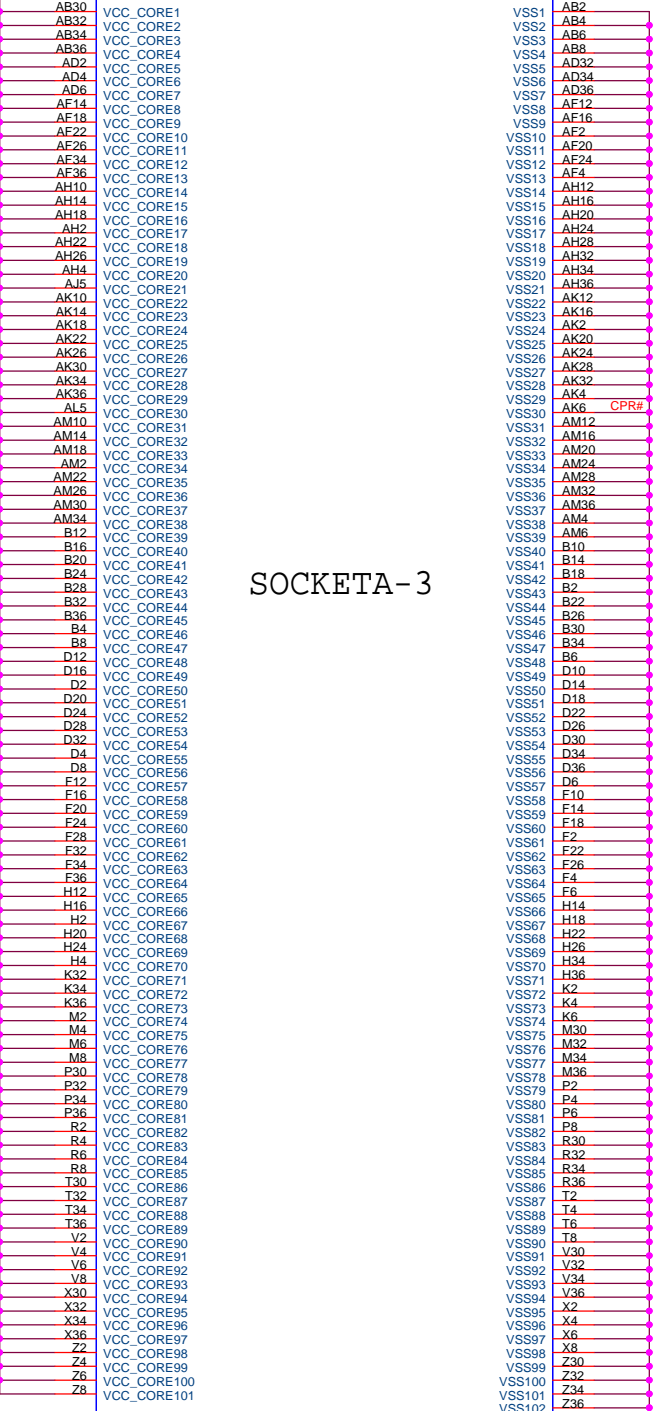

CPR#(AK6): CPU_PRESENCE# is connected to VSS on the processor package. If pulled-up on the motherboard, CPU_PRESENCE# may be used to detect the presence or absence of a processor.

SOCKET A-3

U1C
1000599
FOXCONN PZ46267-001-A

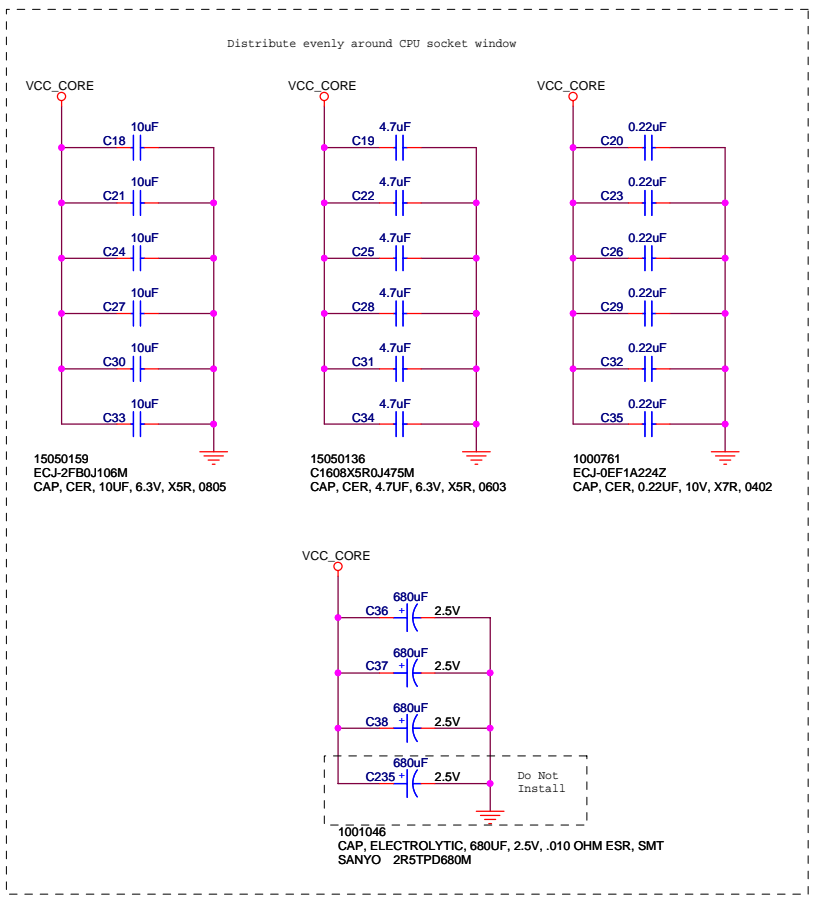

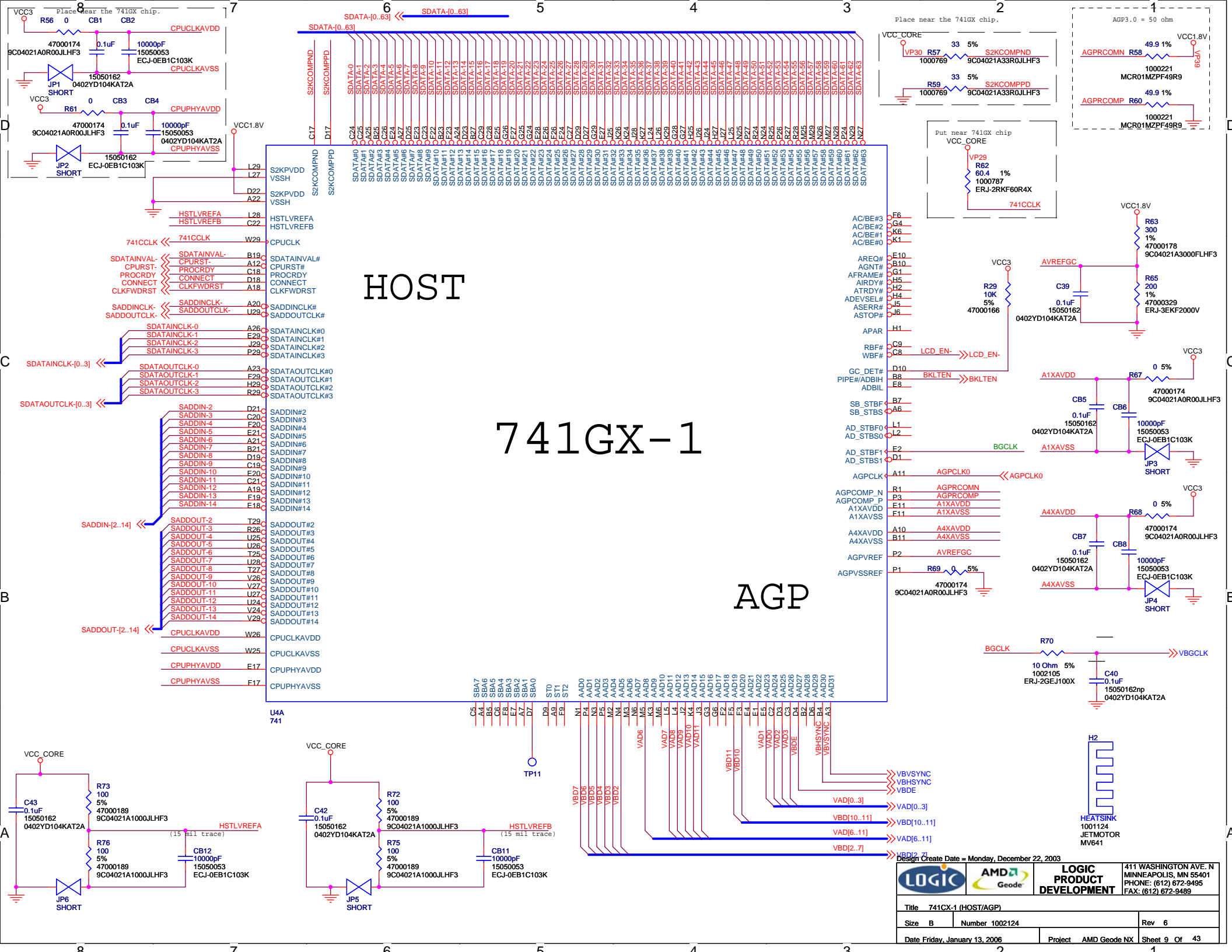

HOST

741GX-1

AGP

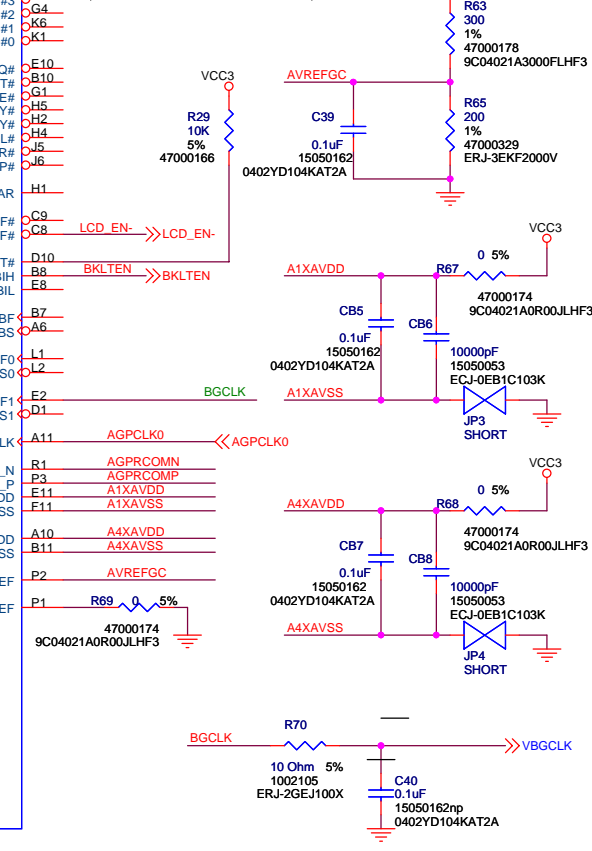
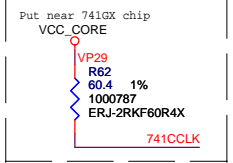
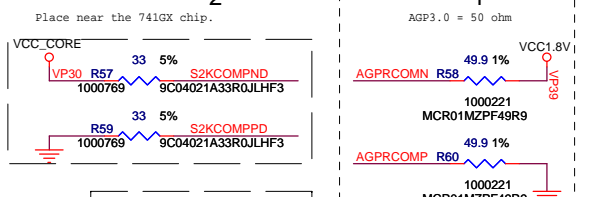

Design Create Date = Monday, December 22, 2003

		LOGIC PRODUCT DEVELOPMENT	411 WASHINGTON AVE. N MINNEAPOLIS, MN 55401 PHONE: (612) 672-9495 FAX: (612) 672-9489
Title 741CX-1 (HOST/AGP)		Number 1002124	Rev 6
Date Friday, January 13, 2006	Project AMD Geode NX	Sheet 9 Of 43	

MD4		1	/RMD4
MD7	RN1	2	/RMD7
MD1	10	3	/RMD1
MD6		4	/RMD6
DQS0		5	/RDQS0
DQM0	RN2	6	/RDQM0
MD3	10	7	/RMD3
MD5		8	/RMD5
MD9		9	/RMD9
MD2	RN3	10	/RMD2
MD13		11	/RMD13
MD10		12	/RMD10
MD8		13	/RMD8
MD12	RN4	14	/RMD12
DQS1	10	15	/RDQS1
DQM1		16	/RDQM1
MD11		17	/RMD11
MD14	RN5	18	/RMD14
MD15		19	/RMD15
MD9		20	/RMD9
MD20		21	/RMD20
MD21	RN6	22	/RMD21
MD17	10	23	/RMD17
MD16		24	/RMD16
MD28		25	/RMD28
MD29	RN7	26	/RMD29
MD25	10	27	/RMD25
DQS3		28	/RDQS3
MD31		29	/RMD31
MD30	RN8	30	/RMD30
MD7	10	31	/RMD7
MD26		32	/RMD26
MD36		33	/RMD36
MD32	RN9	34	/RMD32
MD37	10	35	/RMD37
MD33		36	/RMD33
MD38		37	/RMD38
MD35	RN10	38	/RMD35
MD45	10	39	/RMD45
MD44		40	/RMD44
DQS4		41	/RDQS4
DQM4	RN11	42	/RDQM4
MD34	10	43	/RMD34
MD39		44	/RMD39
DQS5		45	/RDQS5
DQM5	RN12	46	/RDQM5
MD40	10	47	/RMD40
MD42		48	/RMD42
MD47		49	/RMD47
MD43	RN13	50	/RMD43
MD52	10	51	/RMD52
MD54		52	/RMD54
MD48		53	/RMD48
MD55	RN14	54	/RMD55
DQM6	10	55	/RDQM6
DQS6		56	/RDQS6
MD50		57	/RMD50
MD49	RN15	58	/RMD49
MD51	10	59	/RMD51
MD53		60	/RMD53
MD62		61	/RMD62
MD61	RN16	62	/RMD61
MD60	10	63	/RMD60
MD57		64	/RMD57
DQM7		65	/RDQM7
DQS7	RN17	66	/RDQS7
MD56	10	67	/RMD56
MD58		68	/RMD58
DQS2		69	/RDQS2
DQM2	RN18	70	/RDQM2
MD18	10	71	/RMD18
MD19		72	/RMD19
MD23	R474	73	/RMD23
MD22	R475	74	/RMD22
MD24	R105	75	/RMD24
DQM3	R106	76	/RDQM3
MD63	R107	77	/RMD63
MD59	R108	78	/RMD59
MD41	R98	79	/RMD41
MD46	R99	80	/RMD46

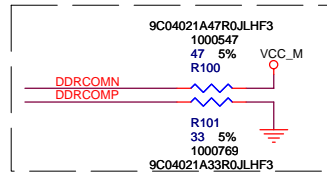

MAA15	0	R77	/RMAA15
MAA14	0	R78	/RMAA14
MAA13	0	R79	/RMAA13
MAA9	0	R80	/RMAA9
MAA4	0	R81	/RMAA4
MAA6	0	R83	/RMAA6
MAA5	0	R84	/RMAA5
MAA0	0	R86	/RMAA0
MAA1	0	R87	/RMAA1
MAA2	0	R88	/RMAA2
MAA3	0	R89	/RMAA3
MAA11	0	R91	/RMAA11
MAA12	0	R92	/RMAA12
MAA10	0	R93	/RMAA10
MAA7	0	R472	/RMAA7
MAA8	0	R473	/RMAA8
RASA-	0	R90	/RRASA-
MWA-	0	R94	/RMWA-
CASA-	0	R95	/RCASA-
CSA-0	0	R96	/RCSA-0
CSA-1	0	R97	/RCSA-1

1002105	ERJ-2GEJ100X
1002105	ERJ-2GEJ100X
1002105	ERJ-2GEJ100X
1002105	ERJ-2GEJ100X
1002105	ERJ-2GEJ100X
1002105	ERJ-2GEJ100X
1002105	ERJ-2GEJ100X
1002105	ERJ-2GEJ100X
1002105	ERJ-2GEJ100X
1002105	ERJ-2GEJ100X

/RMD0	AF29	MD0
/RMD1	AC25	MD1
/RMD2	AF28	MD2
/RMD3	AE28	MD3
/RMD4	AB24	MD4
/RMD5	AE27	MD5
/RMD6	AD26	MD6
/RMD7	AC26	MD7
/RDQM0	AD27	DQM0
/RDQS0	AD29	DQS0/CSB#0
/RMD8	AG27	MD8
/RMD9	AF25	MD9
/RMD10	AH28	MD10
/RMD11	AG26	MD11
/RMD12	AH27	MD12
/RMD13	AG29	MD13
/RMD14	AJ26	MD14
/RMD15	AE25	MD15
/RDQM1	AE26	DQM1
/RDQS1	AJ27	DQS1/CSB#1
/RMD16	AG24	MD16
/RMD17	AE24	MD17
/RMD18	AE23	MD18
/RMD19	AG23	MD19
/RMD20	AH25	MD20
/RMD21	AD24	MD21
/RMD22	AH22	MD22
/RMD23	AJ23	MD23
/RDQM2	AD23	DQM2
/RDQS2	AH24	DQS2/CSB#2
/RMD24	AH24	MD24
/RMD25	AH19	MD25
/RMD26	AE18	MD26
/RMD27	AD18	MD27
/RMD28	AG20	MD28
/RMD29	AJ20	MD29
/RMD30	AE19	MD30
/RMD31	AE19	MD31
/RDQM3	AE20	DQM3
/RDQS3	AJ19	DQS3/CSB#3
/RMD32	AE15	MD32
/RMD33	AF14	MD33
/RMD34	AJ14	MD34
/RMD35	AE13	MD35
/RMD36	AE16	MD36
/RMD37	AD16	MD37
/RMD38	AE13	MD38
/RMD39	AG14	MD39
/RDQM4	AG15	DQM4
/RDQS4	AH15	DQS4/CSB#4
/RMD40	AH9	MD40
/RMD41	AF10	MD41
/RMD42	AG9	MD42
/RMD43	AG8	MD43
/RMD44	AE10	MD44
/RMD45	AD9	MD45
/RMD46	AE9	MD46
/RMD47	AH8	MD47
/RDQM5	AH10	DQM5
/RDQS5	AE10	DQS5/CSB#5
/RMD48	AE7	MD48
/RMD49	AJ6	MD49
/RMD50	AG7	MD50
/RMD51	AH6	MD51
/RMD52	AE8	MD52
/RMD53	AJ5	MD53
/RMD54	AD8	MD54
/RMD55	AE6	MD55
/RDQM6	AD7	DQM6
/RDQS6	AH7	DQS6/CSB#6
/RMD56	AG4	MD56
/RMD57	AG5	MD57
/RMD58	AJ3	MD58
/RMD59	AH2	MD59
/RMD60	AH5	MD60
/RMD61	AE5	MD61
/RMD62	AE6	MD62
/RMD63	AH3	MD63
/RDQM7	AE4	DQM7
/RDQS7	AH4	DQS7/CSB#7

741GX-2

MAA0	AG17	/RMAA0
MAA1	AE17	/RMAA1
MAA2	AD17	/RMAA2
MAA3	AH18	/RMAA3
MAA4	AG18	/RMAA4
MAA5	AJ22	/RMAA5
MAA6	AE21	/RMAA6
MAA7	AD21	/RMAA7
MAA8	AE21	/RMAA8
MAA9	AE22	/RMAA9
MAA10	AJ17	/RMAA10
MAA11	AD14	/RMAA11
MAA12	AE16	/RMAA12
MAA13	AE22	/RMAA13
MAA14	AD20	/RMAA14
MAA15	AD11	/RMAA15
RAMWA#	AH13	/RMWA-
SRASA#	AJ13	/RRASA-
SCASA#	AH12	/RCASA-
CSA#0	AE12	/RCSA-0
CSA#1	AD12	/RCSA-1
CSA#2	AG12	/RCSA-2
CSA#3	AJ11	/RCSA-3
CSA#4	AG11	/RCSA-4
CSA#5	AF11	/RCSA-5
DDRREFA	AJ25	DDRREFA
DDRREFB	AJ8	DDRREFB
DLLAVDD	Y29	DLLAVDD
DLLAVSS	Y28	DLLAVSS
SDRCLKI	AH16	SDRCLKI
FWSDCLKO	AJ16	FWSDCLKO
DDRVA	W28	DDRVA
DDRVA	W27	DDRVA
CKE0	AF1	CKE0
CKE1	AG1	CKE1
CKE2	AE2	CKE2
CKE3	AE3	CKE3
CKE4	AF2	CKE4
CKE5	AE1	CKE5
S3AUXSW#	AD5	S3AUXSW#
DDRCOMP_P	AG2	DDRCOMP
DDRCOMP_N	AF3	DDRCOMP

U4B
1000596
Silicon Integrated Systems SIS741CX

Put near 741GX chip.

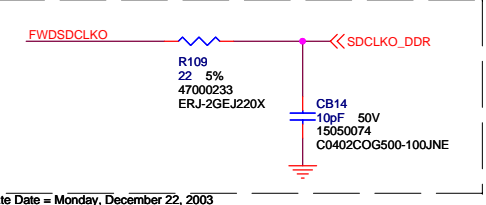
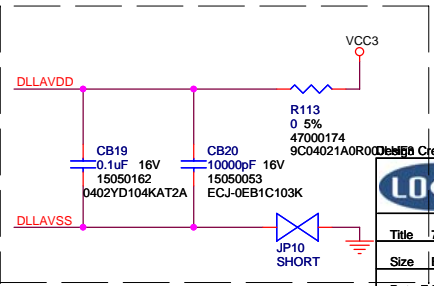
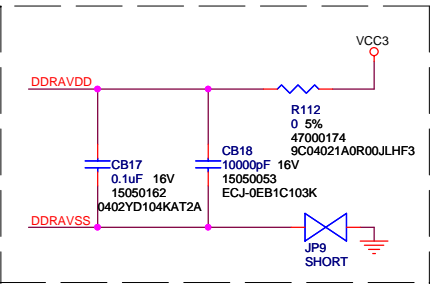
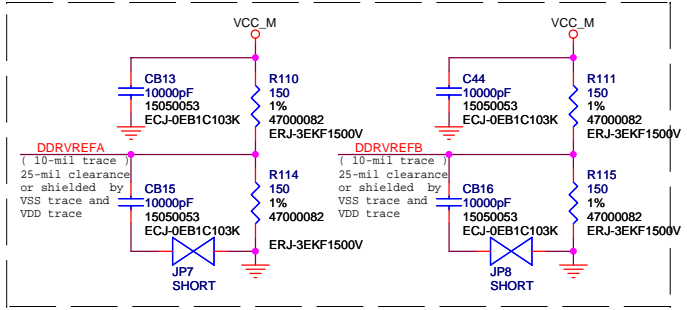

LOGIC PRODUCT DEVELOPMENT

411 WASHINGTON AVE. N
MINNEAPOLIS, MN 55401
PHONE: (612) 672-9495
FAX: (612) 672-9489

Title: 741CX-2 (MEMORY for DDR)

Size: B Number: 1002124 Rev: 6

Date: Friday, January 13, 2006 Project: AMD Geode NX Sheet: 10 Of 43

		Enable	Disable
RSYNC	INTA	1	0
LSYNC	Panel Link	1	0
CSYNC	VB	1	0

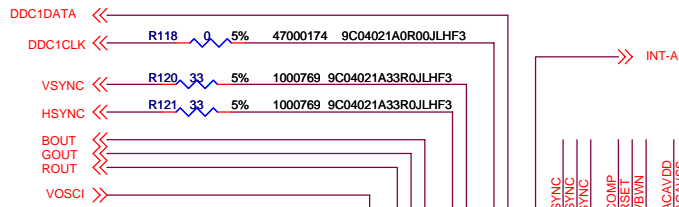

The differences between the traces of MuTIOL Strokes and Data should be smaller than 0.05'

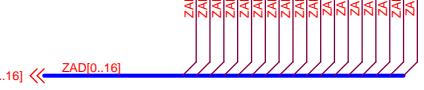
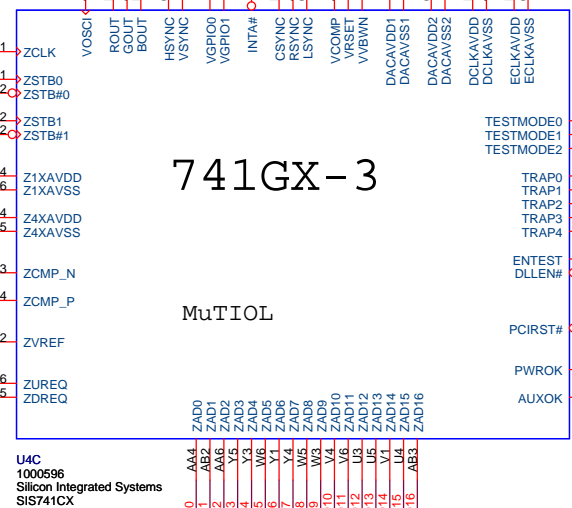
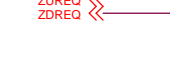
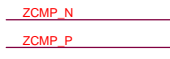
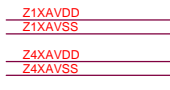

Should not change layer

Place near 741GX chip.

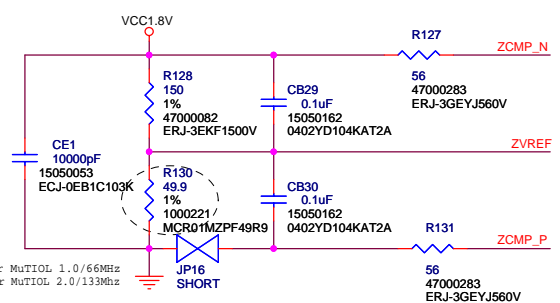
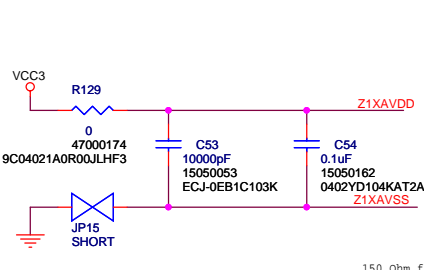
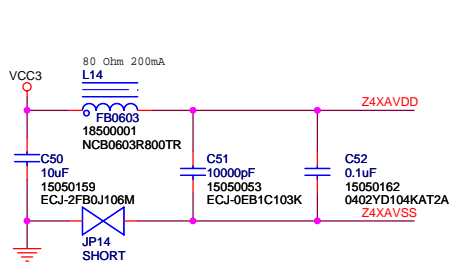

150 Ohm for MuTIOL 1.0/66MHz
49.9 Ohm for MuTIOL 2.0/133MHz

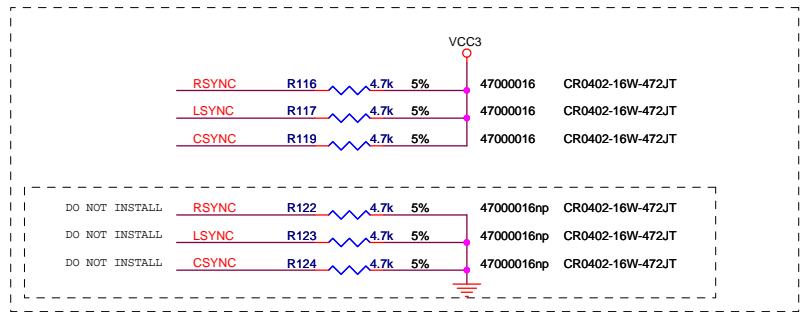

DO NOT INSTALL RSYNC R122 4.7k 5% 47000016np CR0402-16W-472JT
DO NOT INSTALL LSYNC R123 4.7k 5% 47000016np CR0402-16W-472JT
DO NOT INSTALL CSYNC R124 4.7k 5% 47000016np CR0402-16W-472JT

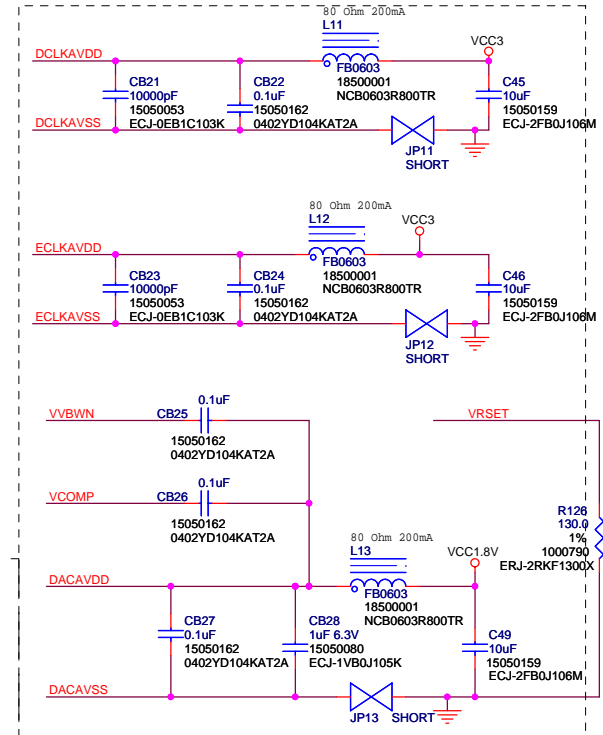

Design Create Date = Monday, December 22, 2003

		LOGIC PRODUCT DEVELOPMENT	411 WASHINGTON AVE. N MINNEAPOLIS, MN 55401 PHONE: (612) 672-9495 FAX: (612) 672-9489
Title 741CX-3 (MUTIOL/VGA/Others)			Rev 6
Size Custom	Number 1002124		
Date Friday, January 13, 2006	Project AMD Geode NX	Sheet 11 Of 43	

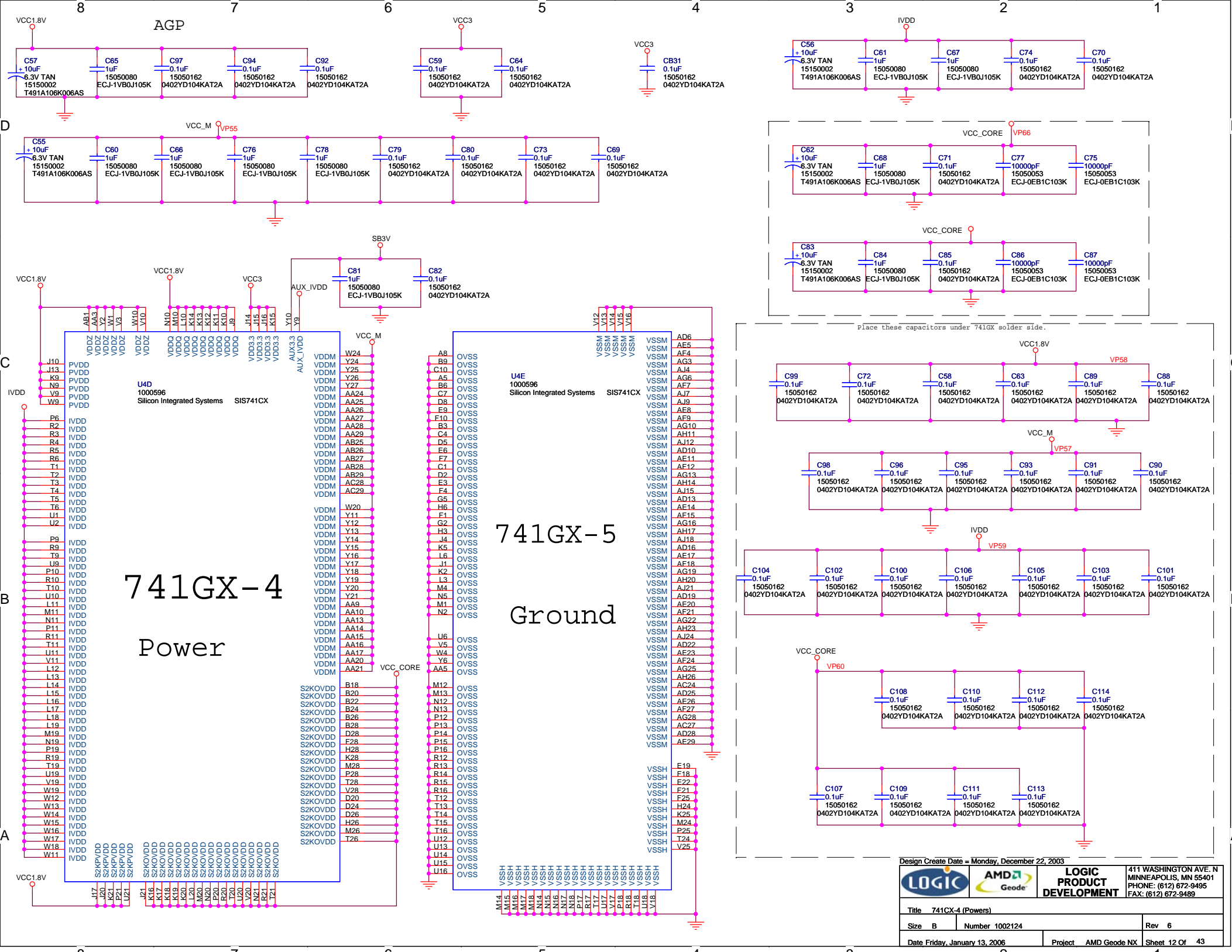

Design Create Date = Monday, December 22, 2003	
LOGIC PRODUCT DEVELOPMENT	
411 WASHINGTON AVE. N MINNEAPOLIS, MN 55401 PHONE: (612) 672-9495 FAX: (612) 672-9489	
Title 741CX-4 (Powers)	
Size B	Number 1002124
Rev 6	
Date Friday, January 13, 2006	Project AMD Geode NX
Sheet 12	Of 43

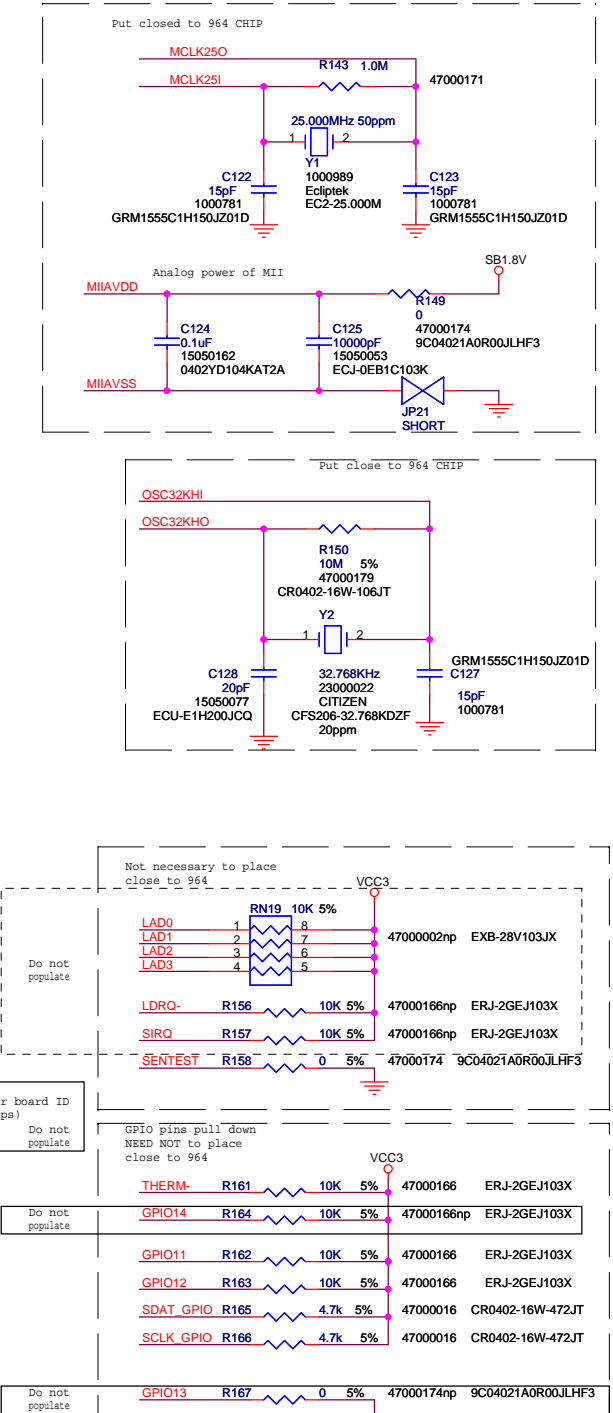
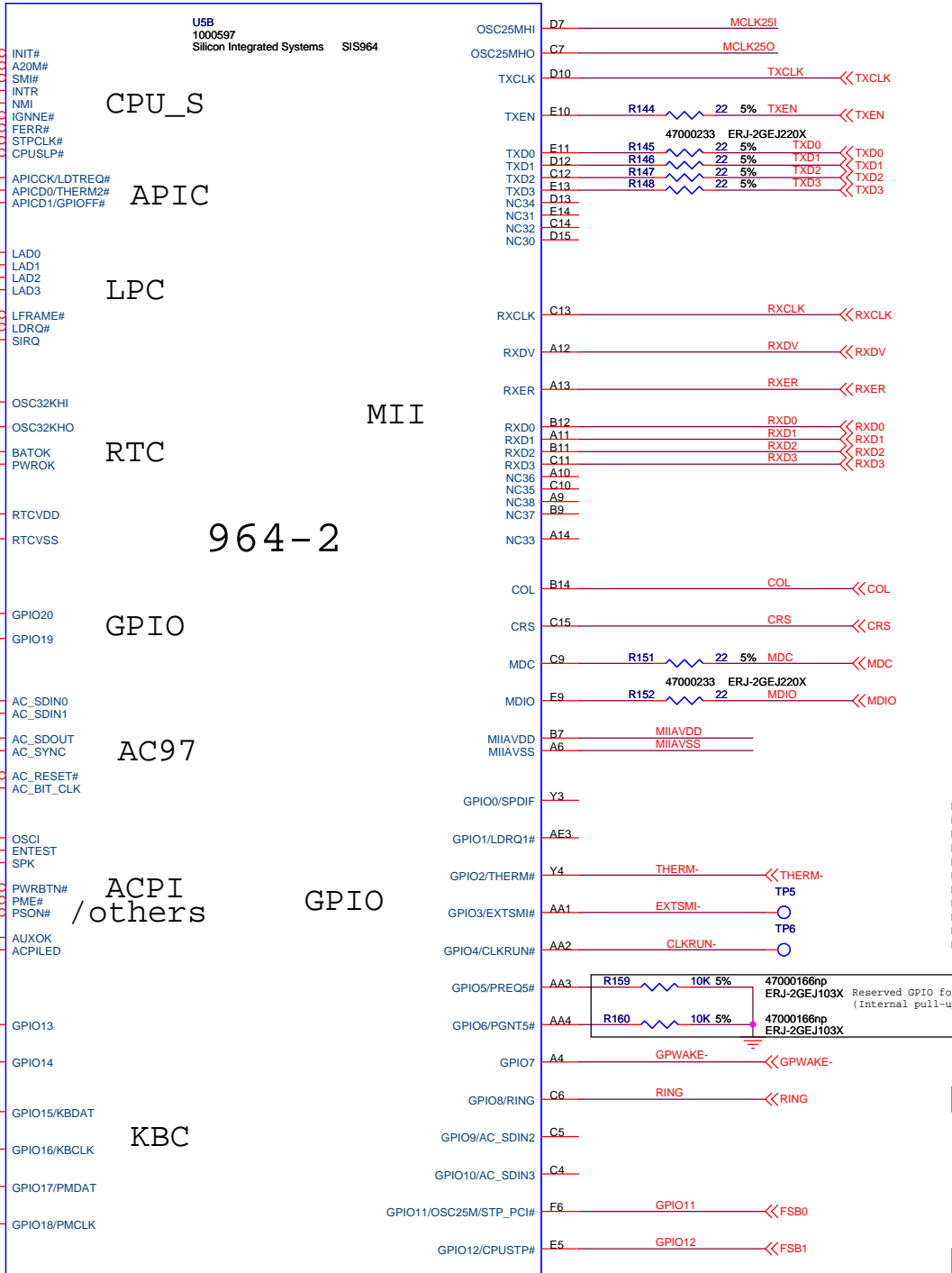
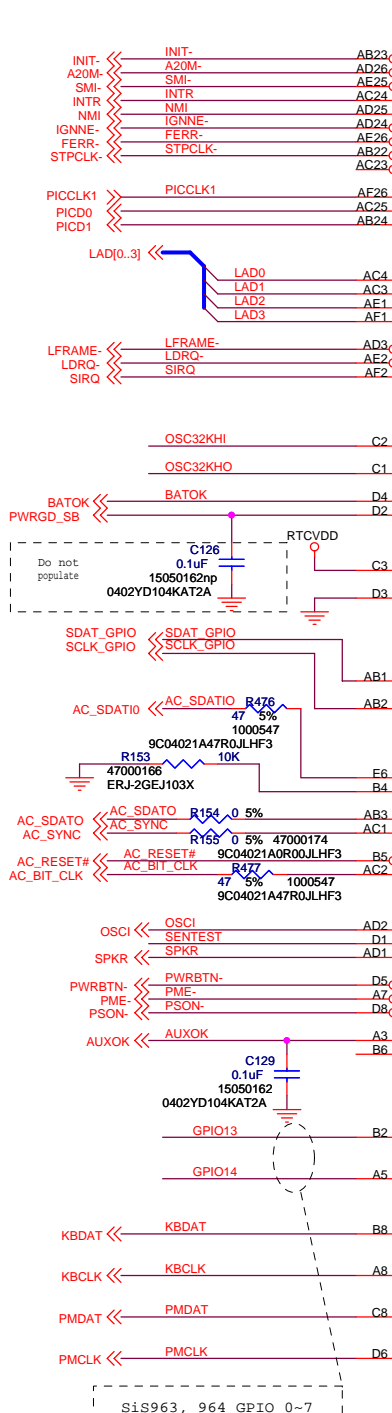

Design Create Date = Monday, December 22, 2003

		LOGIC PRODUCT DEVELOPMENT	411 WASHINGTON AVE. N MINNEAPOLIS, MN 55401 PHONE: (612) 672-9495 FAX: (612) 672-9489
Title 964-2 (LPC/MII/CPU/GPIO)			Rev 6
Size B	Number 1002124		
Date Friday, January 13, 2006	Project AMD Geode NX	Sheet 14 Of 43	

Potentially save cost of crystal by putting in resistor divider in R469 and replace C350 with other resistor to knock down 3.3V clock to 1.8v input. Place R469 Near Clock chip source. Use R471 to provide T to avoid a trace stub

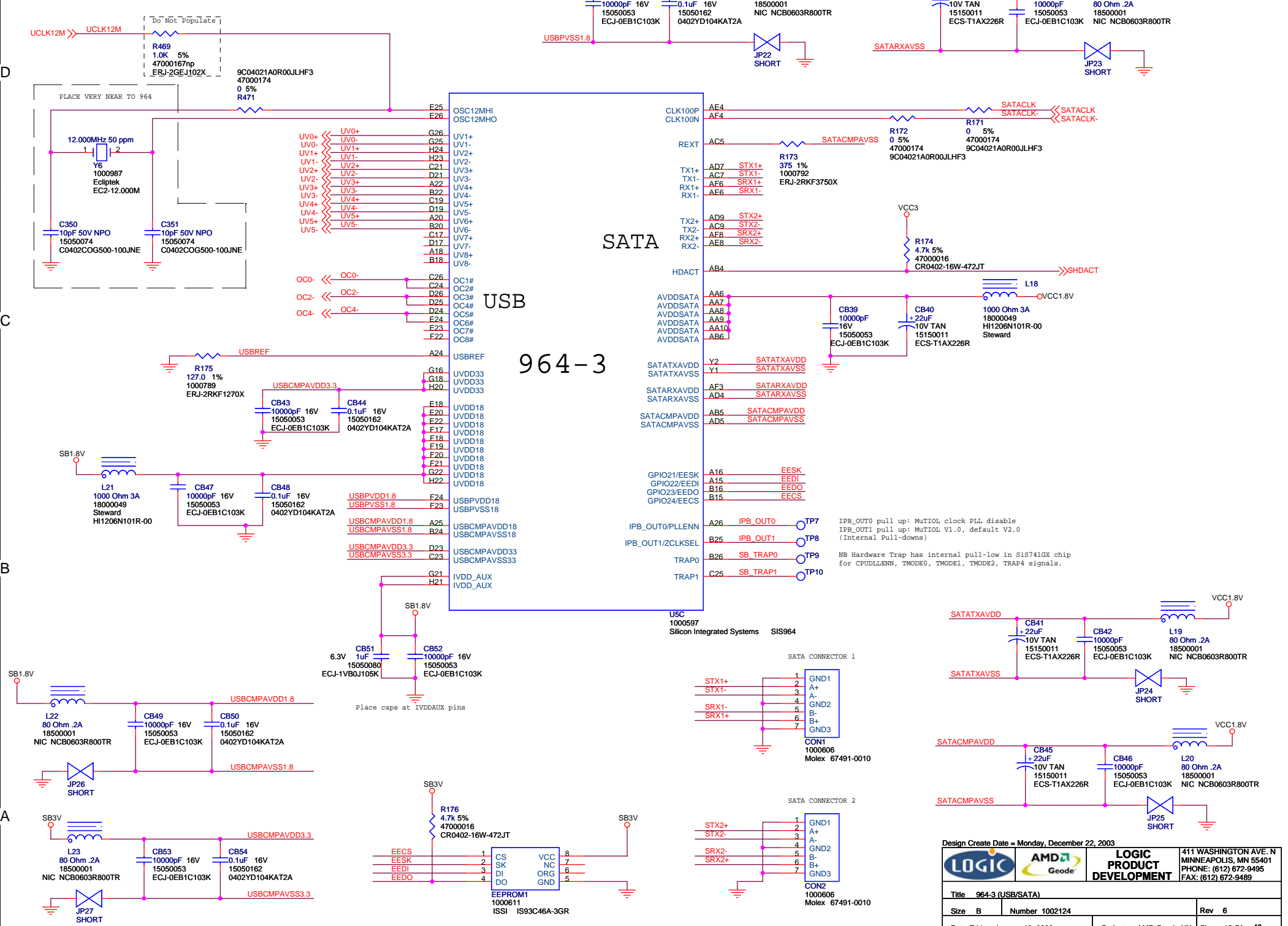

Design Create Date = Monday, December 22, 2003

		LOGIC PRODUCT DEVELOPMENT	411 WASHINGTON AVE. N MINNEAPOLIS, MN 55401 PHONE: (612) 672-9495 FAX: (612) 672-9489
Title 964-3 (USB/SATA)		Number 1002124	Rev 6
Date Friday, January 13, 2006	Project AMD Geode NX	Sheet 15 Of 43	

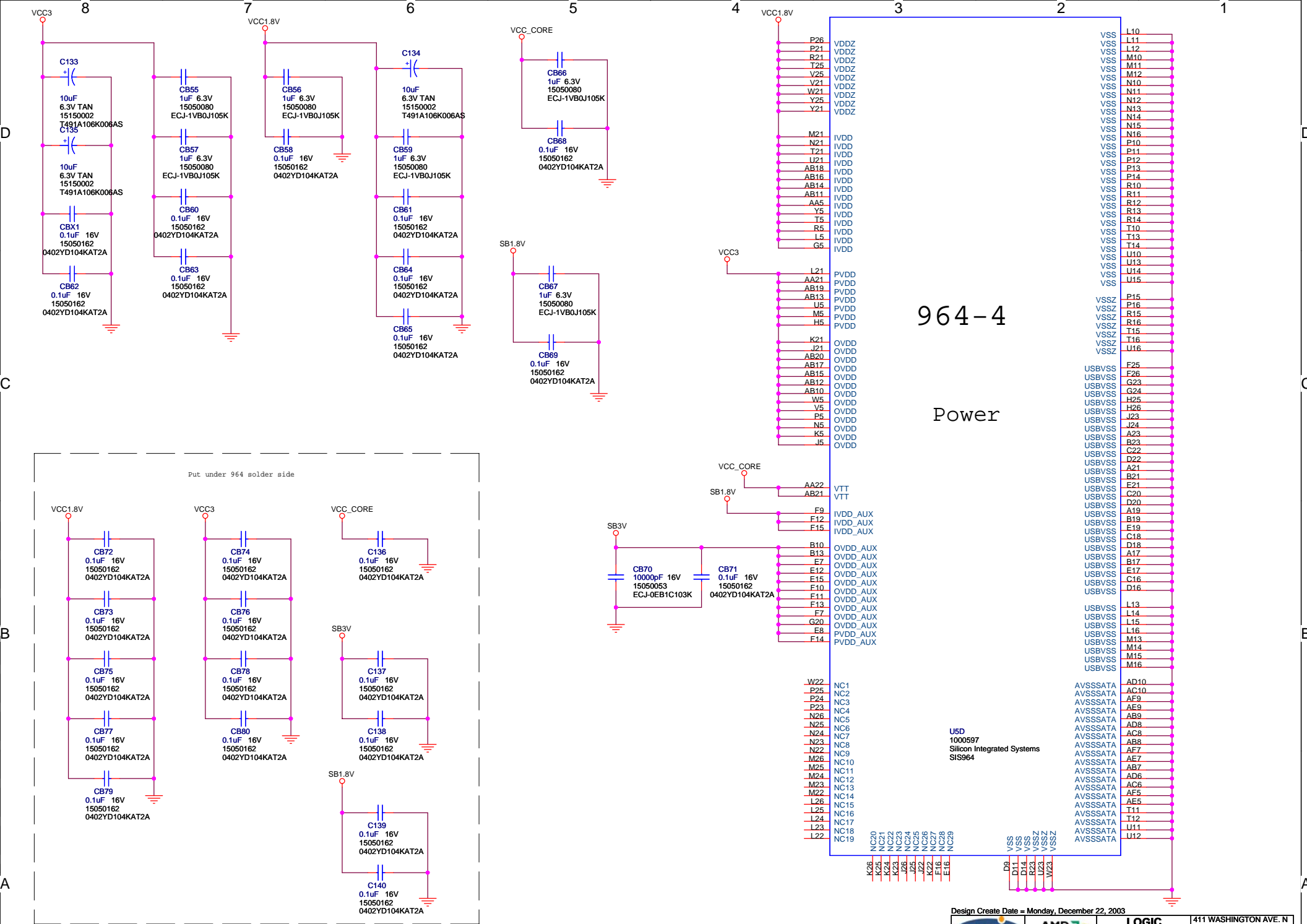

964-4
Power

Design Create Date = Monday, December 22, 2003

				LOGIC PRODUCT DEVELOPMENT		411 WASHINGTON AVE. N MINNEAPOLIS, MN 55401 PHONE: (612) 672-9495 FAX: (612) 672-9489	
Title 964-4 (Power)							
Size B	Number 1002124						Rev 6
Date Friday, January 13, 2006		Project AMD Geode NX		Sheet 16 Of 43			

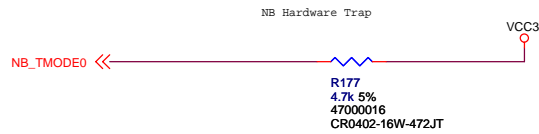

NB Hardware Trap has internal pull-low in SiS741GX chip for CPUPLLNN, TMODE0, TMODE1, TMODE2, TRAP4 signals.

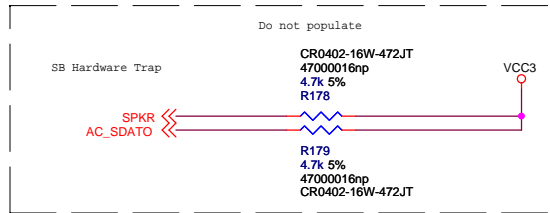

SPKR: First Flash Memory cycle type selection
 0: LPC Memory Cycle
 1: Firmware Memory Cycle

	0	1	Default
SDATO(Trap from)	ROM	PCI_AD	0
OC4-(SB debug mode)	enable	disable	1

NB Hardware Trap Table

SW1 pin		Description	ON/1	OFF/0	Default
S1	CPUDLENN	CPUDLK SDCLK PLL/DLL Circuit Enable	DISABLE	ENABLE	OFF
S2	TMODE0	TV Type Select	NPSC	PAL	OFF
S3	TMODE1	MuTIOL (ASL) Initialize Mode	DISABLE	ENABLE	OFF
S4	TMODE2	741GX Debug Mode Selection	ENABLE	DISABLE	OFF
S5	TRAP4	MuTIOL Type (Version 1 , 2)	Ver. 1	Ver. 2	OFF

South Bridge Trap is on page 15.

NB Hardware Trap has internal pull-low in SiS741GX chip FOR TRAP[0..3].

	(FID3)	(FID2)	(FID1)	(FID0)
11.0	0	0	0	0
11.5	0	0	0	1
12.0	0	0	1	0
12.5	0	0	1	1
5.0	0	1	0	0
5.5	0	1	0	1
6.0	0	1	1	0
6.5	0	1	1	1
7.0	1	0	0	0
7.5	1	0	0	1
8.0	1	0	1	0
8.5	1	0	1	1
9.0	1	1	0	0
9.5	1	1	0	1
10.0	1	1	1	0
10.5	1	1	1	1

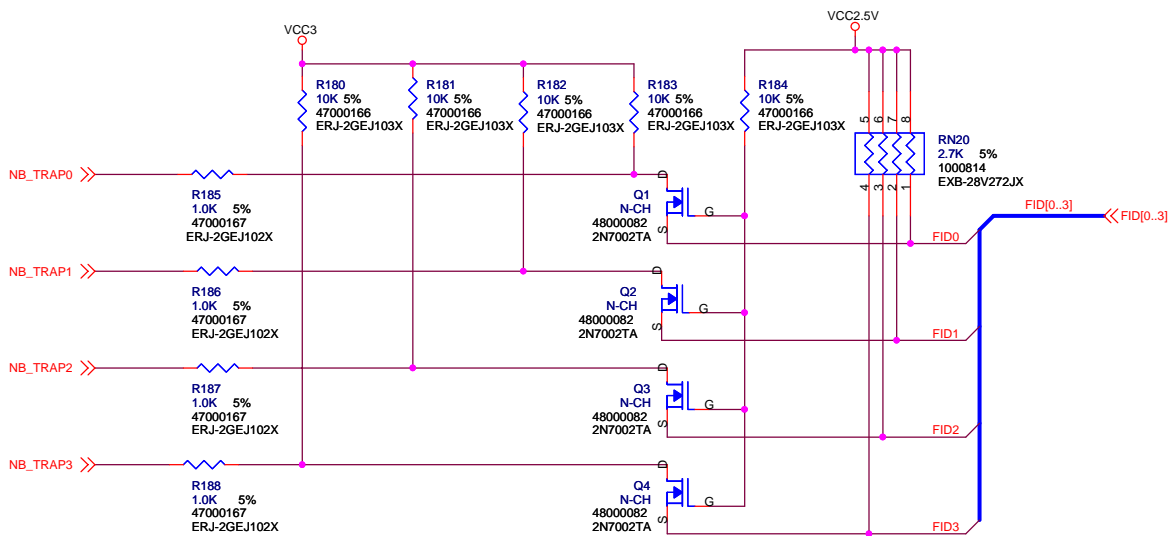

Design Create Date = Monday, December 22, 2003

		LOGIC PRODUCT DEVELOPMENT	411 WASHINGTON AVE. N MINNEAPOLIS, MN 55401 PHONE: (612) 672-9495 FAX: (612) 672-9489
Title Hardware Trap(For 964)			
Size B	Number 1002124	Project AMD Geode NX	Rev 6
Date Friday, January 13, 2006			Sheet 17 Of 43

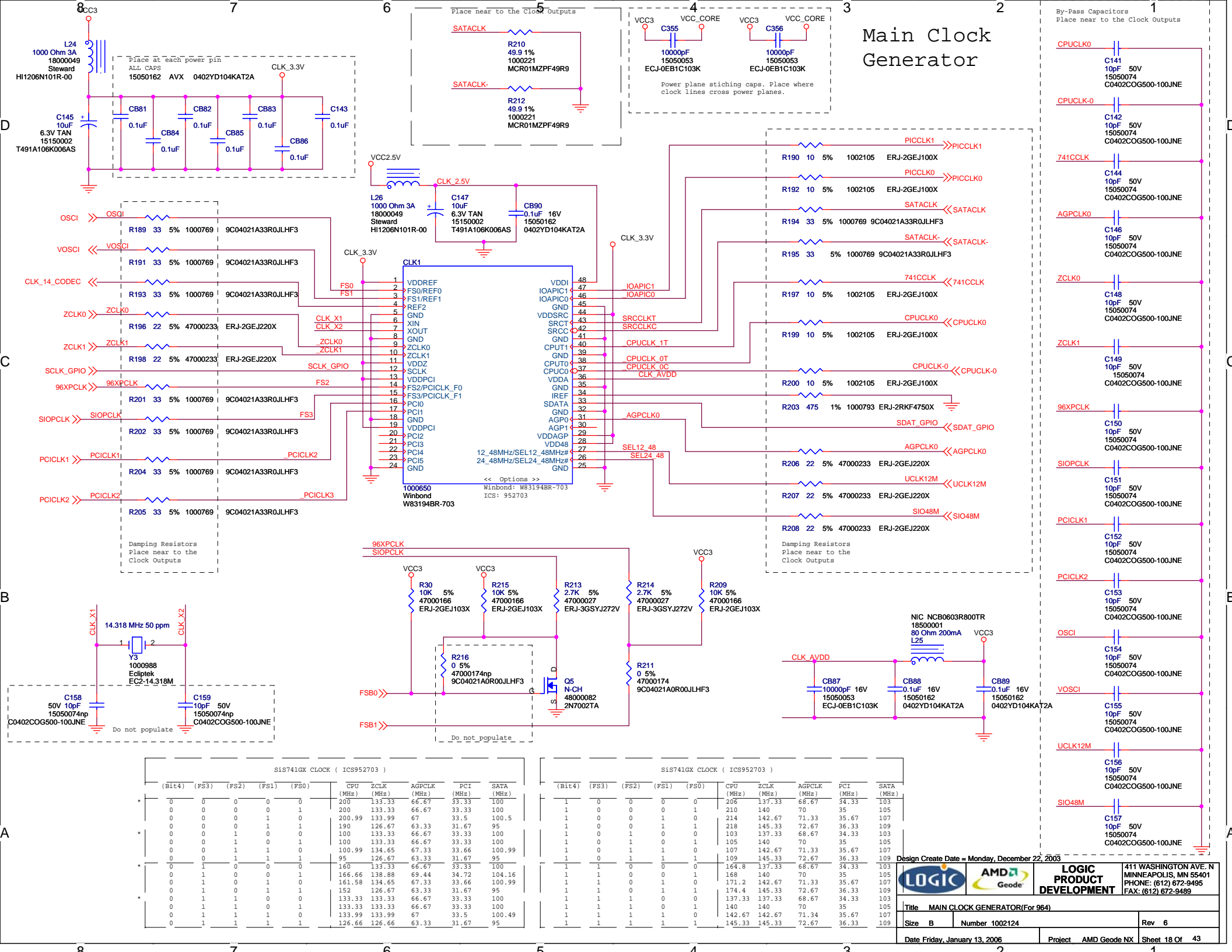

Main Clock Generator

D

C

B

A

Damping Resistors
Place near to the
Clock Outputs

Damping Resistors
Place near to the
Clock Outputs

Do not populate

Do not populate

SIS741GX CLOCK (ICS952703)												
(Bit4)	(FS3)	(FS2)	(FS1)	(FS0)	CPU (MHz)	ZCLK (MHz)	AGPCLK (MHz)	PCI (MHz)	SATA (MHz)			
0	0	0	0	0	200	137.33	66.67	33.33	100			
0	0	0	0	1	200	133.33	66.67	33.33	100			
0	0	0	1	0	200.99	133.99	67	33.5	100.5			
0	0	0	1	1	190	126.67	63.33	31.67	95			
0	0	1	0	0	100	133.33	66.67	33.33	100			
0	0	1	0	1	100	133.33	66.67	33.33	100			
0	0	1	1	0	100	133.33	66.67	33.33	100			
0	0	1	1	1	100.99	134.65	67.33	33.66	100.99			
0	0	1	1	1	95	126.67	63.33	31.67	95			
0	1	0	0	0	160	137.33	66.67	33.33	100			
0	1	0	0	1	166.66	138.88	69.44	34.72	104.16			
0	1	0	1	0	161.58	134.65	67.33	33.66	100.99			
0	1	0	1	1	152	126.67	63.33	31.67	95			
0	1	1	0	0	133.33	133.33	66.67	33.33	100			
0	1	1	0	1	133.33	133.33	66.67	33.33	100			
0	1	1	1	0	133.99	133.99	67	33.5	100.49			
0	1	1	1	1	126.66	126.66	63.33	31.67	95			

SIS741GX CLOCK (ICS952703)												
(Bit4)	(FS3)	(FS2)	(FS1)	(FS0)	CPU (MHz)	ZCLK (MHz)	AGPCLK (MHz)	PCI (MHz)	SATA (MHz)			
1	0	0	0	0	206	137.33	68.67	34.33	103			
1	0	0	0	1	210	140	70	35	105			
1	0	0	1	0	214	142.67	71.33	35.67	107			
1	0	0	1	1	218	145.33	72.67	36.33	109			
1	0	1	0	0	103	137.33	68.67	34.33	103			
1	0	1	0	1	105	140	70	35	105			
1	0	1	1	0	107	142.67	71.33	35.67	107			
1	0	1	1	1	109	145.33	72.67	36.33	109			
1	1	0	0	0	164.8	137.33	68.67	34.33	103			
1	1	0	0	1	168	140	70	35	105			
1	1	0	1	0	171.2	142.67	71.33	35.67	107			
1	1	0	1	1	174.4	145.33	72.67	36.33	109			
1	1	1	0	0	137.33	137.33	68.67	34.33	103			
1	1	1	0	1	140	140	70	35	105			
1	1	1	1	0	142.67	142.67	71.34	35.67	107			
1	1	1	1	1	145.33	145.33	72.67	36.33	109			

Design Create Date = Monday, December 22, 2003

		LOGIC PRODUCT DEVELOPMENT	411 WASHINGTON AVE. N MINNEAPOLIS, MN 55401 PHONE: (612) 672-9495 FAX: (612) 672-9489
			Title MAIN CLOCK GENERATOR(FOR64)

Size B	Number 1002124	Rev 6
Date Friday, January 13, 2006	Project AMD Geode NX	Sheet 18 Of 43

SDRAM Clock Buffer

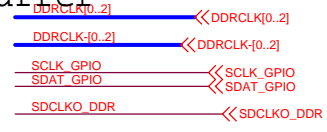

1. Winbond W83176R-732
2. ICS: ICS93732
3. Hitachi: DCDV852
4. Realtek: RTM 680-629

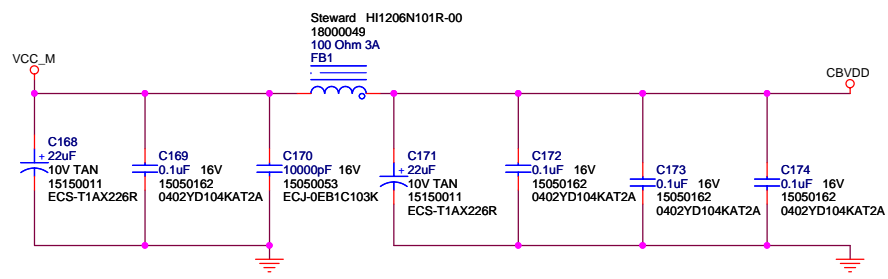
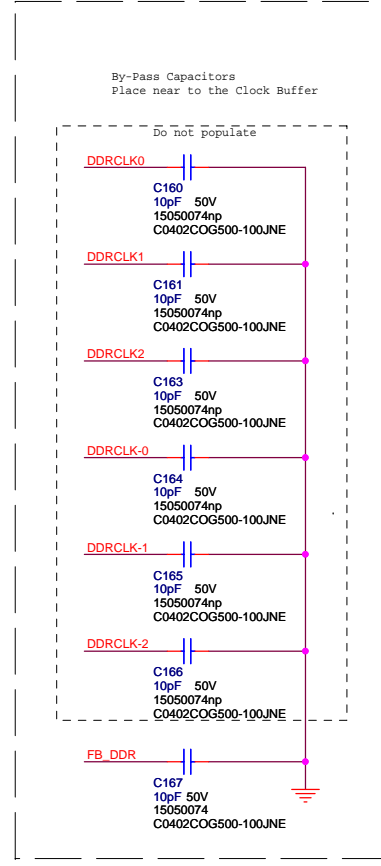
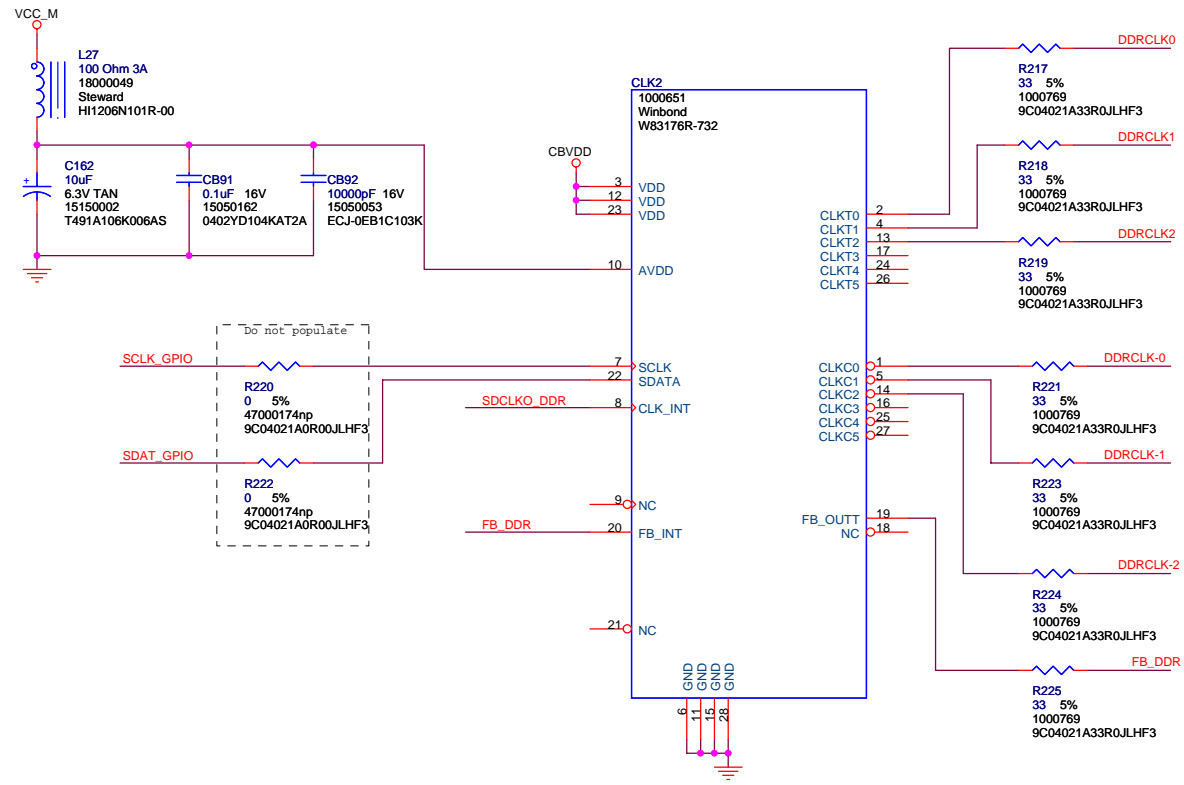

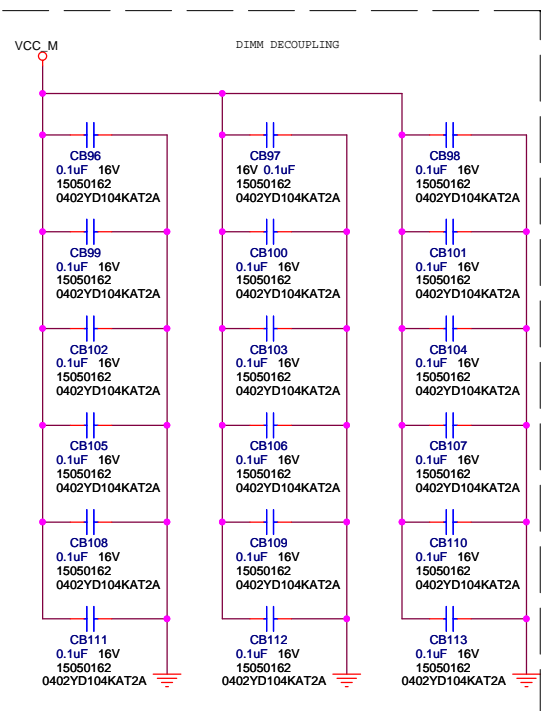
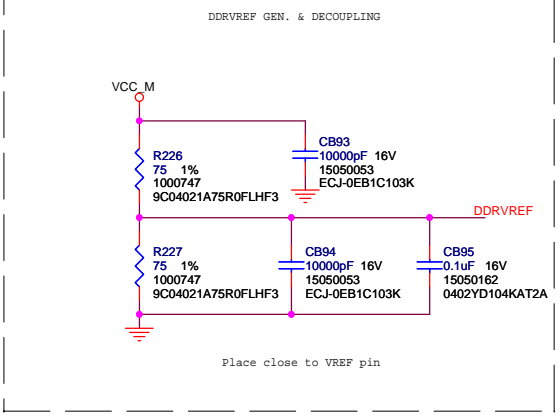
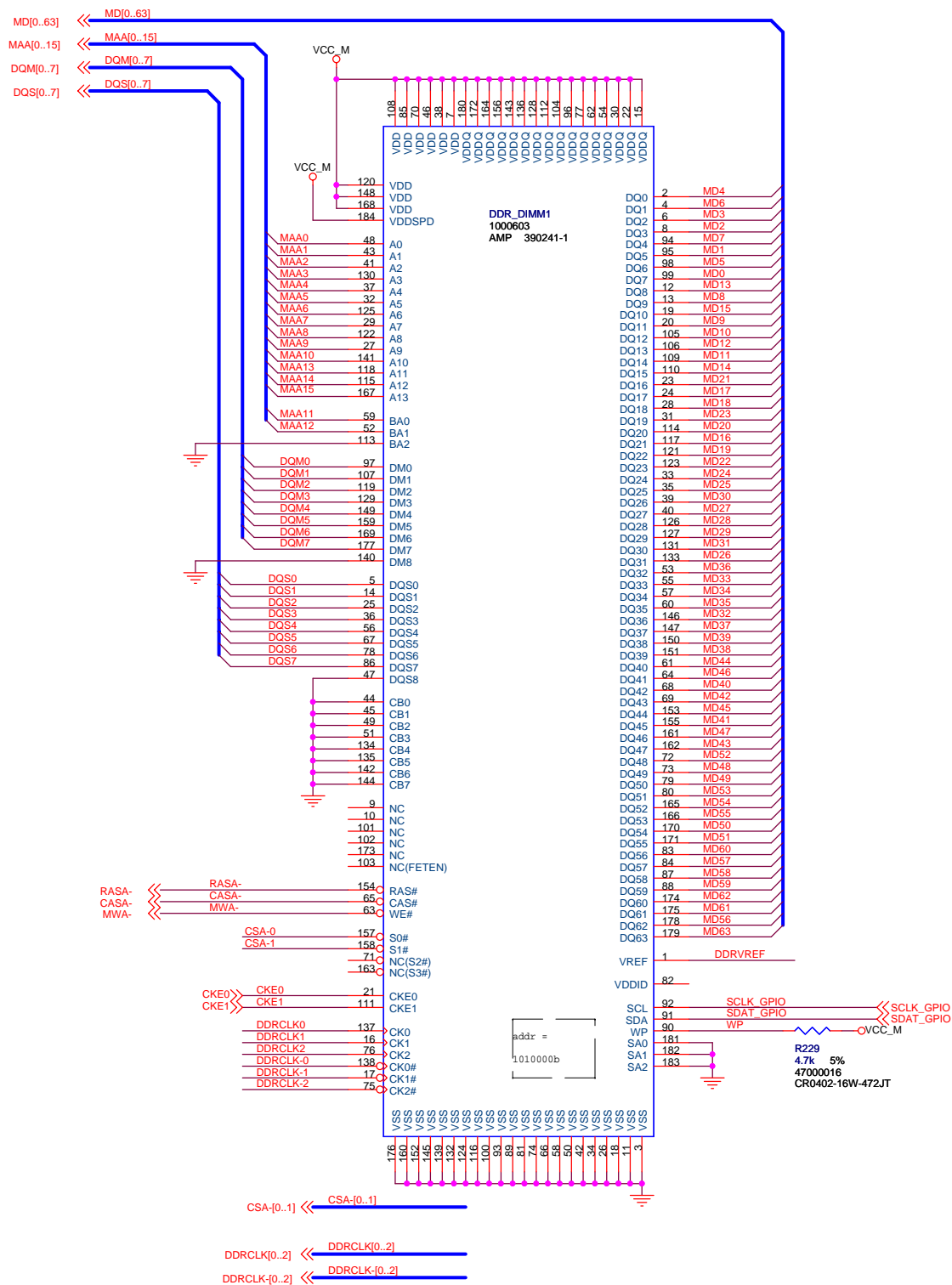

(Note: The termination resistors are only for DDR application)

SSTL-2 Termination Resistors

	DDR	Ra	Rt
MD/DQM/DQS	SSTL-2	10/0	33/47
MA/Control	SSTL-2	10/0	22/33
CS	SSTL-2	10/0	22/33
CKE	LV-CMOS/OD 2.5V		

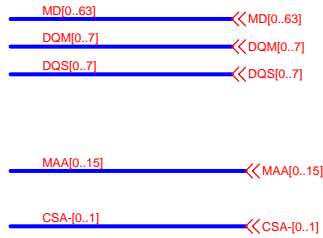
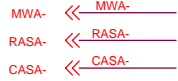

Pullup resistance can reswap by layout result.
All R-PACKS = 33 OHM 5% 1000797 EXB-28V330JX
All DISCRETE RESISTORS = 33 OHM 5% 1000769 9C04021A33R0JLHF3

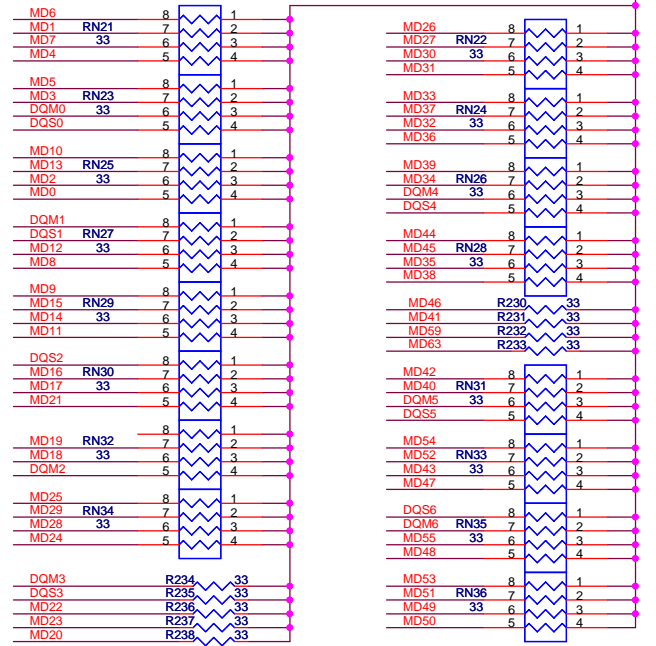

DECOUPLING CAPACITOR FOR SSTL-2 END TERMINATION VTT ISLAND
0603 Package placed within 350mils of VTT Termination R-packs

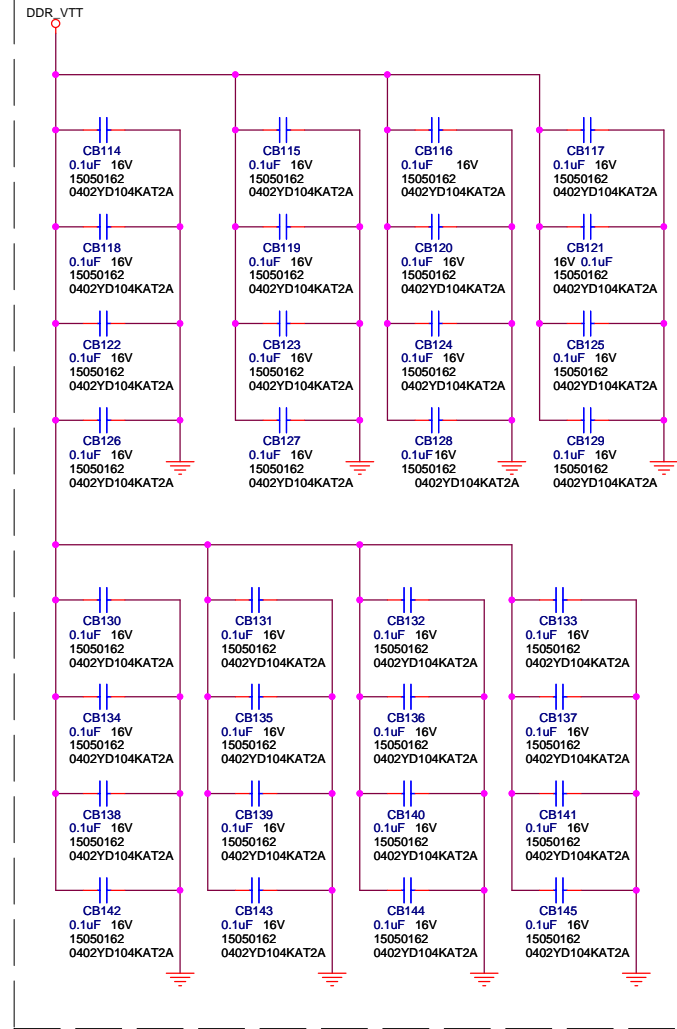

Pullup resistance can reswap by layout result.

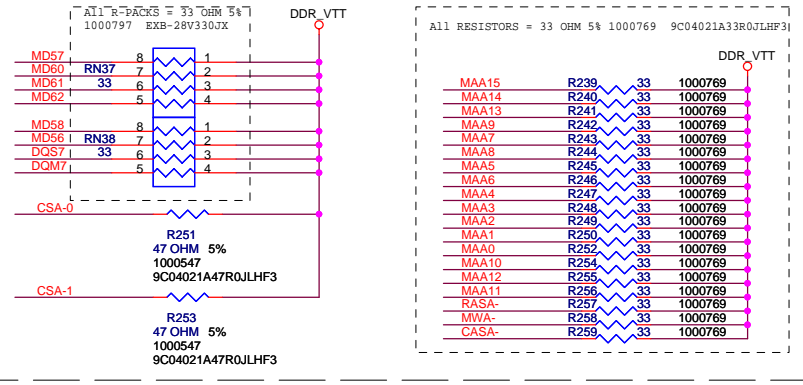

DDR_VTT

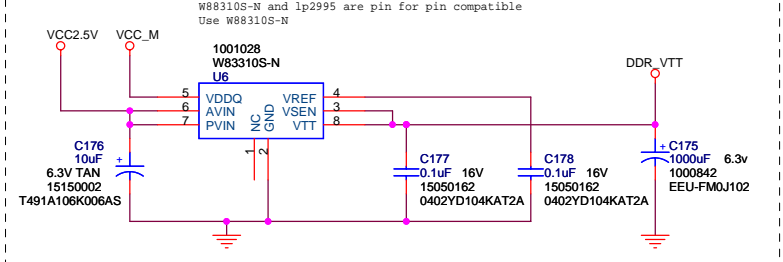

Design Create Date = Monday, December 22, 2003

		LOGIC PRODUCT DEVELOPMENT	411 WASHINGTON AVE. N MINNEAPOLIS, MN 55401 PHONE: (612) 672-9495 FAX: (612) 672-9489
Title SSTL-2 TERMINATION RESISTORS			
Size B	Number 1002124	Rev 6	
Date Friday, January 13, 2006	Project AMD Geode NX	Sheet 21 Of 43	

VGA CONNECTOR

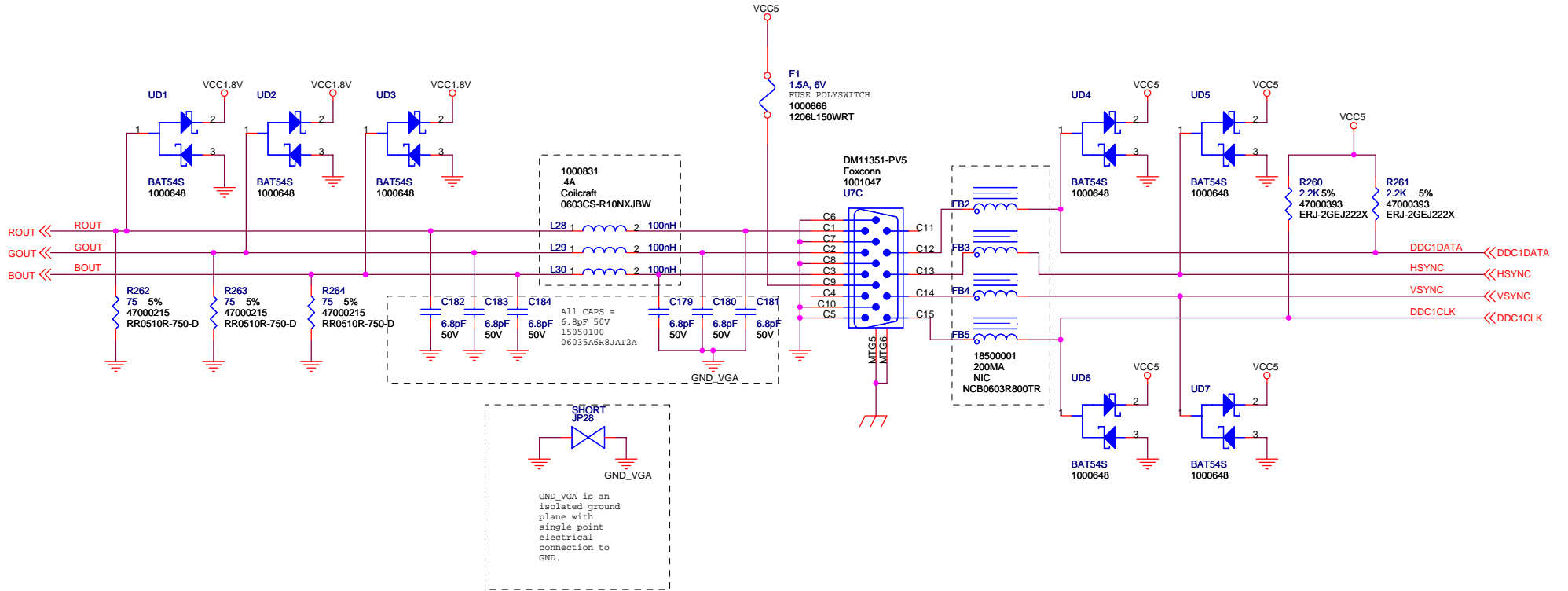

Design Create Date = Monday, December 22, 2003

		LOGIC PRODUCT DEVELOPMENT	411 WASHINGTON AVE. N MINNEAPOLIS, MN 55401 PHONE: (612) 672-9495 FAX: (612) 672-9489
--	--	--	--

Title: VGA Connector		Rev: 6
Size: Custom	Number: 1002124	
Date: Friday, January 13, 2006	Project: AMD Geode NX	Sheet 22 Of 43

IDEDA[0..15] << IDEDA[0..15]

SIS 964 SB has integrated series termination resistors and pull-up/dn resistors.

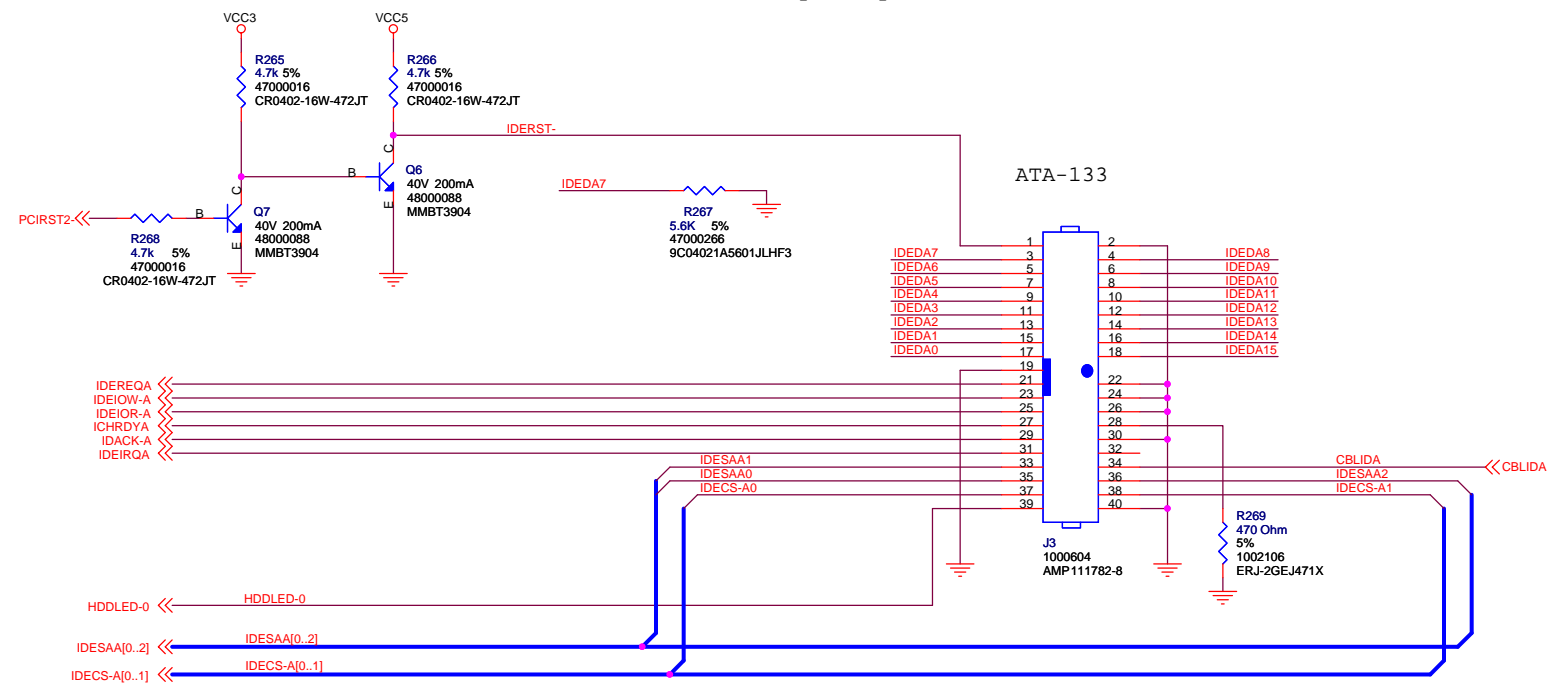

Design Create Date = Monday, December 22, 2003

				LOGIC PRODUCT DEVELOPMENT		411 WASHINGTON AVE. N MINNEAPOLIS, MN 55401 PHONE: (612) 672-9495 FAX: (612) 672-9489	
Title IDE CONNECTORS							
Size B	Number 1002124						Rev 6
Date Friday, January 13, 2006				Project AMD Geode NX		Sheet 23 Of 43	

PCI Slot

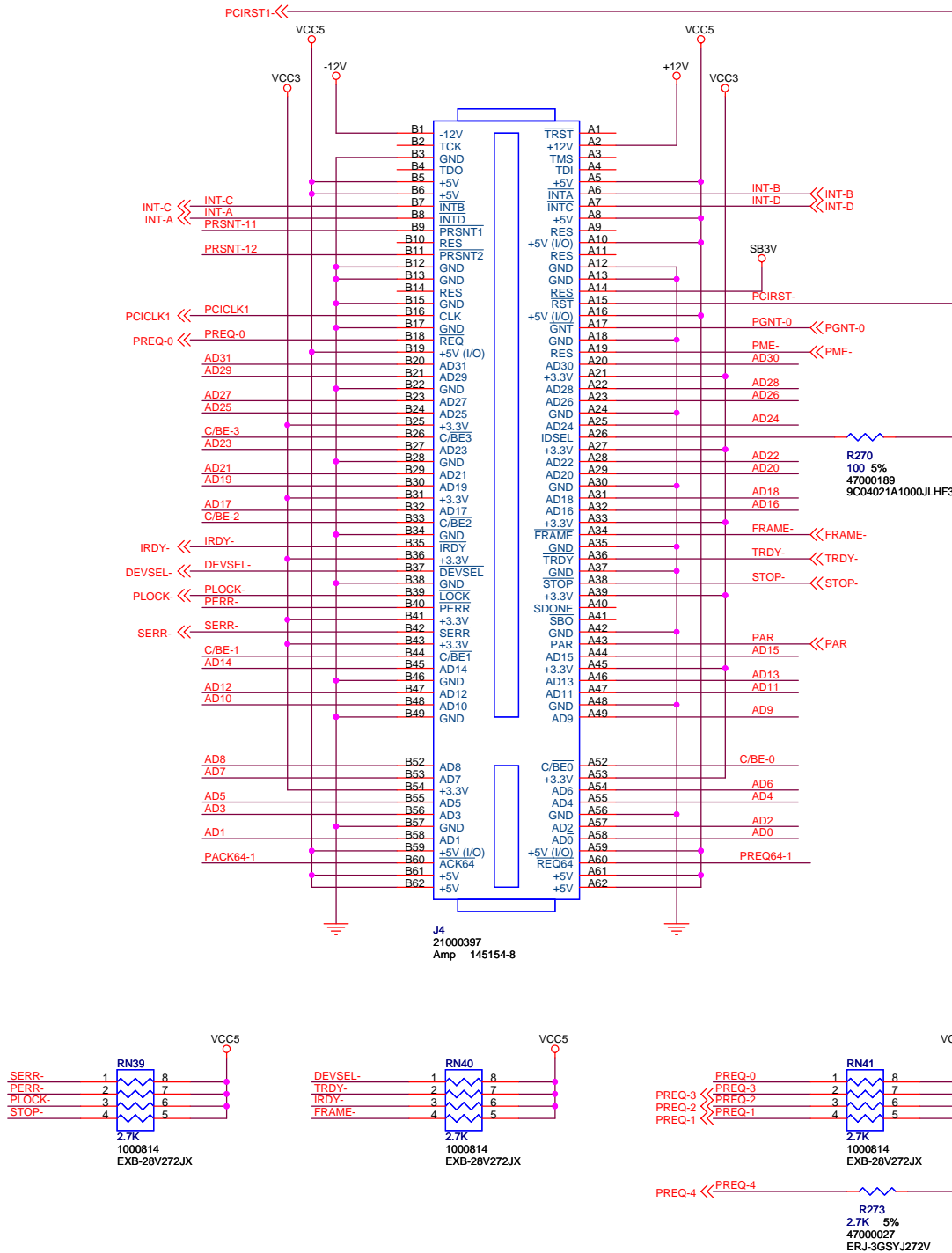

C/BE-[0..3] << C/BE-[0..3]
AD[0..31] << AD[0..31]

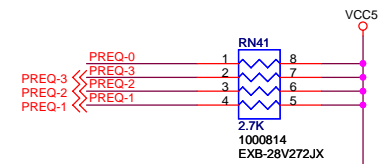
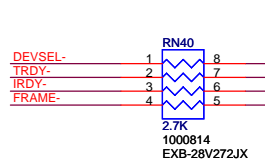
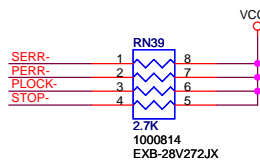
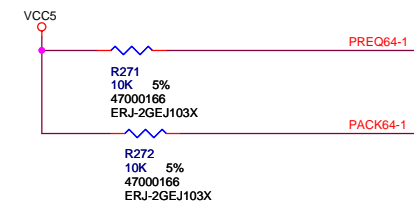
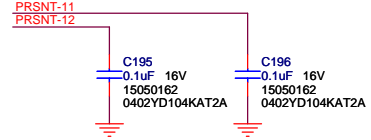
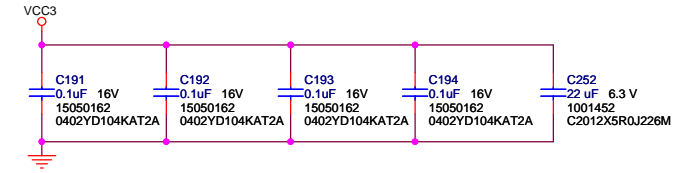
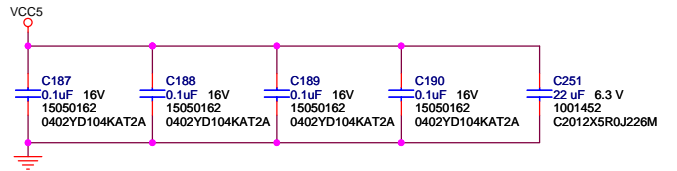
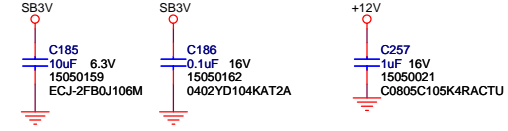

Design Create Date = Monday, December 22, 2003

		LOGIC PRODUCT DEVELOPMENT	411 WASHINGTON AVE. N MINNEAPOLIS, MN 55401 PHONE: (612) 672-9495 FAX: (612) 672-9489
Title PCI Slot 1 & 2		Number 1002124	Rev 6
Date Friday, January 13, 2006	Project AMD Geode NX	Sheet 24 Of 43	

Each USB header shares an OC circuit

SIS964 has integrated 15k pull-down resistors on USB ports

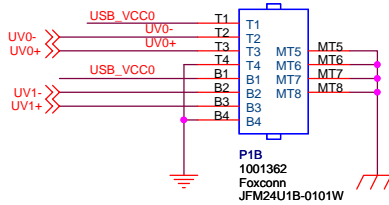

1. To avoid one of the internal controllers is too busy and the other one is idle. SIS recommends you to arrange the signals to I/O connector properly.

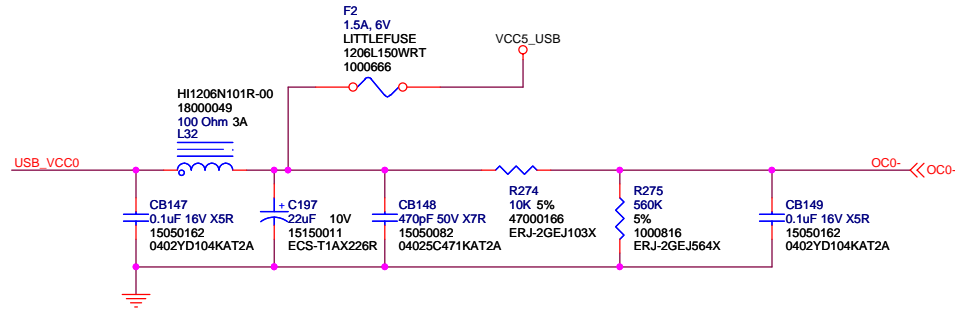
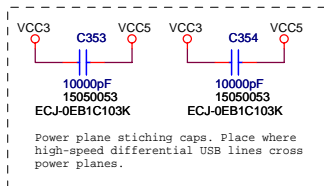
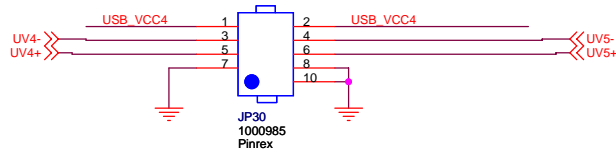
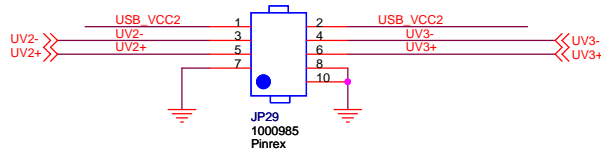

For USB VCC0, VCC2, USB bulk capacitance provided by local proximity of 1000uF cap C313 (page 37).

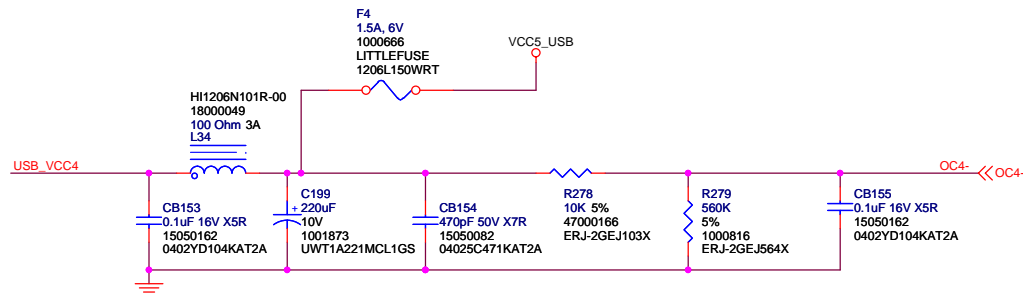
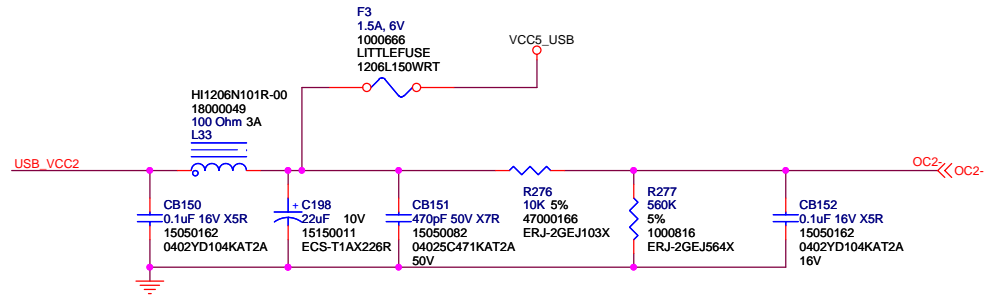

Design Create Date = Monday, December 22, 2003

		LOGIC PRODUCT DEVELOPMENT	411 WASHINGTON AVE. N MINNEAPOLIS, MN 55401 PHONE: (612) 672-9495 FAX: (612) 672-9489
Title USB CONNECTORS I			
Size Custom	Number 1002124	Rev 6	
Date Friday, January 13, 2006	Project AMD Geode NX	Sheet 25 Of 43	

RTL8201BL/CL

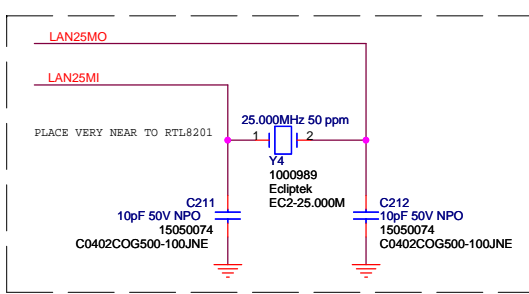
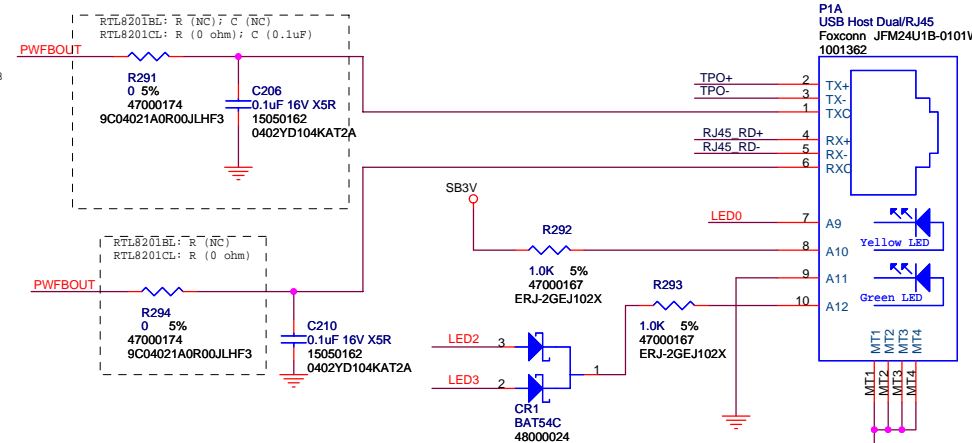
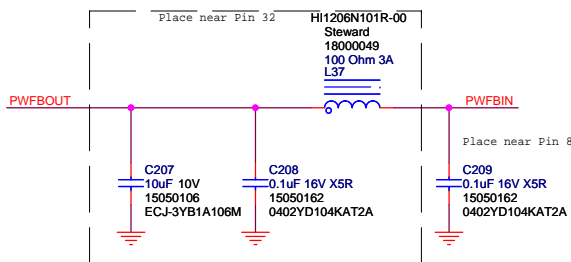
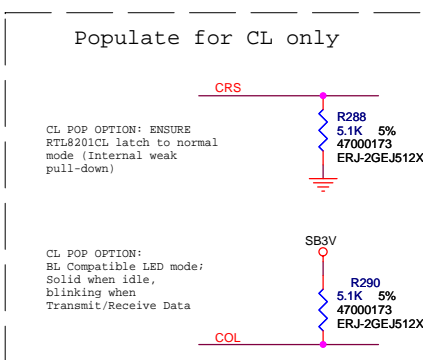
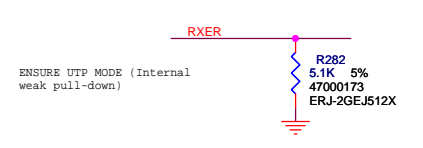
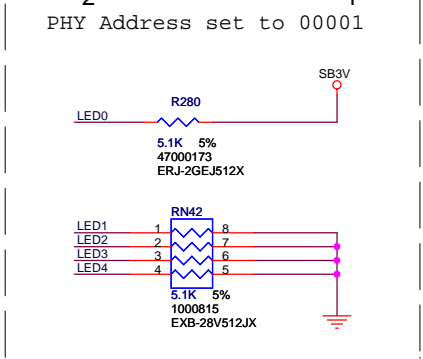
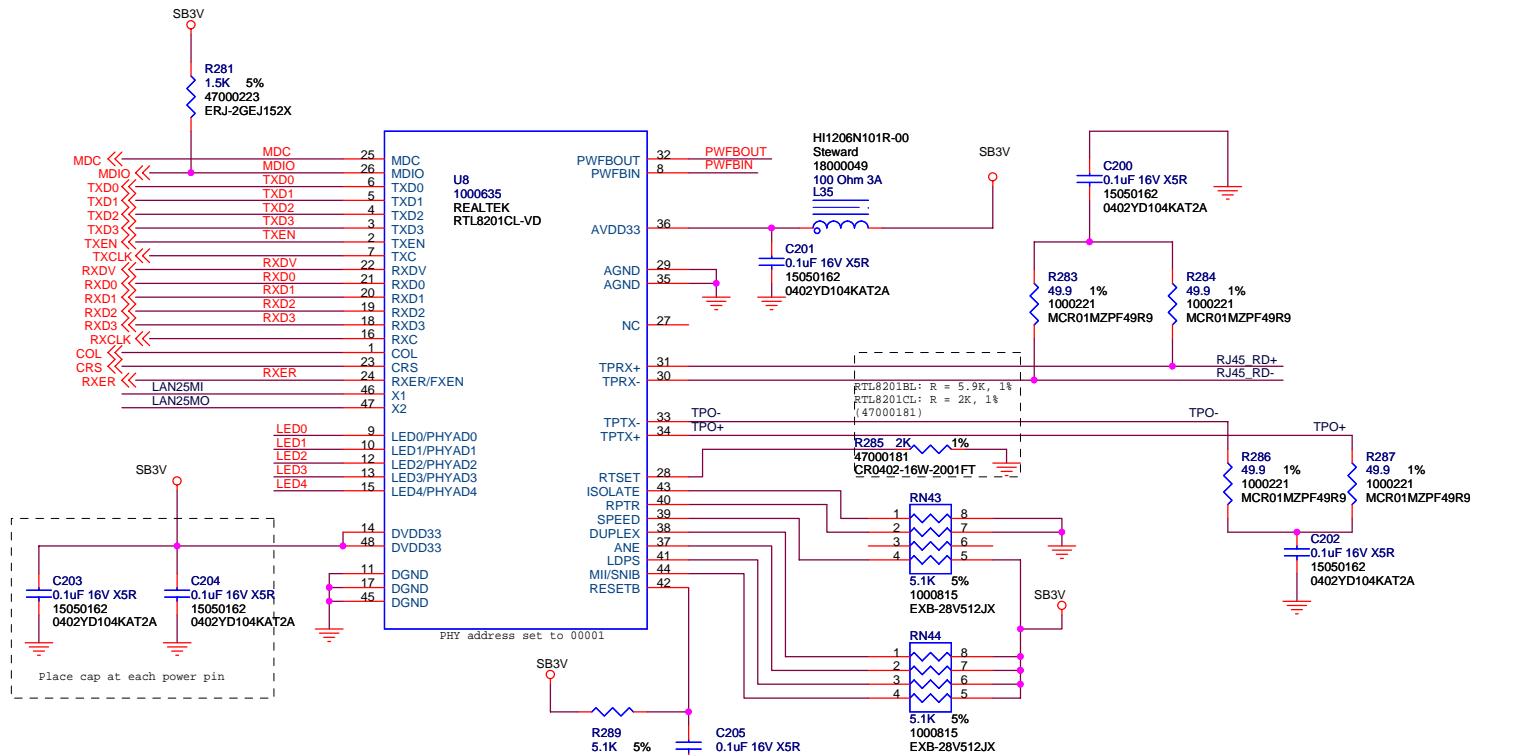

Config:

Enable: Auto negotiation, Full duplex, 100Mbps, Link Down
 Power Saving, MII interface
 Disable: Isolate, Repeater mode

RJ-45 LED SETUP:
 Top Left LED: Link LED
 Top Right LED: Activity LED

Design Create Date = Monday, December 22, 2003

		LOGIC PRODUCT DEVELOPMENT	411 WASHINGTON AVE. N MINNEAPOLIS, MN 55401 PHONE: (612) 672-9495 FAX: (612) 672-9489
Title REALTEK RTL8201BL/CL			Rev 6
Size Custom	Number 1002124	Project AMD Geode NX	
Date Friday, January 13, 2006	Project AMD Geode NX		Sheet 26 Of 43

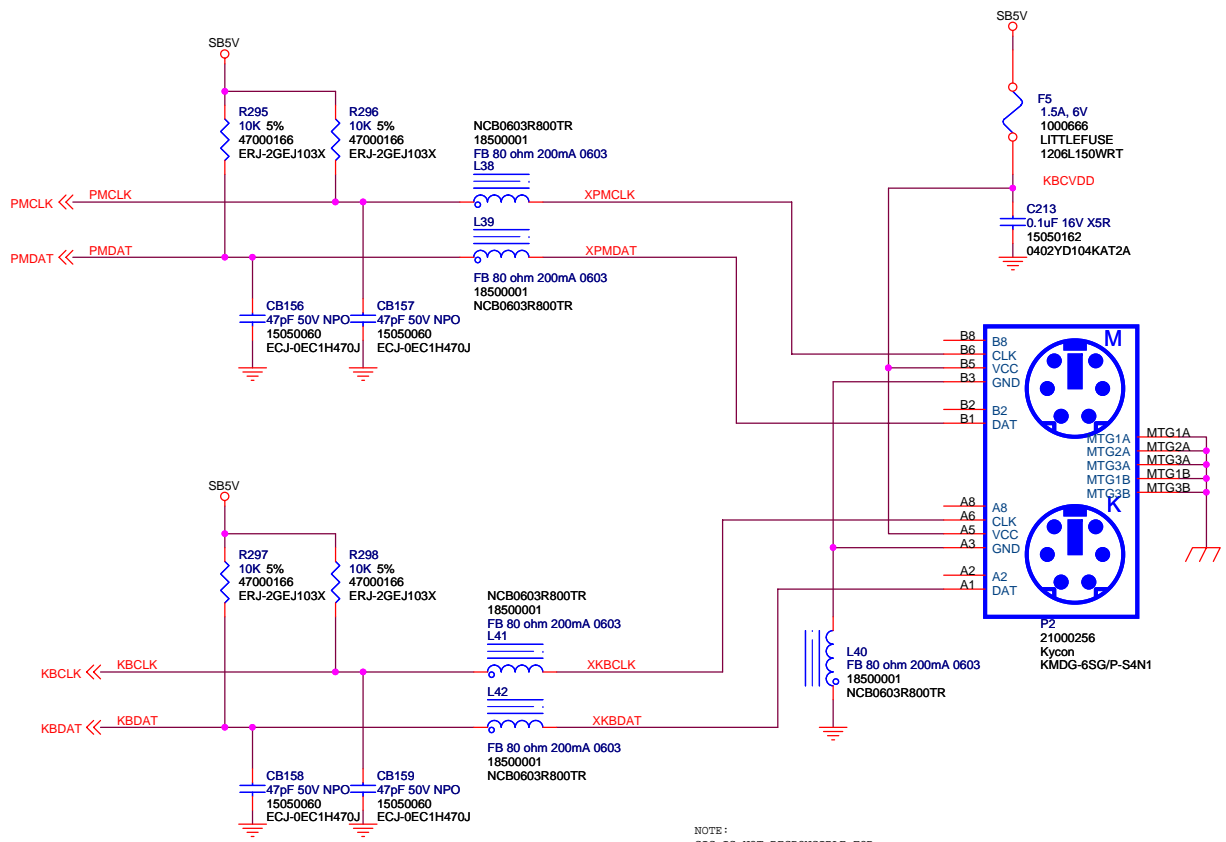

NOTE:
SIS IS NOT RESPONSIBLE FOR
ANY ERRORS OR OMISSIONS IN
THESE SCHEMATICS. THIS IS
AN EXAMPLE ONLY.

Design Create Date = Monday, December 22, 2003		411 WASHINGTON AVE. N MINNEAPOLIS, MN 55401 PHONE: (612) 672-9495 FAX: (612) 672-9489	
		LOGIC PRODUCT DEVELOPMENT	
Title KEYBOARD & MOUSE CONNECTORS			
Size B	Number 1002124	Rev 6	
Date Friday, January 13, 2006	Project AMD Geode NX	Sheet 27 Of 43	

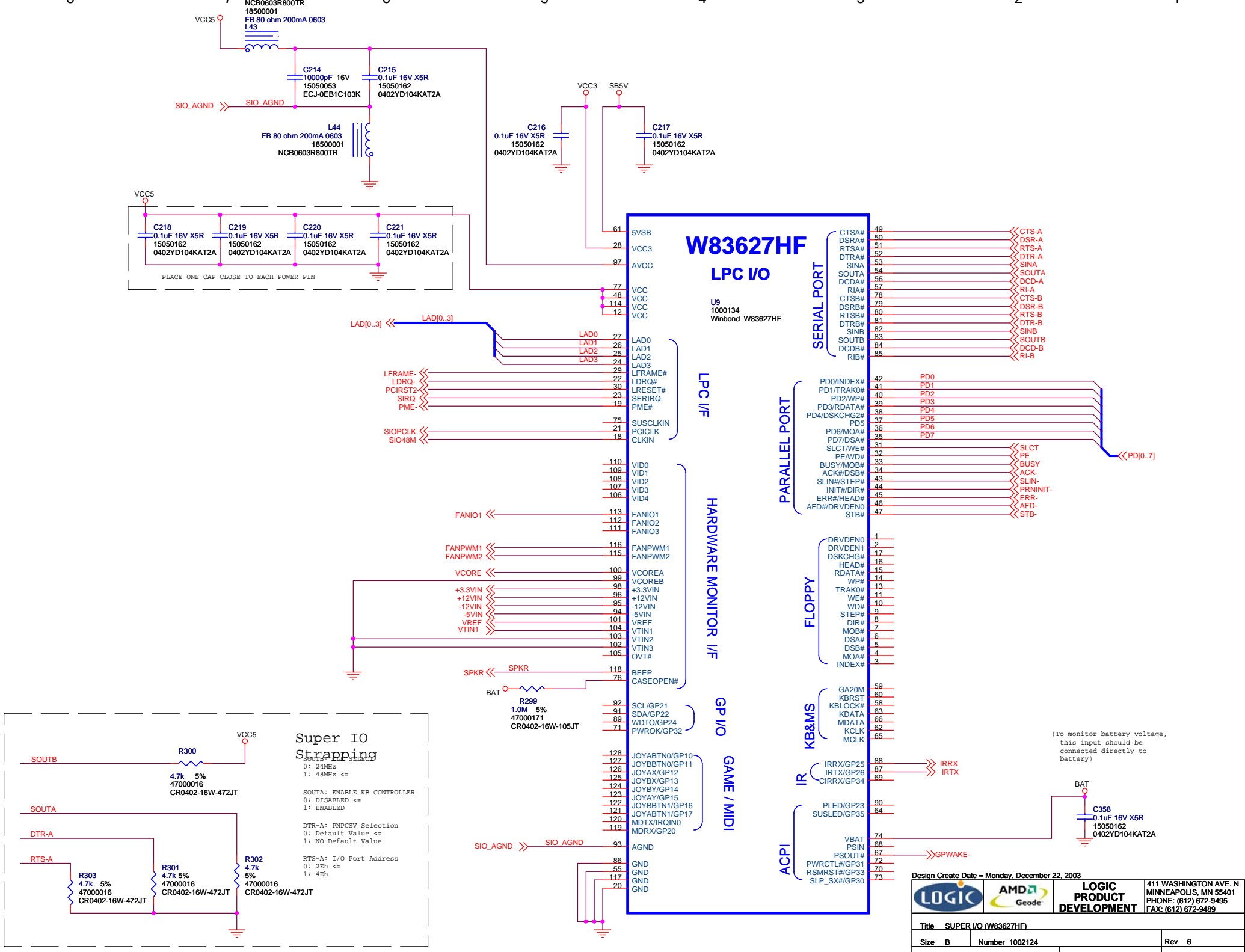

(To monitor battery voltage, this input should be connected directly to battery)

Design Create Date = Monday, December 22, 2003

		LOGIC PRODUCT DEVELOPMENT	411 WASHINGTON AVE. N MINNEAPOLIS, MN 55401 PHONE: (612) 672-9495 FAX: (612) 672-9489
Title SUPER I/O (W83627HF)			
Size B	Number 1002124	Project AMD Geode NX	Rev 6
Date Friday, January 13, 2006	Sheet 28 Of 43		

COM PORTS

COM1

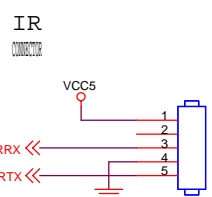
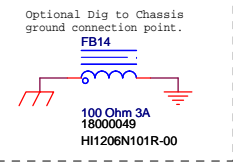
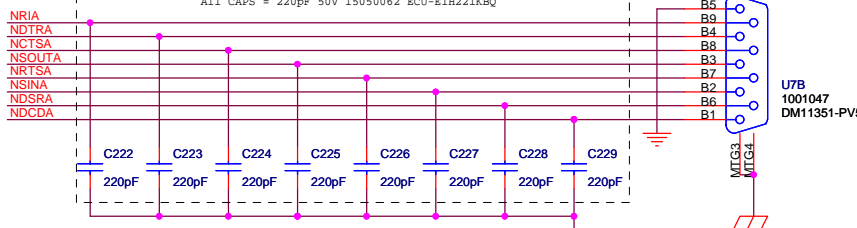
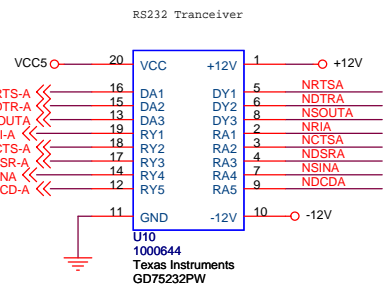

JP31
21000226
Samtec
TSW-105-23-T-S

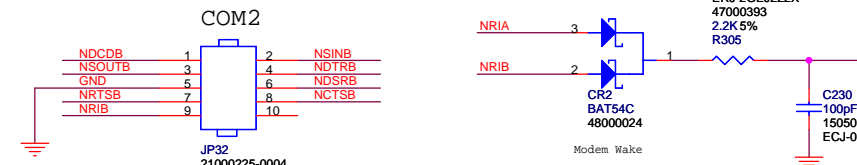
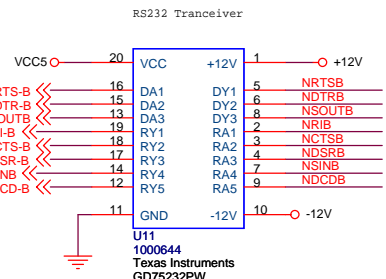

PRT PORT

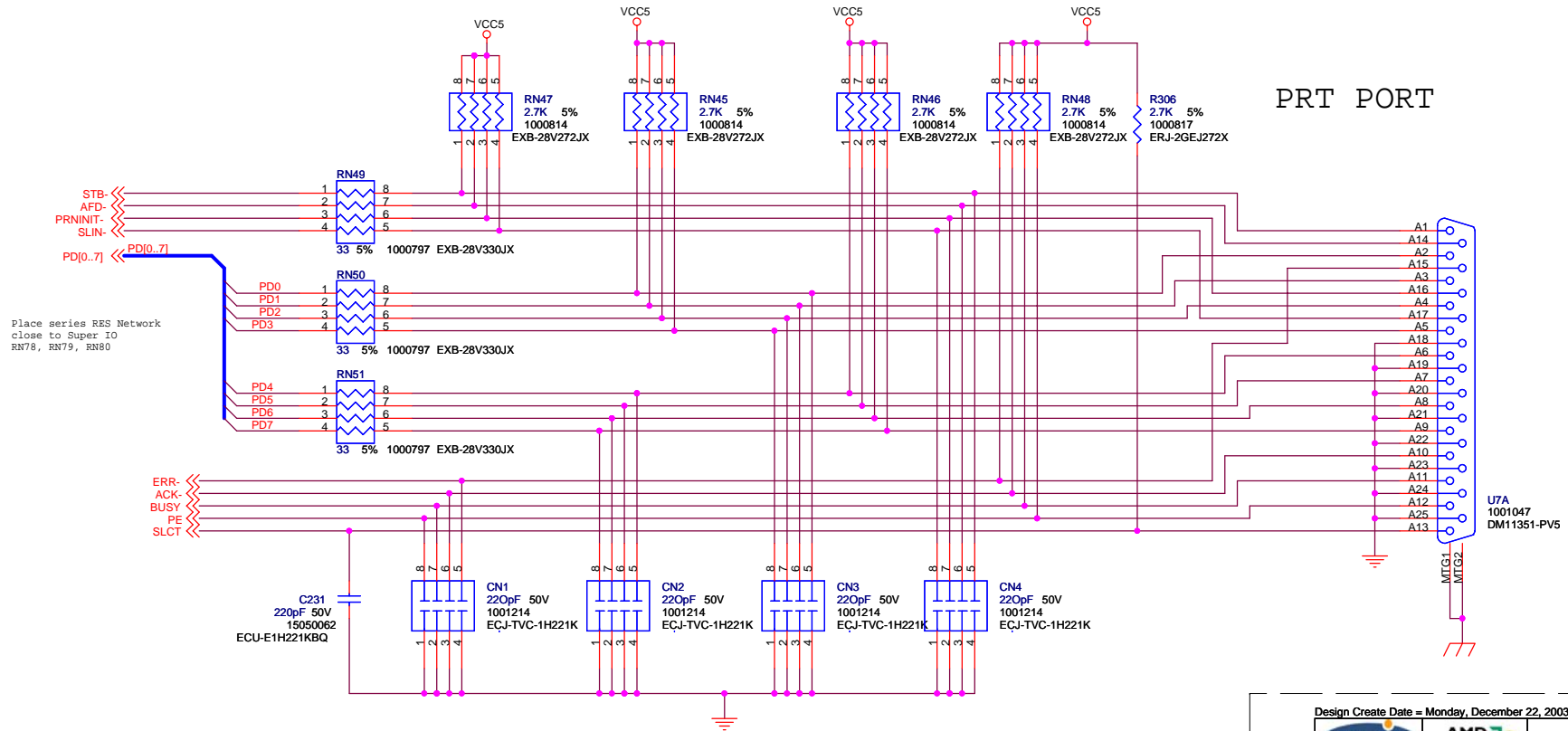

Design Create Date = Monday, December 22, 2003

		LOGIC PRODUCT DEVELOPMENT	411 WASHINGTON AVE. N MINNEAPOLIS, MN 55401 PHONE: (612) 672-9495 FAX: (612) 672-9489
Title COM & IR & LPT PORT (FOR W83627HF)			
Size B	Number 1002124	Rev 6	
Date Friday, January 13, 2006	Project AMD Geode NX	Sheet 29 Of 43	

Hardware Monitor circuits

Voltage Sensing

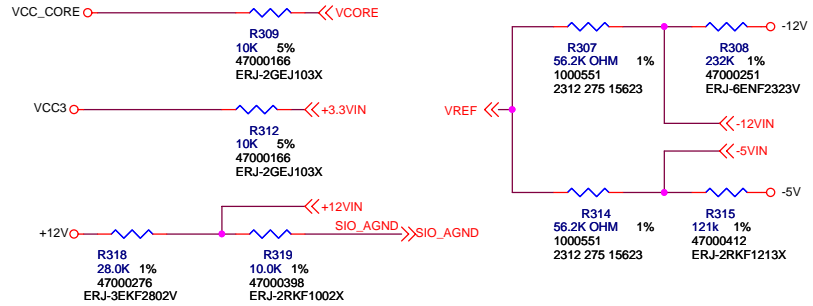

PWM Circuit for FAN speed control

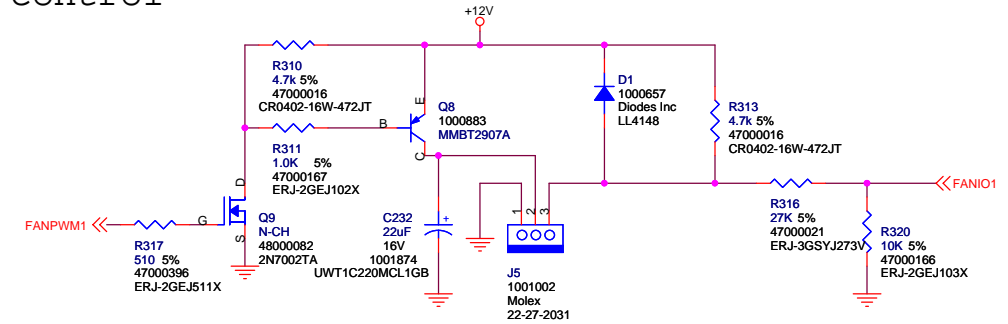

ATX Power Supply Shut-Off Circuit

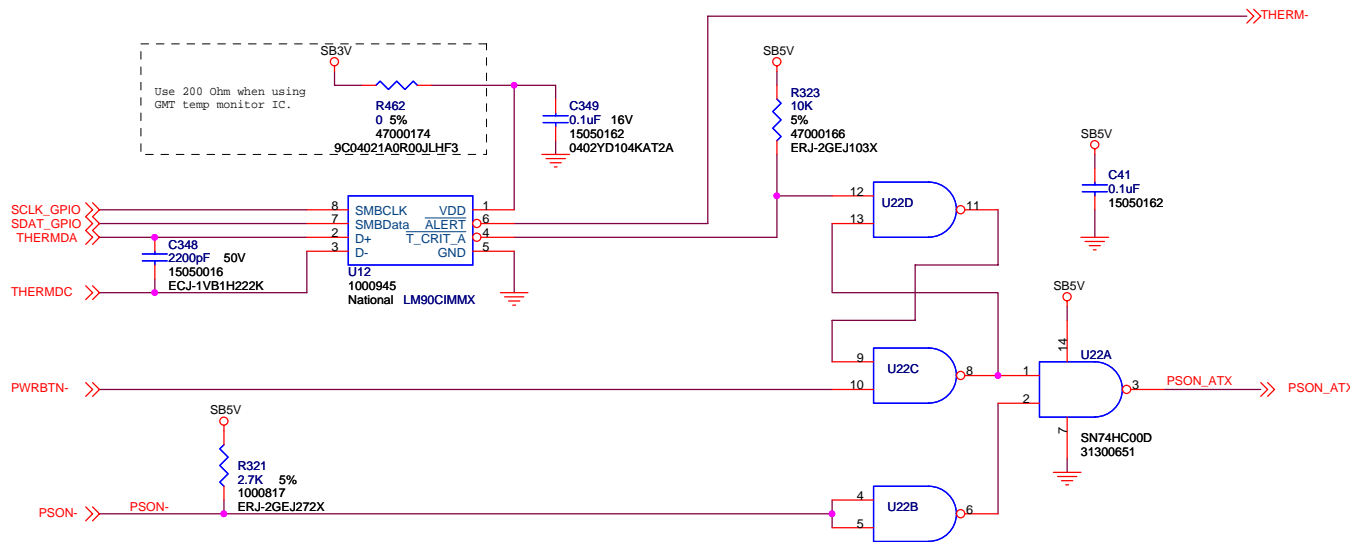

System Temp Monitor

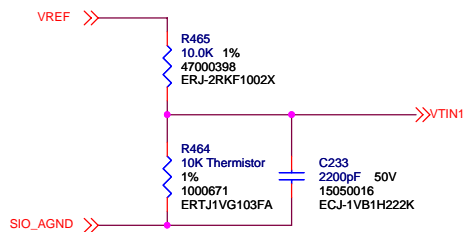

Design Create Date = Monday, December 22, 2003

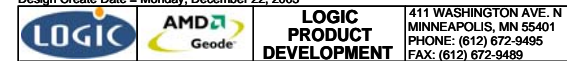

411 WASHINGTON AVE. N
MINNEAPOLIS, MN 55401
PHONE: (612) 672-9495
FAX: (612) 672-9489

Title HARDWARE MONITOR (W83627HF)		
Size B	Number 1002124	Rev 6
Date Friday, January 13, 2006	Project AMD Geode NX	Sheet 30 Of 43

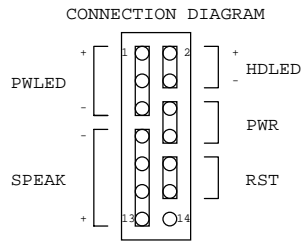
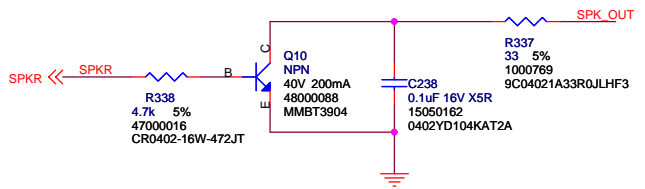
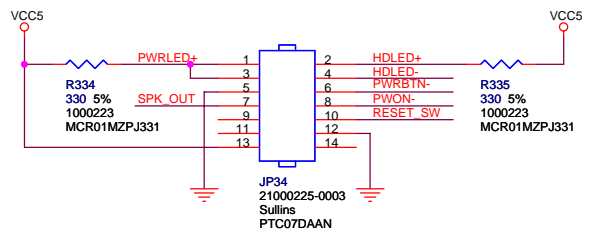
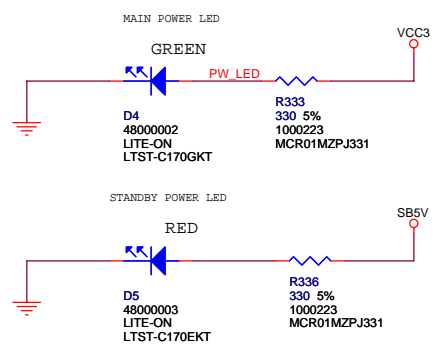
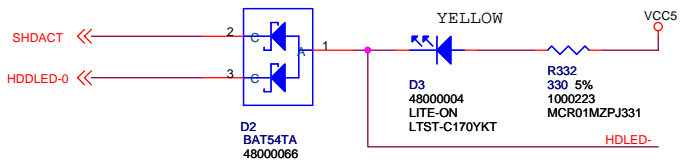
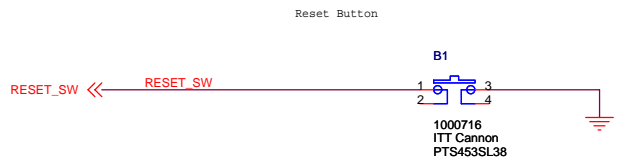
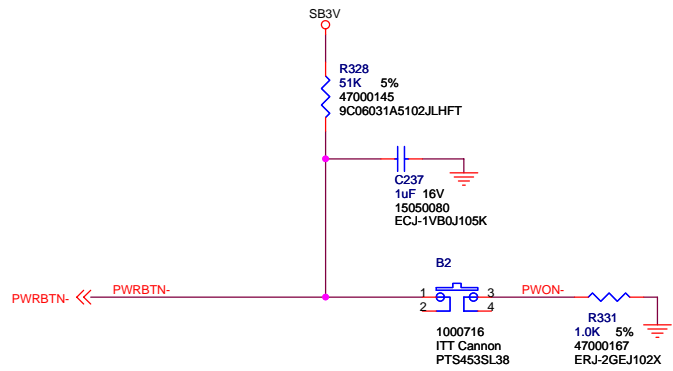

Design Create Date = Monday, December 22, 2003

				LOGIC PRODUCT DEVELOPMENT		411 WASHINGTON AVE. N MINNEAPOLIS, MN 55401 PHONE: (612) 672-9495 FAX: (612) 672-9489	
Title Switches & LEDs							
Size B	Number 1002124						Rev 6
Date Friday, January 13, 2006				Project AMD Geode NX		Sheet 31 Of 43	

15 - AUDIO

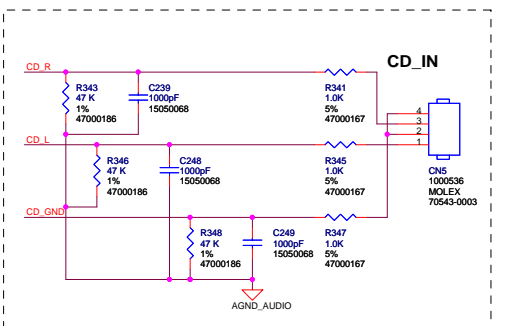
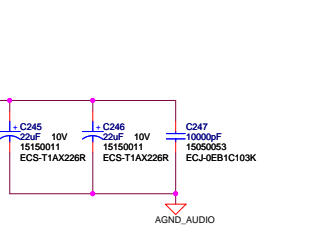
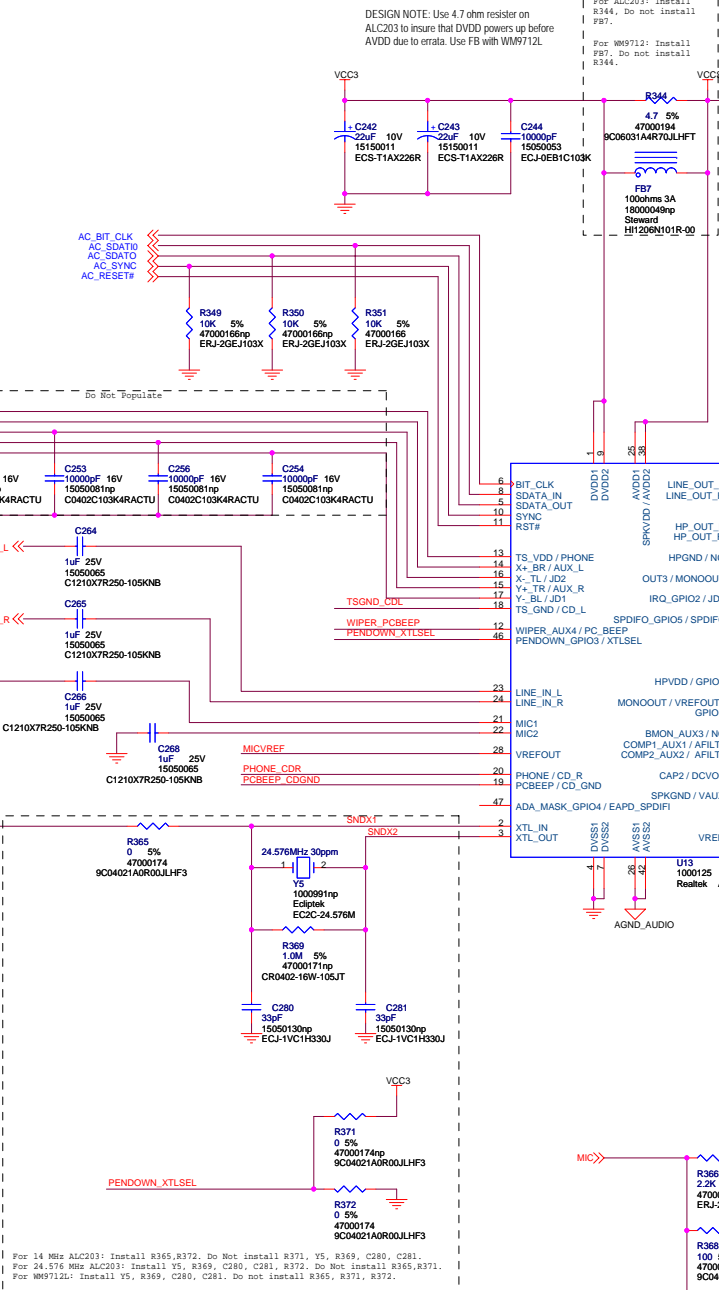
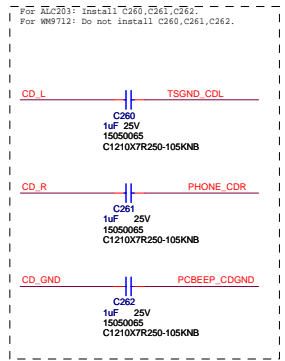
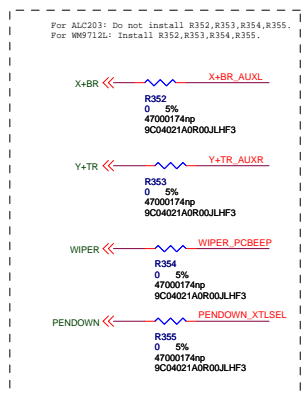
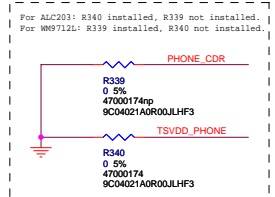
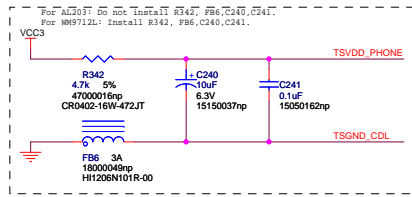

For ALC203: Install all components.
For WM9712L: CD-IN not supported. Do not install components.

app note for wolfson uses different values here, 8.2k and 10ks with a 1uF in series

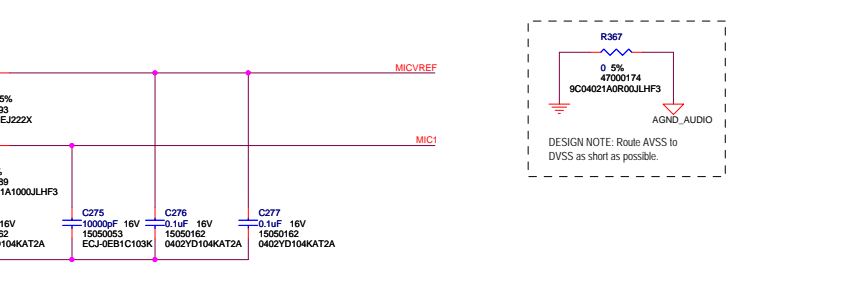
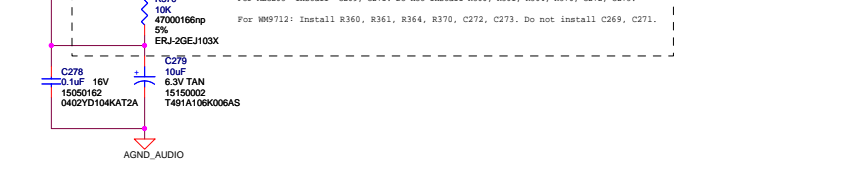
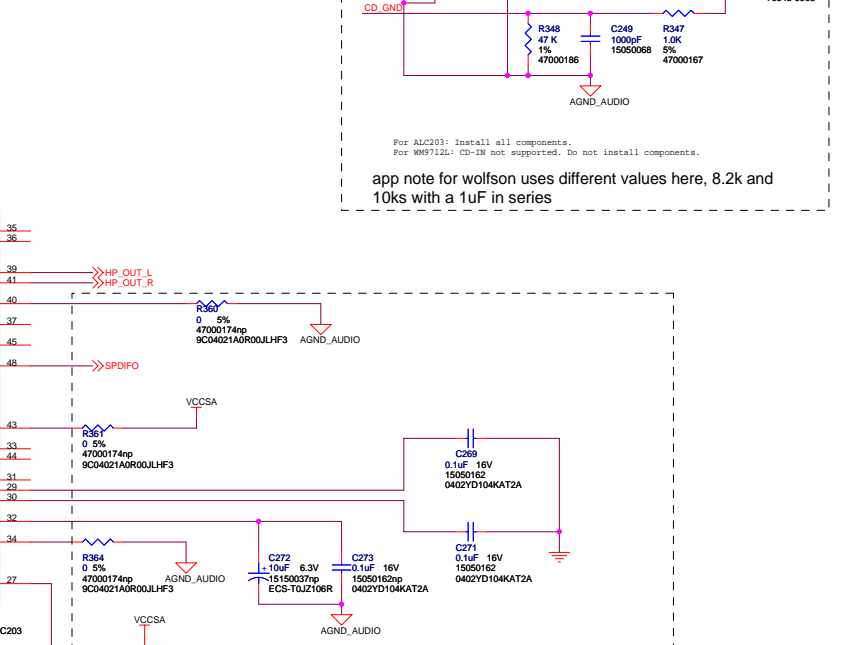

For 14 MHz ALC203: Install R365, R372. Do not install R371, Y5, R369, C280, C281.
For 24.576 MHz ALC203: Install Y5, R369, C280, C281, R372. Do not install R365, R371.
For WM9712L: Install Y5, R369, C280, C281. Do not install R365, R371, R372.

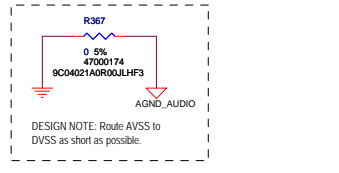

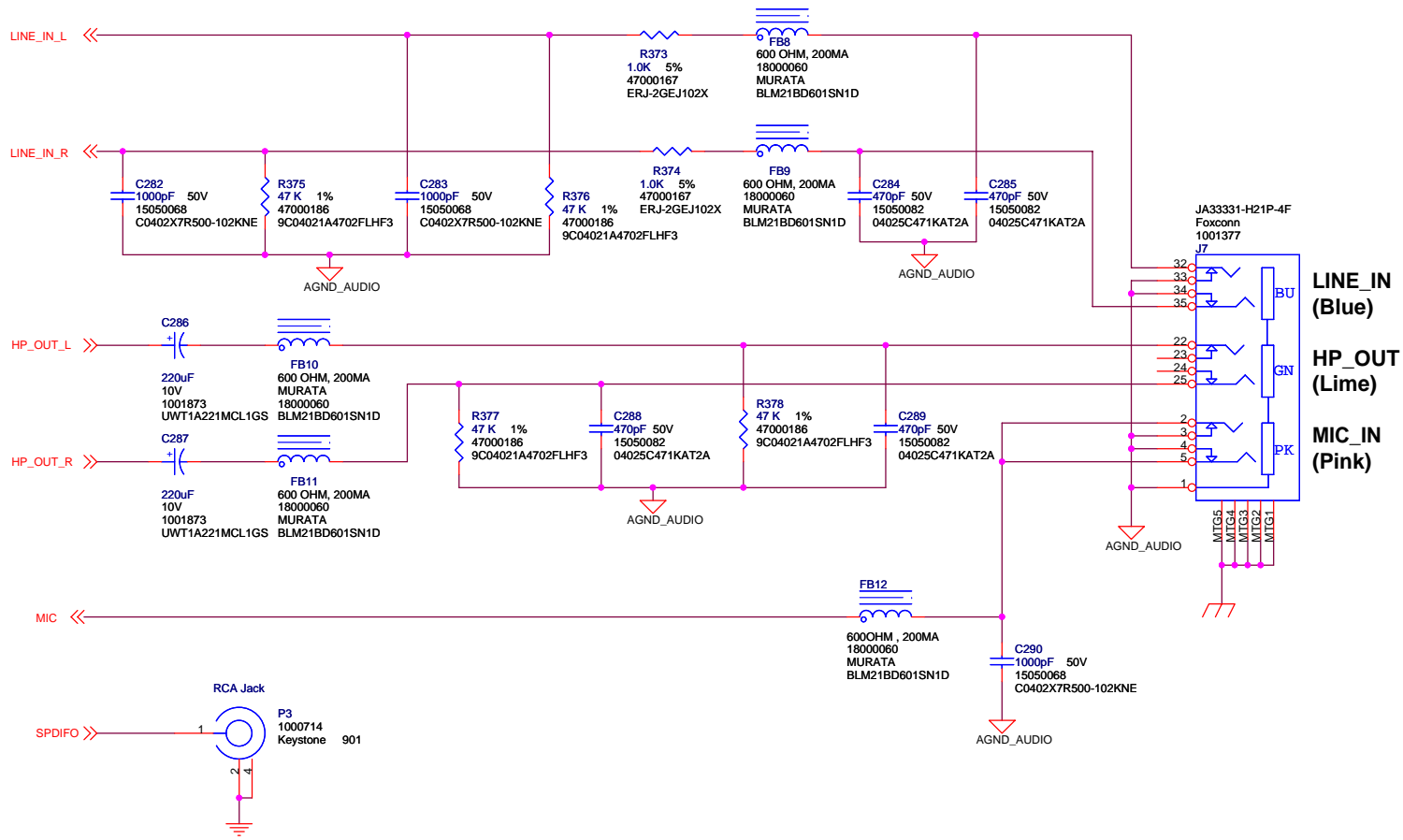

Design Create Date = Monday, December 22, 2003

		LOGIC PRODUCT DEVELOPMENT	411 WASHINGTON AVE. N MINNEAPOLIS, MN 55401 PHONE: (612) 672-9495 FAX: (612) 672-9489
Title Audio Input/Output			
Size B	Number 1002124	Rev 6	
Date Friday, January 13, 2006	Project AMD Geode NX	Sheet 33 Of 43	

LPC ROM

** PLCC 32 SOCKET **
 (For SST49LF004B
 (4Mbit))

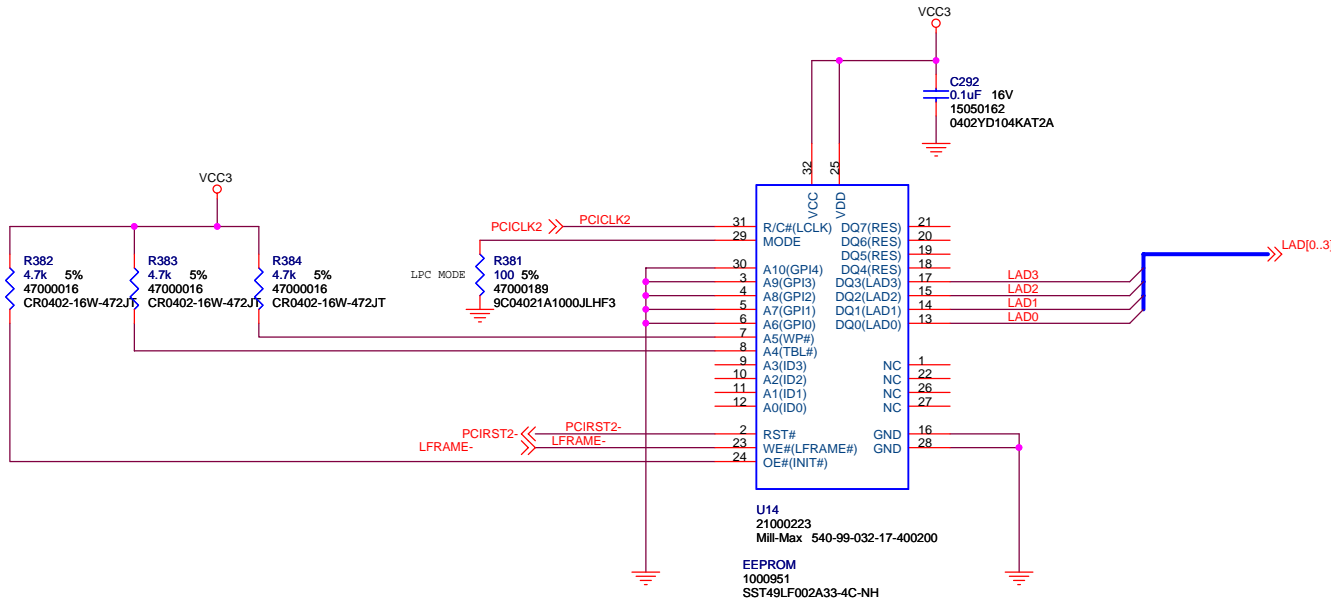

-ID[3:0] internally pulled down
 need boot device ID = 0000

-Unused GPIOs must NOT be floated. Need to be pulled up??

-TBL#:
 0: prevents programming to boot block sector
 1: disable write protection to top block sector
 DO WE WANT WRITE PROTECTION?

-WP#:
 0: prevents programming all but top block sector
 1: disable write protection
 DO WE WANT WRITE PROTECTION?

-INIT#: Second reset for in system use.
 Functions identically to RST#

Design Create Date = Monday, December 22, 2003

		LOGIC PRODUCT DEVELOPMENT	411 WASHINGTON AVE. N MINNEAPOLIS, MN 55401 PHONE: (612) 672-9495 FAX: (612) 672-9489
--	--	--	--

Title ROM		Rev 6	
Size B	Number 1002124	Project AMD Geode NX	Sheet 34 Of 43
Date Friday, January 13, 2006			

RTC

NOTE!

- 1.The RTCVDD is 3V
 - 2.Decoupling capacitor must be close to 96x RTCVDD pin.
 - 3.RTC circuit must strictly follow SiS's recommended design
- SiS is not responsible for RTC problems from foreign designs.

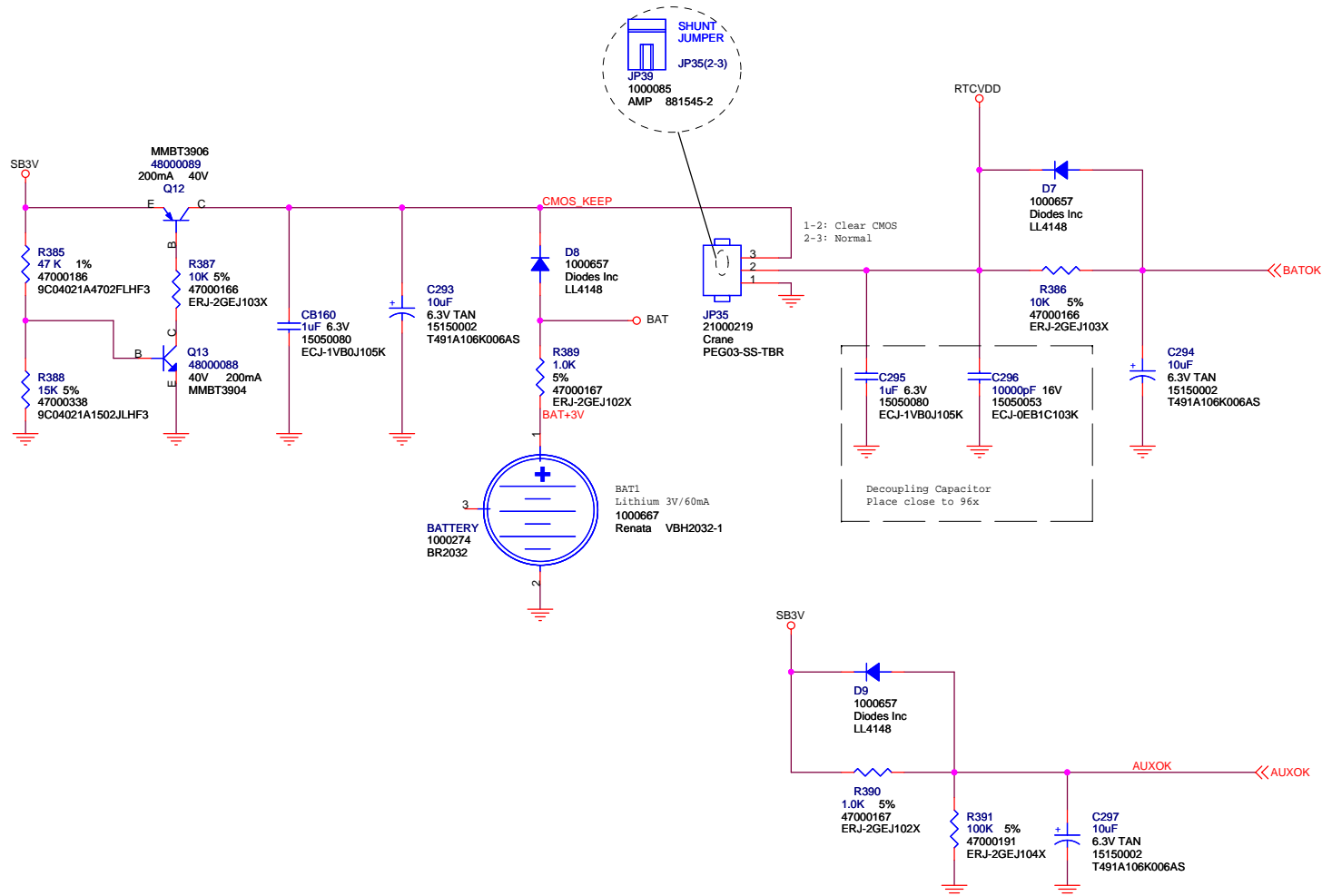

Design Create Date = Monday, December 22, 2003

		LOGIC PRODUCT DEVELOPMENT	411 WASHINGTON AVE. N MINNEAPOLIS, MN 55401 PHONE: (612) 672-9495 FAX: (612) 672-9489
--	--	----------------------------------	--

Title RTC			
Size B	Number 1002124	Rev 6	
Date Friday, January 13, 2006	Project AMD Geode NX	Sheet 35 Of 43	

IVDD (For 741GX)

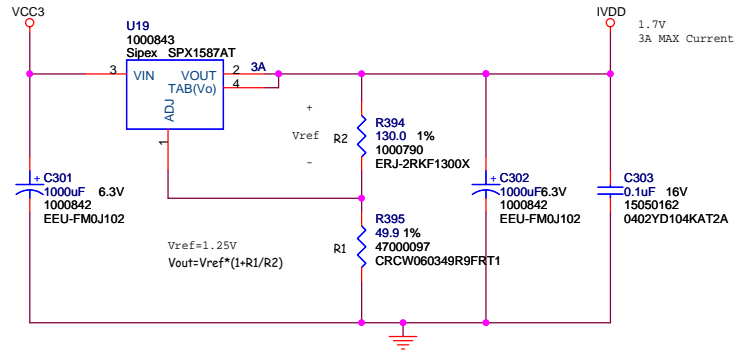

SB3.3V

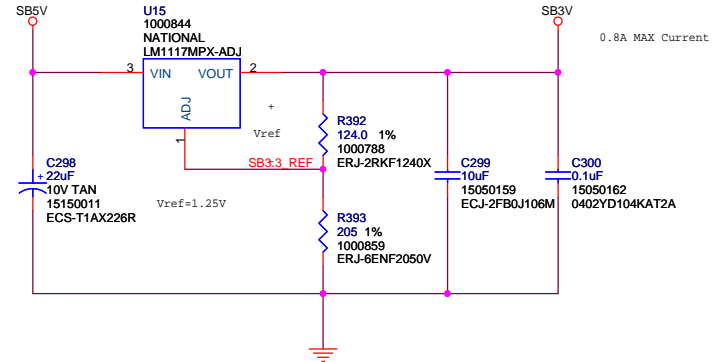

SB1.8V

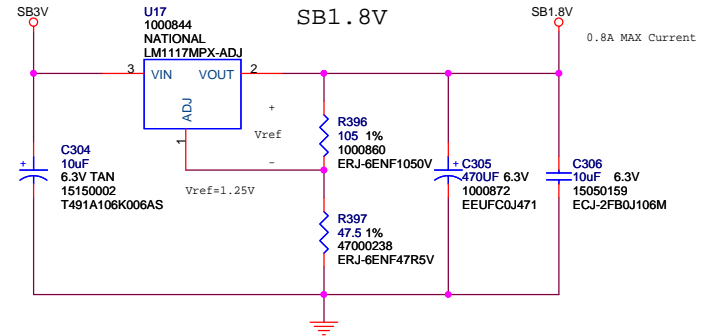

VCC1.8V (For 96x)

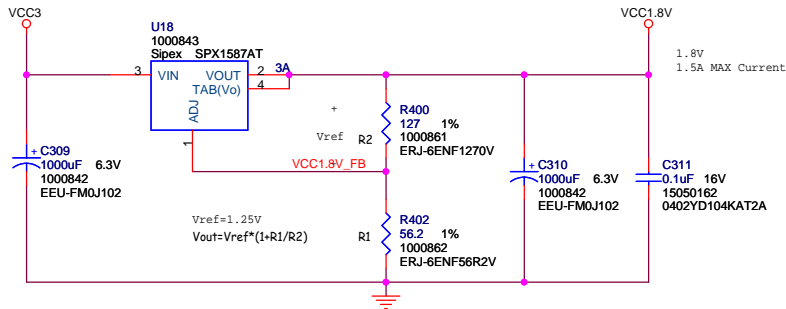

AUX_IVDD (For 741GX)

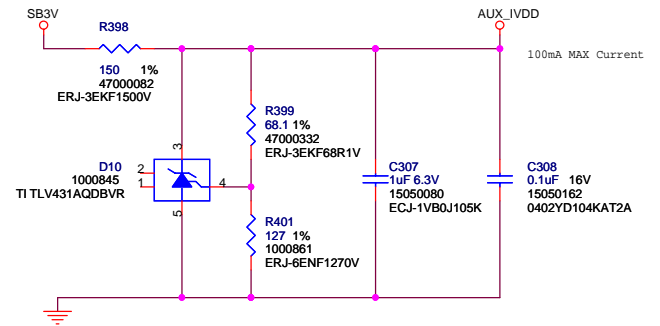

Design Create Date = Monday, December 22, 2003

		LOGIC PRODUCT DEVELOPMENT	411 WASHINGTON AVE. N MINNEAPOLIS, MN 55401 PHONE: (612) 672-9495 FAX: (612) 672-9489
Title VCC1.8V, SB1.8V, SB3V, VDDQ, IVDD, AUX_IVDD			
Size B	Number 1002124	Rev 6	
Date Friday, January 13, 2006	Project AMD Geode NX	Sheet 36 Of 43	

VCC5_USB

AUTO VOLTAGE SWITCH FOR ACPI STATE 3

1. IN S0,S1
THIS CIRCUIT PASSES THE NORMAL POWER
2. IN S3,S4,S5
THIS CIRCUIT PASSES THE STANDBY POWER

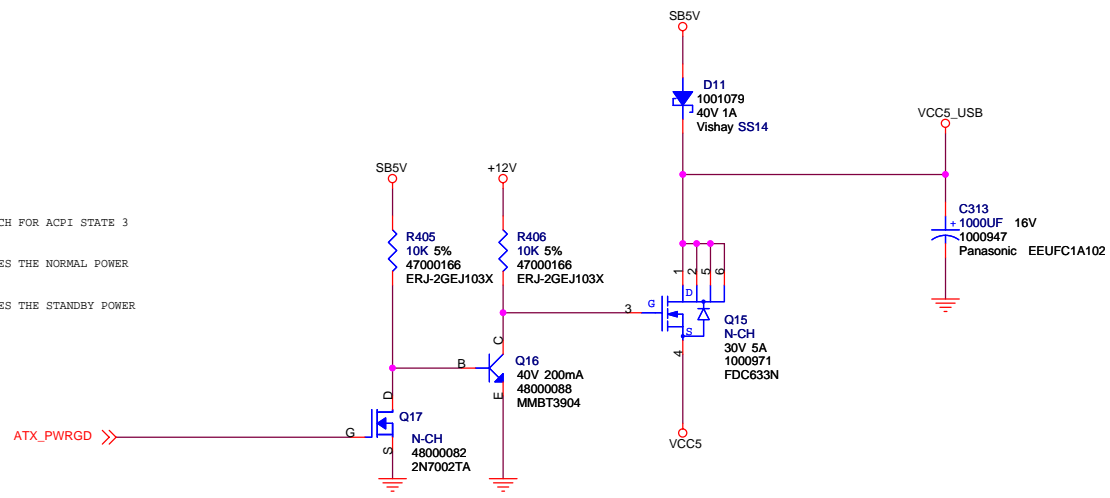

Design Create Date = Monday, December 22, 2003

		LOGIC PRODUCT DEVELOPMENT	411 WASHINGTON AVE. N MINNEAPOLIS, MN 55401 PHONE: (612) 672-9495 FAX: (612) 672-9489
--	--	----------------------------------	--

Title VCC3 DUAL & VCC5 DUAL & VCC1.8 DUAL			
Size B	Number 1002124	Rev 6	
Date Friday, January 13, 2006	Project AMD Geode NX	Sheet 37 Of 43	

DDR SDRAM POWERs

VCC2.5 Main SDRAM power

The FET is a TO263 and needs to have a minimum 1 sq. inch copper pour behind it to dissipate the potential 2-3 Watts across the FET.

Use part number 1001173 (137) for R408 for 2.55V output

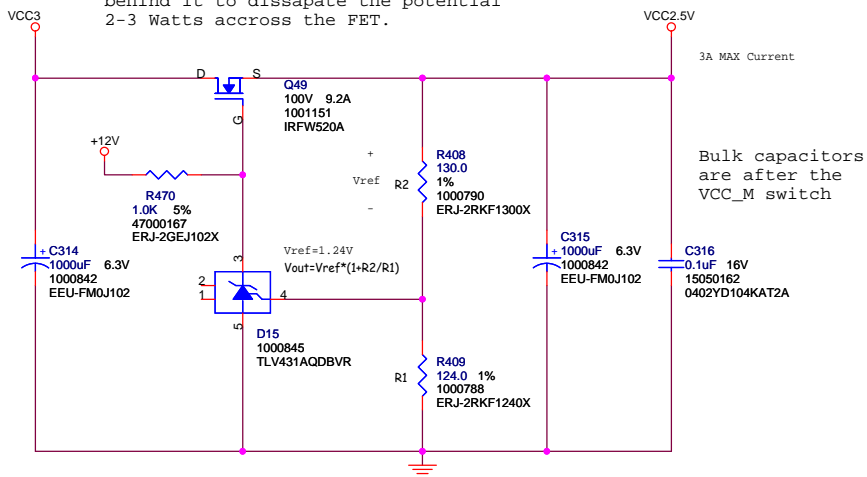

SB2.5V

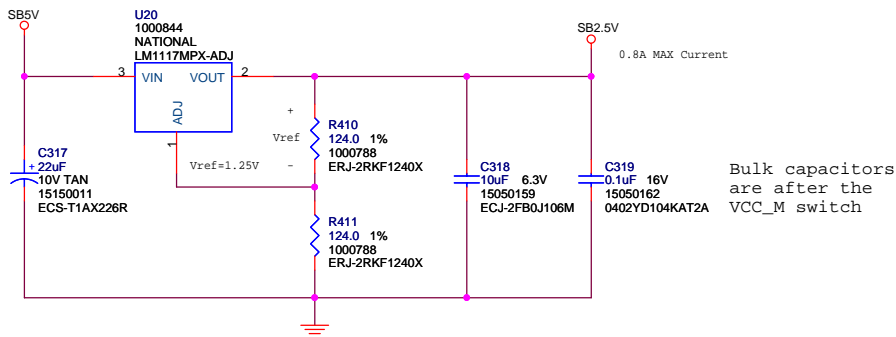

Design Create Date = Monday, December 22, 2003

		LOGIC PRODUCT DEVELOPMENT	411 WASHINGTON AVE. N MINNEAPOLIS, MN 55401 PHONE: (612) 672-9495 FAX: (612) 672-9489
Title VCC_M & SB_M & DDR_VTT (DDR)			
Size B	Number 1002124	Rev 6	
Date Friday, January 13, 2006	Project AMD Geode NX	Sheet 38 Of 43	

VCC_DIMM

VCC_M and SB2.5V Standby VOLTAGE SWITCH
 WHEN IN
 S0,S1
 THIS CIRCUIT PASSES THE NORMAL POWER
 WHEN IN S3
 THIS CIRCUIT PASSES THE STANDBY POWER

Place near DIMM slot.
S3AUXSW- >>

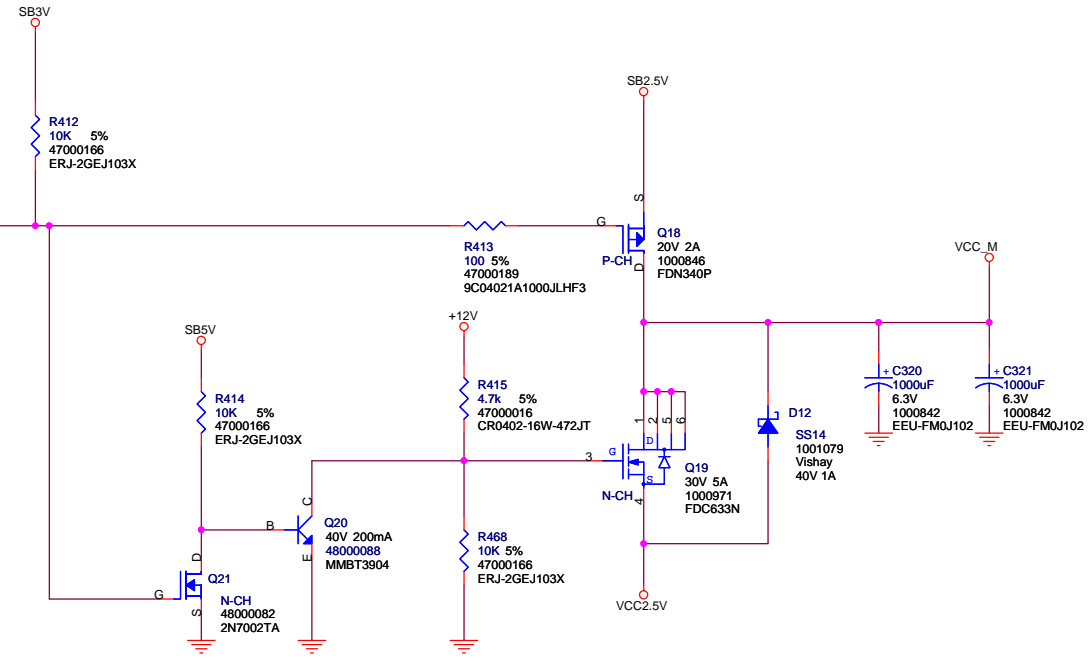

Design Create Date = Monday, December 22, 2003

		LOGIC PRODUCT DEVELOPMENT	411 WASHINGTON AVE. N MINNEAPOLIS, MN 55401 PHONE: (612) 672-9495 FAX: (612) 672-9489
--	--	----------------------------------	--

Title DDR/MIXED SDRAM VCC_DIMM			
Size B	Number 1002124	Rev 6	
Date Friday, January 13, 2006	Project AMD Geode NX	Sheet 39 Of 43	

25W CPU VCORE Supply

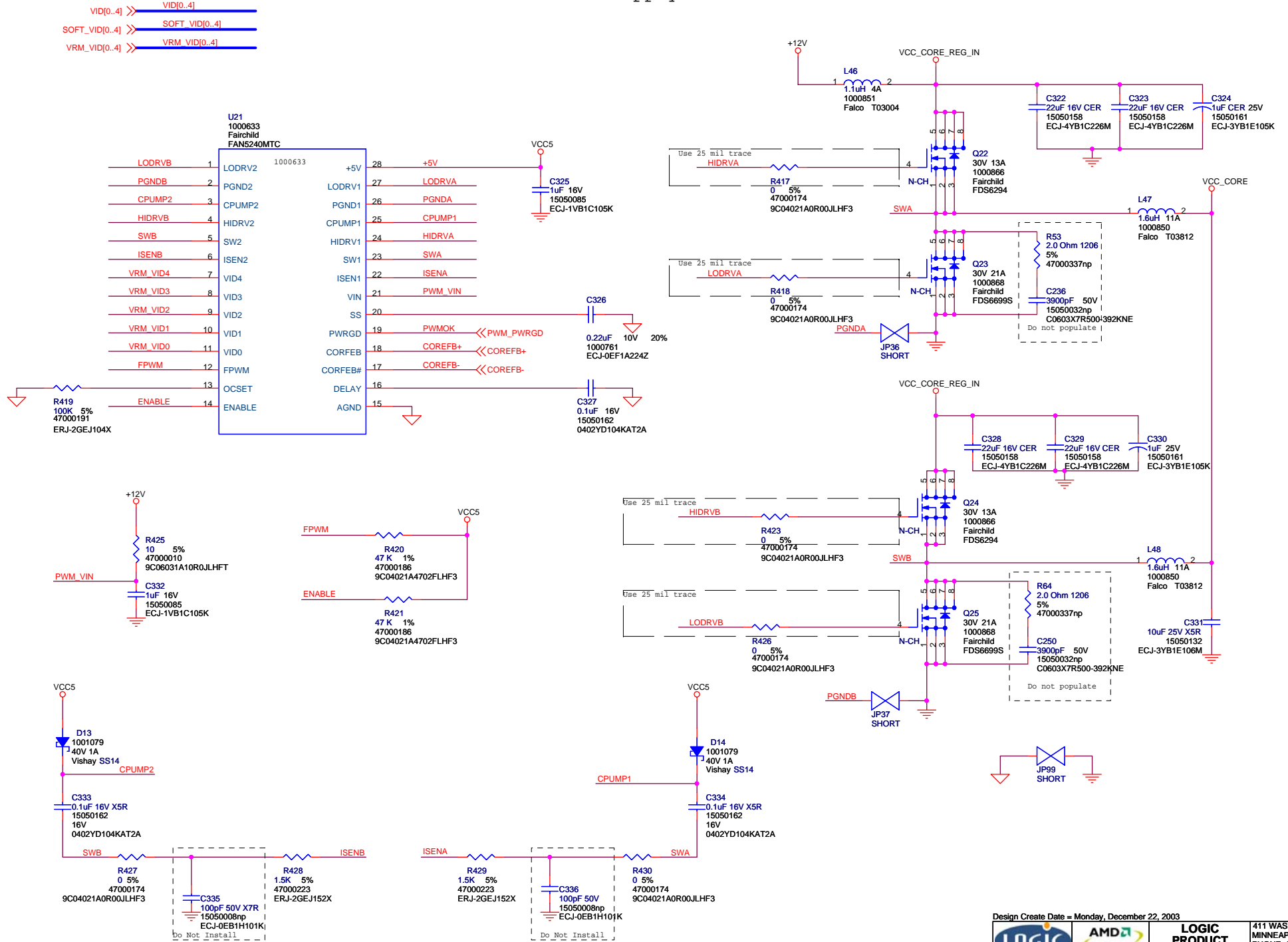

Notes:

CPU VID outputs are hardwired on the processor package.
 CPU SOFTVID outputs are register outputs of the processor.

VIDs drive the PWM regulator at power-up because the SOFTVIDs are not stable. After the POWERGOOD signal has been asserted, the SOFTVID outputs are stable and the MUX drives the PWM regulator with the SOFTVID outputs. The SOFTVID outputs can then be used to change CPU voltage to support AMD Power Now!(TM).

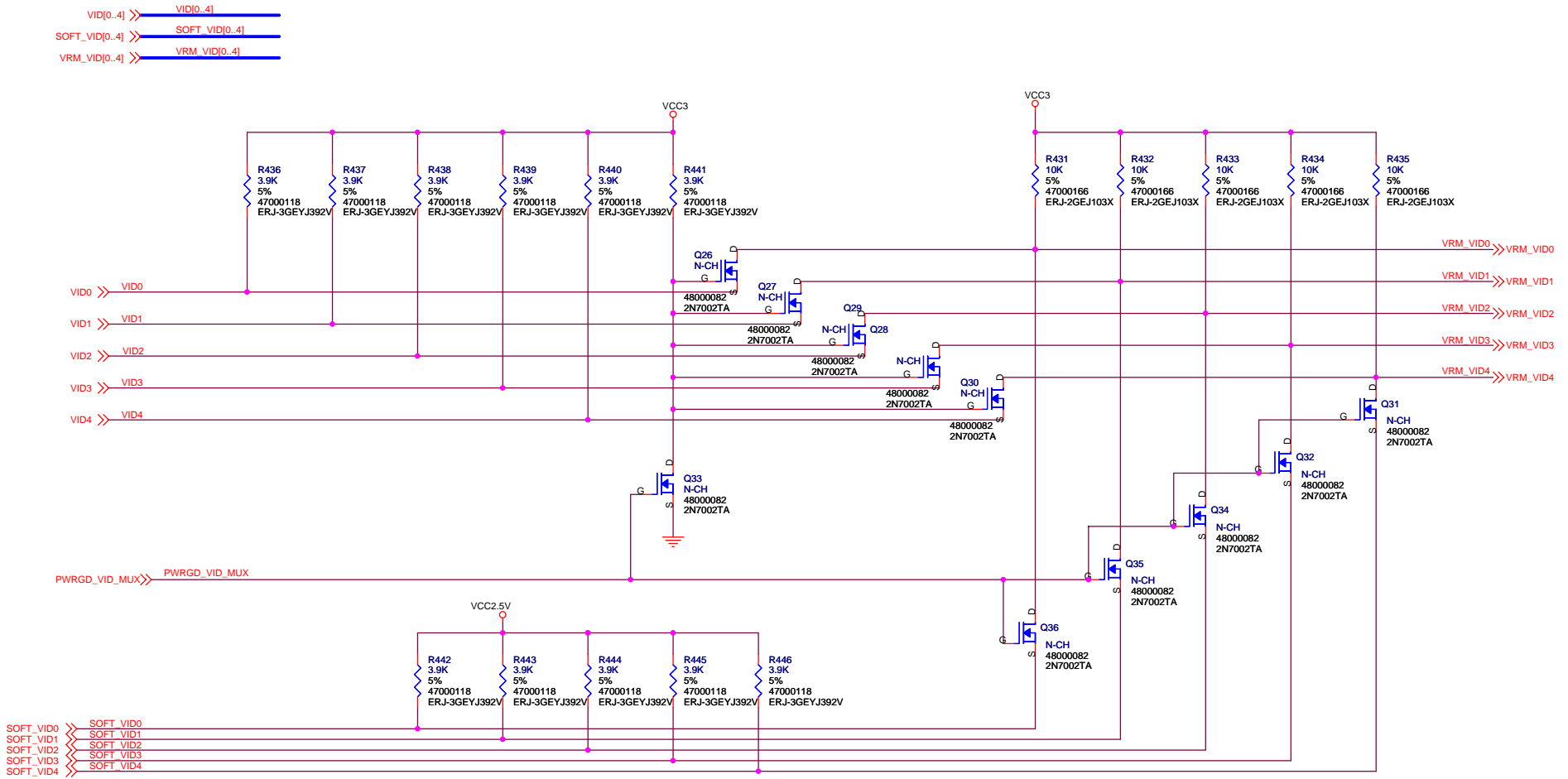

Design Create Date = Monday, December 22, 2003

		LOGIC PRODUCT DEVELOPMENT	411 WASHINGTON AVE. N MINNEAPOLIS, MN 55401 PHONE: (612) 672-9495 FAX: (612) 672-9489
Title Processor VID Mux		Rev 6	
SizeCustom	Number 1002124	Date Friday, January 13, 2006	
Project AMD Geode NX		Sheet 41 Of 43	

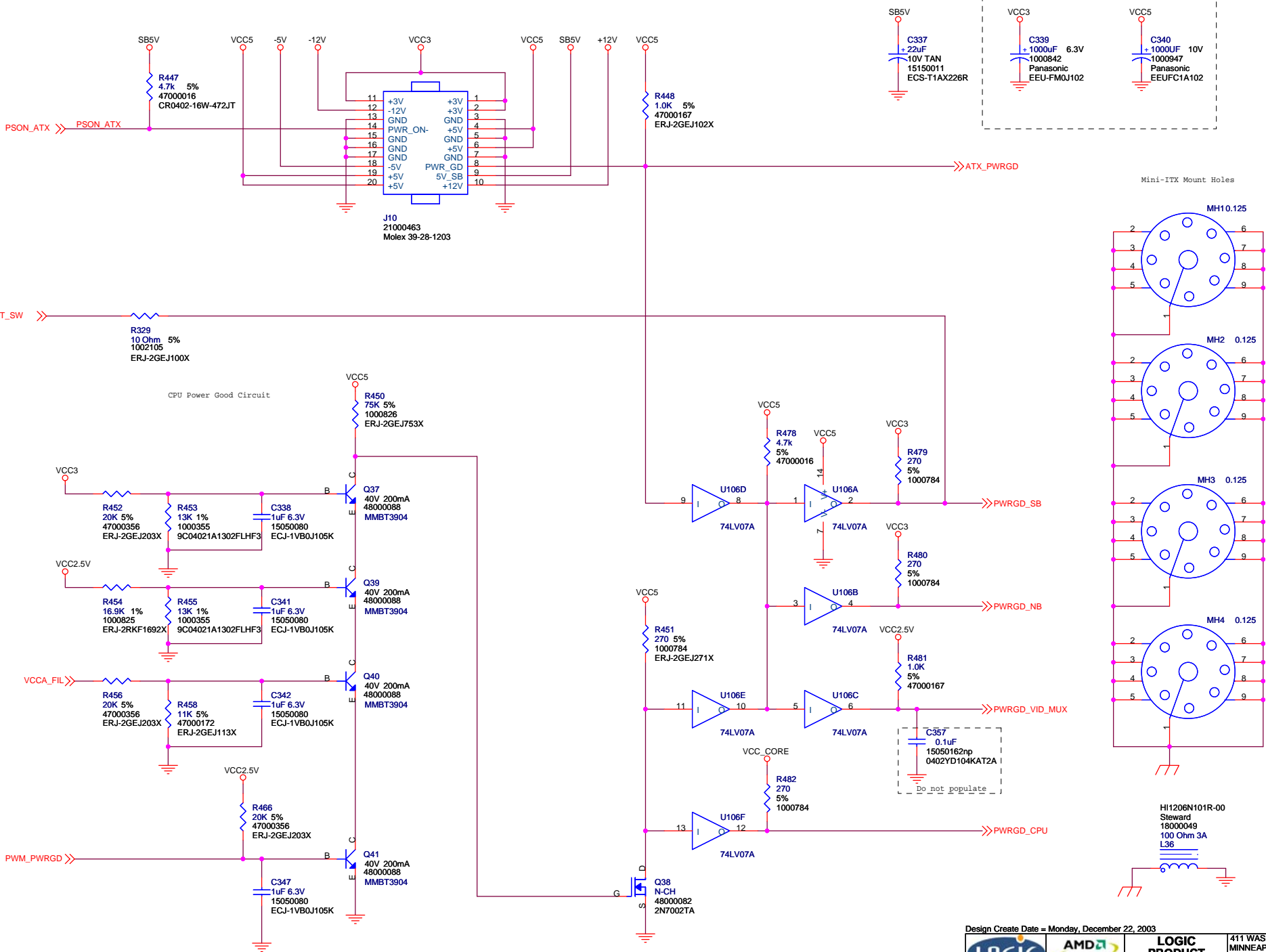

Design Create Date = Monday, December 22, 2003

		LOGIC PRODUCT DEVELOPMENT	411 WASHINGTON AVE. N MINNEAPOLIS, MN 55401 PHONE: (612) 672-9495 FAX: (612) 672-9489
Title POWER CONNECTOR			
SizeB	Number 1002124	Rev 6	
Date Friday, January 13, 2006	Project	AMD Geode NX	Sheet 42 Of 43

Signal Name	741CX Ball Number	VB Remap Pin
AREQ#	E10	VBCAD
RBF#	C9	VBHCLK
WBF#	C8	VGPIO2
PIPE#/ADBIH	B8	VGPIO3
SBA0	D7	VBCLK
AAD31	A3	VBVSYNC
AAD30	B4	VBHSYNC
AAD29	D6	VBCTL1
AAD28	B2	VBCTL0
AAD27	D4	VBDE
AAD26	C3	VAD3
AAD25	D3	VAD2
AAD24	C2	VAD0
AAD23	E5	VAD1
AAD22	E1	VBD9
AAD21	E4	VBD8
AAD20	F3	VBD10
AAD19	F5	VBD11
AAD18	F2	VAHSYNC
AAD17	G6	VAVSYNC
AAD16	G3	VADE
AAD15	J3	VAD11
AAD14	K4	VAD10
AAD13	J2	VAD9
AAD12	L4	VAD8
AAD11	L5	VAD7
AAD10	M6	VAD4
AAD9	K3	VAD5
AAD8	M5	VAD6
AAD7	N6	VBD0
AAD6	M3	VBD1
AAD5	N4	VBD2
AAD4	M2	VBD3
AAD3	P5	VBD4
AAD2	N3	VBD5
AAD1	P4	VBD6
AAD0	N1	VBD7
AD_STB1	E2	VBGCLK
AD_STB1#	D1	VBGCLK#
AD_STB0	L1	VAGCLK
AD_STB0#	L2	VAGCLK#

TFT 40-PIN CONNECTOR

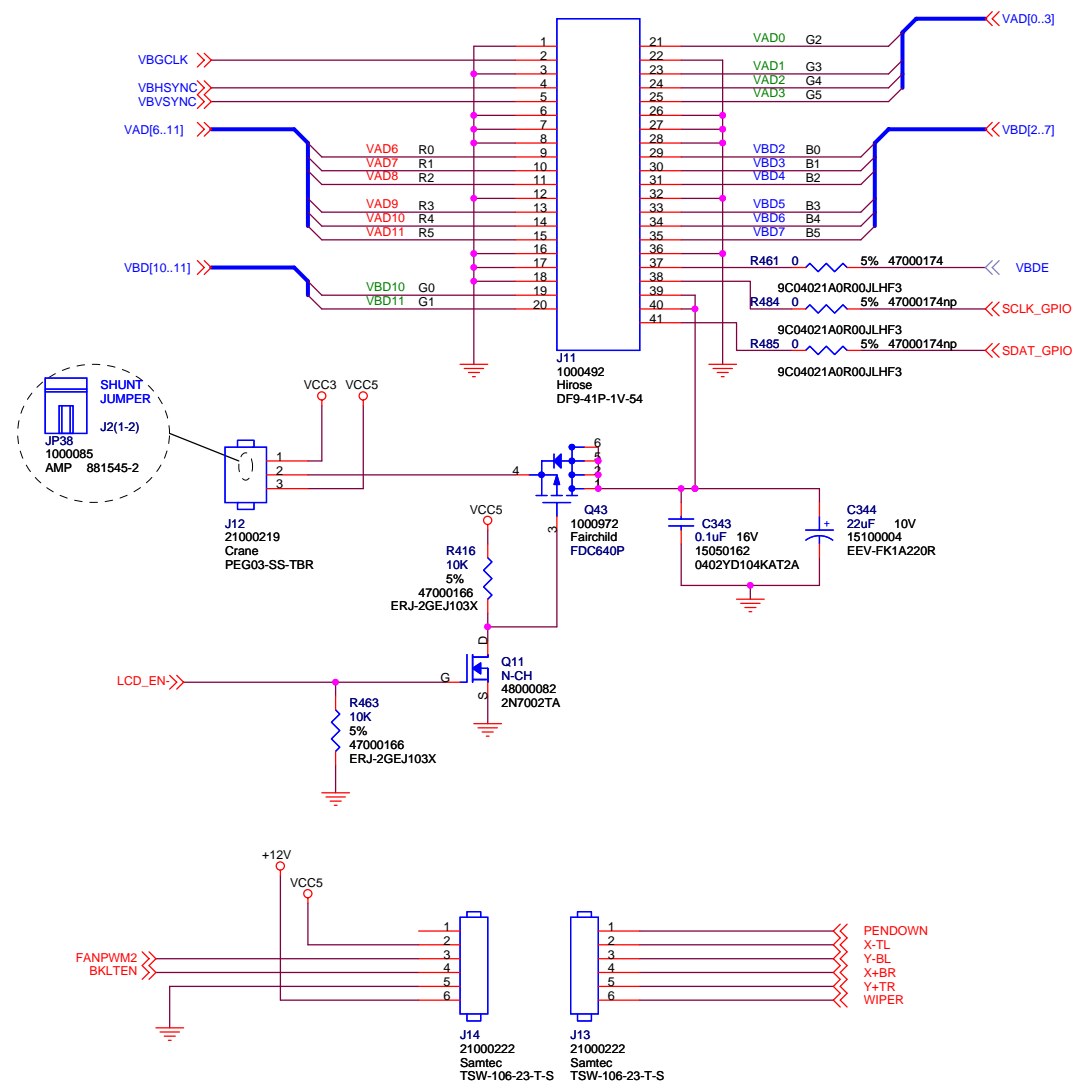

This sheet will contain the connectors described in the "Geode Platform Video Module Standard" presentation.

Design Create Date = Monday, December 22, 2003

		LOGIC PRODUCT DEVELOPMENT	411 WASHINGTON AVE. N MINNEAPOLIS, MN 55401 PHONE: (612) 672-9495 FAX: (612) 672-9489
			Title VIDEO BUS EXPANSION
SizeB	Number 1002124	Rev 6	
Date Friday, January 13, 2006	Project AMD Geode NX	Sheet 43 Of 43	