

F18 Thermometry Bridge



**Isotech North America
158 Brentwood Drive, Unit 4
Colchester, VT 05446**

**Phone: 802-863-8050
Fax: 802-863-8125**

**sales@isotechna.com
www.isotechna.com**

TABLE OF CONTENTS

1. INTRODUCTION.....	3
1.1. DEFINITIONS AND TERMINOLOGY USED IN THIS MANUAL	3
1.2. RANGE OF APPLICATIONS	4
1.3. OPERATOR CONTROLS	4
1.4. F18 ACCURACY	4
2. CONTROLS AND CONNECTIONS.....	6
2.1. FRONT PANEL	6
2.1.1. Bridge Resistors	6
2.1.1.1. R_s	6
2.1.1.2. R_t	6
2.1.2. Earth Connection	7
2.1.3. Source Impedance.....	8
2.1.4. Frequency.....	8
2.1.5. Gain	8
2.1.6. Gain (Potentiometer)	9
2.1.7. Carrier.....	9
2.1.8. Check.....	9
2.1.9. Meter Select.....	9
2.1.10. Bandwidth.....	9
2.2. REAR PANEL	12
2.2.1. AC Power Input Socket.....	12
2.2.2. Supply.....	12
2.2.3. Skt 1: Analogue Output.....	12
2.2.4. Skt 2: Analogue Output.....	13
2.2.5. IEEE-488 Interface	13
3. INITIAL OPERATION	14
3.1. POWER SUPPLY CONNECTION	14
3.1.1. Setting the Voltage and Fuse Rating.....	14
3.2. INITIAL CHECKOUT	14
4. THEORY OF OPERATION.....	16
4.1. BASIC PRINCIPLES OF OPERATION	16
4.2. CARRIER GENERATOR	17
4.3. PRECISION RATIO TRANSFORMER	17
4.4. ACTIVE GUARD CIRCUIT.....	18
4.5. GAIN CONTROLLER AMPLIFIER	18
4.6. LOW NOISE PRE-AMPLIFIER	18
4.7. THE DETECTORS	19
4.8. IN-PHASE DETECTOR.....	19
4.9. QUADRATURE DETECTOR	19
4.10. RESIDUAL DETECTOR	20
4.11. AUTOMATIC QUADRATURE SERVO.....	20
4.11.1. Introduction.....	20
4.11.2. Effects of Quadrature.....	20
4.11.3. Quadrature Servo Range.....	21
4.11.4. Choosing the Correct Quadrature Range.....	22
4.12. THE INTERNAL AUTOMATIC BALANCE PROCEDURE.....	22

5. COMPUTER INTERFACES..... 23

5.1. GENERAL INFORMATION..... 23

5.2. IMPORTANT NOTES..... 23

5.3. DEVICE ADDRESS SELECTION (IEEE-488) 23

5.4. IEEE-488 IMPLEMENTATION 24

5.5. INTERFACE FACILITIES 25

 5.5.1. Introduction..... 25

 5.5.2. Description of Commands 26

5.6. OBTAINING A MEASUREMENT FROM THE F18 31

5.7. RETURNED DATA..... 32

5.8. USING THE STATUS QUERY COMMAND..... 32

5.9. OPERATION WITH A SWITCHBOX..... 32

6. SPECIFICATION..... 34

6.1. MEASUREMENT RANGE..... 34

6.2. DISPLAY RANGE 34

6.3. ACCURACY 34

6.4. RESOLUTION 34

6.5. SENSOR CURRENT 34

6.6. CARRIER FREQUENCY..... 34

6.7. BANDWIDTH 34

6.8. QUADRATURE..... 34

6.9. TEMPERATURE MEASUREMENT SPECIFICATION 35

6.10. RESOLUTION 35

6.11. ANALOGUE OUTPUT 35

6.12. BRIDGE SELF CHECK 35

6.13. ENVIRONMENT..... 35

6.14. COMMUNICATIONS 36

7. CLEANING AND MAINTENANCE..... 37

7.1. CLEANING 37

7.2. PREVENTIVE MAINTENANCE 37

7.3. GENERAL SAFETY WARNING 37

7.4. ROUTINE MAINTENANCE 37

8. ACCESSORIES AND OPTIONS 38

9. SERVICE AND WARRANTY 39

9.1. TECHNICAL SUPPORT 39

9.2. RETURNED INSTRUMENTS 39

9.3. DOCUMENTATION 39

9.4. REPAIR QUOTATIONS..... 39

1. Introduction

The Model F18 is a high precision AC bridge for measuring resistance ratio. Its outstanding accuracy and sensitivity is achieved by using very high precision ratio transformers in a null balance potentiometer configuration.

A wide range of operator controls is provided, making the F18 a very flexible instruments, whilst remaining simple and convenient to use.

The bridge can be balanced manually, or automatically under the control of an internal microprocessor. In addition, all controls plus some extra facilities, are accessible remotely via the F18 computer interface.

Overall system accuracy will depend on the quality of PRT or RTD used.

The bridge design is such that it can be connected to a number of different types of PRT or RTD. The system can be set up so that absolute, relative or differential temperature measurements may be made, even with long PRT or RTD leads.

Temperature Equivalents:

$$1 \text{ milli-degree C} = 0.001^{\circ}\text{C} = 1\text{m}^{\circ}\text{C} = 1\text{mK} = 1.8\text{m}^{\circ}\text{F}$$

$$1 \text{ milli-degree F} = 0.001^{\circ}\text{F} = 1\text{m}^{\circ}\text{F} = 0.56\text{mK} = 0.56\text{m}^{\circ}\text{C}$$

1.1. Definitions and Terminology used in this Manual

- i) $1^{\circ}\text{C} = 1\text{K}$
- ii) $1 \text{ mK (milli-Kelvin)} = 0.001^{\circ}\text{C}$ (one milli-degree Celsius)
- iii) Alpha, or α , is the temperature coefficient, or temperature sensitivity, of the wire used in PRTs or RTDs. Generally speaking, the higher the alpha value, the better the PRT or RTD. Alpha is only used for industrial PRTs.
- iv) Thermometers are regularly referred to with several alternative abbreviations as follows:
 - PRT (Platinum Resistance Thermometer)
 - Pt100 (PRT with nominally 100Ω resistance at 0°C)
 - RTD (Resistance Temperature Device)Platinum resistance thermometers may also be referred to as probes or sensors.
- v) System accuracy refers to the overall, combined accuracy of the F18 and the PRT in use.

1.2. Range of Applications

The F18 measures resistance ratios in the range 0 to 1.299 999 9. Any standard resistor in the range 0 to 100 ohms can be used, making the F18 suitable for most platinum and Rhodium-Iron thermometer types.

The F18 performance has been optimized for work with lower resistance, making it an indispensable tool for measuring the new higher temperature PRTs.

1.3. Operator Controls

Using the front panel controls, the operator can select a wide range of operating parameters.

- i) PRT current (including a $\times \sqrt{2}$ facility for measuring the probe self-heating effect)
- ii) Operating frequency (two frequencies provided)
- iii) Detector gain
- iv) Quadrature servo range
- v) Detector source impedance: 1, 10 or 100 ohms
- vi) Manual/automatic balance
- vii) Analogue output range (optional)

In addition, a 'Zero' and 'Unity' ratio check is provided as a convenient way of confirming correct and accurate operation of the bridge.

The front panel analogue meter can be used to indicate the in-phase detector output, the proportion of the quadrature servo output being used, and the amount of residual signal (noise and interference) when the bridge is balanced.

For further details of bridge operating parameters, see sections 2 and 4.

1.4. F18 Accuracy

The accuracy which can be achieved in resistance ratio measurement is limited by the accuracy of the precision PRT ratios which, for the F18 is ± 0.1 parts per million (ppm) ratio.

Other errors can be induced which may reduce the performance. The more important of these are:

- i) Lead resistance and capacitance
- ii) Lead dielectric losses
- iii) High quadrature e.g. PRT self inductance
- iv) Second order AC effects, PRT mutual inductance
- v) Interference: RF signals, supply sub harmonics

vi) Leakage currents to ground and across the PRT

The first four causes are due to AC Effects and are kept small by using a low operating frequency.

The F18 is provided with two frequencies so that any AC effects can be measured and evaluated.

Most interfering signals are rejected by substantial filtering in the F18 detector. Large amounts of radio frequency interference, however, can cause intermodulation products resulting in spurious signals at the carrier frequency. Careful screening may be necessary in such environments.

To reduce the effect of leakage currents to ground, the F18 incorporates an active guard circuit. For a detailed discussion, see section 4-4.

2. Controls and Connections

2.1. Front Panel

Figure 2-1 shows the F18 Front Panel.



Figure 2-1. Front Panel.

2.1.1. Bridge Resistors

2.1.1.1. R_s

Two co-axial connectors which supply the current drive and voltage sense to an external standard resistor.

2.1.1.2. R_t

Two co-axial connectors which supply the current drive and voltage sense to the resistor or PRT being measured.



WARNING

These are isolated connectors and are NOT to be used as earth connections.

NOTE! Always connect voltage (v) connectors before current (I), and disconnect 'I' before 'v'.

2.1.2. Earth Connection

It is recommended that long cables are screened, the screen being connected to this point only which is connected to the main instrument earth. See figure 2-2.

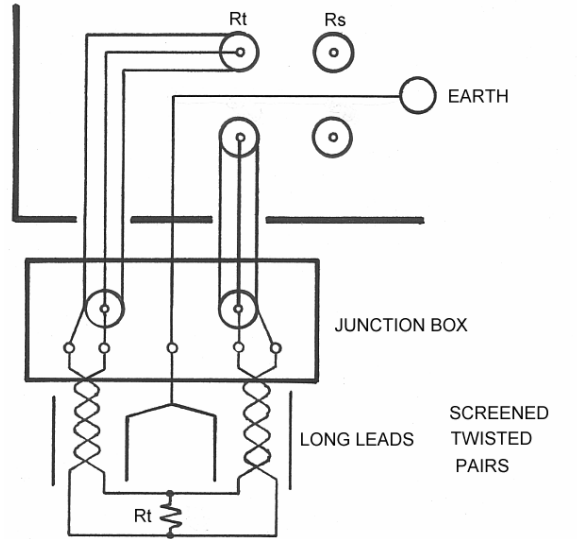

Figure 2-2. Recommended Connection for Long Leads.

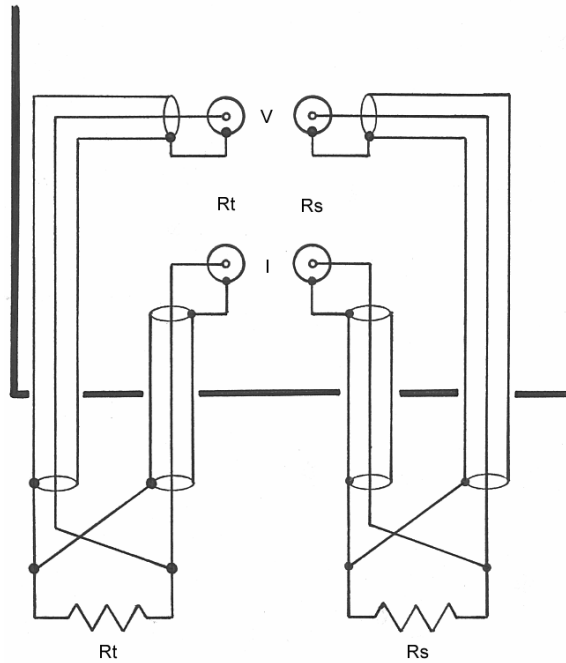

Figure 2-3. Four Terminal Connection to F18.

2.1.3. Source Impedance

This sets the noise impedance of the pre-amplifier. Optimum noise performance is achieved when this is equal to the source impedance, which can be calculated according to the formula in section 4.6.

Set as required. An LED indicates the value selected.

2.1.4. Frequency

The carrier frequency can be set to high or low by pressing the required button. The illuminated LED indicates the value selected. For more details, see section 4.2.

2.1.5. Gain

These four switches have a dual function:

- a) In-phase gain
- b) Reference amplifier gain, equivalent to quadrature servo range.

The QUAD switch is a function key; when its LED is off, the main amplifier gain can be set and is indicated. If pressed the LED comes on and the quadrature gain can be set.

Examples:

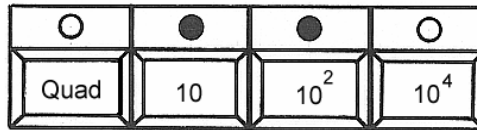

Figure 2-4. In phase detector gain = 10^3

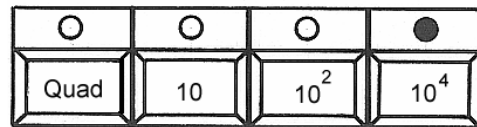

Figure 2-5. In phase detector gain = 10^4

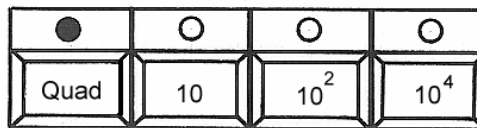

Figure 2-6. Quad gain = 1

The maximum useable gain of the in-phase detector is 10^2 .

The in-phase detector gain determines the meter sensitivity to out of balance signals.

The quad detector gain also determines the quadrature range. See Figure 4-7.

To set the in-phase gain correctly for automatic balance operation, see section 4.11.

2.1.6. Gain (Potentiometer)

Continuously variable from 0 to 10. Adjusts gain from x1 to x10.

For normal operation, set to x5, and check against transformer ratio taps, in manual mode. A one digit change in the sixth decade of the digital display should result in an out of balance of ten graduations on the lower meter scale with a gain of 10^4 .

The value of R_s and the R_t current setting are automatically taken into account when the F18 calculates the internal gain setting.

2.1.7. Carrier

A range of measuring currents is provided which caters for most types of PRT.

The $\times \sqrt{2}$ switch increases the selected operating current by $\times \sqrt{2}$ which can be used for checking PRT self heating.

2.1.8. Check

Bridge operation can be verified by selecting 'Zero' then 'Unity' checks.

Suitable resistors should be connected to R_t and R_s , with appropriate bridge settings.

The zero check will verify operation of the bridge input circuit, decade switching, D/A, quad servo, active guard circuit and the whole bridge balance circuit when the input voltage is set to zero. It will indicate whether any offset exists in the bridge balance circuit.

The unity check will verify operation of the bridge input circuit, the ratio transformer, the precision followers, decade switching, D/A, quad servo, active guard circuit and the whole bridge balance circuit by internally switching the the R_t potential leads across the R_s potential leads.

Any variation in the impedance of the input leads to the bridge input circuit can be shown by carrying out a complement check or by inserting a series resistance into each of the potential leads in turn.

Examples of zero, unity and complement checks are given in section 3.2.

2.1.9. Meter Select

The front panel meter can be used to indicate either:

- a) In-phase out of balance - both LEDs off
- b) Quadrature balance servo position - quad LED on
- c) Residual signals - residual LED on

In normal operation the meter is usually switched to indicate the in-phase out of balance.

2.1.10. Bandwidth

The three buttons on the right have a dual function, selected by the leftmost 'DAC' button which switches mode when pressed.

- a) D/A LED off

The bandwidth of the detector can be selected by pressing the required button. Three values are available: 0.5Hz, 0.1Hz and 0.02Hz.

b) D/A LED On

Three consecutive digits of the indicated ratio can be selected by pressing one of the three buttons on the right.

Three digits of the digital display are used to generate an output voltage, present at Skt 1.

A reading of 000 in the selected decades gives 0.00 volts and 999 gives 9.99 volts.

The three digits selected can be decades 345, 456 or 567.

When a button is pressed, the three selected digits remain on while the rest of the display blanks momentarily, indicating the chosen decades.

BRIDGE PARAMETER	PARAMETER SELECTION	FOR MORE DETAILS
SOURCE IMPEDANCE 1, 10, 100	Selected the source impedance to match the bridge output impedance, which depends on the standard resistor, PRT resistance and lead resistances.	Section 4.6
FREQUENCY Low, High	Set as required. Make measurements at both frequencies if AC effects are to be evaluated. The normal setting is 'HIGH'.	Section 4.2
GAIN (Switched) x1, x10, x10 ² x10 ³ , x10 ⁴	Set gain to achieve required resolution in manual or automatic modes. 10 ⁴ gives resolution of 0.1ppm 10 ³ gives resolution of 1ppm etc. The normal setting is 10 ⁴	Section 2.1.5
GAIN (Potentiometer)	For normal manual or automatic modes set to x5. Make fine adjust to x5. Make fine adjustments to optimize balancing in 'Auto' mode.	Section 2.1.6
REFERENCE AMP GAIN x10, x10 ² , x10	Also determines quadrature range. Set to a minimum which does not result in saturation of the quad servo. Check. that the reference amplifier is not saturated. See table 5.3. Normal setting x10.	Section 2.1.5 Section 4.11 Figure 4-7
CARRIER (Current)	Refer to PRT manufacturers' instructions. Select maximum carrier current which does not cause excessive self heating of PRT. Check self heating with x√2 facility.	
CHECK Zero, Unity	Use zero and unity checks only to confirm accurate operation, otherwise set for normal. Check self heating with x√2 facility.	Section 2.1.8
METER In-phase Quad residual	Use front panel meter to measure the amount of in-phase quadrature and residual signals coming through the detector. Normally set to in-phase. (Both LEDs off.)	Section 2.1.9
BANDWIDTH (Hz) 0.5, 0.1, 0.02	Set to the maximum bandwidth to achieve the required resolution in automatic balance mode. Does not affect manual operation.	Section 2.1.10

Figure 2-7. Bridge settings - Quick Reference Guide

2.2. Rear Panel

Figure 2.8. shows the F18 Rear Panel.

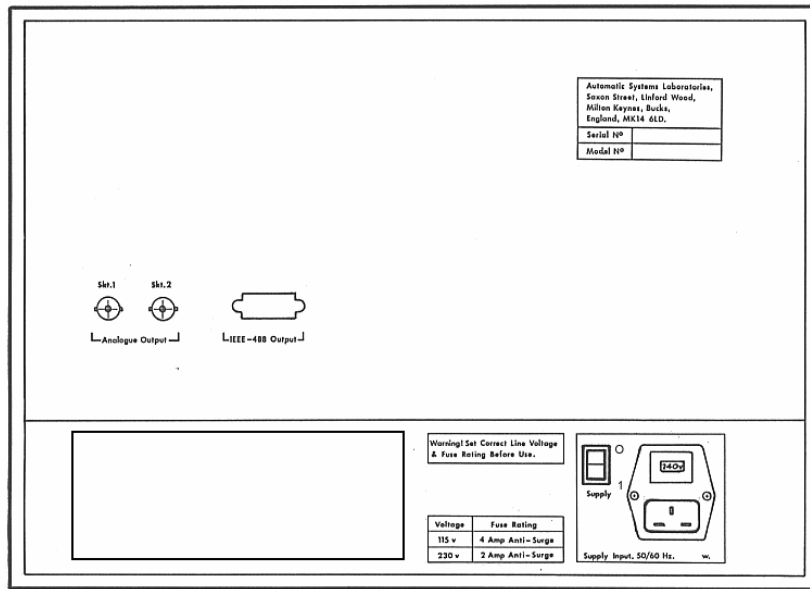

Figure 2-8. Rear Panel

2.2.1. AC Power Input Socket

The AC Power input unit incorporates a voltage selection tumbler, to enable the user to match the F18 to the local AC voltage supply, and two fuse holders. The correct 20mm fuses to install are as follows:

Voltage	Fuse
220/240V	T2A (250V AC) 2 Amp slow blow
100/120V	T4A (250V AC) 4 Amp slow blow

2.2.2. Supply

Power ON/OFF switch

I = Power ON O = Power OFF

The power switch itself will be illuminated (green), when the F18 power is switched ON. Care should be taken not to limit access to the power ON/OFF switch.

2.2.3. Skt 1: Analogue Output

Three consecutive digits of the indicated ratio are converted to an analogue form and scaled 0 - 9.99 Volts for 000 - 999. The required decades can be 567, 456 or 345 as selected from the front panel. See section 2.1.10.

2.2.4. Skt 2: Analogue Output

Output from the in-phase detector indicating the out of balance (bandwidth 1 Hz).

The sensitivity is determined by the 'Gain' select switches and 'Gain' control. See section 2.1.5 and 2.1.6.

2.2.5. IEEE-488 Interface

See section 5 for details.

3. Initial Operation

3.1. Power Supply Connection

Checking Voltage and Fuse Rating



WARNING: DO NOT CONNECT THE POWER CABLE OR SWITCH THE UNIT ON UNTIL THE VOLTAGE AND FUSE RATING OF THE INSTRUMENT HAVE BEEN CHECKED AND CHANGED IF NECESSARY.

The supply voltage setting of the F18 is shown on the power inlet socket on the rear panel. Check that this corresponds to the local voltage and that the fuse installed is as specified in section 2.2.1.

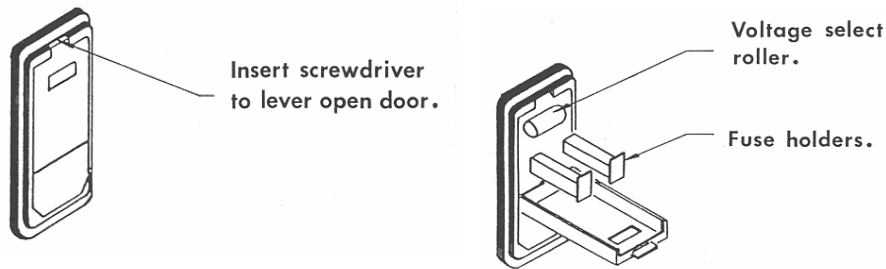

Figure 3-1. Power Input Unit and Fuse Rating Block.

3.1.1. Setting the Voltage and Fuse Rating

Lever open the power input unit from the top with a flat bladed screwdriver. Inside is a plastic cam: remove this and replace it so that the voltage to be set is displayed through the window.

Where fused power plugs are connected to the supply cable provided, the correct fuse rating is 3 Amps. The supply cable provided with the F18 is color coded as follows:

Ground	Green/Yellow (Protective Conductor Terminal)
Live	Brown
Neutral	Blue

3.2. Initial Checkout

When the correct supply setting has been checked to be correct, the instrument can be connected to the supply and switched on. Correct operation can be confirmed by using the following procedure.

Connect the two 100 ohm resistors (as supplied) to the R_s and R_t BNC inputs, as shown in Figure 3-2.

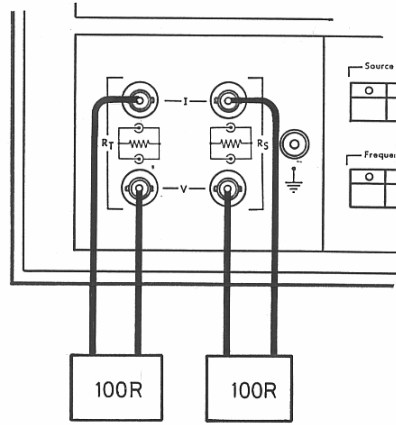

Fig. 3-2 Test Resistor Connections



WARNING Always connect voltage (v) and connectors before current (I), and disconnect 'I' before 'v'

When switched on, the instrument will default to the following settings:

- a) Source impedance: 100R
- b) Gain: 10^4
- c) Carrier: 1mA
- d) Frequency: HIGH
- e) Check: Normal (Zero and Unity off)
- f) Meter: In phase (Quad and Residual off)
- g) Bandwidth: 0.5Hz
- h) DAC: Decades 6 to 8
- i) Mode: Manual (Auto Off)

Set the fine gain control to 5.00 and press 'Zero Check' and 'Auto'. The bridge should automatically balance to 0.000 000 0.

Press the 'Unity Check' button. The bridge should automatically balance to 1.000 000 0 plus or minus one least significant digit.

Press the 'Unity Check' button again and the unit LED should extinguish, putting it in the normal measurement mode. The bridge should balance to a value which is the actual ratio R_T/R_S of the two resistors used.

Perform a 'complement' check by interchanging the R_T/R_S resistors. Allow the bridge to balance and calculate the reciprocal of the resultant ratio. This should agree with the first measured ratio within $\pm 0.4\text{ppm}$ or four least significant digits.

4. Theory of Operation

4.1. Basic Principles of Operation

The F18 is a high accuracy transformer bridge with a simple potentiometer configuration. The main elements of the bridge are:

- i) A carrier generator
- ii) Precision ratio transformer
- iii) Active guard circuit
- iv) Gain controlled amplifier
- v) In-phase detector
- vi) Automatic balance quadrature servo
- vii) Residual peak detector

The F18 uses a microcomputer to perform all the control and interface functions.

The carrier generator produces a low distortion sinusoidal constant current which flows equally through the standard, R_s , and R_t (PRT) resistors. See Figure 4-1.

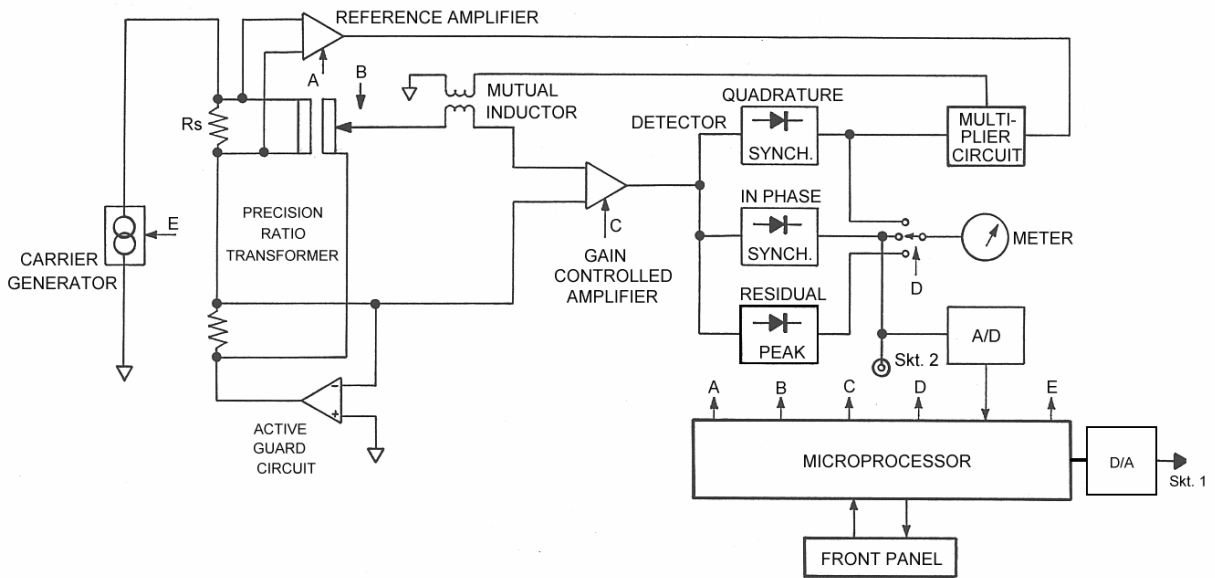

Figure 4-1. The F18 Potentiometer Configuration.

The voltages produced are therefore in exact ratio to the resistances. The voltage across the standard resistor, V_s , is applied to the primary of the high precision ratio transformer. The

voltage on the adjustable secondary is compared to the voltage across the unknown resistor, V_t , the difference being greatly amplified by the low noise, high gain detector.

The transformer ratio, n , is adjusted until the detector output is zero, whence:

$$\frac{R_t}{R_s} = \frac{V_t}{V_s} = n \text{ (the transformer ratio)}$$

The quadrature servo operates continuously to balance any reactive effects. See section 4.11.

The effects of lead resistance are eliminated by using a four terminal configuration.

The transformer has a very high input impedance, so that little current flows through the potential leads.

4.2. Carrier Generator

This consists of a stable, low distortion oscillator which produces a sinusoidal current which is phase locked to the supply frequency. One of the two frequencies can be set, via the front panel controls, making it possible to check spurious AC effects.

SUPPLY FREQUENCY (Nominal)	CARRIER FREQUENCY (NOMINAL)	
	LOW	HIGH
50Hz	25Hz	75Hz
60Hz	30Hz	90Hz

Figure 4-2. Carrier Frequency Selection

The choice of operating current is determined by the type of PRT used. A higher current results in greater resolution, but increased heat dissipation in the PRT. This self heating can be checked by using the $\times \sqrt{2}$ facility.

4.3. Precision Ratio Transformer

The three stage transformer is used to generate voltage ratios in the range 0.000 000 0 to 1.299 999 9.

The input impedance of the transformer, which appears across the standard resistor, is greater than 10^9 ohms.

For the transformer to work correctly, the standard resistor should be no more than 100 ohms. The voltage on the primary must also be limited, depending on operating frequency, due to saturation of the magnetic cores. See Figure 4-3 below.

CARRIER FREQUENCY	MAX VOLTAGE ACROSS R_s (VOLTS RMS)
Low	0.5

High	1.0
------	-----

Figure 4-3. Ratio Transformer Saturation Limits

4.4. Active Guard Circuit

See Figure 4-1.

This provides the necessary earth for the bridge circuit by maintaining one of the PRT potential leads at a 'virtual earth' without a physical connection to earth.

This has the advantage of reducing the effects of leakage currents to earth in, for example, high temperature applications.

4.5. Gain Controller Amplifier

This consists of a number of major elements:

- i) Low noise pre-amplifier
- ii) Extensive filtering to eliminate supply harmonics and other interfering signals
- iii) Adjustable gain stages - coarse and fine
- iv) Overload detection circuits.

4.6. Low Noise Pre-amplifier

The pre-amplifier consists of a low noise amplifier with adjustable impedance matching.

The input noise impedance can be selected to be 1, 10 or 100 ohms for optimum noise performance. Optimum performance is achieved when the detector input noise impedance is equal to the bridge output impedance. This is calculated as follows:

$$\text{Bridge output impedance} = (R_s + 2R_1)n^2 + R_t + 2R_2$$

Where R_s = Standard resistor value

R_1 = Standard resistor potential lead resistance

R_t = PRT resistance

R_2 = PRT potential lead resistance

n = Transformer ratio at balance

The resistance of the current leads have no effect.

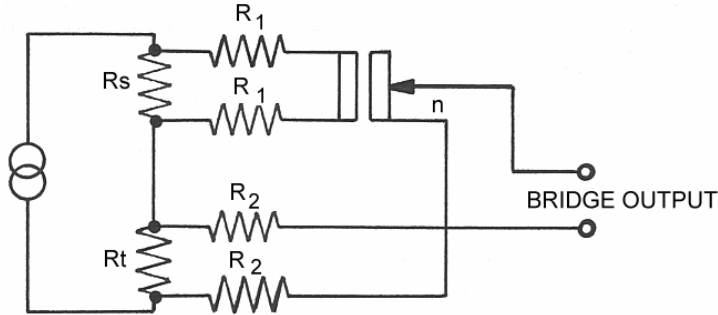

Figure 4.4 Bridge Output Impedance Calculation

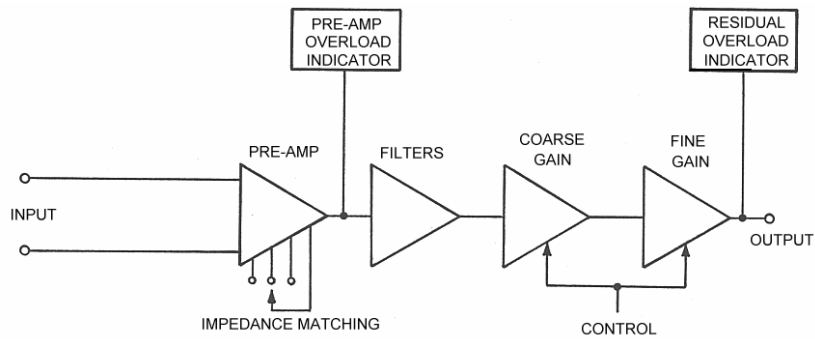

Figure 4.5 Gain Controlled Amplifier

4.7. The Detectors

See Figure 4-1.

The output of the gain controlled amplifier goes to three detectors:

- i) In-phase synchronous detector
- ii) Quadrature synchronous detector
- iii) Residual peak detector

4.8. In-Phase Detector

This converts any signal at the carrier frequency and in the same phase as the carrier current to DC indicating the bridge 'out of balance'. The output goes to the meter, connector Skt 1 on the back panel and also to an analogue to digital converter.

4.9. Quadrature Detector

This detects any signal at the carrier frequency and in quadrature (i.e. 90 deg phase shifted) to the carrier current. If any signal is present, the detector integrates, the output ramping up or down depending on the relative phase. The output controls the multiplier circuit and the front panel meter (when selected).

The quadrature detector forms part of the automatic quadrature servo loop. See section 4-11.

4.10. Residual Detector

This is a simple peak detector for checking the total signal present on the output of the main amplifier. The detector can be switched to the meter using the front panel controls.

4.11. Automatic Quadrature Servo

4.11.1. Introduction

Due to the presence of active elements in the standard (R_s) and PRT (R_t) resistors, the signals developed across them may not be in exactly the same phase.

The bridge is therefore balanced by adjusting the ratio of the transformer and injecting a quadrature signal, derived from the voltage across the standard resistor, until the outputs of both the in-phase and the quadrature detectors are zero.

The in-phase balance may be adjusted manually, using the front panel rotary switched, or automatically, under control of the internal microprocessor. Quadrature is balanced continuously, in manual or automatic mode, by the automatic solid state quadrature servo.

4.11.2. Effects of Quadrature

If the standard and PRT (complex) impedances are $R_s + iQ_s$ and $R_t + iQ_t$ respectively, then the condition for full balance is:

$$nI(R_s + iQ_s) - I(R_t + iQ_t) + KI(Q_s + iR_s) = 0 \text{ volts} \quad \text{---- (1)}$$

where n = transformer ratio

I = operating current

K = a factor indicating the amount of quadrature which is injected to achieve a null.

Note that the quadrature is $I(Q_s + iR_s)$ as it is derived from the voltage across the standard resistor and shifted in phase by 90 deg through the mutual inductor.

The bridge current cancels, whence, considering the real and imaginary parts:

$$R_s - R_t + K Q_s = 0 \quad \text{---- (2)}$$

$$Q_s - Q_t - K R_s = 0 \quad \text{---- (3)}$$

Substituting for K in (1) gives

$$\frac{R_t}{R_s} = n + \frac{Q_t Q_s}{R_s^2} - n \frac{Q_s^2}{R_s^2}$$

Since Q_t and Q_s are always small compared with R_t and R_s , then

$$\frac{Q_t}{R_t} = \theta_t \quad \text{-PRT impedance phase angle (radians)}$$

$$\frac{Q_s}{R_s} = \theta_s \quad \text{-standard resistor phase angle (radians)}$$

$$\frac{R_t}{R_s} \cong n$$

$$\frac{R_t}{R_s} = n (1 + \theta_t \theta_s - \theta_s^2)$$

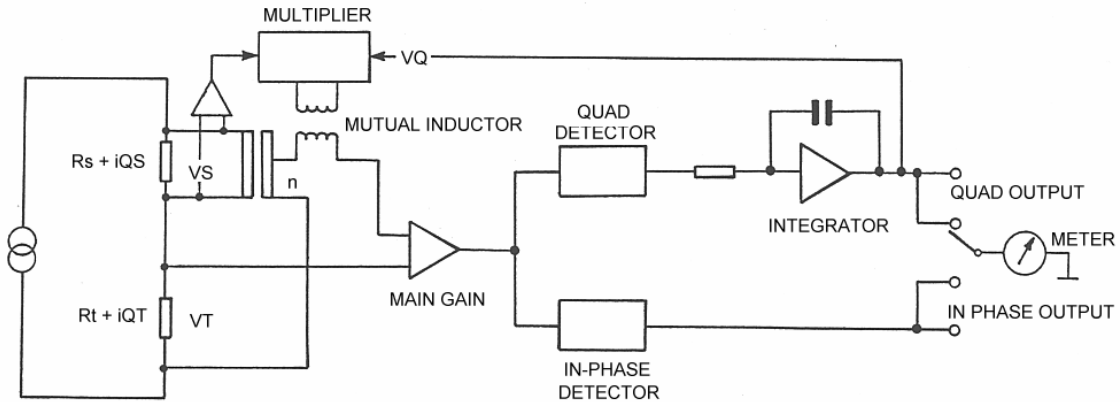

Figure 4.6 Quadrature Servo

4.11.3. Quadrature Servo Range

The amount of quadrature that can be compensated is limited by the range of the quad servo, equivalent to a maximum value for K . The output voltage, V_Q , of the quad servo, as presented to the meter, indicates the amount of quadrature present on the bridge, i.e. proportional to K :

from (3)
$$K = \frac{Q_t}{R_s} - \frac{Q_s}{R_s}$$

or
$$K = (\theta_t - \theta_s)$$

The maximum range is determined by the gain, G_1 , of the reference amplifier as indicated in Figure 4-7. The limit on V_S is due to saturation of the ratio transformer or reference amplifier.

QUAD	Quadrature Range	Maximum
------	------------------	---------

GAIN	VQ = ± Full Scale on Meter	VS Allowed
Front Panel Selected	K Max - See Section 4.11.2	VS = I.R _s
1	± 2 x 10 ⁻⁵	Limited by saturation of ratio transformer. See Fig 4-3
10	± 2 x 10 ⁻⁴	100mV RMS
10 ²	± 2 x 10 ⁻³	10 mV RMS

Figure 4-7. Quadrature Servo Range.

4.11.4. Choosing the Correct Quadrature Range

The minimum quad gain (and hence quadrature range), which does not result in saturation of the quadrature servo, should be used. If excessive quad gain is used, this can result in longer balance times in automatic mode.

4.12. The Internal Automatic Balance Procedure

When automatic balance is selected, the internal microprocessor measures the out of balance and sets the ratio transformer in order to achieve a null. This is carried out one decade at a time; the gain of the main amplifier being increased by a factor of ten for each decade until it reaches the gain selected by the front panel.

If at any time the out of balance is too great, the gain is progressively decreased until the out of balance can be corrected, and the gain progressively increased again to the selected value.

Since the out of balance is measured, the optimum automatic balancing requires the correct gain. This is set nominally by the front panel switches, but a fine adjustment is provided by the ten turn potentiometer. This should be set to approximately 5.0 (five turns) for correct automatic operation.

The fine adjustment can be used to facilitate very sensitive out of balance measurements in the manual mode.

5. Computer Interfaces

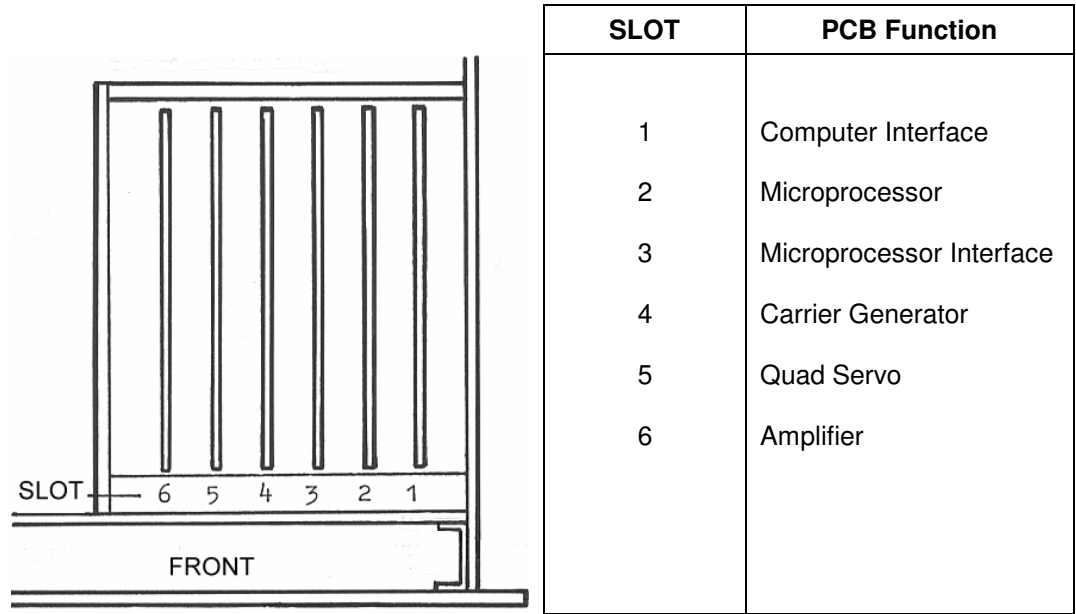

Figure 5-1. F18 Card Frame (Top View)

5.1. General Information

The F18 is supplied with an IEEE-488.1 interface

5.2. Important Notes



- i) The Interface OV, for IEEE-488 is connected to ground (supply - Green lead), internally to the F18.
- ii) Switch off power to all instruments, peripherals or computer(s) associated with the F18 interfaces, before connecting the F18 or disconnecting the F18 from the Interface.

EQUIPMENT DAMAGE MAY RESULT IF THIS IS NOT COMPLIED WITH.

5.3. Device Address Selection (IEEE-488)

This switch is also used to set the device address for the IEEE-488 interface. See figure 5.2.

UNLESS OTHERWISE DIRECTED, ASL SETS THE IEEE-488 ADDRESS TO 4.

Any device address in the range 1 to 15 inclusive may be selected.

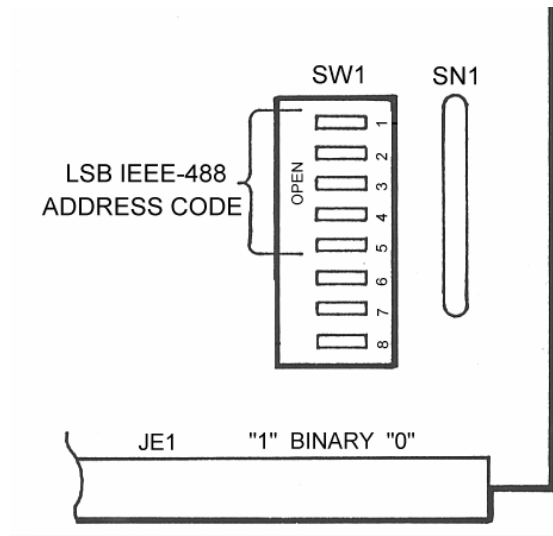

Figure 5-2. IEEE Address Code Select Switch

5.4. IEEE-488 Implementation

The F18 IEEE-488 interface includes the following subsets of the IEEE-488.1 :1987.

- | | | |
|-------|-----|-------------------------------------------------------|
| i) | SH1 | Full source handshake |
| ii) | AH1 | Full acceptor handshake |
| iii) | T8 | Basic talker (unaddress on MLA) |
| iv) | L4 | Basic Listener (unaddress on MLA) |
| v) | LEO | No extended address |
| vi) | TEO | |
| vii) | SR1 | |
| viii) | RLO | No remote/local function (similar function available) |
| ix) | PPO | No parallel poll |
| x) | DC1 | Device clear - reverts to power-on state |
| xi) | DTO | No group executive trigger |
| xii) | C0 | No controller functions |

For a fuller explanation, consult the IEEE-488.1 : 1987 standard and your computer/controller interface manual.

5.5. Interface Facilities

5.5.1. Introduction

The IEEE-488 interface allows commands to be sent to, and data retrieved from the F18 in the form of ASCII characters and strings.

Figure 5-3 below summaries the available commands and the required syntax.

COMMAND	DESCRIPTION
AU	Set auto balance mode
B	Set bandwidth
C	Set carrier current
CHK	Set check mode
DAC	Set DAC (analogue o/p) range
FRQ	Set carrier frequency
G	Set gain
MAN	Set manual balance mode
MET	Set meter mode
OFL	Switch bridge off-line
ONL	Switch bridge on-line
P	Preset ratio on bridge
PA	Preset ratio to current auto ratio
REF	Set ref amp gain (Quad range)
SRC	Set source impedance
SRM	Set mask for GPIB Service Request Function

Figure 5-3. Summary of Available Commands

The F18 controls can be set either from the front panel (in the off-line mode) or from remotely set values via the interface (in the on-line mode).

To achieve this, the F18 stores two sets of values, one from the front panel, the other from commands via the interface, and uses the values as determined by the on-line (ONL) and off-line (OFL) command.

The off-line front panel controls may be changed while the F18 is on-line, but the bridge will not respond to these until the F18 is set off-line. Similarly, the on-line settings may be changed via the interface while the bridge is off-line, but these will not take effect until the F18 is set on-line.

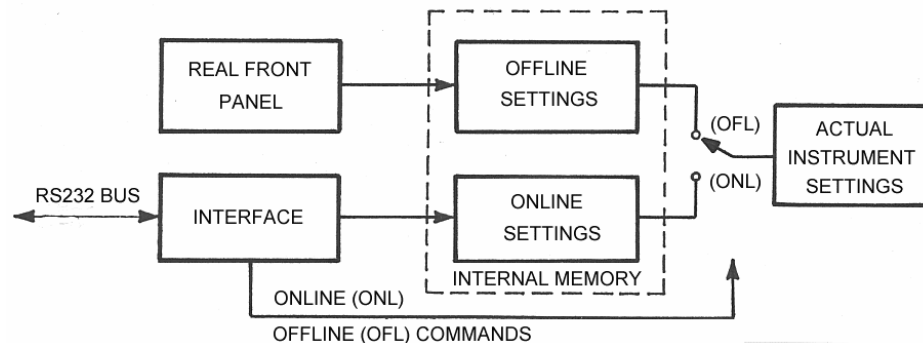

Figure 5-4. Schematic Representation of Remote Control Facilities

5.5.2. Description of Commands

AU

DESCRIPTION: This instruction puts the bridge in auto balance mode

SYNTAX: AU

PARAMETERS: None

B

DESCRIPTION: This instruction selects the detector bandwidth

SYNTAX: Bc

PARAMETERS: c is a code between 0 and 2

0 is 0.5Hz

1 is 0.1Hz

2 is 0.02Hz

INITIAL VALUE: 0 (0.5Hz)

C

DESCRIPTION : This instruction selects the bridge current

SYNTAX: Cc

PARAMETERS: c is a code between 0 and 8 or 10 and 18

0 is a current of 0.1mA

1 is a current of 0.2mA

2 is a current of 0.5mA

3 is a current of 1.0mA

4 is a current of 2.0mA

5 is a current of 5.0mA

6 is a current of 10.0mA

7 is a current of 20.0mA

8 is a current of 50.0mA

10 through 18: same as 0 through 8 but $\times\sqrt{2}$ mA

INITIAL VALUE: 3 (1mA)

CHK

DESCRIPTION: This instruction sets the check mode

SYNTAX: CHKc

PARAMETERS: c is a code between 0 and 2

0 is normal operation

1 is zero check

2 is unit check

INITIAL VALUE: 0 (no check)

DAC

DESCRIPTION: This instruction sets the analogue output range

SYNTAX: DACc

PARAMETERS: c is a code between 0 and 3

0 is range digit 3 to digit 5

1 is range digit 4 to digit 6

2 is range digit 5 to digit 7

INITIAL VALUE: 2 (digits 5 through 7)

FRQ

DESCRIPTION: This instruction sets the carrier frequency

SYNTAX: FRQc

PARAMETERS: c is a code of 0 or 1

0 is low frequency

1 is high frequency

INITIAL VALUE: 1 (high frequency)

G

DESCRIPTION: This instruction sets the gain of the bridge

SYNTAX: Gc

PARAMETERS: c is a code between 0 and 5

0 is a gain of 10^0

7 is a gain of 10^5

INITIAL VALUE: 0 (gain of 1)

MAN

DESCRIPTION: This instruction puts the bridge in manual balance mode

SYNTAX: MAN

PARAMETERS: None

MET

DESCRIPTION: This instruction selects the meter mode

SYNTAX: METc

PARAMETERS: c is a code between 0 and 2

0 is out of balance reading

1 is quadrature reading

2 is residual reading

INITIAL VALUE: 0 (out of balance indication)

OFL

DESCRIPTION: This instruction switches the bridge off-line. Instructions may still be sent, but the bridge is controlled from the front panel switches, and the instructions will not be actioned until the ONL instruction is sent. See section 5.5.1 and Figure 5-4.

SYNTAX: OFL

PARAMETERS: None

ONL

DESCRIPTION: This instruction allows the bridge to be controlled from the external interface, as opposed to being controlled from the front panel switches. See section 5.5.1 and Figure 5-4.

SYNTAX: ONL

PARAMETERS: None

P

DESCRIPTION: This instruction allows a ratio to be preset on the bridge.

SYNTAX: Pn

PARAMETERS: n is a ratio between 0 and 1.299 999 9

INITIAL VALUE: 0.000 000 0

PA

DESCRIPTION: This instruction sets the current ratio in auto balance mode to be preset on the bridge. The bridge is then put into manual balance mode.

SYNTAX: PA

PARAMETERS: None

INITIAL VALUE: The current ratio in auto balance mode

Q

DESCRIPTION: This instruction returns the current bridge status.

SYNTAX: Q

PARAMETERS: Returned parameters represent the same values as those sent with each command.

REF

DESCRIPTION: This instruction selects the reference amplifier gain (quad range)

SYNTAX: REFc

PARAMETERS: c is a code between 0 and 2

0 is a gain of 1 quad range 2×10^{-5}

1 is a gain of 10 quad range 2×10^{-4}

2 is a gain of 100 quad range 2×10^{-3}

INITIAL VALUE: 0 (Gain of 1)

SRC

DESCRIPTION: This instruction selects a source impedance

SYNTAX: SRCc

PARAMETERS: c is a code between 0 and 2

0 is source impedance: 1 ohm

1 is source impedance: 10 ohms

2 is source impedance: 100 ohms

INITIAL VALUE: 1 (source impedance: 10 ohms)

SRM

DESCRIPTION: This instruction allows the user to set a mask for the GPIB service a request function.

SYNTAX: SRMc

PARAMETERS: C is a number between 0 and 255 forming a bit wise mask.

The functions of the bits are as below:

Bit 7	Bit 6	Bit 5	Bit 4	Bit 3	Bit 2	Bit 1	Bit 0
Data available	Request Service bit	Not balanced	Balanced	Overload error	Not used	Not used	Not used
V=128	V=64	V=32	V=16	V=8	V=4	V=2	V=1

Bit 7: When set, will request service whenever the ratio is updated.

- Bit 6: When a serial poll is performed on the F18, this bit is set indicating that the F18 was the source of the interrupt.
- Bit 5: When set, will request service even if the F18 is not balanced.
- Bit 4: When set, will request service when the F18 is balanced.
- Bit 3: When set, will request service when a bridge overload error has occurred.

When a serial poll is performed on the F18, the status byte returned is in the same form as the mask shown above.

Setting a mask causes a request service function to be generated whenever the bridge condition corresponds with the service mask which has been set.

Bit 6 (request service bit) and the bit which corresponds with the mask condition will be set and will be returned in the byte returned by the serial poll.

INITIAL VALUE: 0 (no mask set)

5.6. Obtaining a Measurement from the F18

All commands sent to the F18 must be in upper case letters and must be terminated by a line feed (ASCII 10) character.

Data returned by the instrument is terminated by carriage return (ASCII 13) and line feed (ASCII 10) characters.

Standard factory set address is 4. The IEEE address may be altered by the operator via the switch on the interface card fitted within the F18.

There two methods of getting data back from the instrument:

- a) No output command is required

A standard reading followed by the balance status letter may be requested simply by instructing the IEEE controller to read a number of bytes. The length of the standard reading is 15 bytes including CR and LF delimiting characters. Therefore this is the recommended number to read. Requesting fewer bytes will return an incomplete string. Requesting more bytes will return only one standard reading, because the F18 is set up to terminate communication on sending the line feed character (ASCII 10).

- b) Send "SRMc" command ,where "c" is a number between 0 and 255, to set up a service request (SRQ) function on the F18, which may be serial polled by the controller to establish whether the service request condition has been met. The most common value for "c" will be "128" (bit 7), i.e. the instrument will request service when the ratio reading is updated on completion of the balance cycle.

It has generally been found to be more reliable to disable the auto serial poll function on the IEEE controller and for the program to perform a serial poll of the RSV bit periodically to establish whether data is available for output. If the request service bit is set, send interface bus read command to read the data, as in (a).

The bridge must be set "on-line" before using the interface, because the F18 stores two sets of bridge operating parameters: one for "on-line" operation via the interface and one for local operation via the front panel.

When a scanning/logging sequence is set up in a PC program, it is normal to set local lockout (LLO) to prevent the front panel controls of the instrument from being accidentally altered while the scan/log is in progress.

Note:

Sending a preset value to the bridge using the "P" or "PA" commands will automatically set the bridge into manual balance mode. To reset the bridge to automatic balance mode via the interface, use the "AU" command.

The "AU" command has no parameters. To set the bridge to manual balance mode, use the "MAN" command.

5.7. Returned Data

13 digits + CR + LF are returned in the form "+1.234567890B" + CR + LF, the first digit being the sign and the last, the bridge balance status. Bridge balance status may be "B", "L" or "H" or "E": for balanced, low, high or error (overload condition).

Only the first 8 figures after the decimal point are significant.

Data can be retrieved from the output buffer once per balance (program) cycle, which may be two seconds or more, depending on the signal being measured.

5.8. Using the Status Query command

Send the command "Q" + CR + LF.

The status query command provides a positive indication that commands sent or bridge parameters changed have been acted upon. It also allows a check on current bridge status on the occurrence of errors.

The data returned is a string of 72 bytes including carriage return and line feed characters. It may be interpreted in the same way as the commands sent to control the bridge (see section 5.5.2).

5.9. Operation with a Switchbox

The switchbox system requires both an SB158 switchbox controller and up to six 10 channel SB148 switchboxes to provide a maximum of 60 channels.

Up to four external R_s (reference resistor) channels may be defined in hardware (factory set) on channels 6 to 9 of 148 switchbox number 0. Once defined, these channels may be used only for R_s . Where less than four R_s channels are defined, they are numbered downwards from 9, i.e. one R_s channel only will be set on channel 9, two R_s channels will be set on channels 8 and 9 and so on.

Standard factory set address for the switchbox controller is 7. The IEEE address may be altered by the operator via the switch on the interface card. (refer to the Switchbox Operator's Handbook).

Ports I, L, M, O on the switchbox IEEE card are used to set the channel number. Ports I, L, M are used to set the R_t channel, port O is used to set the R_s channel number. Port L represents hundreds, I represents tens, M represents units, O represents the R_s channel number. For example, the command "L0I5M6O9" sets R_t channel 56, R_s channel 9.

Data is not normally read back from the switchbox controller, except to verify that a switchbox controller is present and on-line.

6. Specification

6.1. Measurement Range

Measurement range: 0 to 260 ohms

Rated accuracy: 0 to 130 ohms

R_s range: 1 to 200 ohms.

6.2. Display Range

Display range of 0 to 1.2999999 ratio of two resistors, R_t & R_s .

6.3. Accuracy

0.1 ppm ratio error.

6.4. Resolution

Typically $0.3nV\sqrt{Hz}$ rms at 1 ohm matching impedance.

6.5. Sensor Current

1.0mA, 2.0mA, 5.0mA, $\times\sqrt{2}$, $\times 0.1$, $\times 10$ User selectable.

Sensor current accuracy 1%.

6.6. Carrier Frequency

50Hz local supply: Low 25Hz
High 75Hz

60Hz local supply: Low 30Hz
High..90Hz

Phase locked to the local supply frequency.

6.7. Bandwidth

Sets the bandwidth of detector.

0.5Hz, 0.1Hz, 0.02Hz User selectable.

6.8. Quadrature

At a frequency of 75Hz/90Hz the reactive component of most PRTs and standard resistors is insignificant and is rejected by the phase sensitive synchronous detector.

With higher values of R_t or R_s and long cables the quadrature component increases and may produce an in-phase error if a maximum is exceeded.

Quadrature can be minimized by using low resistance, low loss, low capacitance coaxial cables of equal length on R_t and R_s inputs.

6.9. Temperature Measurement Specification

The performance of the F18 as a temperature measuring instrument depends on the resistance PRTs used, and varies over the range. Maximum errors quoted in the PRT calibration certificate and reference resistor certificate, and the F18 errors must be added to give the combined accuracy figure.

6.10. Resolution

The digital resolution is typically 0.1 milli-degree with a Pt100 at 1mA.

The analogue output can be used for higher sensitivity measurements with a noise level of typically 10 μ K RMS using a Pt100 at 1mA.

6.11. Analogue output

Skt 1:	+10 Vdc max
Skt 2:	-10V to +10V dc max
Skt 2 Maximum Load:	10K, 10nf - 100m coax cable
Skt 2 Bandwidth:	1Hz

6.12. Bridge Self Check

Zero Self Check	Checks the bridge for any offset errors.
Unity Self Check	Checks the bridge for any unity scale errors.

6.13. Environment

Operating Temperature:	10°C to 39°C
Humidity:	Specified to 90% RH at 40°C non-condensing.
Power Requirements:	240 VAC \pm 10%, 220 VAC \pm 10% 120 VAC \pm 10%, 100 VAC \pm 10%
	Supply Voltage range is user selectable on rear panel.
Supply Frequency:	50 or 60 Hz. (see instrument rear panel)
Power consumption:	250 VA Max.

Dimensions:

	Cased	Rack Mounted
Width	527 mm (20.7")	483 mm (19")
Depth	459 mm (18.1")	430 mm(16.9")

Weight:

Cased	Rack Mounted
46 Kg (101 lbs)	35 Kg (77 lbs)

6.14. Communications

IEEE-488 Factory set to address 4.

7. Cleaning and Maintenance

7.1. Cleaning

Make sure the F18 is turned off and unplug the mains supply cable.

Clean the outside of the instrument with a soft, clean cloth dampened with mild detergent. Do not allow water to enter the instrument.



WARNING Never use alcohol or thinners as these will damage the instrument.

Never use a hard or abrasive brush.

7.2. Preventive Maintenance



WARNING Regular inspection of the mains supply cable is required to ensure that the insulation is not damaged.

7.3. General safety Warning



WARNING If the F18 is used in a manner not specified by ASL, then the protection provided by the instrument may be impaired.

7.4. Routine Maintenance

The F18 is tested and calibrated before dispatch, using special procedures and reference standards. It is not normally practical for customers to effect repairs.

Maintenance tasks are therefore limited to keeping the instrument and its leads clean. In particular the connectors for the resistors R_t and R_s should be kept clean to prevent leakage currents flowing. The outer of the BNC connectors and the cable braid are not at earth potential and should not be earthed. Damaged cable and connectors are a common cause of poor and intermittent operation.

8. Accessories and Options

The following accessories and options are available for the F18 Bridge:

FA-1	1 pair coaxial leads, BNC to BNC, 3 metres long
FA-2	1 pair coaxial leads BNC to open end, 3 metres long
FA-3	1 adaptor box (BNC to terminal and BNC)
FA-4	2 Terminal Binding Post to BNC - 2 OFF
T25-650-1	Standard reference PRT $R_o = 25.5$ ohms (nominal). 2 metre cable 4 wire plus screen with spade terminal connections. Stem length 450mm, quartz. R_{100}/R_o 1.3925 (min). Reproducibility 0.01K or better. Temperature range -189 to 650 °C
T100-650-1	Physically similar to T25-650-1, but with $R_o = 100 + 0.05$ ohms. Suitable for use in laboratory environments, but not for general industrial applications. Temperature range -189 to +650 °C.
T25-660-1	Secondary transfer standard PRT 25.5 ohm 4 wire with 4 metres connecting cable to spade terminals. Temperature range 0 to 650 °C
T100-450-2	Working reference PRT $R_o = 100$ ohms, 2 meter cable with spade terminals. Stem length 450mm stainless steel with quartz liner. Temperature range -100 to +450 °C. Alpha = 0.00385.
T100-450-3	As T100-450-2 except Alpha = 0.00392.
T100-600	Working reference PRT $R_o = 100$ ohms, 2 meter cable with spade terminals. Stem length 460mm quartz. Temperature range -50 to +600 °C. Alpha = 0.00385.
T0.25-962-1	High Temperature standards PRT. $R_o=0.25$ ohms. Temperature range up to 962 °C.
SB148/SB158	10 channel automatic/remote scanner. Expandable to 60 channels. IEEE-488 or RS232 compatible. Current source for unselected PRTs.
RW	Oil filled Standards Resistors. 1, 10, 25, 100 & 1000 ohms.
RTE	Thermal enclosure for RW & RR resistors.
TMS	PC compatible, graphical based Data Acquisition and Control Software.

Figure 8-1. Accessories

9. Service and Warranty

F18 equipment and accessories, (unless stated otherwise), are covered by a 12 month warranty for parts and labor, but not including costs incurred in returning it to the factory for repair, from the date of dispatch from Automatic Systems Laboratories.

9.1. Technical Support

For all technical support, repair, warranty and service inquiries please contact:

**Isotech North America
158 Brentwood Drive, Unit 4
Colchester, VT 05446**

**Phone: 802-863-8050
Fax: 802-863-8125**

**sales@isotechna.com
www.isotechna.com**

9.2. Returned Instruments

All returned goods should be sent carriage paid insured and packed well, to the above address.

9.3. Documentation

The shipment should include:

- I. Your goods return note, a delivery note or an export invoice that clearly GOODS RETURNED FOR REPAIR.
- II. Your Company / Establishment order or contract reference number.
- III. The name of your purchasing and technical contact.
- IV. A brief fault report.

9.4. Repair Quotations

We shall be pleased to advise estimated repair costs upon receipt and initial inspection of returned goods.

NOTES

NOTES

NOTES