



MK II

WORKING INSTRUCTIONS

AVO LTD.

AVOCET HOUSE, 92-96, VAUXHALL BRIDGE ROAD, LONDON, S.W.1
ENGLAND

**THE
MODEL 8 UNIVERSAL
AVOMETER
Mk II**

INSTRUCTIONS FOR USE



AVOCET
TRADE MARK

AVO LTD.

AVOCET HOUSE, 92-96 VAUXHALL BRIDGE ROAD, LONDON, S.W.1.

Telephone: VICToria 3404 (12 lines)

ENGLAND

Telegrams: Avocet, Sowest, London

A MEMBER OF THE METAL INDUSTRIES GROUP OF COMPANIES

FOREWORD

For more than a quarter of a century we have been engaged in the design and manufacture of "AVO" Electrical Measuring Instruments. Throughout that time we have consistently pioneered the design of modern multi-range instruments and have kept abreast of, and catered for, the requirements of the epoch-making developments in the fields of radio and electronics.

The success of our steadfast policy of maintaining high standards of performance in instruments of such wide versatility, and making such instruments available at reasonable cost, is reflected in the great respect and genuine goodwill which "AVO" products enjoy in every part of the world.

It has been gratifying to note the very large number of instances where the satisfaction obtained from the performance of one of our instruments has led to the automatic choice of other instruments from the "AVO" range. This process, having continued over a long period of years, has resulted in virtual standardisation on our products by numerous Public Bodies, The Services, Railway Systems, and Post Office and Telegraph Undertakings throughout the world.

Our designers have thereby been encouraged to ensure that new instruments or accessories for inclusion in the "AVO" range fit in with existing "AVO" apparatus and serve to extend the usefulness of instruments already in being. Thus, the user who standardises on "AVO" products will seldom find himself short of essential measuring equipment, for, by means of suitable accessories, his existing equipment can often be adapted to most unusual demands.

It is with pleasure that we acknowledge that the unique position attained by "AVO" is due in no small measure to the co-operation of so many users who stimulate our Research and Development staffs from time to time with suggestions, criticisms, and even requests for the production of entirely new instruments or accessories. It is our desire to encourage and preserve this relationship between those who use "AVO" instruments and those who are responsible for their design and manufacture, and correspondence is therefore welcomed, whilst suggestions will receive prompt and sympathetic consideration.



THE MODEL 8 AVOMETER MK. II

CONTENTS

	PAGE
FOREWARD	2
INTRODUCTION	5
TABLE OF RANGES	6
GENERAL DESCRIPTION	7
LIMITS OF ACCURACY	7
DESIGN AND CONSTRUCTION	8
RANGE CONTROLS	8
THE MOVEMENT	9
SCALING	9
REPLACEMENT OF INTERNAL BATTERY AND CELL	9
MOVEMENT REVERSE CONTROL	10
OVERLOAD PROTECTION	10
OPERATION OF INSTRUMENT	11
CURRENT MEASUREMENT	11
VOLTAGE MEASUREMENT	11
RESISTANCE MEASUREMENT	12
INSULATION RESISTANCE MEASUREMENT	13
LOW RESISTANCE MEASUREMENT	13
DECIBELS	13
ACCESSORIES	14
D.C. VOLTAGE MULTIPLIER	
RESISTANCE RANGE EXTENSION UNIT	
TRANSFORMERS	
CONCLUSION	15
CIRCUIT DIAGRAM OF THE MODEL 8 UNIVERSAL AVOMETER	16

COPYRIGHT

No information or diagrams in whole or in part may be copied or reproduced without the prior permission
in writing of Avo Limited



INTRODUCTION

Since its conception in 1923, the AvoMeter has maintained a distinct lead upon all its competitors, and can today quite rightly be termed the most popular instrument of its type in the world, for in no other instrument can one find such a unique combination of ranges and comprehensive automatic overload protection, in addition to a high degree of accuracy, reliability and simplicity of use.

Much time and thought is continually devoted by our design department to the improvement of our products and it is for the Electronic Radio and Television Engineer that this new instrument has been primarily produced. The Model 8 AvoMeter Mk. II has the high D.C. voltage sensitivity of the High Resistance AvoMeter Models 1 and 2, but in addition, provision is made for the measurement of A.C. current. A further useful feature which has been incorporated is a push button change-over switch which enables the direction of the current through the moving coil to be reversed, thus obviating the necessity of changing leads when working with D.C. voltages and currents which may be either positive or negative in respect to a basic test position. The excellent qualities of previous models including the "AVO" automatic cut-out have been retained, and we have great confidence that given a reasonable amount of care and attention, not forgetting the removal of exhausted batteries, this instrument will give lasting satisfaction.

The
Model 8 Universal Avometer
Mk II

WORKING INSTRUCTIONS

General Description

The meter is supplied complete with a pair of special rubber-covered leads which are intended for attachment to the Avometer by means of its non-loss terminals. The remote ends of the leads are fitted with spring clips, which may be interchanged with the "AVO" PRODCLIPS which are supplied with the instrument.

"AVO" Prodclips have been introduced to enable connections for test purposes to be made at what are normally inaccessible points on a chassis. Examination will show that they are completely insulated with the exception of the jaws at one end, which can be opened by compressing the stem into the body of the clip. Rigid connections to wiring can thus be made by this insulated device in complicated wiring systems where other types of larger clip could not be attached, or if fixed might cause short circuits.

All tests, except those on the 2,500V. ranges, make use of the pair of terminals at the base of the instrument.

The meter is extremely simple to use, range selection in general being accomplished by means of two switch knobs.

A clearly marked 5" scale has uniformly divided graduations to match 100 and 250 scale markings, and in addition there is an ohms scale and one for decibels. An anti-parallax mirror permits readings of the knife edge pointer to be made with great precision.

Limits of Accuracy

Generally speaking, the highest percentage accuracy on current and voltage ranges is obtainable at the upper end of the scale, but on resistance ranges it is better towards the centre of the scale. In the case of voltage measurements, which are more frequently taken than those of current, successive ranges have been closely chosen to obviate the need for taking readings on very small deflections.

The instrument will produce its highest accuracy when used face upwards, in which position it has been calibrated.

D.C. Voltage. 2% of indication between full-scale and half-scale deflection.

Below half-scale deflection, 1% of the full-scale value.

D.C. Current. 1% of full-scale value over effective range.

A.C. Current and Voltage. (25-2000 c/s.) 2.25% of full-scale value over effective range.

The definition of "effective range" set down in the British Standard Specification 89/1954 is as follows, when related to the AvoMeter:—

D.C.—from 0.1 of scale-range to full-scale value.

A.C.—from 0.25 of scale-range to full-scale value.

It will be noted that with the exception of the D.C. voltage ranges, the instrument meets the requirements laid down in Section 6 of the British Standard Specification 89/1954 for 5" (127mm.) scale-length Industrial Portable Instruments. In practice, the Model 8 is well within the above limits, due to the great care taken in the manufacture of its various components, and to the fine initial calibration.

Inasmuch as rectifier moving coil instruments give readings on "A.C." proportional to the mean and not the R.M.S. value of the wave form with which they are presented, they depend for their accuracy not only upon their initial calibration, but also upon the maintenance of a sinusoidal wave form. Since the form factor (R.M.S. value divided by mean value) of a sine wave is 1.11, this has been taken into account in calibrating the meter which does, therefore, indicate R.M.S. values on the assumption that the normal sine wave will be encountered. Generally speaking, considerable wave form distortion can occur without appreciably affecting the form factor and resulting accuracy of measurement, but the user should recognise the possibility of some error when using distorted wave forms, squarish wave shapes producing high readings, and peaky ones, low readings.

Design and Construction

The instrument consists of a moulded panel on the inside of which are mounted the whole of the switching apparatus, resistances, shunts, transformer, rectifier, etc., together with the movement. The panel fits into a robust moulded case, the joint being rendered completely dust proof, whilst a carrying strap is provided to facilitate portability. The main switching is accomplished automatically by means of two knobs which indicate on the engraved panel, the range in use. These switches are of generous and robust design, the contacts being arranged to "make" before "break" on adjacent ranges; a feature which provides a factor of safety in use.

When the instrument is set for operation on D.C., the moving coil is associated with a universal shunt and series multipliers, whilst on A.C., a full-wave rectifier and transformer are also introduced.

Range Controls

The left-hand knob provides all the D.C. current and voltage ranges (except 2,500V.) and the right-hand knob the A.C. ranges (except 2,500V.) and also the resistance ranges. These knobs are electrically interlocked so that D.C. readings can only be made after the right-hand switch has been set to D.C., and the left-hand switch to the range selected. A.C. readings call for the left-hand switch to be set for A.C. (it must not be left at RESISTANCE) and the right-hand switch at the range required. Resistance tests require the left-hand switch to be set to RESISTANCE and the right-hand one to the desired range.

If the switches are inadvertently left to actual ranges simultaneously, there is no circuit through the meter, and it is thereby safeguarded against accidental damage or misleading readings.

It is possible to determine whether a source is A.C. or D.C., since A.C. will not produce pointer indication when the meter is set for D.C. measurement. A small pointer indication, however, may result if D.C. current is passed through an A.C. range, but no harm can be done to the meter provided it is not at the same time grossly overloaded.

The main ranges are engraved on the panel around the switches, and arrow heads on the knobs indicate the actual range selected. In the case of voltage, successive ranges are built up on the ratios of 2 : 1, 2.5 : 1 and 4 : 1, but in the case of current, a wide coverage has been chosen instead and the 10 : 1 ratio in general is followed. The 2,500V. ranges A.C. and D.C. are available by means of the two special terminals so marked.

Extremely wide coverage in resistance has been achieved by having a fundamental range as marked on the scale, together with ranges of $\times 100$ and $\div 100$ to supplement it. Before carrying out resistance tests, the meter should be adjusted for the state of the batteries. It is merely necessary to join the leads together and adjust to zero in the following sequence: ohms $\times 1$; ohms $\div 100$, followed by ohms $\times 100$, using in each case the adjuster to match the range.

In addition, a 200-megohm range marked "INS" is available, using an external D.C. voltage source.

The Movement

The moving coil consists of an aluminium former wound with copper wire and supplemented with Constantan in order to reduce temperature error. It is pivoted on hardened and highly polished steel pivots between conical spring-loaded jewels, and swings in a gap energised by two powerfully magnetised and aged 'Alcomax' blocks associated with mild steel pole pieces. Two phosphor bronze hair springs are fitted for the purpose of conveying current to the moving coil, and to provide controlling torque. A knife edge type of pointer is fitted enabling very fine readings to be taken, whilst the whole movement is perfectly balanced and reasonably damped so that the pointer quickly comes to rest.

Scaling

The scale plate has three main sets of markings, each of approximately 5" length, the outermost being for resistance measurement and is marked 0-200,000 ohms. The second is for current and voltage (both A.C. and D.C.) and is marked 0-100, with divisions approximately $1\frac{1}{4}$ mm. apart. The third scale, calibrated 0-250, has 50 divisions, and is so used for current and voltage measurements. In addition, there is a decibel scale marked from -15 dB. to +15 dB., which can be used with any of the A.C. ranges.

Replacement of Internal Battery and Cell

Inside the cover, under the carrying strap is mounted a 15V. battery and a $1\frac{1}{2}$ V. cell. These batteries should be examined from time to time to ensure that the electrolyte is not leaking and damaging the instrument. This condition will generally occur only when the cells are nearly exhausted. If it is known that the meter is going to stand unused for several months, it is preferable that these batteries should be removed to prevent possible damage.

When replacing batteries, the $1\frac{1}{2}$ V. cell and the 15V. battery must be inserted with the poles to match the markings of polarity inside the battery box.

Replacements: 1.5V. cell, $1\frac{3}{8}$ " dia. $\times 2\frac{3}{8}$ ", such as Ever Ready (or overseas, Berec) U.2.
15V. battery, $1\frac{1}{2}$ " $\times \frac{5}{8}$ " $\times 1\frac{1}{2}$ ", such as Ever Ready B.121.

Movement Reverse Control

It sometimes happens that D.C. voltages may be required both positive and negative to a reference point, or the direction of flow may be reversed. In order to simplify the matter of lead alteration, a movement reverse press button (REV. M.C.) is provided. It should be noted that the polarity marked on the terminals is for normal use and does not apply when the button is pressed.

Overload Protection

Apart from the ability to do its job, one of the most attractive features of the instrument is the provision of an automatic cut-out which gives a very high degree of overload protection to the whole of the instrument. The incorporation of this device will be found to be of particular value when conducting experimental work, for it imparts to the user the feeling of mental ease and confidence. When conducting experimental work with conventional moving coil meters, these can be easily ruined by inadvertently applied overloads, whereas the AvoMeter is so well protected that it can withstand considerable mishandling.

If an overload is applied to the meter, the cut-out knob springs from its normal position in the panel, thus breaking the main circuit, and this knob has only to be depressed to render the instrument again ready for use. It is important to note that the cut-out should never be reset when the instrument is connected to an external circuit, whilst the fault which caused the overload should be rectified before the meter is reconnected.

The mechanism is brought into operation by the moving coil coming into contact with a trigger just beyond its full-scale position. There is, in addition, a second release at the zero end, so that the cut-out is tripped if the meter is overloaded in reverse.

Although the overload mechanism gives almost complete protection to the meter, it cannot be guaranteed to fulfil completely its function in the very worst cases of misuse, such as the mains being connected across the meter when set to a current range. It should be noted that mechanical shock to the instrument will sometimes trip the cut-out mechanism. The cut-out should be reset, using direct pressure and without twisting the button, the instrument lying face upwards.

WARNING

Special care must be taken when using the instrument to service television receivers or other apparatus employing condensers of large capacity, for the inclusion of such components in a circuit may mean that very heavy peak currents may flow when the apparatus is switched on. Such surges produce a peaky wave form, and although these peaks are of only a few milli-seconds duration, they may, never-the-less, puncture the instrument rectifier. It is impossible to guard against this cause of damage by means of any form of cut-out mechanism, but instruments manufactured since July 1954 have been fitted with a surge suppression rectifier (SAI) across the main rectifier, to give the maximum protection which can be devised.

OPERATION OF INSTRUMENT

The meter is intended for use horizontally. Should it happen by any chance that the pointer is not on zero, it may be so set by means of the screw head on the panel.

The leads fitted with prods or clips, as required, should be connected to the lower pair of meter terminals in all cases except when measuring voltages over 1,000V. (see next paragraph).

When measuring current or voltage, ensure that the instrument is set to match the type of source to be measured (either A.C. or D.C.) and then choose a suitable range before connecting up to the circuit under test. When in reasonable doubt, always switch to the highest range and work downwards, there being no necessity to disconnect the leads as the switch position is changed. *Do not, however, switch off by rotating either of the knobs to a blank position.* If the voltage should exceed 1,000V., the instrument should be set to measure 1,000V. as described above, but the negative lead should be transferred to the appropriate 2,500V. terminal.

The instrument is flash tested at 6,000V. A.C., but should the meter be used with accessories on circuits in excess of 2,500V., it should be kept at the low potential end of the circuit (near earth potential). If this procedure cannot be adopted other suitable safeguards must be applied.

CURRENT MEASUREMENT

To measure current, the instrument should be set to a suitable A.C. or D.C. range, and then connected in series with the apparatus to be tested.

Generally speaking, the power absorbed in the instrument is negligible, but in cases of low voltage heavy current circuits, the inclusion of a meter may reduce the current appreciably below the value which would otherwise prevail. The potential drop at the meter terminals is in the order of $\frac{1}{3}$ V. on all D.C. ranges, except the 50 microamp range which has a drop of 125 milli-volts. In the case of A.C., it is less than $\frac{1}{4}$ V. on all ranges.

Standard meter leads have a resistance of 0.02 ohms per pair.

In certain cases, care should be taken to ensure that the circuit is "dead" before breaking into it to make current measurements.

VOLTAGE MEASUREMENTS

When measuring voltage, it is necessary to set the appropriate range of "A.C." or "D.C." and connect the leads across the source of voltage to be measured. If the expected magnitude of the voltage is within the range of the meter, but its actual value is unknown, set the instrument to its highest range, connect up and if below 1,000V. rotate the appropriate selector switch, decreasing the ranges step by step, until the most suitable range has been selected. Great care must be exercised when making connections to a live circuit, and the procedure should be entirely avoided if possible.

On D.C. ranges, the meter consumes only 50 microamps at full scale deflection, this sensitivity corresponding to 20,000 ohms per volt. In the case of A.C. ranges from 100V. upwards, full scale deflection is obtained with a consumption of 1mA. (1,000 ohms per volt). The 25V., 10V., and 2.5V. A.C. ranges consume 4, 10 and

40mA. respectively at full scale deflection. The meter maintains a high degree of accuracy for audio frequency tests up to 10 kc/s on ranges up to 250V. A.C.

Whilst discussing the problem of measuring voltage, it would be well to draw attention to the fact that in certain circuits where the current is limited because of the presence of a resistance between the source and the point at which a measurement is to be made, it is possible for the actual voltage to be higher normally than when the meter is connected. All current consuming voltmeters, however sensitive, draw current to varying degrees from the circuit under test, thus causing a higher volts drop in the resistances mentioned, and thereby causing the voltage to fall at the point of measurement.

Owing to the high sensitivity of the Model 8 on its D.C. ranges, this effect is unlikely to be of importance except in a very few instances. A practical example of where it might be taken into account is in the measurement of EHT voltage on a television set or the tapping on a potential divider, where the resistances are so high as to be comparable with the resistance of the meter on the range in use. It is generally possible to use a meter on a higher range than absolutely necessary, and in such a case the higher meter resistance causes less disturbance than would otherwise be the case. At the same time adequate pointer deflection for reasonable accuracy should be attained.

When it is essential to obtain an accurate indication of the voltage developed across a high resistance it is sometimes preferable to insert the meter in series with it, and to measure the current flowing. The reading given upon the meter, in milliamps, multiplied by the value of the resistance in thousands of ohms, will give the developed voltage.

RESISTANCE MEASUREMENT

There are three self-contained ranges covering from 0.5 ohms to 20 megohms, and provision is also made for both upward and downward extension of these limits. The self-contained ranges make use of the usual series circuit, and successive ranges are on 100 : 1 ratio, which permits of very wide coverage with three ranges.

On resistance ranges, the meter must not merely start from its normal instrument zero, but must have, in addition, a resistance zero corresponding to the full scale deflection of the meter. Before carrying out tests for resistance a check and, if necessary, adjustment should be carried out to ensure that when the leads are joined together the meter actually indicates zero ohms, irrespective of the condition of the battery (within the limits of adjustment). The method of adjustment is described later.

Owing to the nature of the scale, it is not easy to define the accuracy, but it should be within 3% of the reading about centre scale, increasing up to about 10% of the indication around deflections corresponding to 10% and 90% of full scale deflection.

Resistance test should never be carried out on components which are already carrying current.

On three ranges which utilise the internal source of voltage, it should be remembered that a positive potential appears at the negative terminal of the instrument when set for resistance tests. This fact may be important because the resistance of some components varies according to the direction of the current through them, and readings, therefore, depend upon the direction in which the test voltage is applied, quite apart from its magnitude. Such cases include electrolytic condensers and rectifiers.

When measuring the leakage resistance of an electrolytic condenser, the negative lead from the meter should be connected to the positive terminal of the condenser, and the ohms $\times 100$ range employed.

Before making resistance tests the pointer should be adjusted to zero in the following sequence:—

1. Set left-hand switch at "RESISTANCE".
2. Join leads together.
3. On the Ω range, adjust to zero by means of the knob marked "ZERO Ω ".
4. On the " $\Omega \div 100$ " range, adjust to zero by means of the knob marked "ZERO $\Omega \div 100$ ".
5. On the " $\Omega \times 100$ " range, adjust to zero by means of the knob marked "ZERO $\Omega \times 100$ ".

To test a resistance, set the right-hand switch at the range required, the leads being connected across the unknown component.

Resistance is read directly on the " Ω " range, but indications should be divided or multiplied by 100 on the other two ranges.

If on joining the leads together it is impossible to obtain zero ohms setting, or if furthermore the pointer position will not remain constant, but falls steadily, the internal battery or cell concerned should be replaced. It is important that a discharged unit should not be left in the instrument, since the electrolyte might seep through and cause damage to the meter.

NOTE. It can so happen that a 15-volt battery may age in such a manner that although it indicates a potential of 15 volts, its internal resistance has increased so much that some loss of accuracy can occur on the high resistance range ($\Omega \times 100$). If the battery has been in use for some time, or if errors are suspected on the high resistance range, it is worth while removing the battery and checking its short circuit current on the 100mA. D.C. range. If the battery fails to give a reading greater than 5mA, it should be discarded.

INSULATION RESISTANCE MEASUREMENT

Two courses are open, the first merely calling for a battery or other source of D.C. voltage in the order of 130V. to 160V. The left-hand switch should be set at "RESISTANCE" with the right-hand switch at "INS" and the meter leads should be connected to the battery. The pointer should be brought to zero on the ohms scale by means of the adjuster marked "ZERO $\Omega \times 100$ ". To test, connect the unknown resistance in series with the meter and its value will be that shown on the ohms scale multiplied by 1,000. Resistances up to 200 megohms can, therefore, be read on this range.

The alternative method makes use of the "Model 8 Resistance Range Extension Unit," described later.

LOW RESISTANCE MEASUREMENT

The meter setting marked L.R. is for use with the Model 8 Resistance Range Extension Unit. The method of use is described in the section upon accessories.

DECIBELS

The decibel scale can be used with any of the A.C. current or voltage ranges. It has a logarithmic scale shape and is useful in so far that it gives a measurement closely related to the impression of aural intensity in sound reproduction apparatus. A difference of one decibel is about the minimum difference which can be appreciated when comparing two intensities. For convenience, the scale is marked in decibels

both positive and negative from a reference point. The difference in level between a negative value on the dB. scale and a positive one is the sum of the two, i.e. the difference between -5 dB. and $+6$ dB. is $5 + 6 = 11$ dB.

It will be appreciated that when changing from one current or voltage range to the next higher, the pointer indication will fall, although input is kept constant. For a current or voltage range ratio of $2\frac{1}{2} : 1$ this corresponds to a reduction of 8 in the indication on the dB. scale. It follows, therefore, that 8 should be added to the reading every time an increase of $2\frac{1}{2}$ times takes place on the range. In the same way, 12 should be added for an increase of 4 times on the range, or $8 + 12 = 20$ dB. for an increase of $2\frac{1}{2} \times 4 = 10$ times in the range ratio.

The following might serve as an example: Suppose that the meter is connected on the 25V. A.C. range across the primary of an output transformer and that a reading of $+9$ dB. is indicated (corresponding to 12.5V. on this range). If now the output increases to say 40 volts, necessitating a change to the 100V. A.C. range, the pointer will indicate $+7$ on the dB. scale.

The $4 : 1$ increase in the voltage range calls for an addition of 12 to the dB. indication, so that its true value represents $+19$ dB. The increase over the original reading is $19 - 9 = 10$ dB.

ACCESSORIES

D.C. Voltage Multipliers

10kV D.C. Multiplier

A 10kV. D.C. Multiplier has been developed mainly to enable tests to be carried out in television circuits. The multiplier should be connected in series with the meter on its 2,500V. D.C. range, in which state maximum consumption on measurement cannot exceed 50 microamps, and may be considerably less. It is recommended that the meter is kept as near earth potential as possible, and the multiplier used at the high potential end, e.g., when measuring an E.H.T. voltage where the negative line is earthy, the multiplier should be connected between the point of positive potential and the positive terminal of the meter, the negative lead being connected to the terminal marked 2,500V. D.C.—. We do not recommend, in such cases, connecting the multiplier to the 2,500V. D.C.— terminal and pressing the moving coil reverse button, notwithstanding the fact that the meter is at the earthy end of the circuit.

25kV D.C. Multiplier

A 25kV. D.C. Multiplier is available for use in series with the meter set to its 10V. D.C. range, readings being made direct in kV on the 0-25 scale. It is *most* important to ensure that the meter is kept in the earthy end of the circuit and the multiplier connected to either the positive or negative terminal whichever is at high potential. This method of connection to get forward pointer indication with the meter earthy is recommended as we do not think it desirable to use the moving coil reverse button when measuring high voltage.

In general we recommend that neither the meter, multiplier nor leads are handled whilst high voltage tests are in progress, and a special lead is provided with the multiplier for connection to the high potential point.

NOTE. The 2,500V D.C. range is not employed when using this multiplier.

Resistance Range Extension Unit

This device enables the meter to be used for both high and low resistance measurements. It is complete with batteries (except in some instances) and switching to facilitate tests. The device should be connected to the lower terminals on the meter.

For high resistance the meter is set to the " $\Omega \times 100$ " position, the Unit switch at the "SET" position and the unknown resistance should then be connected to the "High" terminals. Adjustment to full scale deflection should be performed by means of the "ZERO $\Omega \times 100$ " knob. The Unit switch should then be rotated to "TEST", and the reading on the ohms scale noted. Its value is that shown multiplied by 1,000 corresponding to a range of 200 megohms.

On the low range the Unit switch should be placed at "SET", the unknown resistance connected to the "Low" terminals and adjustment to full scale deflection carried out by means of the "ZERO Ω " knob. The Unit switch should then be moved to position marked "TEST" and the pointer deflection on a uniformly divided scale noted. Full scale deflection corresponds to $2\frac{1}{2}$ ohms.

In order to avoid discharging the batteries, immediately tests have been completed the test leads and resistance should be removed from the unit, its switch set to the "low set" position, and the unit disconnected from the meter.

Replacements: 1.5V. Cell— $1\frac{3}{8}$ " dia. $\times 2\frac{3}{8}$ ", such as Ever Ready (or overseas, Berec) U.2
Four 30V. batteries— $1\frac{1}{32}$ " $\times \frac{5}{8}$ " $\times 2\frac{9}{16}$ ", such as Ever Ready B.123.

Transformers

Transformers as used on the Model 7 AvoMeter are equally applicable for use with the Model 8, when set to 100mA. A.C. It is necessary to connect the meter up to the secondary of the transformer before current is passed through the primary, and care should be taken that the cut-out is in position. If this course is not followed, quite a considerable voltage will appear at the secondary terminals, if current passes through the primary. Transformers for 50 amp., 100 amp., 200 amp. and 400 amp. are available.

CONCLUSION

Due to the high operational standards maintained throughout our organisation, and the close limits within which we work, breakdowns are comparatively rare, and can often be traced to transit damage or careless handling, for which the Company cannot be held responsible. Should you at any time have to return your instrument to the Company for repair, pack it carefully and enclose a note informing our engineers of the faults which you have found.

E. & O. E.



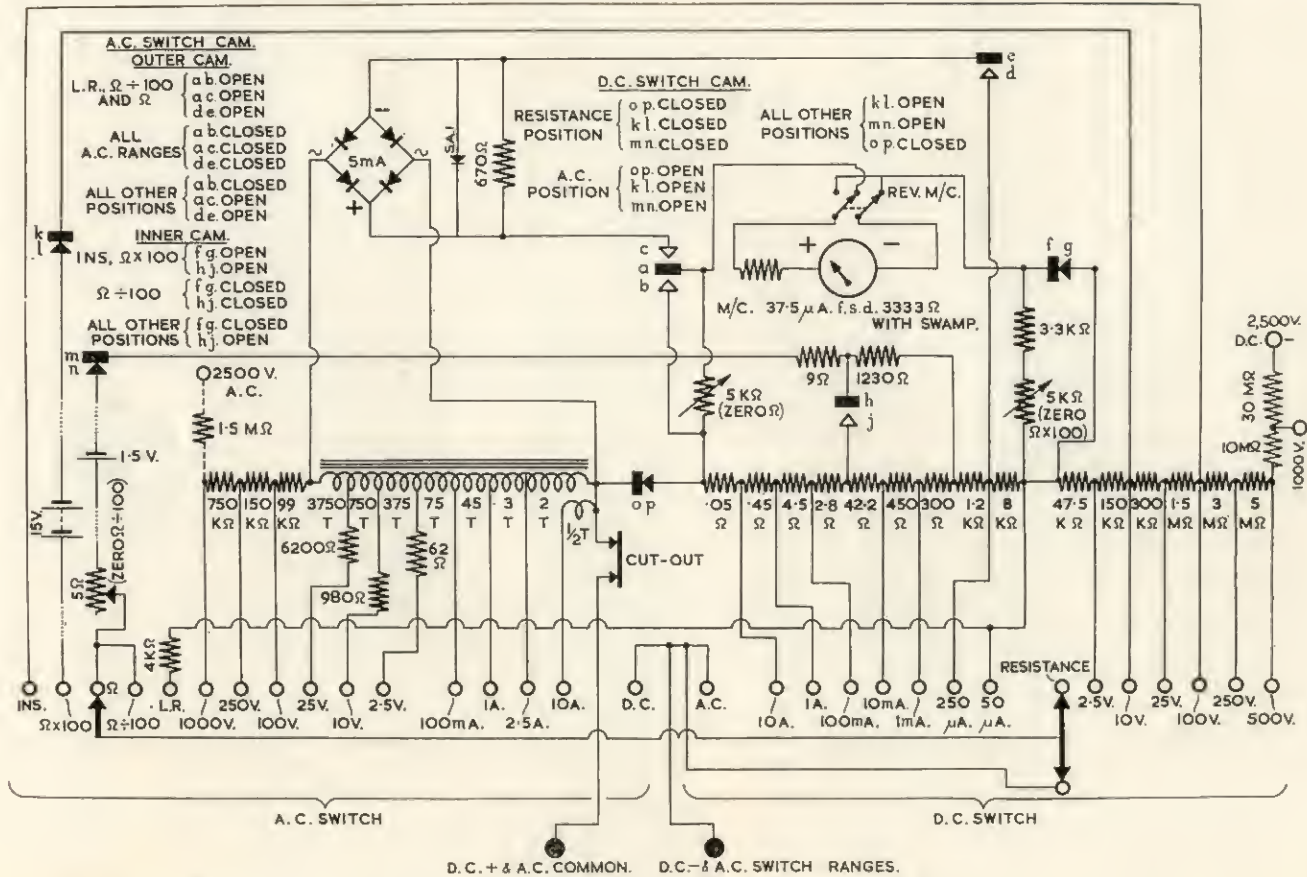

CIRCUIT DIAGRAM OF THE MODEL 8 AVOMETER

