ADVANTEST®

***R6161
Programmable Reference
DC Voltage/Current Generator
Operation Manual***

MANUAL NUMBER FOE-8311242C02

This product has been discontinued.
The Operation Manual is provided by
ADC Corporation under the agreement
with Advantest Corporation.

© 1991 **ADC CORPORATION**
All rights reserved.

First printing October 15, 1991
Printed in Japan

ADVANTEST is a trademark of Advantest Corporation. This product is developed, manufactured, and sold by ADC Corporation under the trademark license agreement with Advantest Corporation.

Safety Summary

To ensure thorough understanding of all functions and to ensure efficient use of this instrument, please read the manual carefully before using. Note that ADC Corporation (hereafter referred to as ADC) bears absolutely no responsibility for the result of operations caused due to incorrect or inappropriate use of this instrument.

If the equipment is used in a manner not specified by ADC, the protection provided by the equipment may be impaired.

- **Warning Labels**

Warning labels are applied to ADC products in locations where specific dangers exist. Pay careful attention to these labels during handling. Do not remove or tear these labels. If you have any questions regarding warning labels, please ask your nearest ADC dealer. Our address and phone number are listed at the end of this manual.

Symbols of those warning labels are shown below together with their meaning.

DANGER: Indicates an imminently hazardous situation which will result in death or serious personal injury.

WARNING: Indicates a potentially hazardous situation which will result in death or serious personal injury.

CAUTION: Indicates a potentially hazardous situation which will result in personal injury or a damage to property including the product.

- **Basic Precautions**

Please observe the following precautions to prevent fire, burn, electric shock, and personal injury.

- Use a power cable rated for the voltage in question. Be sure however to use a power cable conforming to safety standards of your nation when using a product overseas.
- When inserting the plug into the electrical outlet, first turn the power switch OFF and then insert the plug as far as it will go.
- When removing the plug from the electrical outlet, first turn the power switch OFF and then pull it out by gripping the plug. Do not pull on the power cable itself. Make sure your hands are dry at this time.
- Before turning on the power, be sure to check that the supply voltage matches the voltage requirements of the instrument.
- Connect the power cable to a power outlet that is connected to a protected ground terminal. Grounding will be defeated if you use an extension cord which does not include a protective conductor terminal.
- Be sure to use fuses rated for the voltage in question.
- Do not use this instrument with the case open.
- Do not place anything on the product and do not apply excessive pressure to the product. Also, do not place flower pots or other containers containing liquid such as chemicals near this

product.

- When the product has ventilation outlets, do not stick or drop metal or easily flammable objects into the ventilation outlets.
- When using the product on a cart, fix it with belts to avoid its drop.
- When connecting the product to peripheral equipment, turn the power off.

- **Caution Symbols Used Within this Manual**

Symbols indicating items requiring caution which are used in this manual are shown below together with their meaning.

DANGER: Indicates an item where there is a danger of serious personal injury (death or serious injury).

WARNING: Indicates an item relating to personal safety or health.

CAUTION: Indicates an item relating to possible damage to the product or instrument or relating to a restriction on operation.

- **Safety Marks on the Product**

The following safety marks can be found on ADC products.

 : ATTENTION - Refer to manual.

 : Protective ground (earth) terminal.

 : DANGER - High voltage.

 : CAUTION - Risk of electric shock.

- **Replacing Parts with Limited Life**

The following parts used in the instrument are main parts with limited life.

Replace the parts listed below before their expected lifespan has expired to maintain the performance and function of the instrument.

Note that the estimated lifespan for the parts listed below may be shortened by factors such as the environment where the instrument is stored or used, and how often the instrument is used.

The parts inside are not user-replaceable. For a part replacement, please contact the ADC sales office for servicing.

Each product may use parts with limited life.

For more information, refer to the section in this document where the parts with limited life are described.

Main Parts with Limited Life

Part name	Life
Unit power supply	5 years
Fan motor	5 years
Electrolytic capacitor	5 years
LCD display	6 years
LCD backlight	2.5 years
Floppy disk drive	5 years
Memory backup battery	5 years

- **Hard Disk Mounted Products**

The operational warnings are listed below.

- Do not move, shock and vibrate the product while the power is turned on. Reading or writing data in the hard disk unit is performed with the memory disk turning at a high speed. It is a very delicate process.
- Store and operate the products under the following environmental conditions.
 - An area with no sudden temperature changes.
 - An area away from shock or vibrations.
 - An area free from moisture, dirt, or dust.
 - An area away from magnets or an instrument which generates a magnetic field.
- Make back-ups of important data.
 - The data stored in the disk may become damaged if the product is mishandled. The hard disc has a limited life span which depends on the operational conditions. Note that there is no guarantee for any loss of data.

- **Precautions when Disposing of this Instrument**

When disposing of harmful substances, be sure dispose of them properly with abiding by the state-provided law.

Harmful substances: (1) PCB (polycarbon biphenyl)
 (2) Mercury
 (3) Ni-Cd (nickel cadmium)
 (4) Other

Items possessing cyan, organic phosphorous and hexadic chromium and items which may leak cadmium or arsenic (excluding lead in solder).

Example: fluorescent tubes, batteries

Environmental Conditions

This instrument should only be used in an area which satisfies the following conditions:

- An area free from corrosive gas
- An area away from direct sunlight
- A dust-free area
- An area free from vibrations
- Altitude of up to 2000 m

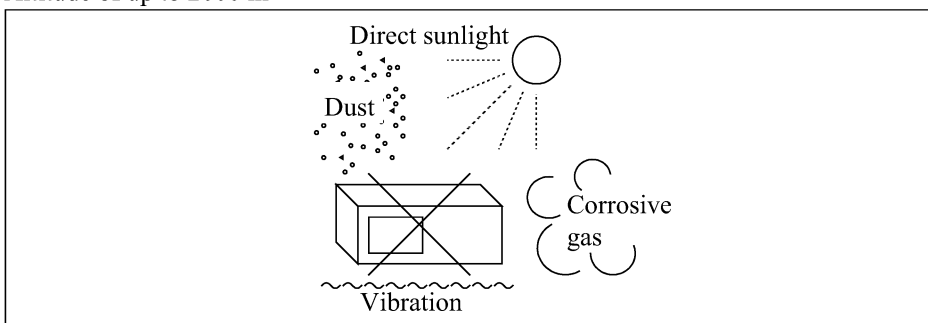

Figure-1 Environmental Conditions

- Operating position

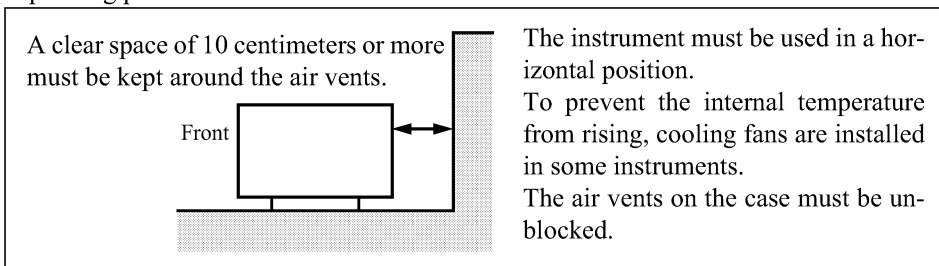

Figure-2 Operating Position

- Storage position

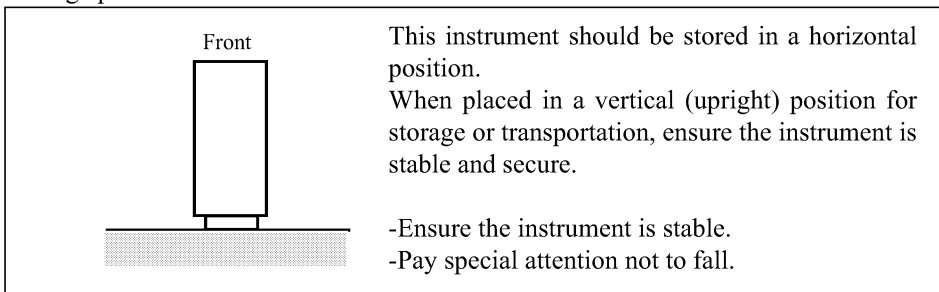

Figure-3 Storage Position



- The classification of the transient over-voltage, which exists typically in the main power supply, and the pollution degree is defined by IEC61010-1 and described below.

Impulse withstand voltage (over-voltage) category II defined by IEC60364-4-443

Pollution Degree 2

Types of Power Cable

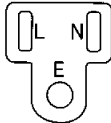
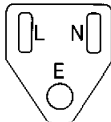
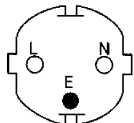
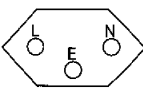
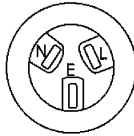
Replace any references to the power cable type, according to the following table, with the appropriate power cable type for your country.

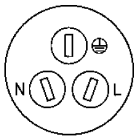
Plug configuration	Standards	Rating, color and length	Model number (Option number)
	PSE: Japan Electrical Appliance and Material Safety Law	125 V at 7 A Black 2 m (6 ft)	Straight: A01402 Angled: A01412
	UL: United States of America CSA: Canada	125 V at 7 A Black 2 m (6 ft)	Straight: A01403 (Option 95) Angled: A01413
	CEE: Europe DEMKO: Denmark NEMKO: Norway VDE: Germany KEMA: The Netherlands CEBEC: Belgium OVE: Austria FIMKO: Finland SEMKO: Sweden	250 V at 6 A Gray 2 m (6 ft)	Straight: A01404 (Option 96) Angled: A01414
	SEV: Switzerland	250 V at 6 A Gray 2 m (6 ft)	Straight: A01405 (Option 97) Angled: A01415
	SAA: Australia, New Zealand	250 V at 6 A Gray 2 m (6 ft)	Straight: A01406 (Option 98) Angled: -----
	BS: United Kingdom	250 V at 6 A Black 2 m (6 ft)	Straight: A01407 (Option 99) Angled: A01417
	CCC: China	250 V at 10 A Black 2 m (6 ft)	Straight: A114009 (Option 94) Angled: A114109

PREFACE

- This instruction manual describes the basic operations, system functions, measurement procedure, application notes, and maintenance guidance of your R6161 Programmable Reference DC Voltage/Current Generator (called the Generator in this manual). Read this manual first to use your R6161 safely and efficiently.
- If you are unfamiliar with the R6161 Generator, read Chapter 1 first.
- Manual configuration:
This manual consists of the following chapters and an appendix so that you can readily understand various R6161 Generator functions.

Chapter 1. Before Use
Chapter 2. Panel Layout
Chapter 3. Operations
Chapter 4. GPIB Connection and Interfacing
Chapter 5. BCD Remote Control and Input Signals
Chapter 6. Operation Principle
Chapter 7. Calibration
Chapter 8. Specifications
Appendix

**R6161 PROGRAMMABLE REFERENCE
DC VOLTAGE/CURRENT GENERATOR
INSTRUCTION MANUAL**

- Introduction to R6161 Generator:

The R6161 Programmable Reference DC Voltage/Current Generator (called the R6161 generator) uses the time-sharing technique in its reference voltage generator section.

The Generator can be set manually using the key switches. In addition, it can be set using the 100-channel memory data and from a distant location under remote control. The Generator has the continuous setup functions allowing fill-digit continuous changing, and it appears as your working standard of the best DC voltage/current generator.

- Generation voltage: 10 mV to 1199 V (10 mV to 1000 mV at divider output)
- Generation current: 1 mA to 119 mA
(Output Compliance: 130 V MAX.
1 mA/10 mA range with OPT.01: 1200 V MAX.)
- Voltage resolution: 1 μ V (1 V range, divider: 1000 mV range)
10 nV (divider: 10 mV range)
- Current resolution: 1 nA
- Built-in GPIB and BCD remote control
- Switch selectable GPIB operation modes: TR6120A mode (fully compatible with the TR6120A) and R6161 mode

TABLE OF CONTENTS

1. BEFORE USE	1-1
1.1 When You Receive Your R6161 Generator	1-1
1.1.1 Checking the Accessories	1-1
1.1.2 Option and Accessory List	1-1
1.1.3 Operation Conditions	1-2
1.1.4 Power Voltage	1-4
1.1.5 Power Cable	1-4
1.1.6 Replacing the Power Fuse	1-5
1.1.7 Setup of Power Voltage Card	1-6
1.2 List of Function	1-8
2. PANEL LAYOUT	2-1
2.1 Operation and Safety Markings	2-1
2.2 Front Panel	2-2
2.3 Rear Panel	2-14
3. OPERATIONS	3-1
3.1 Power ON and Startup Operations	3-1
3.1.1 Turning Power ON	3-1
3.1.2 Self-diagnosis and Revision and GPIB Address Indication	3-1
3.1.3 Initial Parameter Setup	3-3
3.2 Before Startup	3-4
3.2.1 Explanation of Basic Operations	3-4
3.2.2 Program Operation Flow	3-12
3.2.3 Connection to Loads	3-14
3.2.4 How to Use GUARD Terminal(for noise protection)	3-18
3.3 Standard Operations	3-21
3.3.1 Voltage Generation (during direct operation)	3-21
3.3.2 Current Generation (during direct operation)	3-23
3.3.3 Divide (DIV) Output Generation (during direct operation)	3-25
3.3.4 Zero Setup	3-27
3.3.5 Setting the Voltage/Current Limit	3-29
3.3.6 CONTINUOUS key Operaitons	3-33
3.3.7 Changing the Function Keys	3-35
3.3.8 Changing the Generation Range	3-37
3.3.9 Changing the Polarity	3-38
3.3.10 Restrictions on Limit Setup	3-39

3.3.11	Output Generation (1000V/100V range) and Current Limit Detection	3-40
3.4	Output Operation Timing	3-41
3.4.1	Timing when the Set Data is Changed	3-41
3.4.2	Timing when Output is Turned on (Operate) or Off (Standby)	3-41
3.4.3	Timing when the Range is Changed	3-42
3.3.4	Timing when the Function are Changed	3-43
3.4.5	Timing when the Polarity is Changed	3-44
3.4.6	Operate/Standby, Range, Function and Polarity Switching Time	3-45
3.5	Setup and Usage of Program Functions	3-48
3.5.1	Step Time	3-48
3.5.2	First/Last Channel	3-50
3.5.3	Memory Setup and Recall of Generation Data	3-53
3.5.4	Using the Step, Single Scan, and Repeat Scan Modes	3-59
3.5.5	Start/Pause/Home of Program Operation (in Recall mode)	3-62*
4.	GPIB CONNECTION AND INTERFACING	4-1
4.1	Outline of GPIB Interface	4-1
4.2	GPIB Performance and Specifications	4-3
4.2.1	GPIB Specifications	4-3
4.2.2	Interface Functions	4-4
4.3	GPIB Interface Application Notes	4-6
4.4	Device Address and Operation Mode (TR6120A or R6161) Setup	4-8
4.5	Listener Format	4-10
4.5.1	Program Codes (R6161 mode)	4-10
4.5.2	List of Program Codes (R6161 mode)	4-11
4.5.3	Parameter Store in Memory (R6161 mode)	4-14
4.5.4	Format of Direct Setup Program Codes for DC Voltage/Current Output (R6161 mode)	4-16
4.5.5	Program Codes (TR6120A mode)	4-17
4.5.6	List of Program Codes (TR6120A mode)	4-18
4.5.7	Format of Direct Setup Codes for DC Voltage/Current Output	4-19
4.6	Parameter Read Codes (Query)	4-20
4.6.1	Batch Read of Current Parameter Data	4-21
4.6.2	Data Read from Specified Memory	4-23
4.6.3	Data Read from Specified Memory Area	4-26
4.7	Service Request and Status Byte	4-27
4.7.1	Structure of Status Byte Register (R6161 mode)	4-28
4.7.2	Structure of Status Byte Register (TR6120A mode)	4-31
4.7.3	Service Request (SRQ)	4-32
4.8	Programming Examples	4-33
4.8.1	Programming Notes	4-33
4.8.2	Sample Programs (for HP200 Series)	4-35

5. BCD REMOTE CONTROL AND INPUT SIGNALS (EXTERNAL TRIGGER)	5-1
5.1 Outline of BCD Remote Control	5-1
5.2 Preparation and Notes on BCD Remote Control	5-2
5.3 Selection of BCD Remote Control	5-3
5.4 Interface Functions	5-4
5.5 Electrical Characteristics of Signals	5-6
5.6 External Trigger Input Signals	5-7*
6. OPERATION PRINCIPLE	6-1
6.1 Operations and Block Diagram	6-1
6.2 Data Setup Block	6-3
6.3 Reference Block	6-4
6.4 Amp Block	6-7*
7. CALIBRATION	7-1
7.1 Before Calibration	7-1
7.1.1 Instruments Required	7-1
7.1.2 Before Calibration	7-2
7.1.3 Calibration Notes	7-3
7.2 Calibration	7-4
7.2.1 Flowchart of Calibration Procedure	7-4
7.2.2 Calibration Procedure	7-5
8. SPECIFICATIONS	8-1
8.1 DC Voltage/Current Output Specifications	8-1
8.2 Voltage/Current Limiter	8-9
8.3 Program Functions	8-10
8.4 I/O Functions	8-11
8.5 System Specifications	8-12*
APPENDIX	A-1
A1.1 GPIB Remote Control Execution Time	A1-1
A1.1.1 Processing Method (for Model 16 of HP200 Series)	A1-1
A1.1.2 Program Code Execution Time (for Model 16 of HP200 Series)	A1-2
A1.2 BCD Remote Control Execution Time	A1-5
A1.2.1 Processing Method (for PC-9801) and Execution Time	A1-5
A1.3 Voltage Limit Error during Current Generation	A1-6
A1.4 OPR/STBY in 1000V Range or 1mA/10mA Range (Option 01)	A1-7

R6161 PROGRAMMABLE REFERENCE
DC VOLTAGE/CURRENT GENERATOR
INSTRUCTION MANUAL

Table of Contents

A1.5 Error List	A1-8
A1.5.1 List of Panel Setup Error Messages	A1-8
A1.5.2 GPIB Error Code List	A1-9
A1.5.3 List of BCD Remote Control Error Codes	A1-10
A1.5.4 Error Message List During Self-diagnostic Test and Actions Taken	A1-11*
 EXTERNAL VIEW	
R6161 EXTERNAL VIEW	EXT1
R6161 FRONT VIEW	EXT2
R6161 REAR VIEW	EXT3

LIST OF ILLUSTRATIONS

No.	Title	Page
1-1	Ambient Conditions	1-2
1-2	Generator Power Voltage Indicated at the Rear Panel	1-4
1-3	Plug and Adapter of Power Cable	1-5
1-4	Replacing the Power Fuse	1-6
1-5	Changing the Power Voltage	1-7
2-1	100VAC Model (Example)	2-14
2-2	Explanation of the Front Panel	2-16*
2-3	Explanation of the Rear Panel	2-16*
3-1	Basic Operation Flow	3-4
3-2	Program Operation Flow	3-12
3-3	Equivalent Circuit	3-16
3-4	How to Use GUARD Terminal (for 2-wire line)	3-19
3-5	How to Use GUARD Terminal (for 4-wire line)	3-20
3-6	Generator Front Panel	3-60
4-1	GPIB System Outline	4-2
4-2	Termination of Signal Lines	4-3
4-3	Pin Assignment of GPIB Interface Connector	4-5
4-4	Display during LOCAL and CONTINUOUS key Setup	4-8
4-5	Relationship between Status Byte and Mask Register (SMS)	4-27
4-6	Timing of Limit Bit (R6161 mode)	4-29
4-7	Timing of Syntax Error Bit (R6161 mode)	4-29
4-8	Timing of Program End (R6161 mode)	4-30
4-9	Timing of Limit Bit (TR6120A mode)	4-32
5-1	Electrical Characteristics of Signals	5-6
6-1	Block Diagram	6-2
6-2	Resistance Divider	6-4
6-3	Voltage Dividing by Time Division	6-4
6-4	Voltage Waveforms at Point (A)	6-5
6-5	Data Setup Block and its Waveforms	6-6
6-6	Voltage Generator Circuit	6-7*
6-7	Current Generator Circuit	6-7*
7-1	Flowchart of Calibration Procedure	7-4
A-1	Voltage Limit Detection Method During Current Generation	A1-6

LIST OF TABLES

No.	Title	Page
1-1	System Accessories	1-1
1-2	Option and Accessory List	1-1
1-3	Standards of Fuse	1-6
1-4	Changing the Power Voltage	1-7
3-1	Initial Setup Status (Standard Parameter Setup during Delivery)	3-3
3-2	Appropriate Setup Range and V/I Limit Range	3-10
3-3	Error due to Cable Resistance of 4-Wire Line	3-17
3-4	Resistance in Each Cable Unit Meter	3-17
3-5	Voltage/current Limit Defaults of Each Range	3-31
3-6	Limit Setting Range	3-31
3-7	Signal Generation Range	3-37
3-8	Time Required for Output Generation when Standby Status is Changed to Operate Status	3-45
3-9	Output Generation Time when the Range is Changed	3-45
3-10	Output Generation Time when Function is Changed	3-46
3-11	Output Generation Time during Polarity Change	3-47
3-12	Start/Pause/Home Control Modes	3-63*
4-1	Interface Functions	4-4
4-2	Generator Status Change by Command Input	4-7
4-3	List of Program Codes in R6161 Mode	4-11
4-4	List of Program Codes in TR6120A Mode	4-18
4-5	Parameter Read Codes	4-20
5-1	Remote Control Connector Functions	5-4
7-1	Instruments Required for Calibration	7-1

1. BEFORE USE

1.1 When You Receive Your R6161 Generator

1.1.1 Checking the Accessories

Table 1-1 System Accessories

Accessory name	Standards		Quantity	Remarks
	Model	Stock No.		
Power cable	A01402	DCB-DD2428X01	1	
Power fuse	1A slow blow fuse (313001)	DFT-AG1A	1	For 100/115/120 VAC model
	0.5A slow blow fuse (313.500)	DFT-AGR5A		For 220/230/240 VAC model
Instruction manual	—	ER6161	1	English manual

1.1.2 Option and Accessory List

Table 1-2 Option and Accessory List

Option/accessory	Explanation
Option 01	Can convert the output compliance of the 1 mA or 10 mA range into 1200 V.
A02708	Rack mount kit A (EIA standards; with front handles)
A02709	Rack mount kit A (JIS standards; with front handles)
A02718	Rack mount kit B (EIA standards; without front handles)
A02719	Rack mount kit B (JIS standards; without front handles)

Notes: Use the slide rail set or angles to mount the Generator on the system rack. This is because the rack mount kit is not rigid enough to supporting the Generator. Consult our agency for rack setup and other technical support.

We recommend you to use a slide rail set A02615(option).

1.1.3 Operating Conditions

(1) Ambient conditions

- Avoid using the Generator in excessive dusts, vibration, direct sunlight, and corrosive gases.
- Use the Generator in the ambient temperature of 0 to +40°C and relative humidity of 70% or less.
- To prevent an overheat, keep the rear panel of the Generator away from a wall. Do not install the Generator in the vertical layout, or do not cover the ventilation slits at the bottom of the Generator.
Also, take care to have a natural air flow. Keep the Generator at least 10 cm away from a wall or others.
- Use your Generator in the minimum noise environment. If it exist, use a noise filter or others.

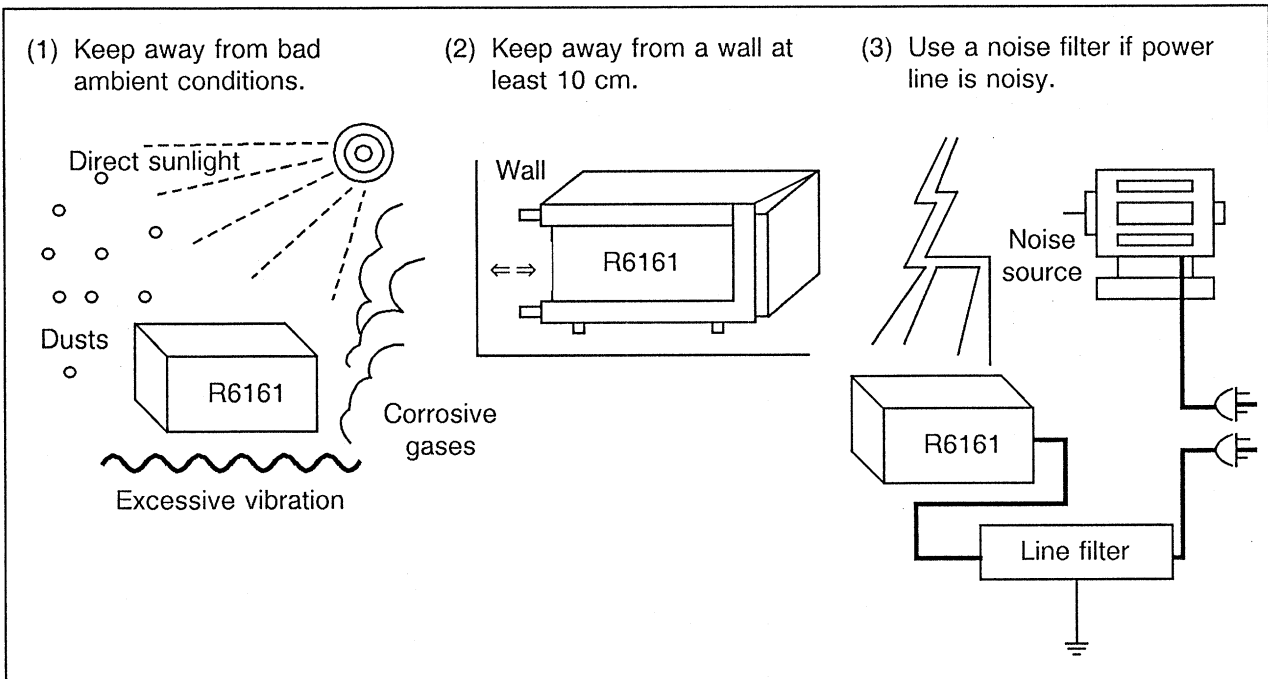

Figure 1-1 Ambient Conditions

**R6161 PROGRAMMABLE REFERENCE
DC VOLTAGE/CURRENT GENERATOR
INSTRUCTION MANUAL**

1.1 When You Receive Your R6161 Generator

(2) Warm-up (preheating time)

The Generator must be warmed up if:

- It is moved from the normal temperature (+ 18 to + 28°C) to the calibration room.
Place the Generator in the room for two hours, and preheat it for one or more hours.
- It is moved from the low temperature (+ 18°C or less) to the calibration room.
Place the Generator in the room for two hours, and preheat it for two or more hours.

CAUTION

The water condensing may occur due to increased humidity. Dry the Generator well, and start its calibration.

- It is moved from the high temperature (+ 28°C or more) to the calibration room.
Place the Generator in the room for two hours, and preheat it for two or more hours.

(3) Cleaning

Clean the Generator using a silicon cloth or soft cloth when necessary.

CAUTION

Do not use an organic solvent (such as benzine and acetone) which can cause a damage on the plastic material.

(4) Storage

- If you do not use your Generator for a long time, cover it with a clean polyethylene bag or place it in the fiberboard container, and keep it in the dark and dry storage area.
- The recommended storage temperature range is – 25 to + 70°C.

(5) Transportation

Pack the Generator using the its container and packing materials. If you have lost the container, use the following procedure.

- ① Wrap the Generator with clean polyethylene sheets.
- ② Use a 5-mm thick fiberboard container and an appropriate packing material.
- ③ Pack the Generator with the packing (buffer) material, place all accessories, and bundle the container using the rigid strings for handling.

R6161 PROGRAMMABLE REFERENCE
DC VOLTAGE/CURRENT GENERATOR
INSTRUCTION MANUAL

1.1 When You Receive Your R6161 Generator

1.1.4 Power Voltage

The standard power voltage of your Generator is printed on the nameplate at the rear panel (Figure 1-2). Make sure that your local voltage matches this voltage.

CAUTION

Turn the Generator power switch OFF, and plug the power cable into the power receptacle.

The power frequency must be 50 Hz or 60 Hz.

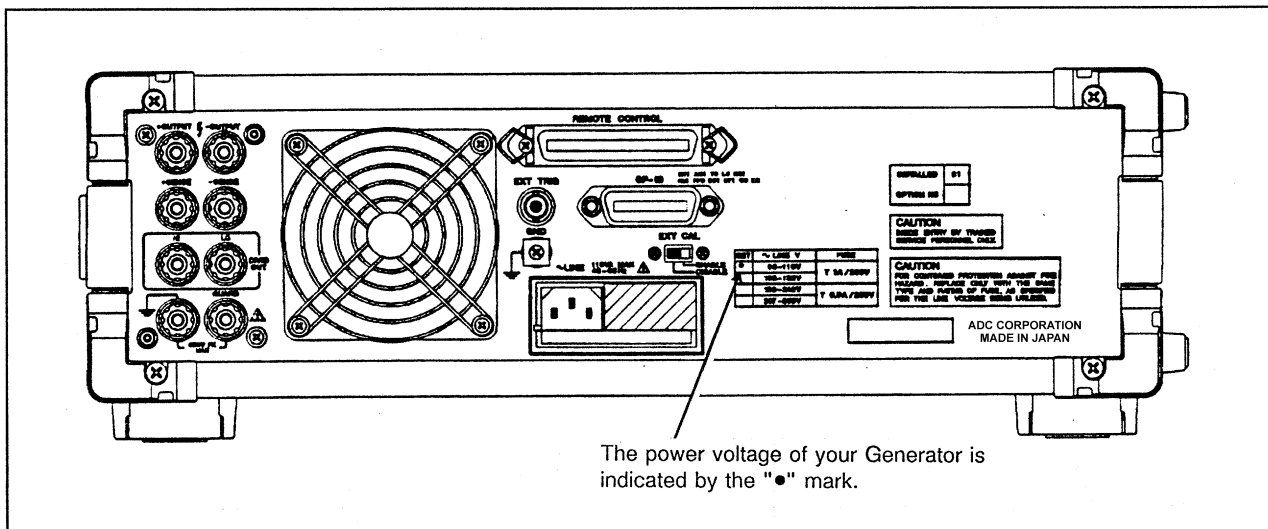

The power voltage of your Generator is indicated by the "•" mark.

Figure 1-2 Generator Power Voltage Indicated at the Rear Panel

1.1.5 Power Cable

The power cable has three pins. The round pin is ground (Figure 1-3 (1)).

Plug the power cable into a receptacle having the ground terminal. If it does not have the ground terminal, use the A09034 Adapter of the accessory kit. In such case, you must securely ground either the ground lead of the power cable plug or the GND terminal of the Generator rear panel to the building ground.

The A09034 Adapter has two electrodes whose width differ from each other (Figure 1-3 (2)). Check the correct polarity of the plug and receptacle.

If the A09034 Adapter does not match your receptacle, use the KPR-13 Adapter (optional).

CAUTION

Never contact the ground lead of the adapter to the AC power line, or the Generator or other attached devices will be damaged.

Table 1-3 Standards of Fuse

Specifications	Standards	
	Model	Stock No.
100/115/120 VAC power source	1 A slow blow fuse (313001)	DFT-AG1A
220/230/240 VAC power source	0.5 A slow blow fuse (313.500)	DFT-AGR5A

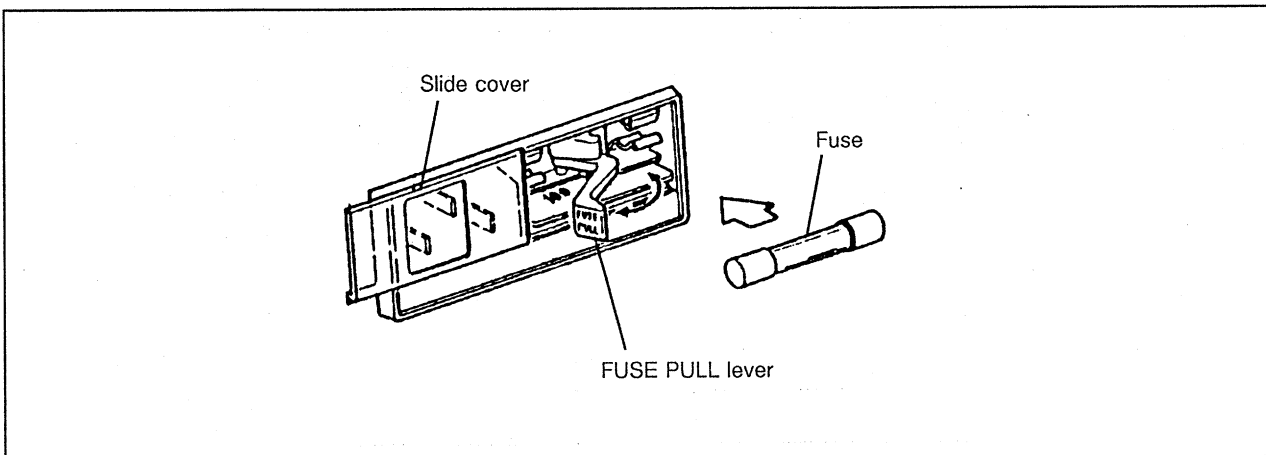

Figure 1-4 Replacing the Power Fuse

1.1.7 Setup of Power Voltage Card

The power voltage card is mounted on the power connector of the rear panel as shown in Figure 1-5.

Power voltage changing procedure:

- ① Unplug the power cable from the power connector.
- ② Slide the cover to the left.
- ③ Pull and rotate the FUSE PULL lever to the left, and the fuse will be removed.
- ④ Pull out and remove the card using a radio-plier.
- ⑤ Face the correct power voltage marking position of the card and insert it into slot (See Table 1-4).
- ⑥ Mount the fuse, and push back the FUSE PULL lever.
- ⑦ Close the slide cover.

**R6161 PROGRAMMABLE REFERENCE
DC VOLTAGE/CURRENT GENERATOR
INSTRUCTION MANUAL**

1.1 When You Receive Your R6161 Generator

Table 1-4 Changing the Power Voltage

Desired power voltage (VAC)	100 V	120 V	220 V	240 V
Voltage range (V)	90 to 110 V	103 to 132 V	198 to 242 V	207 to 250 V
Fuse capacity (A)	1 A		0.5 A	
Card setup	100	120	220	240
Voltage switch	100 V/120 V		220 V/240 V	

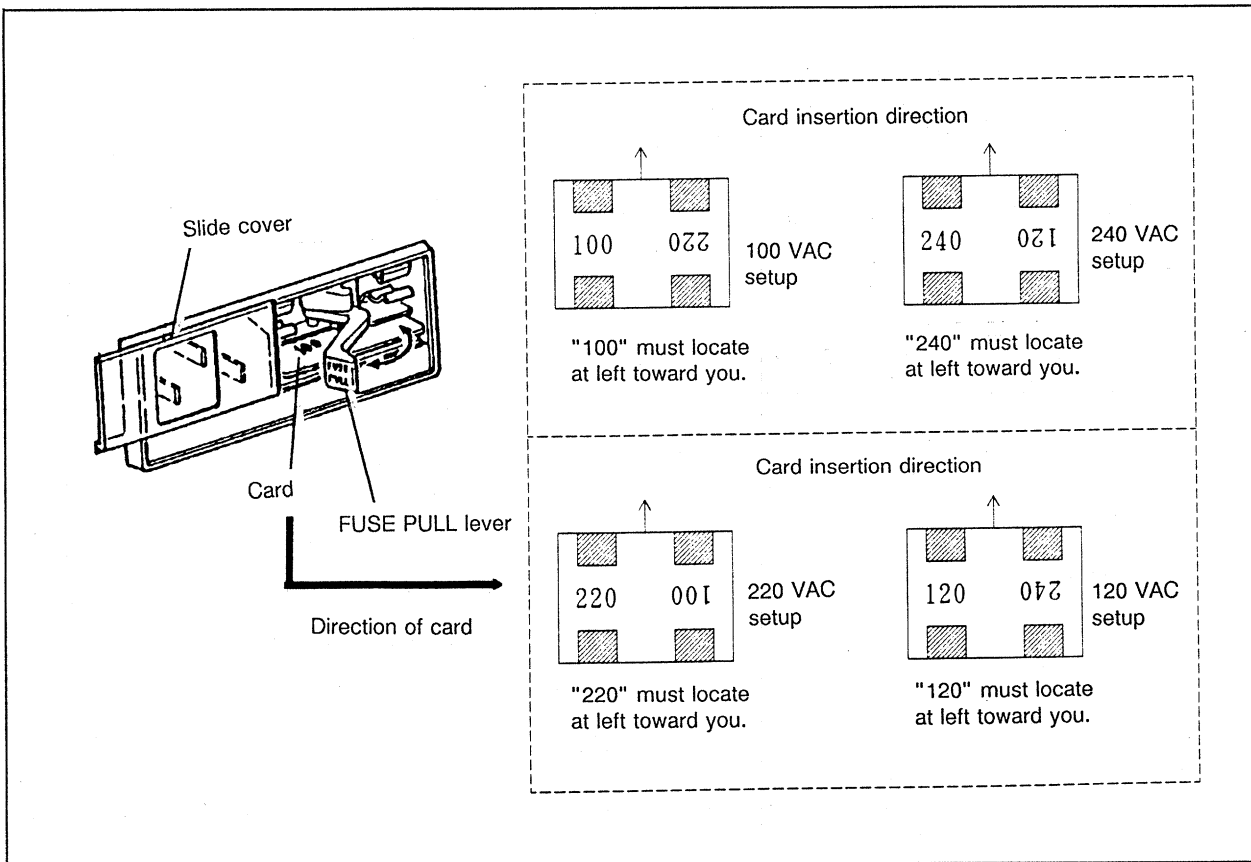

Figure 1-5 Changing the Power Voltage

1.2 List of Functions



Function	Explanation
(1) Data store in system memory	<p>● Memory function The Generator has the built-in memory consisting of 100 channels of data store area (channels 00 to 99). Each channel can store the generation data (V, I, and V-DIVID data) and V or I limit data.</p> <div style="border: 1px solid black; padding: 5px; text-align: center;"> <p>CAUTION</p> <p>No voltage or current can be output in memory mode (when the MEMORY lamp is on).</p> </div>
(2) Data call from system memory	<p>● Recall function Recalls data from the system memory in one of the following four modes:</p> <ul style="list-style-type: none"> - Random channel access (See Paragraph (3).) - Step scan (See Paragraph (4).) - Single scan (See Paragraph (5).) - Repeat scan (See Paragraph (6).) <div style="border: 1px solid black; padding: 5px; text-align: center;"> <p>CAUTION</p> <p>If you press a key in the operation status, its recall data is output. Check the OPERATE key status and execute the job.</p> </div>
(3) Data store in system memory and recall of <u>any program channel data</u>	<p>● Random channel access function Recalls any program channel data.</p> <p>Example:</p> <div style="display: flex; align-items: center; margin-bottom: 10px;"> <div style="text-align: center;"> <p>RECALL</p> <div style="border: 1px solid black; width: 60px; height: 20px; margin: 0 auto;"></div> <p>(CHANNEL)</p> </div> <div style="margin: 0 10px;">:</div> <div> <p>The RECALL lamp is on (RECALL mode).</p> </div> </div> <div style="text-align: center; margin-bottom: 10px;"> <p>↓</p> </div> <div style="display: flex; align-items: center;"> <div style="display: flex; gap: 5px;"> <div style="border: 1px solid black; width: 20px; height: 20px; text-align: center; line-height: 20px;">6</div> <div style="border: 1px solid black; width: 20px; height: 20px; text-align: center; line-height: 20px;">1</div> <div style="border: 1px solid black; width: 60px; height: 20px; margin-left: 5px;"></div> </div> <div style="margin: 0 10px;">:</div> <div> <p>Data of channel 61 is displayed in 10⁰ to 10⁶ digits.</p> </div> </div> <p>(CHANNEL)</p> <p>* You can recall any channel data of channels 0 to 99. * When the OPERATE key is on, you can output the recall data.</p>
(4) Sequential <u>data call from first to last channels</u>	<p>● Step scan function Data can be recall sequentially from the first to last channels of memory. To do so, use the START key or use the "EXT.TRIG" terminal at the rear panel.</p>

Function	Explanation
(5) <u>Sequential single-time data call from first to last channels at the step time interval</u>	<p>● Single scan function Data can be recall sequentially only once from the first to last channels of memory at the interval (1 to 99 seconds) set by the Step Time option.</p>
(6) <u>Repeated and continuous data call from first to last channels at the step time interval</u>	<p>● Repeat scan function Data can be recall repeatedly and continuously from the first to last channels of memory at the interval (1 to 99 seconds) set by the Step Time option.</p>
(7) Data output setup using Data control knob	<p>● Continuous output function Data output can be set from any position of 10^0 to 10^6 digits to the full-scale position by using Data Control knob.</p> <div style="border: 1px solid black; padding: 5px; text-align: center;"> <p>CAUTION</p> <p>The Memory mode is not supported by this function.</p> </div>
(8) Load protection by limitation of load voltage and load current	<p>● V and I limit function The limiter can protect the load by limiting the load voltage and load current. The V and I limit function of the Generator allows you to limit both the load voltage and current during output voltage and current generation. If you have set the maximum allowable voltage (V limit value) in the voltage generation mode, you can prevent an overvoltage generation due to a malfunction. Similarly, you can prevent an overcurrent (by setting the I limit value) in the current generation mode.</p> <div style="border: 1px solid black; padding: 5px; text-align: center;"> <p>CAUTION</p> <p>If the voltage or current limit has reached in the 1000 V range, or 1 or 10 mA range of option 01 (with the 1200 V output compliance for 1 or 10 mA), the Generator is reset to the Output OFF (Standby) status.</p> </div>

2. PANEL LAYOUT

2.1 Operation and Safety Markings

The following operation and safety markings are printed on the Generator front and rear panels.

Marking	Explanation
	Printed on the output terminal block. You must refer to the Instruction Manual. (This marking shows the warning in handling or precaution that you must follow.)
	The terminal is connected to the internal high voltage exceeding 1000 V. The lamp of this marking lights when either the 1000 V range or 1 mA or 10 mA range of option 01 is selected.
	Ground terminal. You must ground this terminal.
~ LINE	Receptacle of AC source voltage line

2.2 Front Panel

(See Figure 2-2 for switch and lamp layout on the Generator front panel.)

- ① POWER switch
Turn the Generator power supply on or off each time this button is pressed.
When the POWER switch is pushed down, the internal circuits of the Generator are powered and the Generator starts operating.
When it is pushed up, the Generator power supply is turned off. (See Section 3.1.1 for indication during power on.)
- ② Display section
Displays the output setup data, program data [channel, data, first/last/channel/sec unit, step time, and scan sequence (step, single or repeat)], and V/I limit data.
 - Ⓐ Data setup display: Right-hand side, 7-digit, 7-segment LED
 - Ⓑ Channel setup display: Left-hand side, 2-digit, 7-segment LED
(Step time)
 - Ⓒ First/last/channel/sec unit: Each selected unit is indicated by the LED.
 - CH: Channel in abbreviated form
 - SEC: Seconds in abbreviated form
 - DIV: Divider in abbreviated form
- ③ CONTINUOUS keys and DATA CONTROL KNOB
Use these keys for continuous output generation. The CONTINUOUS keys cover 10^0 to 10^6 digits. When you press any digit key, (its display value flashes and) you can set a value from zero to full-scale value beginning from this digit.

CAUTION

If the Auto Range mode has been selected, an appropriate range is selected automatically. Therefore, the CONTINUOUS flash position also moves (to keep the fixed setup resolution).

- ④ DIVIDER key
Use the DIVIDER key to set the V, I, or DIV function to "DIV" (Divider). The Divider Output terminal ⑩ is separated from the V/I output terminal.
When you set the Divider function, the unit (mV) and DIV LEDs light in the unit display section.

CAUTION

1. You can specify direct change to the divider range of 10 mV, 100 mV or 1000 mV only from the 1 V range of V generation (function). (The divider range via the GPIB interface is accepted at V2, V3, or V9.)
2. This key functions as the "mV" unit (having the same meaning as "V" and "mA") in the memory operation.
3. The output is turned "OFF" (the Operate lamp goes out) during divider change.

⑤ **LIMIT keys**

Use the LIMIT keys to set the voltage or current limit or check them.

Checkout method:

- Press the V or I key, and the limit lamp will light and data will be displayed in the data setup section. When you press the key again, the limit lamp will go out and the previous data is redisplayed.

Examples:

V limit display

UL.1250 V

I limit display

IL.125 mA

V/I limit setup range and resolution:

	Setup range	Resolution
V limit	10 V to 1250 V	10 V
I limit	1 mA to 125 mA	1 mA

⑥ GPIB status lamps

When the Generator is remotely controlled via the GPIB interface, the device status is indicated by the status lamps.

SRQ lamp: Lights when a service request is issued to the controller.

TALK lamp: Lights when the Generator is in the talker status to send data.

LISTEN lamp: Lights when the Generator is in the listener status to receive data.

REMOTE lamp: Lights when the Generator is remotely controlled by a peripheral equipment. When this lamp is on, you can use LOCAL key ⑦ only.

⑦ LOCAL key

- If you press the LOCAL key when the Generator is controlled via the GPIB interface (the REMOTE lamp is on), the external control status is released. You can use any key on the front panel.
- In the Local status, you can select the GPIB address, turn the header on or off, select the TR6120A or R6161 operation mode for the GPIB interface (See Section 4.4), and select the BCD remote control mode (See Section 5.3).

CAUTION

If the "LLO" (Local Lock Out) command has been received via the GPIB interface, you cannot release the remote mode using this LOCAL key. In such case, send the "GTL" (Go To Local) command to release the LLO status.

⑧ HIGH V lamp

Lights when the 1000 V range, or 1 mA or 10 mA range of option 01 (with the 1200 V output compliance) is selected.

CAUTION

When the Generator is changed to the 1000 V, or 1 mA or 10 mA range of option 01, generator output status is set to Output OFF (Standby).

- ⑨ OUTPUT terminals
Use the "+ OUTPUT" and "- OUTPUT" terminals for positive and negative voltage output.
Use the "+ SENSE" and "- SENSE" terminals for feedback signal input.
Use the OUTPUT terminal to connect to the load via two lines.
If the voltage drop of cable cannot be ignored, turn "EXT SENSE" key ⑮ ON (4-wire) and connect the \pm OUTPUT and \pm SENSE terminals separately at the load side.
(See Section 3.2.3 for connection to loads.)

- ⑩ DIVID OUT (Divider Output) terminals
Use them for 10 mV, 100 mV, and 1000 mV range output terminals (HI and LO) of the divider function.

CAUTION

The divider output resistance is approximately 200 Ω . Consider it when the load current flows.

- ⑪ GUARD terminal
Use the GUARD terminal to remove the noise occurring between the housing (or GND terminal if grounded) and the load. (See Section 3.2.4.)
- ⑫ GROUND terminal
Connected to the housing (or GND terminal if the Generator is grounded).

Use this terminal to:

- Connect the Generator output to the housing potential (for jumpering between the - OUTPUT and GND terminals).
- Suppress the RF noise affection (for short connection via the jumper line or capacitor between - OUTPUT and GND terminals).
- Set the potential around the load to the same as the housing potential.

< Voltage Display Descriptions >

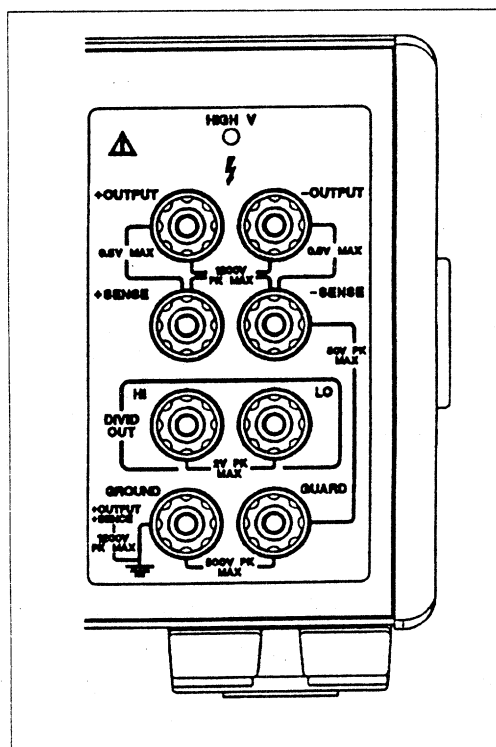

Output Terminals on Front Panel

(* The output terminals on the rear panel are the same as those of the front panel.)

The relationships between the output voltages and terminals are as follows.

- Between + OUTPUT/+ SENSE and – OUTPUT/– SENSE
1200 V peak: Maximum output voltage
- Between + OUTPUT and + SENSE
Between – OUTPUT and – SENSE
0.5 V peak: Maximum applied voltage
- Between HI and LO of DIVID OUT
2 V peak: Maximum applied voltage
- Between – OUTPUT/– SENSE and GUARD
50 V peak: Maximum applied voltage
- Between GUARD and GROUND
500 V peak: Maximum applied voltage
- Between + OUTPUT/+ SENSE and GROUND
1200 V peak: Maximum applied voltage

CAUTION

The display between + OUTPUT/+ SENSE and -OUTPUT/-SENSE is the maximum output voltage. The maximum applied voltages from the outside are as follows.

Do not apply voltage which exceeds the following ranges.

- For positive polarity (+): -0.5 to $+V_0$ [V peak]
- For negative polarity (-): $+0.5$ to $-V_0$ [V peak]

(For V_0 , use either the set voltage generator value or the voltage limit value, whichever is smaller.)

⑬ OPERATE key and lamp

Turns the output on or off as follows.

OPERATE
 (lamp is off): Turns the output off.

OPERATE
 (lamp is on): Turns the output on.

(See Section 3.4.2.)

CAUTION

If the limiter is started in the 1000 V range, or 1 mA or 10 mA range of option 01 (with 1200 V output compliance), the operation mode is forcibly set to Output OFF.

⑭ EXTERNAL GUARD key and lamp

Connects the GUARD terminal to the – OUTPUT terminal internal line of the Generator or the external – OUTPUT line (output cable).

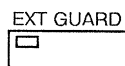

(lamp is off): Connects the GUARD terminal to the internal – OUTPUT terminal line. (Normal operation mode)

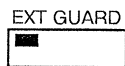

(lamp is on): Connects to the external – OUTPUT line.
(Use this mode to suppress the noise in common mode.)
(See Section 3.2.4.)

⑮ EXTERNAL SENSE key and lamp

Switches the output terminal connection between the two-wire and four-wire lines.

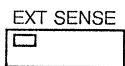

(lamp is off): Connects to the two-wire line.
(Use this mode if there is almost no load.) *

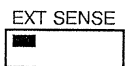

(lamp is on): Connects to the four-wire line.
(Use this mode if the load current flows.)
(See Section 3.2.3.)

- * The output resistance of the two-wire line is approximately 100 m Ω .
Therefore, use a 100 k Ω or larger load to suppress the error within 1 ppm due to the load during full-scale output.

CAUTION

You can turn on or off the EXT SENSE key independent from the V, I or DIVIDER function setup. However, in the Divider Output mode or Current Output mode, the two-wire line connection is selected even when it is ON.
(The SENSE and OUTPUT lines are internally jumpered.)

⑯ PROGRAM block keys

Use keys of this block to select one of the following four modes.

- 1) MEMORY: Stores data of channels 0 to 99 in the memory area.
- 2) RECALL: Recalls data from channels 0 to 99 of memory.
(Use the Random Channel Access, Step, Single, or Repeat mode for data recall.)
- 3) STEP TIME: Sets the step time between channels within the range of 1 to 99 seconds.

- 4) FIRST/LAST channel: Specifies the first and last scan channels in the Scan mode (for Step, Single, or Repeat scan).

⑥-1 MEMORY key

Selects the Memory mode (and its lamp lights).

MEMORY
 (lamp is off): Releases the Memory mode.

MEMORY
 (lamp is on): Selects the Memory mode.

(See Sections 3.5 and 3.5.3.)

CAUTION

1. You can set the generation data and V/I limit as the memory data.
2. In the Memory mode, the output is forcibly turned off (standby).
3. Use the (CHANNEL) key to set the desired channel in the Memory mode.

⑥-2 RECALL key

Selects the Recall mode (and its lamp lights). Also, use this key to select any desired key in the Memory or Recall mode.

RECALL
 (lamp is off): Releases the Recall mode.

RECALL
 (lamp is on): Selects the Recall mode. You can select one of four recall options.

- Random channel access
- Step
- Single
- Repeat

RECALL
 (lamp is on): Allows you to select any desired channel using the (CHANNEL) and (CHANNEL) keys in the Recall mode.

Channel data

(Random channel access)

(See Sections 3.5 and 3.5.3.)

CAUTION

The display data is output in the Recall mode. Check the output on/off status before operation execution.

⑩-3 STEP TIME key

- Sets the step time between channels during Single or Repeat scan. Also, use this key to check the setup.
Step time setup range: 1 to 99 seconds
- The step time can be set or checked in the Memory mode only.
(See Section 3.5.1.)

⑩-4 FIRST/LAST key

- Sets the first and last channel during Step, Single, or Repeat scan. Also, use this key to check the first or last channel.
First/last channel setup range: 0 to 99 channels
(The first channel must be equal to or less than the last channel.)
- The first and last channels can be set or checked in the Memory mode only.
(See Section 3.5.2.)

⑪ MODE key and recall display (and HOME key)

- Switches the memory data recall options between Random Channel Access, Step, Single, and Repeat modes. This key switches the modes between Step, Single, and Repeat Scan, and the selected mode is displayed in the display section.

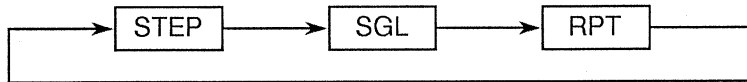

- Use this key to reset to the first channel during scan.

MODE
 : Returns to the first channel or HOME position during scan (in Recall mode).
(HOME)

(See Section 3.5.5.)

⑱ START key and lamp (and PAUSE key)

- Start the Scan mode (Step, Single or Repeat option).
- Use this key to pause (temporarily stop) any channel when starting scan.

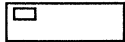
START
 (lamp is off): Displays the status before and after Step, Single, or Repeat scan.

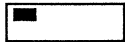
START
 (lamp is blinking): Displays the pause status during Single or Repeat scan.
 (PAUSE)

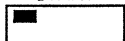
START
 (lamp is on): Shows the Step, Single, or Repeat mode scan is in progress.



(See Section 3.5.5.)

⑲ DATA ENTRY key block

- Use the DATA ENTRY keys to enter the voltage (including divider output), current output data, voltage/current limit, and various control parameters.



 : Polarity

 : Decimal point

 to  : Numerical data

 : Voltage output (1 V, 10 V, 100 V, or 1000 V range)

 : Current output (1 mA, 10 mA, or 100 mA)

Use these keys (, ) to switch the functions, and press it at the end of numerical data entry.

 : Cancels the input data during data setup.

 : Enters the specified program data, and various control parameters. Also, use this key to increment the channel data by 1 channel in the Memory mode.

⑩ POLARITY [+], [0] and [-] keys

Use the [+] or [-] key of POLARITY block to select the generation signal polarity.
Use the [0] key to cause zero generation.

Zero generation example:

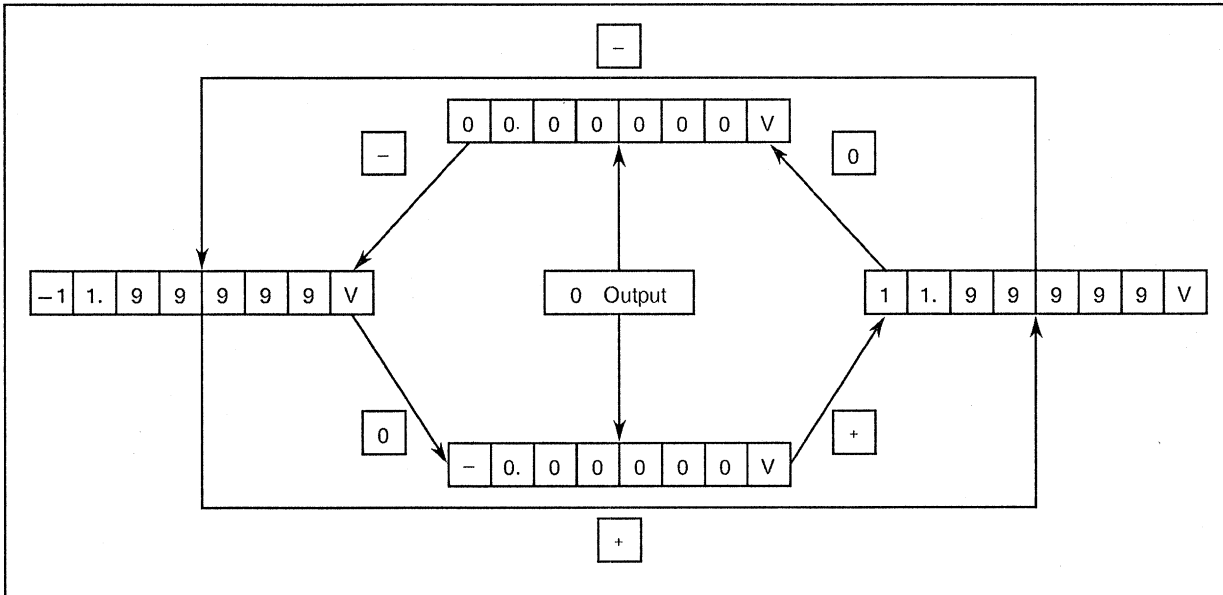

(See Section 3.3.4.)

* If you set [0], you can change the range or other values (V/I limit, EXT GUARD, and EXT SENSE).

⑩ RANGE key block

Use the RANGE keys to change the signal generation range (See Section 3.3.8).

AUTO (lamp is off): Allows manual range setup. Use the (Up) or (Down) key to change the range.

AUTO (lamp is on): Selects the auto range function to allow automatic selection of an appropriate range (at the maximum effective digits).

* Range Up level: 120% or more of the full scale
Range Down level: 12% or less of the full scale

* Selectable ranges in Auto Range mode

V function: Between 1 V, 10 V, 100 V and 1000 V ranges
DIV function: Between 10 mV, 100 mV and 1000 mV ranges
I function: Between 1 mA, 10 mA and 100 mA ranges

Range switch example:

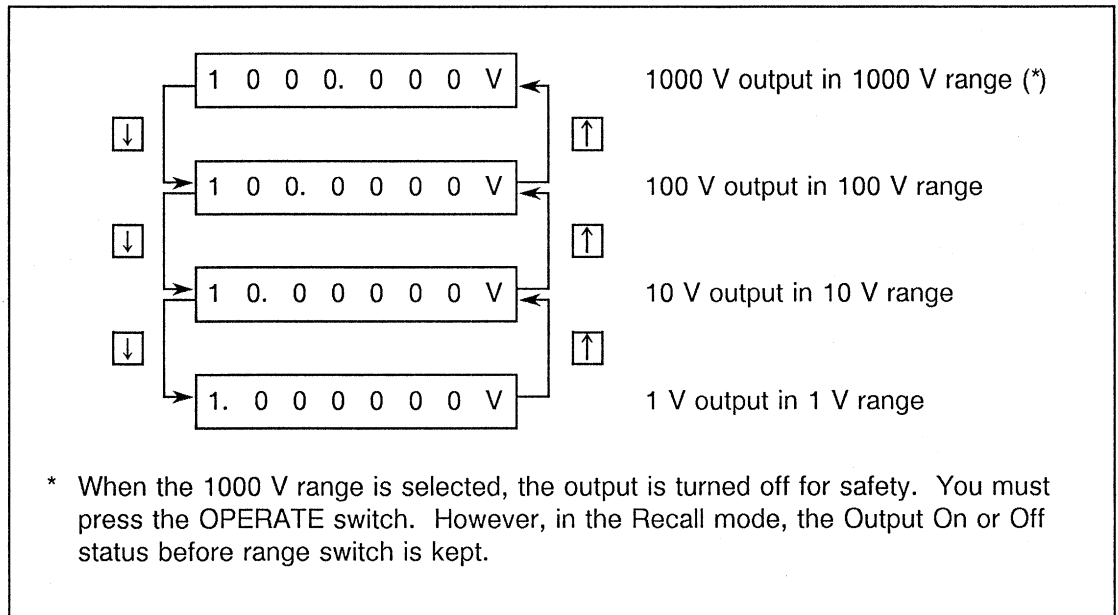

CAUTION

1. In the normal operation mode (direct operation), the output is turned off when the 1000 V range or 1 mA or 10 mA range of option 01 (with 1200 V output compliance) is selected. You must set the OPERATE status (Output On) again.
2. You must manually change the range in the Memory mode.
(When the Memory mode is selected, the Auto Range is released.)

2.3 Rear Panel

(See Figure 2-3 for switch and lamp layout on the Generator rear panel.)

① Selected power voltage and fuse indication

The Generator has the nameplate indicating the nominal source power voltage and fuse capacity. Before plugging the power cord into receptacle, make sure that your Generator has the correct power voltage and fuse capacity.

SET	~ LINE V	FUSE
●	90 ~ 110 V	T1A/250V
	103 ~ 132 V	
	198 ~ 242 V	T0.5A/250V
	207 ~ 250 V	

Marking →

Figure 2-1 100VAC Model (Example)

② Options

The Generator has the Option 01 function (with the expanded 1200 V output compliance for 1 mA or 10 mA). If option 01 is installed on your Generator, it is marked as follows.

INSTALLED OPTION 01	●	← Marking
------------------------	---	-----------

③ GND terminal

This terminal must be grounded.

When using the dual-pin adapter for the power cable plug, connect the adapter ground lead or the GND terminal to the earth.

The Generator front panel also has the GROUND terminal of the binding post (see ⑫ of Figure 2-2). However, you must use the rear-panel GND terminal for frame grounding.

④ Connector for AC power supply

Use this connector for AC power supply cord.

This connector has the slide cover for protection. Slide the cover to the left and plug the power cord of the accessory kit into the socket.

You can set one of four source voltages using the power cord at the power connector.

(See Sections 1.1.6 and 1.1.7.)

⑤ EXT CAL switch

Use this switch for calibration of each range and limit value.

Usually, set the EXT CAL switch to the DISABLE position. To start calibration, turn the power supply on and set this switch to the ENABLE position. This switch cannot be controlled from an external device. (See Chapter 7.)

CAUTION

You must set the EXT CAL switch to the DISABLE position except for calibration. If you set it to the ENABLE position, the calibration data may be updated.

⑥ EXT TRIG (External Trigger) input terminal

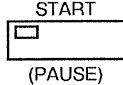
Use this terminal to select the Scan mode or start (or pause) the Generator using an external signal. Its functions are the same as those for  key ⑩ of the front panel (see Section 2.2).

The input signal is a negative pulse (with 10 μ sec or larger pulse width).

(See Section 5.6.)

⑦ GPIB connector

Use this connector for external control of the Generator and for data output (See Section 4.2.1).

⑧ REMOTE CONTROL connector

Use this connector for BCD remote control of the Generator (see Chapter 5).

⑨ Cooling fan

The fan exhausts the hot air for cooling down the inside of the Generator.

Never prevent the air flow (See Section 1.1.3, (1)).

⑩ Output terminal block

These terminals are the same as ⑨, ⑩, and ⑪ mounted on the front panel. Each terminal has the parallel connection between the front and rear panels. For the function explanation, see terminals ⑨, ⑩, and ⑪ of the front panel (See Section 2.2).

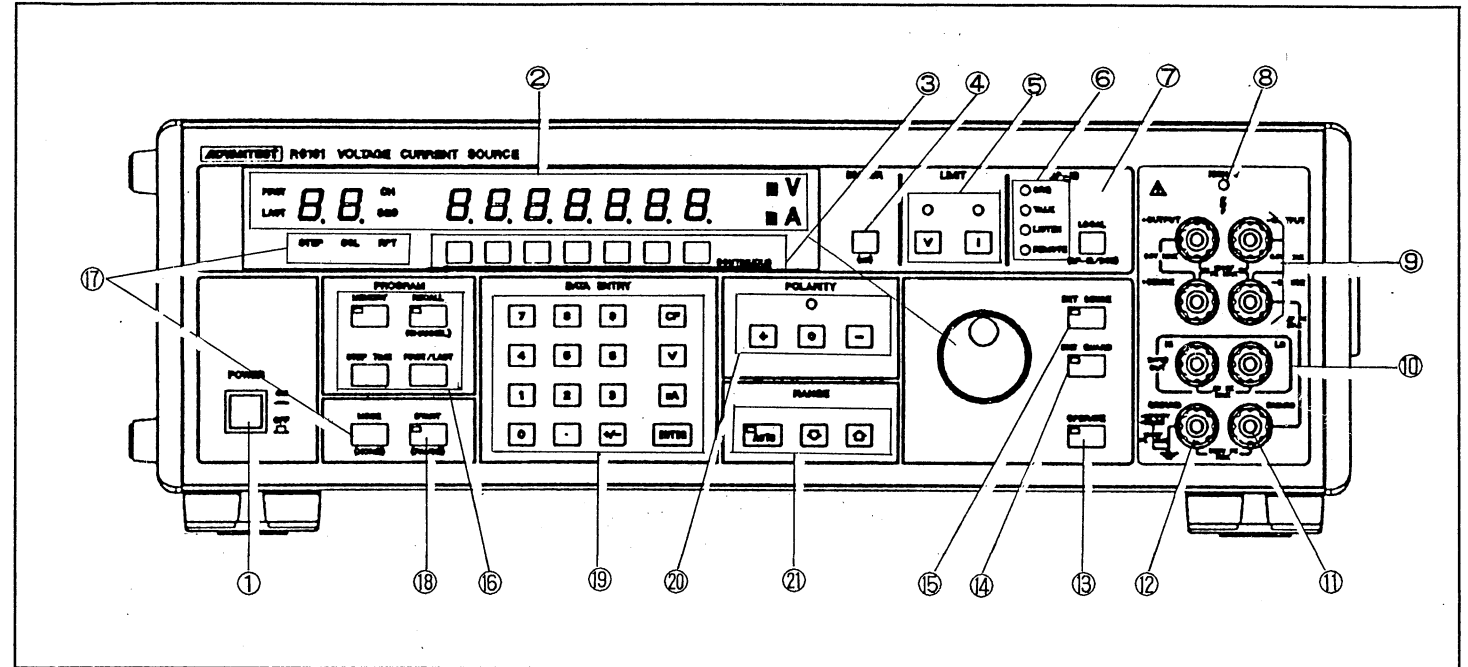

Figure 2-2 Explanation of the Front Panel

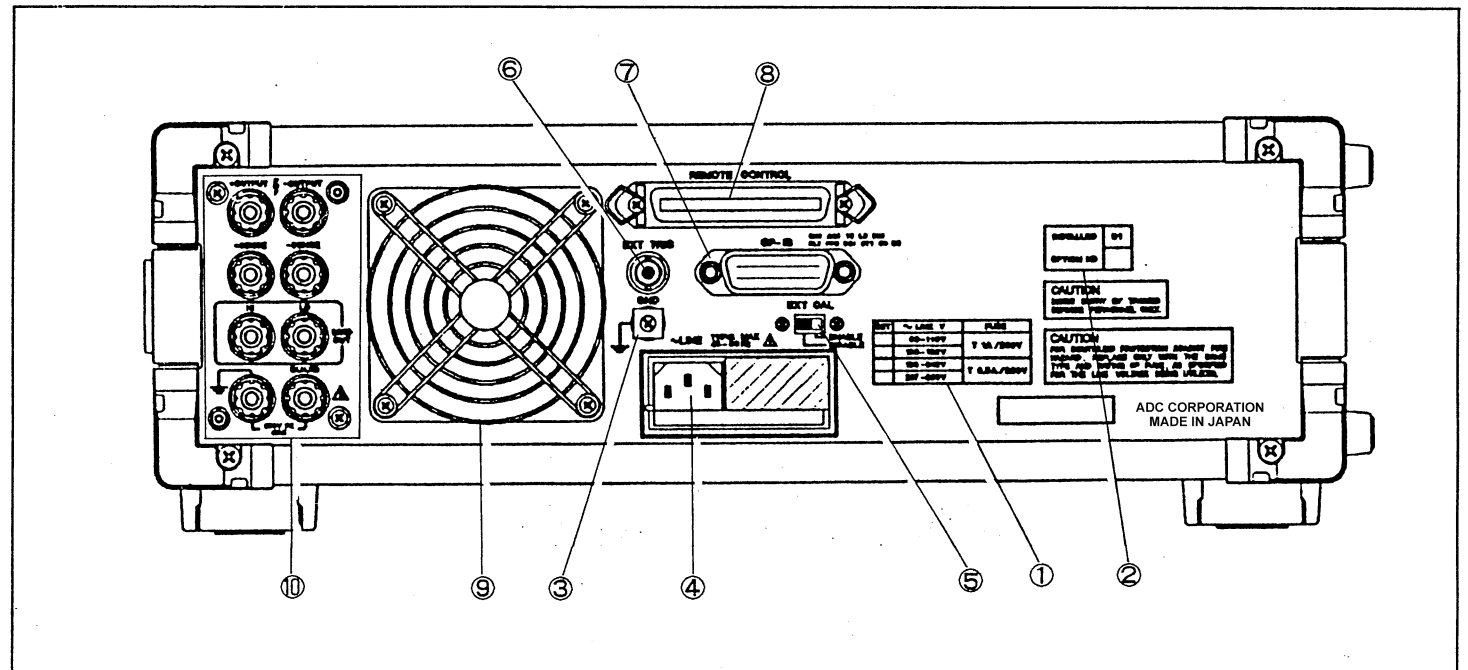

Figure 2-3 Explanation of the Rear Panel

3. OPERATIONS

3.1 Power ON and Startup Operations

3.1.1 Turning Power ON

Power-on procedure:

- (1) Make sure that the source voltage matches the nominal voltage printed on the rear panel of the Generator. Then, plug the power cable into the receptacle.
(See Sections 1.1.5 and 2.3 ①.)
- (2) Make sure that all output terminals are connected correctly, and turn the POWER switch on. Then, perform the startup procedure of Section 3.1.2.
(See Section 2.2 ①.)

3.1.2 Self-diagnosis and Revision and GPIB Address Indication

Operation explanation:

- ① When you turn the POWER switch on, the self-diagnostic program of the Generator starts automatically.
- ②-1 If the Generator is normal, all LED lamps light on the front panel during self-diagnosis.
- ②-2 If an error is found, an error code is displayed on the panel.
(See Section A1.5.4.)
- ③ When the self-diagnosis has terminated normally, the display changes as follows.
Display of model name → Display of software revision number → Display of GPIB address and its operation mode (R6161 mode or TR6120A compatible mode)

④ The Generator enters the initial setup status (explained in Section 3.1.3).

- Display of software revision number

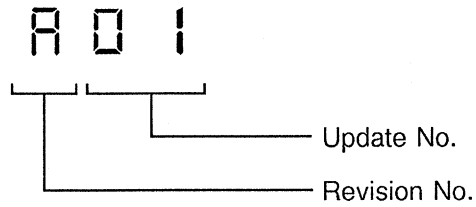

- GPIB address and its operation mode

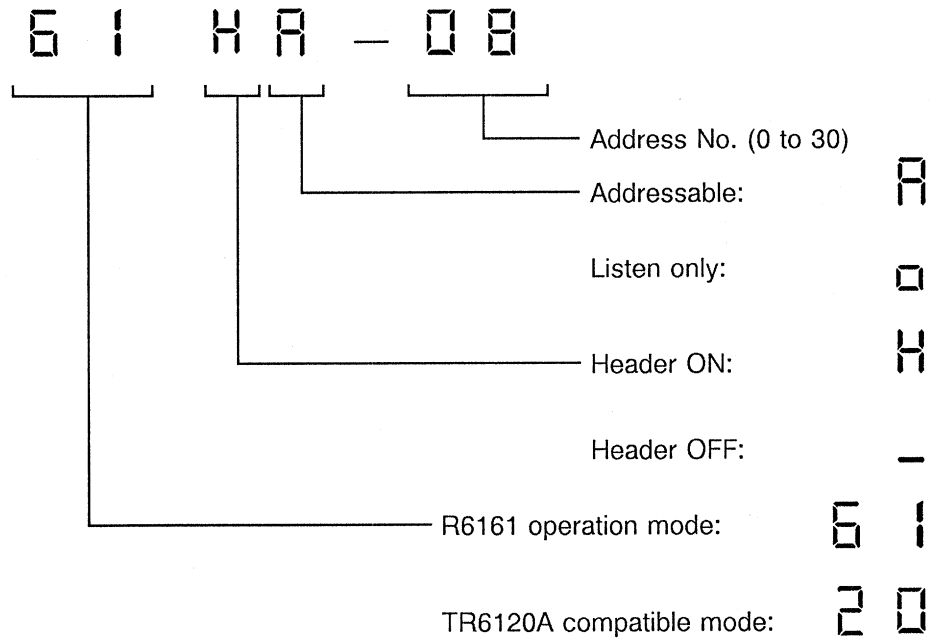

3.1.3 Initial Parameter Setup

Operation explanation:

(1) When the self-diagnosis terminates normally, the Generator enters the initial setup status. Table 3-1 summarizes the initial setup status (standard parameter setup during delivery) and the parameters that can be backed up.

(2) Hold down the CE key and turn the POWER switch on, and the Generator will also enter the initial setup status of Table 3-1.

Table 3-1 Initial Setup Status (Standard Parameter Setup during Delivery)

Item	Initial setup status	Backup
Generation function	VOLTAGE	×
Range	1V range	×
Voltage generation value	+ 0.000000 V	×
Voltage limit	130 V	×
Current limit	125 mA	×
AUTO RANGE	ON	×
OPR/STBY	Standby (Output Off)	×
Memory data (0 to 99 channels)	Range: 1 V VL: 130 V Data: 0 V IL: 125 mA	○
First channel	00cH	○
Last channel	99cH	○
Scan mode	Step	○
Step time	1sec	○
EXT-GUARD	OFF	○
EXT-SENSE	OFF	○
*GPIB	R6161 mode	○
	Header: On	○
	Addressable	○
	Address: 08	○

* You can change the GPIB header on/off, only mode and address on the Generator panel only. Also, you can set or release the BCD Remote Control mode on the Generator panel only.

3.2 Before Startup

3.2.1 Explanation of Basic Operations

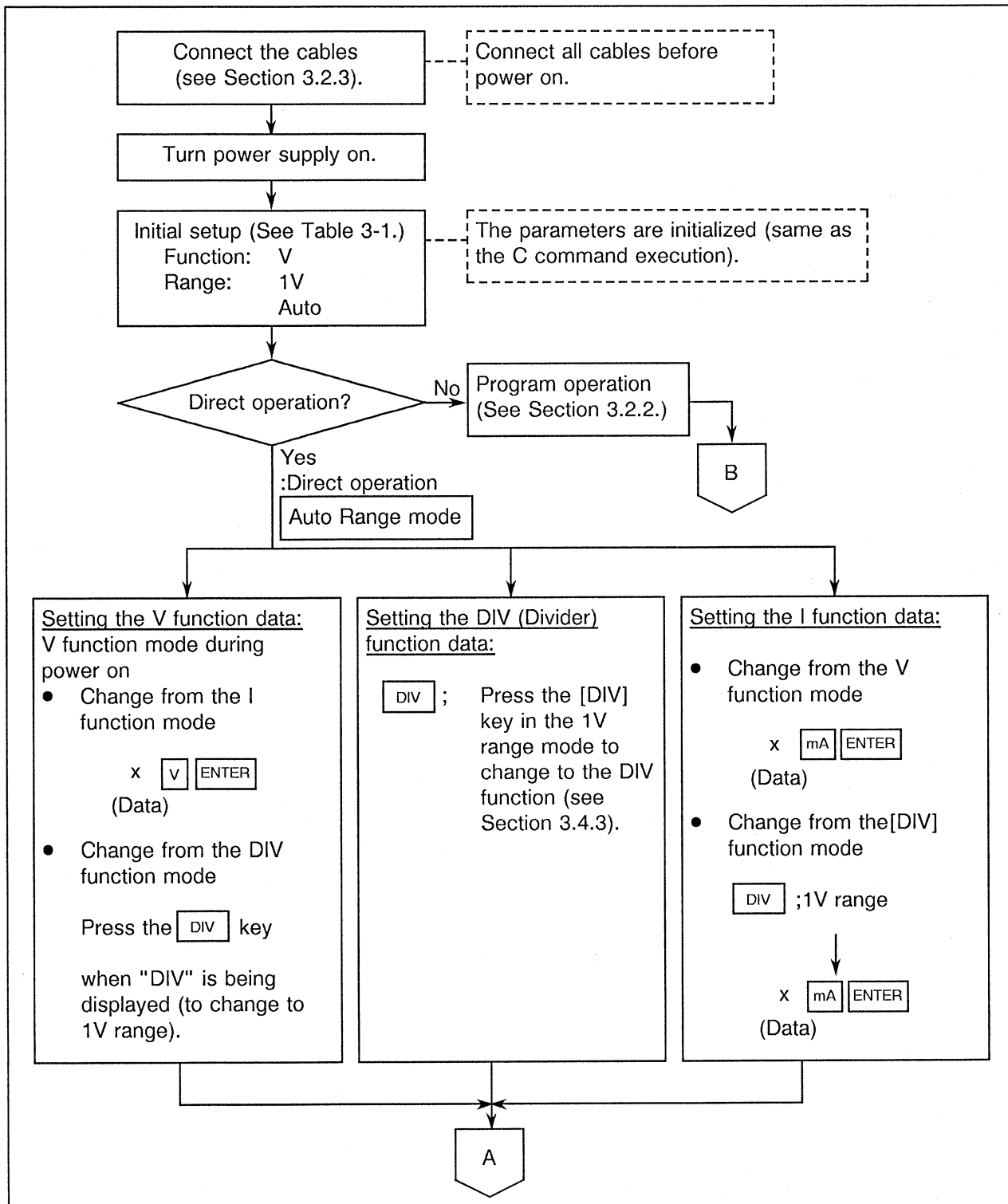

Figure 3-1 Basic Operation Flow

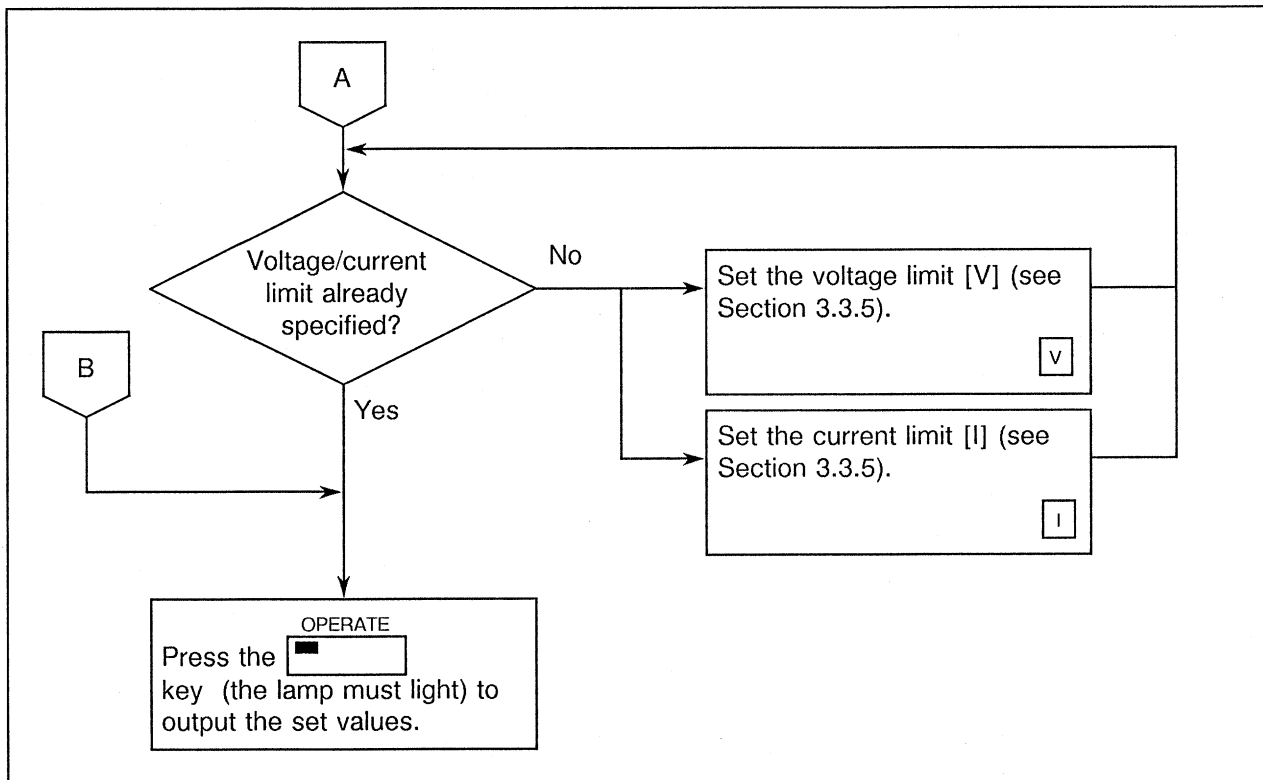
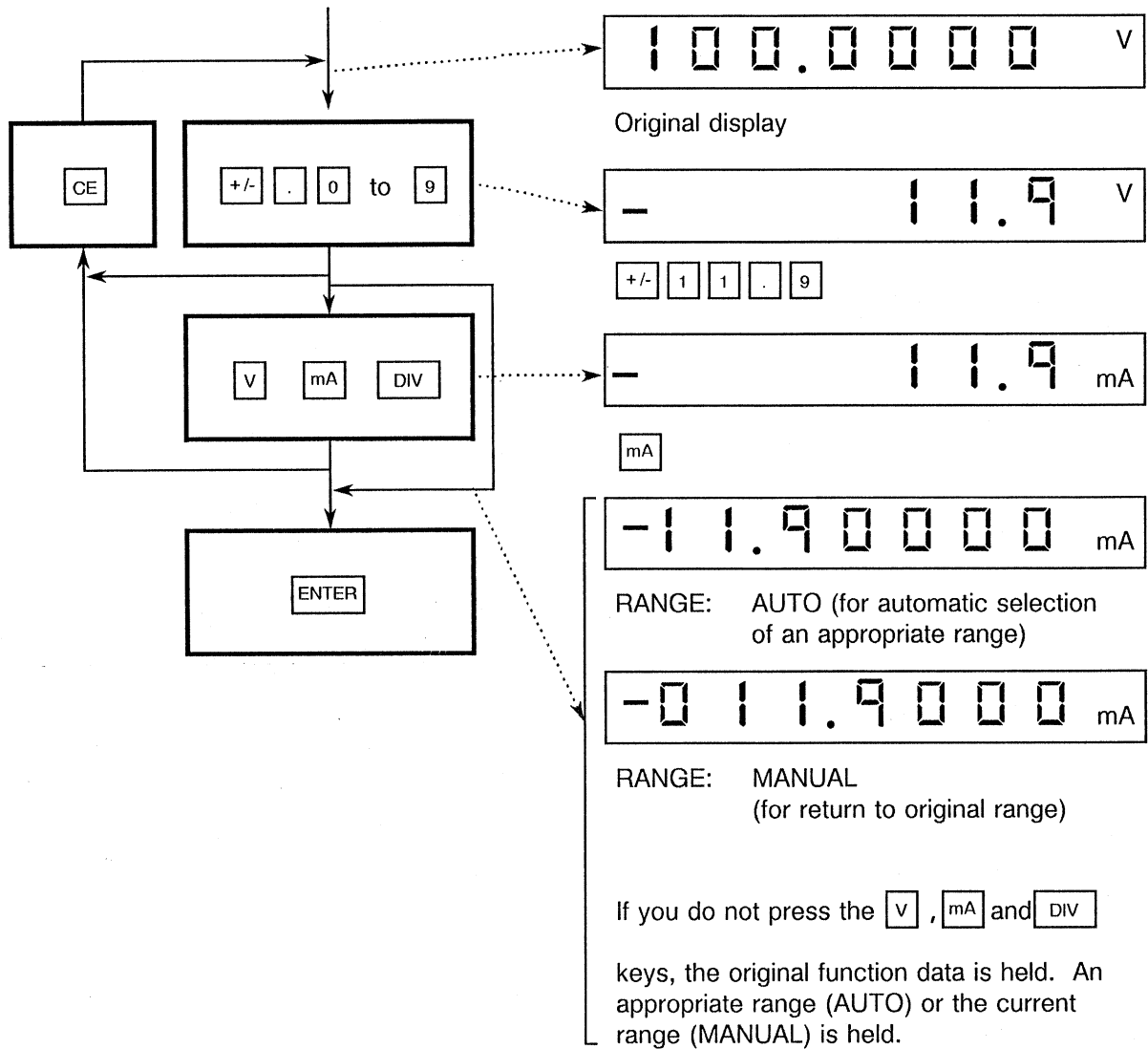

Figure 3-1 Basic Operation Flow (Cont'd)

R6161 PROGRAMMABLE REFERENCE
DC VOLTAGE/CURRENT GENERATOR
INSTRUCTION MANUAL

3.2 Before Startup

(1) Data input during direct operation



CAUTION

1. Switching between V function and DIV (1000mV, 100mV, or 10mV divider) function
 - The DIV key is effective only in the 1V range to switch from the V function to DIV function. (When you press the DIV key, the "mV" and "DIV" are displayed.)
 - To switch from the DIV function to V function, release the DIV function mode ("mV" display will change to "V"). (The 1V range will be set.)
2. Switching between DIV and I functions
 - Select the 1V range of the V function first, then select the DIV or I function mode.
3. Switching between V and I functions

Enter numerical data, press the or key, and press the key in this sequence.

- (2) Data input during memory data processing
The basic operation is the same as that of direct operation (Step 1).

CAUTION

1. The Manual Range is set.
2. The key can set "mV" only (same as "V" or "mA") for divider setup (10 mV, 100 mV or 1000 mV). You can set x (Data), (mV) and .
3. The default voltage or current limit of the selected range is set when you press the key for the output data or when you change the range.

(3) Voltage/current limit operation

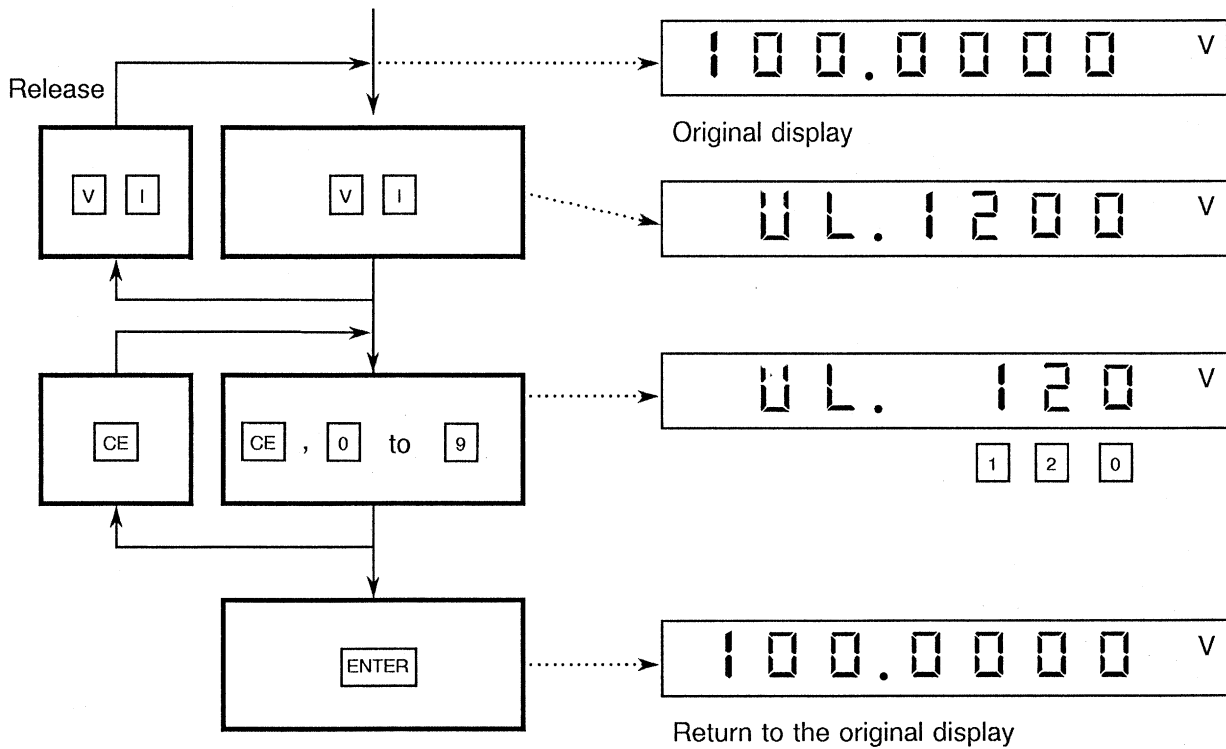

CAUTION

If you press the **CE** key during data input, the previous data is redisplayed (see Section 3.3.5).

(4) Data control knob

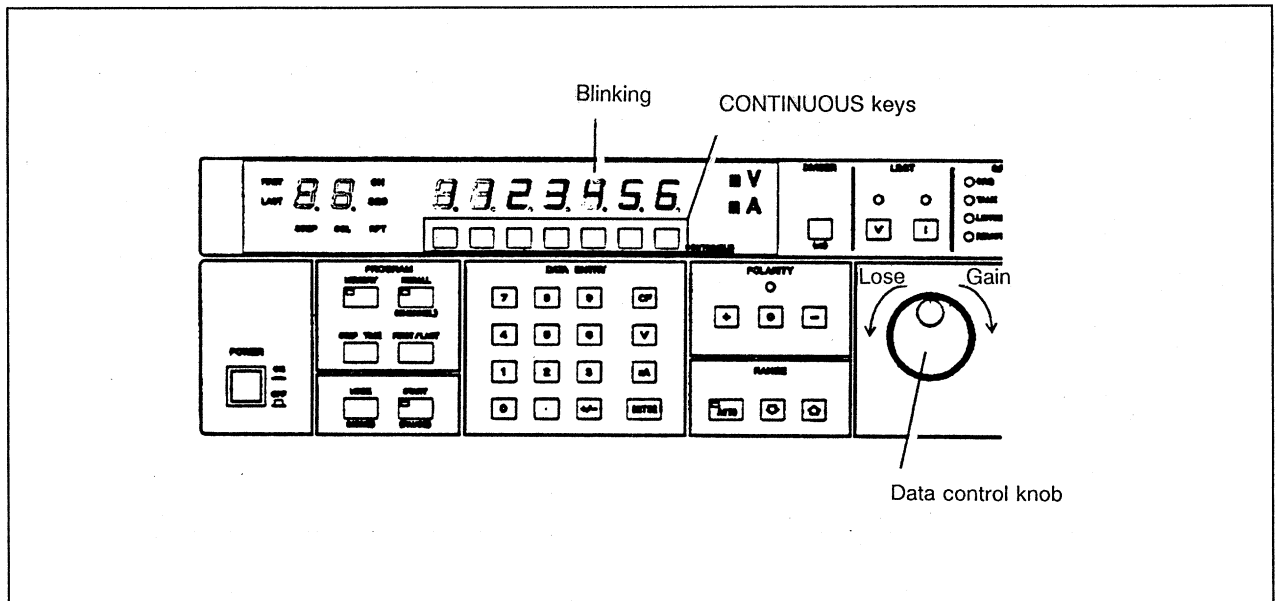



- You can specify to decrease (to zero) or increase (to the full scale) from the point specified by the CONTINUOUS keys.
In the setup shown above, you can increase or decrease the value between 0.000056 V and 1.199956 V in the MANUAL range. While in the AUTO range, it is changed to an appropriate range (the maximum effective digits).

(5) POLARITY

- Set the polarity of the generation signals using the or key.
(These keys are effective for generation signal only.)
- The key sets the value to zero.
(When set to zero, the MANUAL range is selected.)

(6) RANGE

- Set the range using the  or  key.

Operation example:

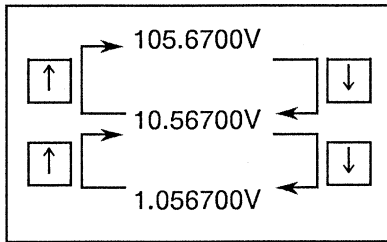

Operation example (with DIV):

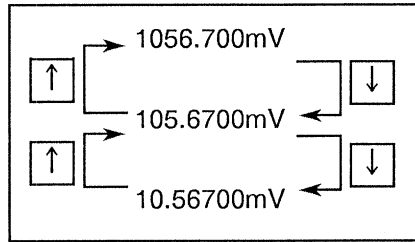

CAUTION

When the range is changed, the output data is incremented or decremented in the decade unit as shown in these examples.

Table 3-2 Appropriate Setup Range and V/I Limit Setup Range

RANGE	Setting range	V limit range	I limit range
10 mV } 100 mV } DIV 1000 mV }	0 to 11.99999 mV 12 mV to 119.9999 mV 120 mV to 119.9999 mV	*1 —	*1 —
1 V 10 V 100 V	0 to 1.199999 V 1.2 V to 11.99999 V 12 V to 119.9999 V	10 V to 130 V	1 mA to 125 mA
1000 V	120 V to 1199.999 V	10 V to 1250 V	1 mA to 13 mA
1 mA 10 mA 100 mA	0 to 1.199999 mA 1.2 mA to 11.99999 mA 12 mA to 119.9999 mA	*2 10 V to 130 V	1 mA to 125 mA

*1 The DIVIDED output is equal to the 10 V range output attenuated by 1/10, 1/100 or 1/1000. The limit of the output level in each range is as follows.

*2 If option 01 for 1 mA or 10 mA range (output compliance) is installed, the 1 mA/10 mA range is set to the 10V to 1250 V voltage limit range.

**R6161 PROGRAMMABLE REFERENCE
DC VOLTAGE/CURRENT GENERATOR
INSTRUCTION MANUAL**

RANGE	V limit value	Limit value (if output terminal is jumpered)
10 mV 100 mV 1000 mV	20 mV 200 mV 2 V	Approx. 60 μ A MAX Approx. 600 μ A MAX Approx. 6.6 mA MAX

The diagram illustrates a resistor ladder circuit. It consists of a vertical chain of four resistors: 180K, 18K, 1.8K, and 200Ω. Three range-select switches are connected to the nodes between the resistors: the 10mV switch is connected to the top node, the 100mV switch to the node between the 180K and 18K resistors, and the 1000mV switch to the node between the 18K and 1.8K resistors. The output terminal is connected to the node between the 1.8K and 200Ω resistors. The bottom of the 200Ω resistor is connected to a common ground point.

3.2.2 Program Operation Flow

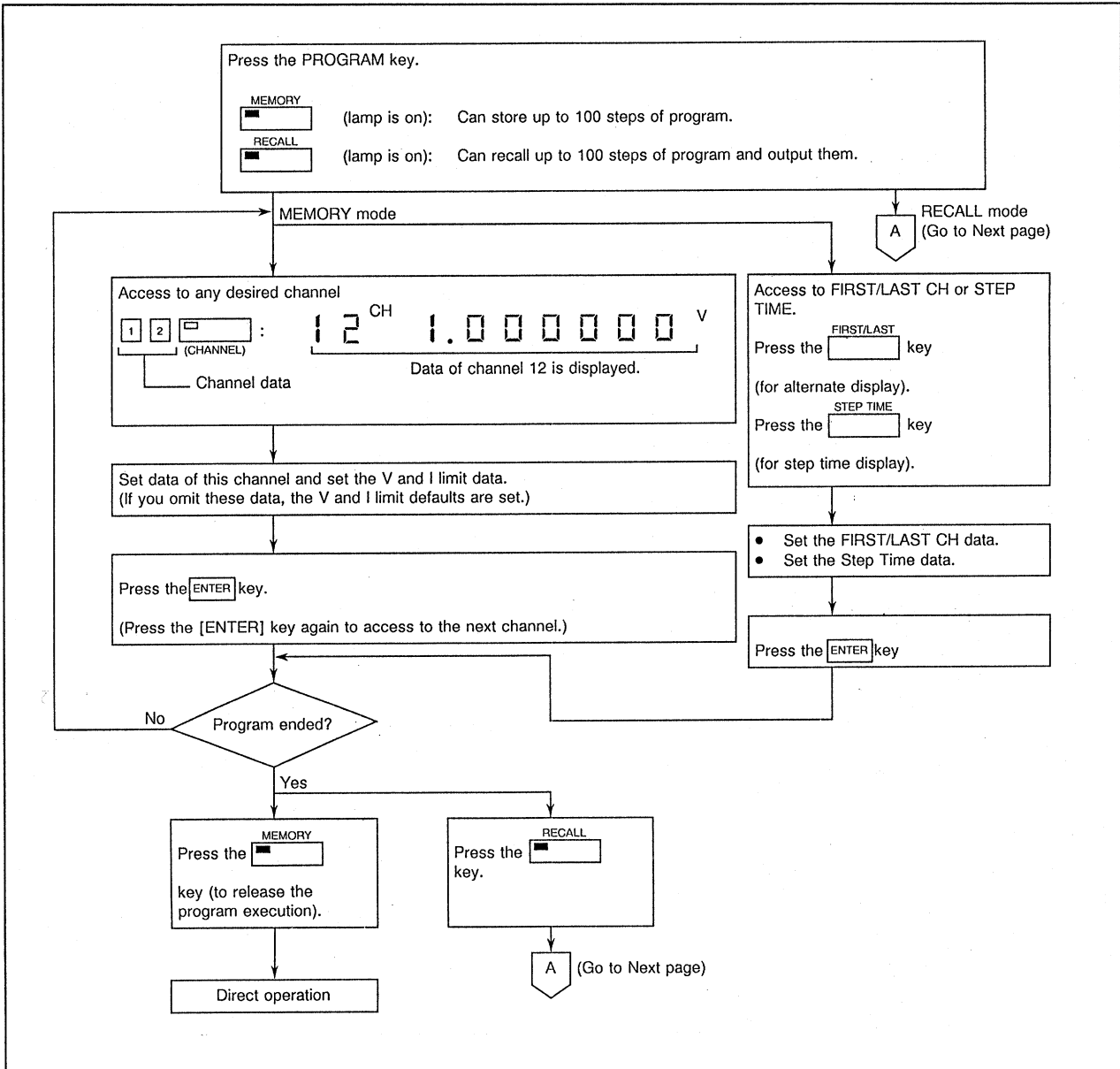

Figure 3-2 Program Operation Flow

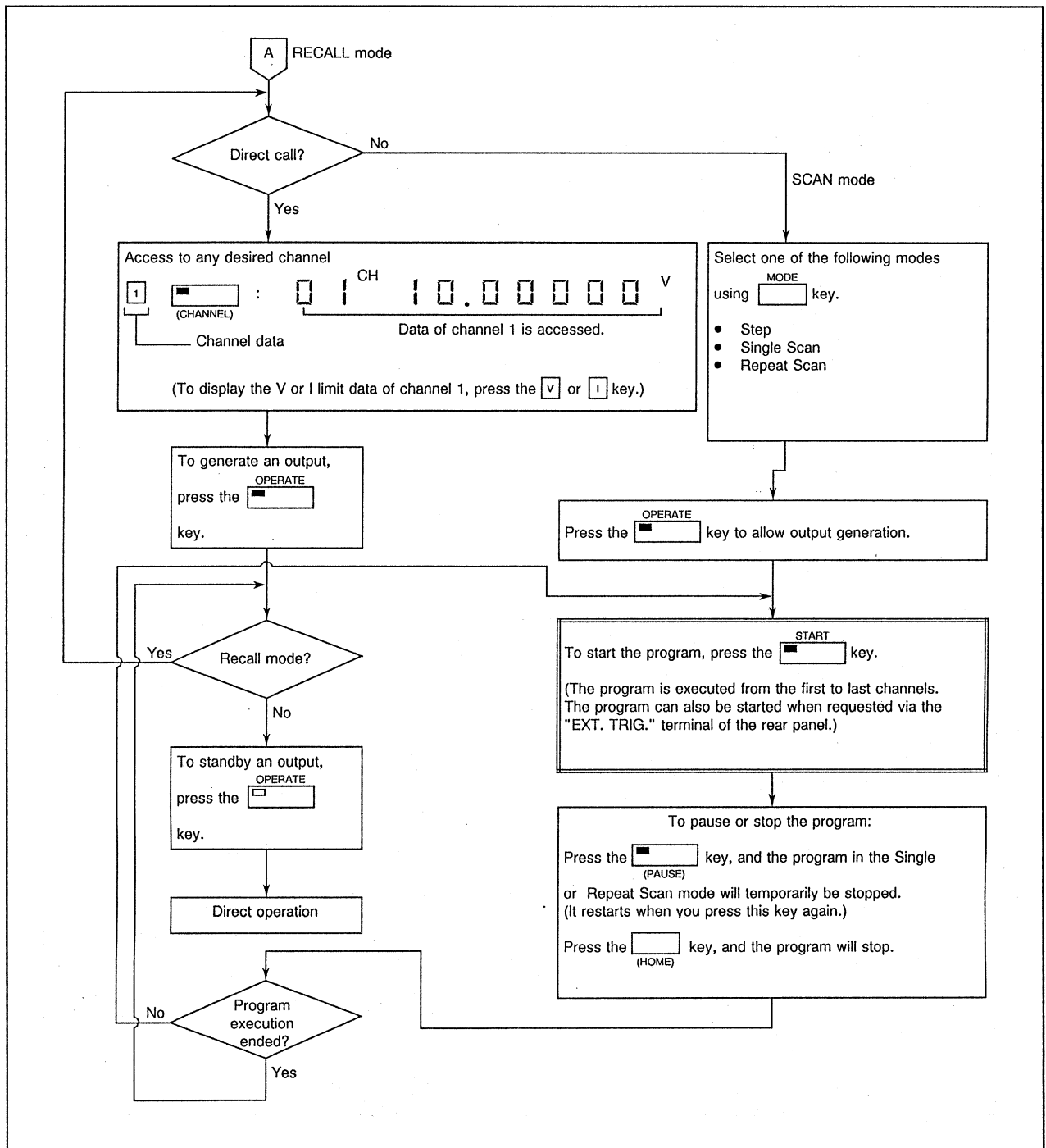

Figure 3-2 Program Operation Flow (Continued)

3.2.3 Connection to Loads

(1) Configuration of output terminals

The Generator has the positive (red) and negative (black) signal output terminals. They are four output terminals: the positive and negative OUTPUT terminals and the positive and negative SENSE terminals.

Usually, use the same polarity of OUTPUT and SENSE terminals by pressing the

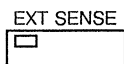

key (the lamp is off) for jumpering (2-wire line).

(2) How to use four terminals

If the cable voltage drop cannot be ignored in the 1V, 10V, 100V or 1000V voltage range,

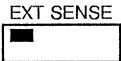
select the "4WIRE" mode by using the  key (the lamp must light) to select the 4-wire line.

(3) Operation with 2-wire or 4-wire line

Figure 3-3 shows the equivalent circuit when the 2-wire or 4-wire line (the EXT SENSE lamp is on) is used.

The figure shows the equivalent circuit when the positive polarity of the Generator has been set.

The Generator flows the voltage detect current (I_s) when it is set at the full-scale mode ($40\mu\text{A}/1\text{V}$ range, or $100\mu\text{A}/10\text{V}$, 100V or 1000V range). Therefore, if the load current (I_o) is less than the voltage detect current, use the 2-wire line (the OUTPUT and SENSE terminals are jumpered by the SENSE switch) to improve the accuracy.

For example, use the 2-wire line when connecting a load having the high impedance such as a digital multimeter.

If the load current is greater than the voltage detect current, use the 4-wire line (that connects the OUTPUT and SENSE terminals at the load side). Table 3-3 provides the resistance of the cable connected to the SENSE terminal and its error. Also, Table 3-4 provides the resistance of the cable in the unit meter.

CAUTION

1. " V_D " voltage must be approximately 0.1 V or less to satisfy the requirement of " $V_o = E_o - (r_1 + r_4)I_s$ " of Figure 3-3. (If $V_D = 0.1$ V, an error equal to or less than 0.001% occurs.)
2. If the " V_d " value exceeds 0.1 V, the output is not reliable. Also, if the line is opened between the OUTPUT and SENSE terminals, V_D is approximately 0.7 V and the Generator is protected.
3. As the output resistance of the 2-wire line is approximately 100 m Ω (the load resistance is 100K Ω if the error is 1 ppm), use the 4-wire line to flow the load current.

R6161 PROGRAMMABLE REFERENCE
 DC VOLTAGE/CURRENT GENERATOR
 INSTRUCTION MANUAL

3.2 Before Startup

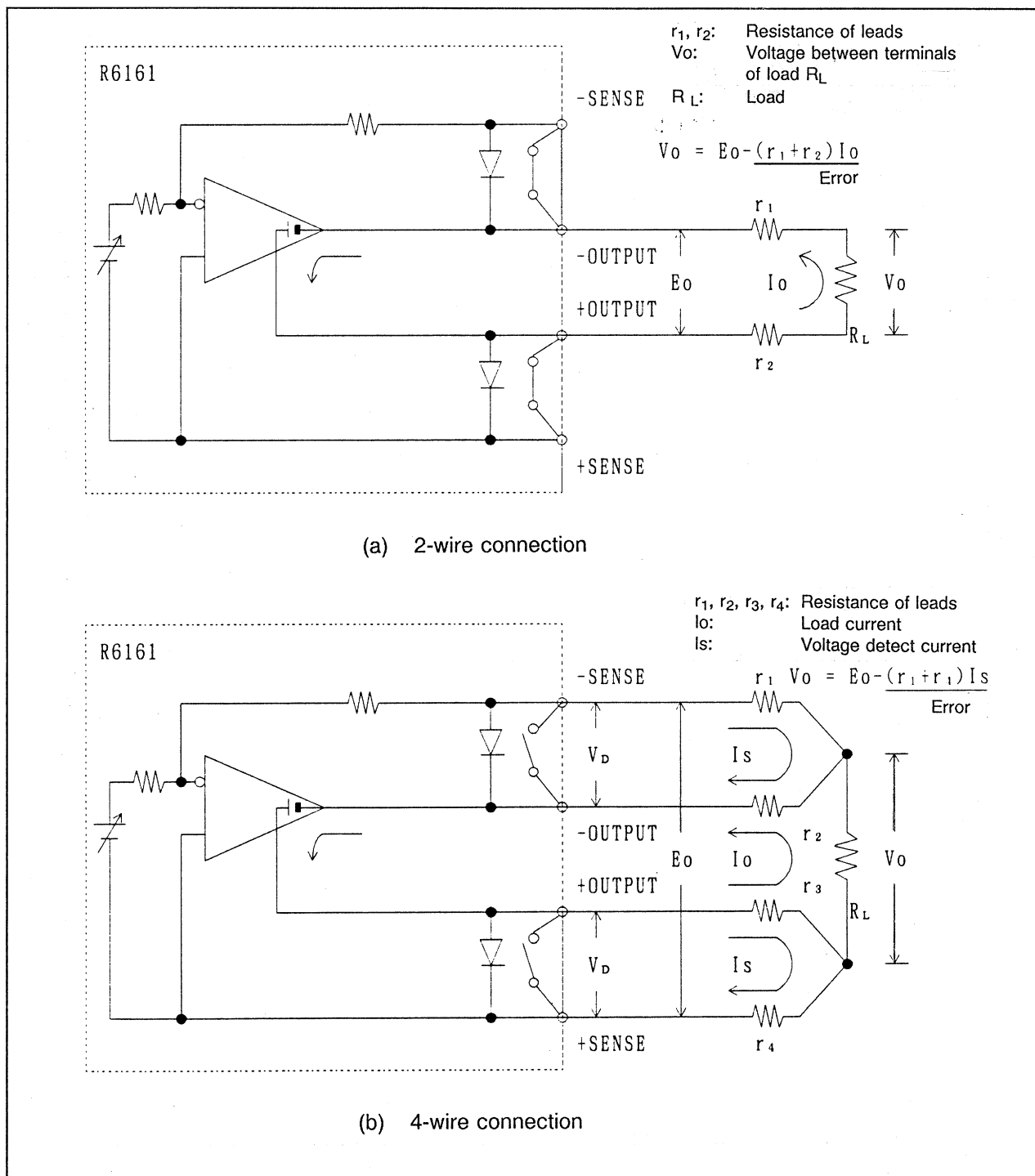

Figure 3-3 Equivalent Circuit

Table 3-3 Error due to Cable Resistance of 4-Wire Line

RANGE	r_1 or r_4 resistance	Error
1 V	250 m Ω	Approximately 0.001%
10 V	1 Ω	Approximately 0.001%
100 V	10 Ω	Approximately 0.001%
1000 V	100 Ω	Approximately 0.001%

Table 3-4 Resistance in Each Cable Unit Meter

Nominal section	Conductor resistance
0.08 mm ²	Approximately 270 m Ω /m
0.2 mm ²	Approximately 100 m Ω /m
0.3 mm ²	Approximately 62 m Ω /m
0.5 mm ²	Approximately 37 m Ω /m

3.2.4 How to Use GUARD Terminal (for noise protection)

The generation of electrical noise must be considered during high-speed, high accuracy, and high resolution measurement. In the measuring system, the noise occurring between the signal source and load and ground of the instrument is called the common mode noise voltage (CMV). Most of the noise components are AC power frequency and harmonic waves.

The CMV level greatly varies depending on the cable connection layout and the internal structure of voltage/current source. The Generator has the guard structure to have the largest CMV elimination rate.

You should use the GUARD terminal of the Generator if the output signals are multiplexed with electrical noise and it may affect on the measurement or test results. As shown in Figure 3-4, open the switch (EXT. GUARD) of the line between the GUARD terminal and an – output terminal. To prevent an induction, the Generator uses the shielded cable. Connect a single end of the cable to the GUARD terminal and connect the other end to the low-impedance terminal (together with the output terminal) when viewed from the load contact point. The optional BI-109, dual-core shielded cable is also available.

Figure 3-4 shows the 2-wire line connection to the GUARD terminal and Figure 3-5 shows the 4-wire line connection.

CAUTION

If you use two or more Instruments for signal measurement or test, all ground lines must be grounded at the same point. If not, the different ground potential may cause a CMV noise. In such case, you must connect all ground leads to a single ground point to reduce the CMV noise.

**R6161 PROGRAMMABLE REFERENCE
DC VOLTAGE/CURRENT GENERATOR
INSTRUCTION MANUAL**

3.2 Before Startup

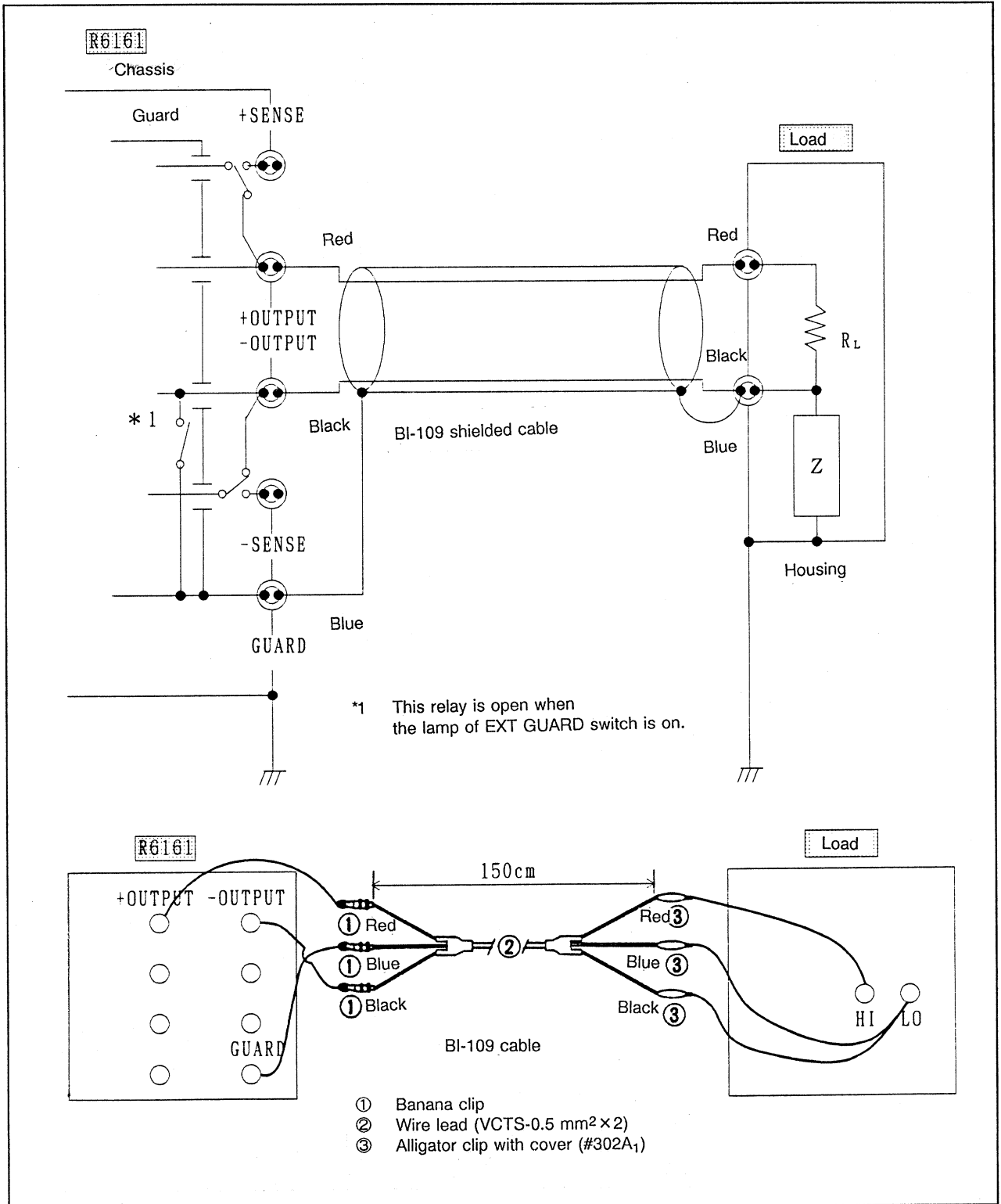

Figure 3-4 How to GUARD Terminal (for 2-wire line)

R6161 PROGRAMMABLE REFERENCE
DC VOLTAGE/CURRENT GENERATOR
INSTRUCTION MANUAL

3.2 Before Startup

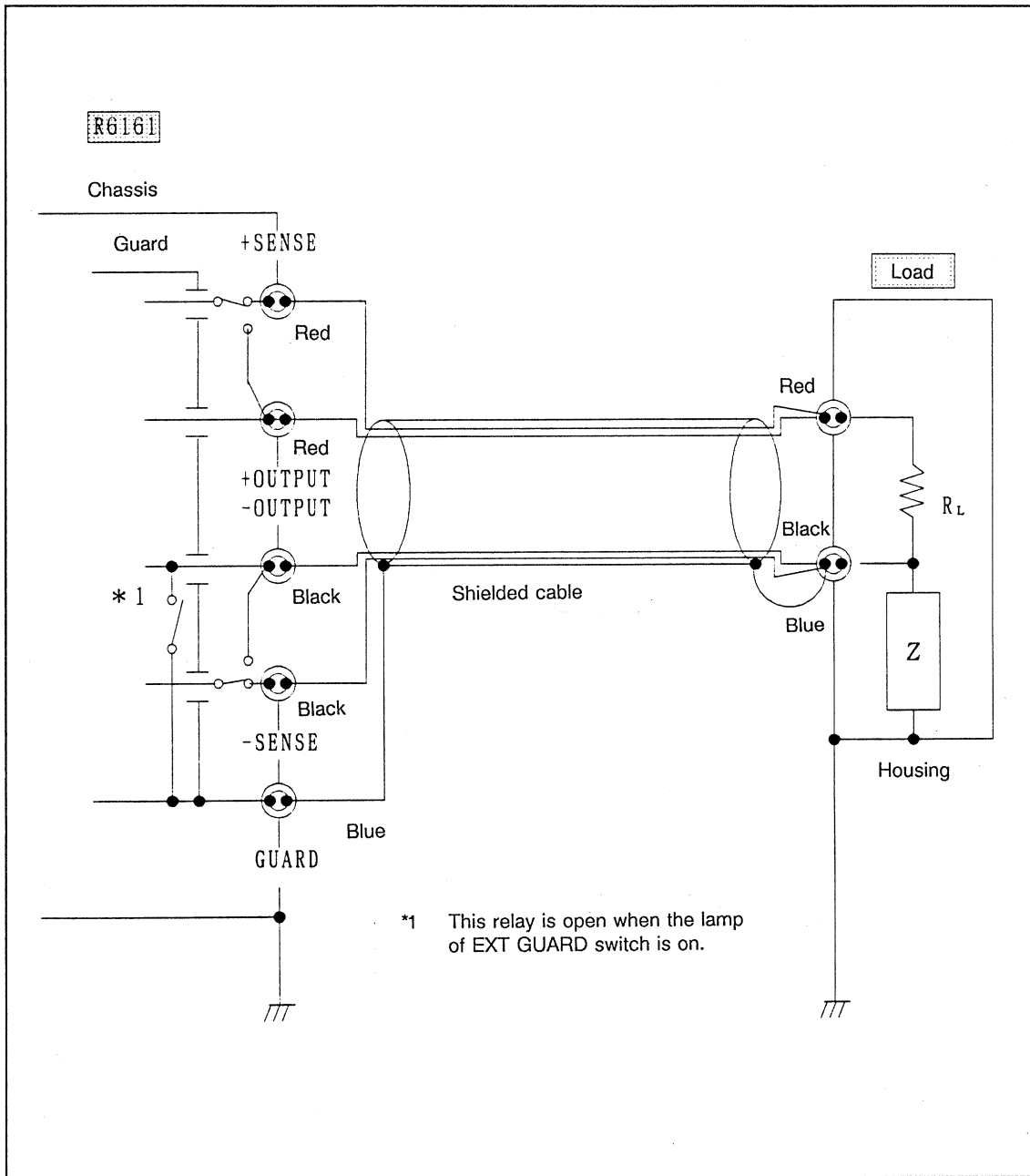

Figure 3-5 How to Use GUARD Terminal (for 4-wire line)

3.3 Standard Operations

3.3.1 Voltage Generation (during direct operation)

The following explains how to generate the 10VDC voltage.

Numbers ① to ⑤ of the figure correspond to the step numbers of the standard operation procedure.

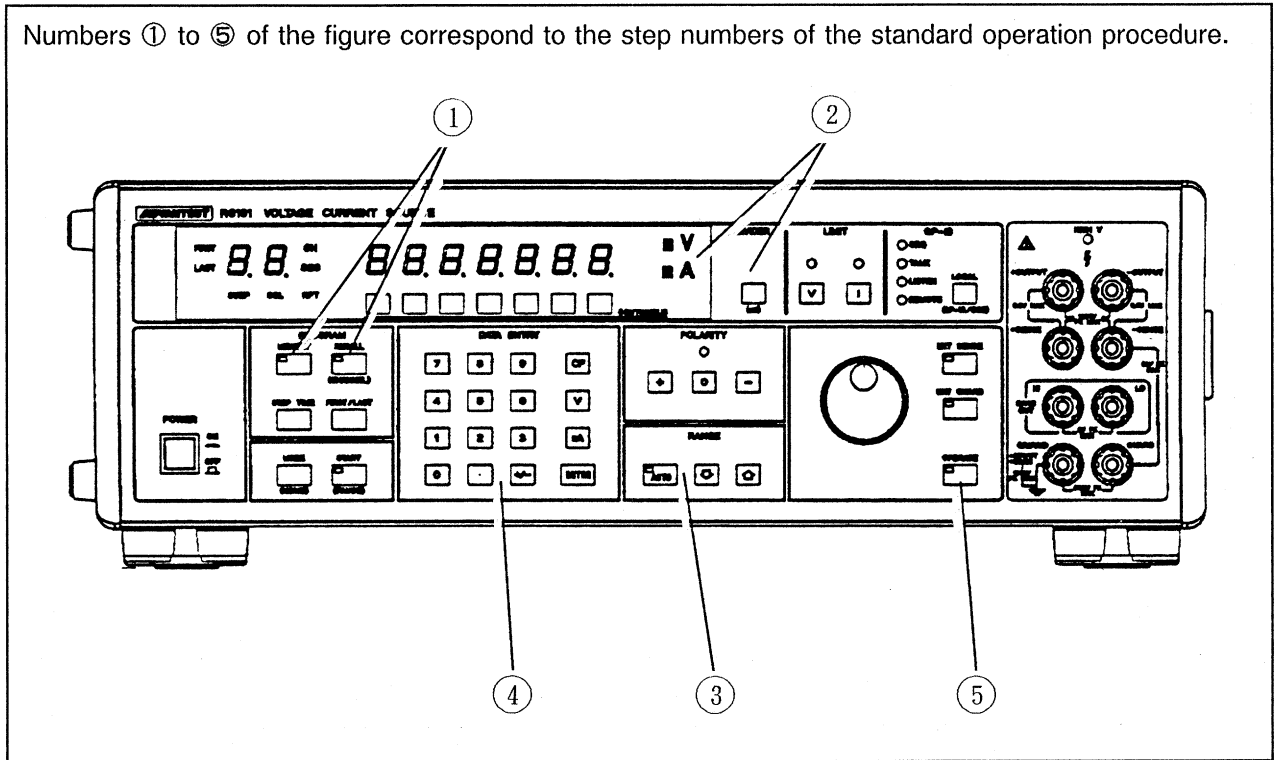

R6161 PROGRAMMABLE REFERENCE
DC VOLTAGE/CURRENT GENERATOR
INSTRUCTION MANUAL

3.3 Standard Operations

Operation procedure:

- ① Make sure that your Generator is NOT in the Memory or Recall mode.

(Both the ^{MEMORY} and ^{RECALL} lamps must be off.)

- ②-1 Make sure that the unit of "V" or "mA" is being displayed.

- ②-2 If "mV" [DIV] is displayed, press the ^{DIV} key to release it.

- ③ Set the RANGE to "AUTO" mode.

- ④ Press the 1 , 0 , V , and ENTER keys in this sequence to set 10 V.

Display:

- If "V" was already displayed before setup, you may omit the v key.
- To generate a negative voltage signal, press the +/- key before numerical data input.
- To check the V or I limit, press the V or I key, respectively.

(See Section 3.3.5 for setup.)

- ⑤ Press the ^{OPERATE} key to set "OPERATE ON" (Output ON).

(The lamp of ^{OPERATE} key must be on.)

3.3.2 Current Generation (during direct operation)

The following explains how to generate the 105.1 mA current.

Numbers ① to ⑤ of the figure correspond to the step numbers of the standard operation procedure.

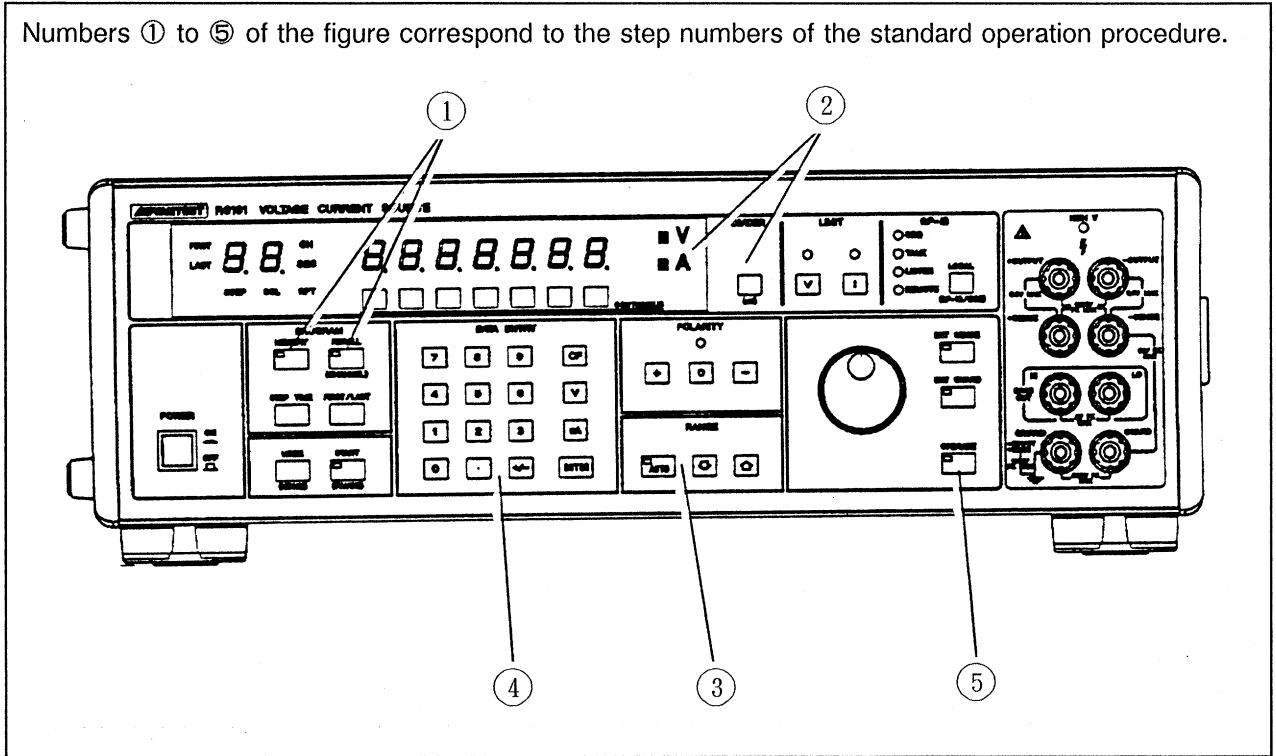

Operation procedure:

- ① Make sure that your Generator is NOT in the Memory or Recall mode.

(Both the ^{MEMORY} and ^{RECALL} lamps must be off.)

- ②-1 Make sure that the unit of "V" or "mA" is being displayed.

- ②-2 If "mV" [DIV] is displayed, press the ^{DIV} key to release it.

- ③ Set the RANGE to "AUTO" mode.

- ④ Press the 1 0 5 . 1 mA and ENTER keys in this sequence to set 105.1 mA.

Display:

- If "mA" was already displayed before setup, you may omit the mA key.
- To generate a negative current signal, press the +/- key before numerical data input.
- To check the V or I limit, press the V or I key, respectively.
(See Section 3.3.5 for setup.)

- ⑤ Press the ^{OPERATE} key to set "OPERATE ON" (Output ON).

(The lamp of ^{OPERATE} key must be on.)

Make sure that the load has been connected and start current generation.

3.3.3 Divide (DIV) Output Generation (during direct operation)

The following explains how to generate the 8.5mV DIV output.

Numbers ① to ⑥ of the figure correspond to the step numbers of the standard operation procedure.

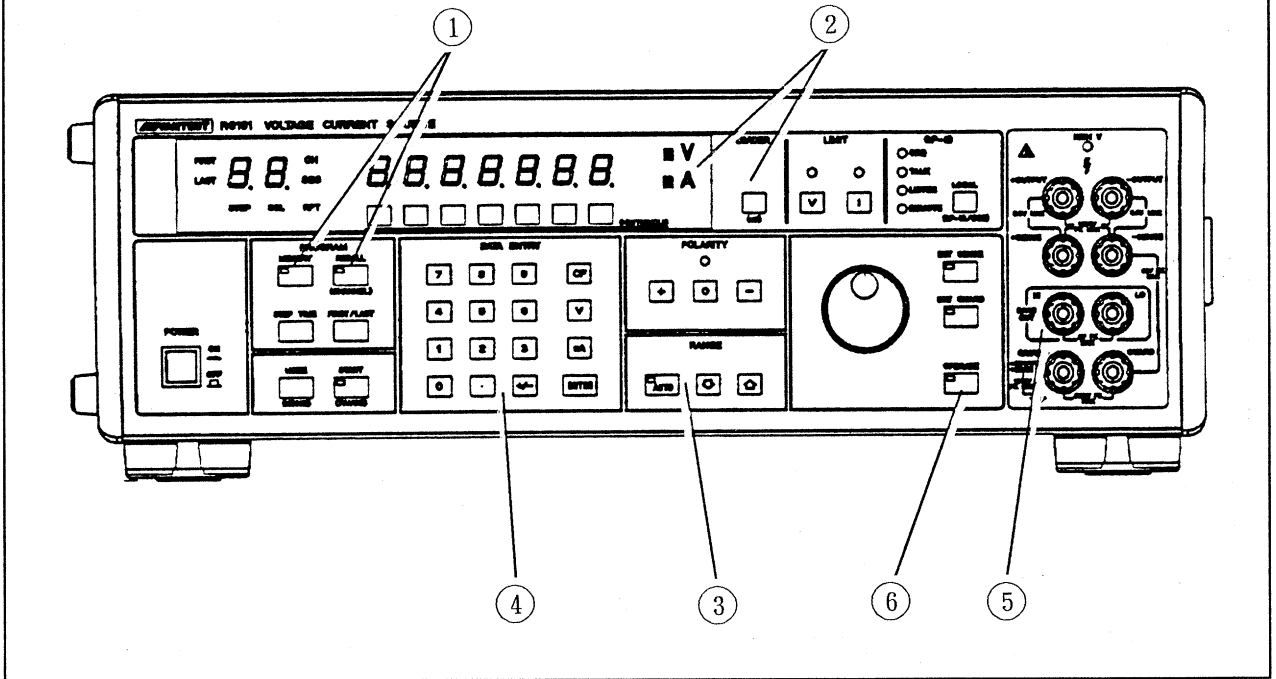

Operation procedure:

- ① Make sure that your Generator is NOT in the Memory or Recall mode.

(Both the ^{MEMORY} and ^{RECALL} lamps must be off.)

- ②-1 Make sure that the unit of "mV" (DIV) is being displayed.

- ②-2 If a unit other than "mV" is displayed, use the ^{DIV} key to set the "mV" (DIV).

(a) For "V" display: Select the "1V" range by keys ③ in figure and press the ^{DIV} key.

(b) For "mA" display: Select the "1V" range by keys ③ in figure and press the ^{DIV} key.

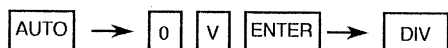

Note: To change to the Divider mode, set the 1000 mV, 100 mV or 10 mV after the 1V range setup.

- ③ Set the RANGE to "AUTO" mode.

- ④ Press the 8 . 5 and ^{ENTER} keys in this sequence to set the 8.5mV DIV output.

Display: mV

- To generate a negative voltage signal, press the ^{+/-} key before numerical data input.

- No V or I limit can be set (see Table 3-5).

- ⑤ Make sure that the signal cable has been plugged into the DIVID OUT terminal.

- ⑥ Press the ^{OPERATE} key to set "OPERATE ON" (Output ON).

(The lamp of ^{OPERATE} key must be on.)

3.3.4 Zero Setup

The following explains how to set the zero output value.

You can set the output to zero in two ways:

- (1) Press the key in the POLARITY section.
- (2) Enter zero data.

Numbers ① to ④ of the figure correspond to the step numbers of the standard operation procedure.

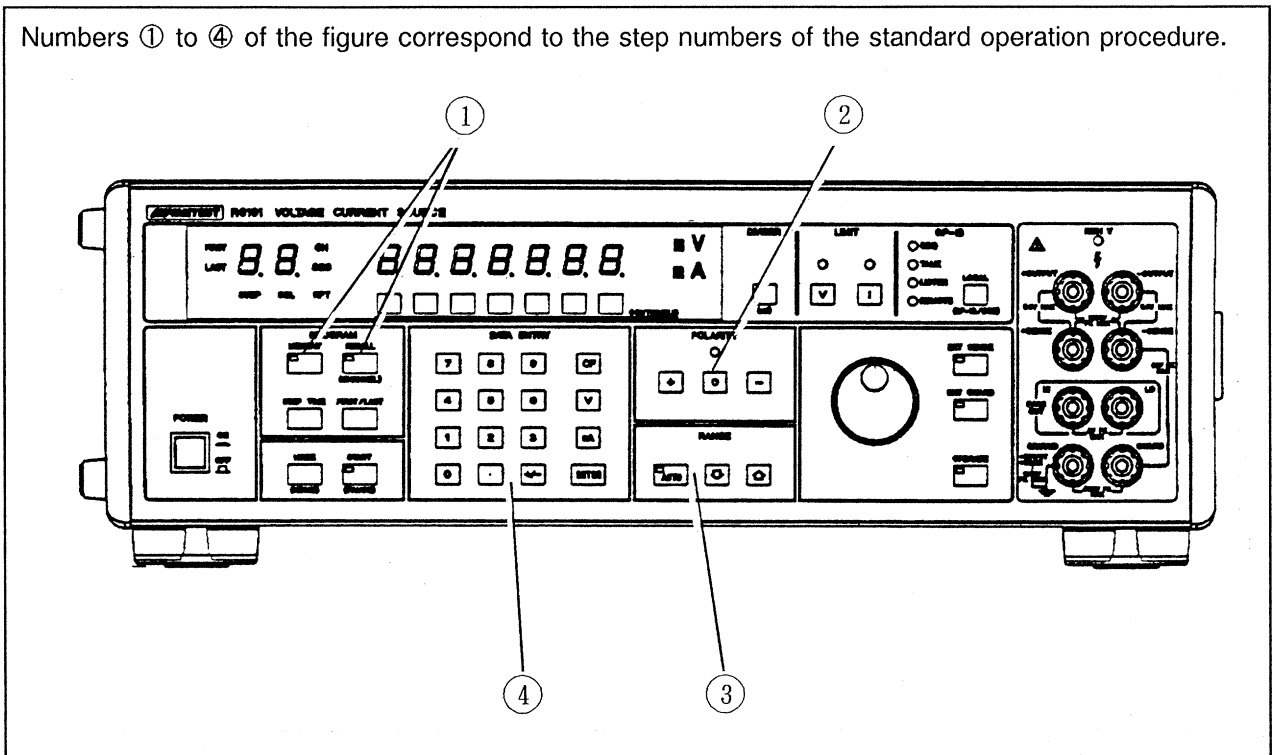

Operation procedure:

(1) When pressing the 0 key in the POLARITY section:

① Make sure that your Generator is NOT in the Memory or Recall mode.

(Both the MEMORY and RECALL lamps must be off.)

② Press the 0 key in the POLARITY section.

- Zero of the selected range will be displayed.

- To release the zero setup, press the - or + key.
(The original set value will be redisplayed.)

- * When the 0 key lamp is on, the Generator accepts the V/I limit, EXT SENSE, EXT GUARD, and DIV key input.

- * When you perform Step ②, the AUTO range is released.

(2) When entering zero data:

① Make sure that your Generator is NOT in the Memory or Recall mode.

(Both the MEMORY and RECALL lamps must be off.)

② Release the AUTO range. (The AUTO key lamp must be off.)

③ Press the 0 and ENTER keys in this sequence to set the zero data.
The zero value of the selected range will be displayed.

3.3.5 Setting the Voltage/Current Limit

Your generator can set both the voltage and current limit values regardless of the selected voltage or current mode. If you previously set the maximum voltage or current of the voltage or current generator device, the limiter of the generator can prevent any problem due to an incorrect data setup.

Numbers ① and ② of the figure correspond to the step numbers of the standard operation procedure.

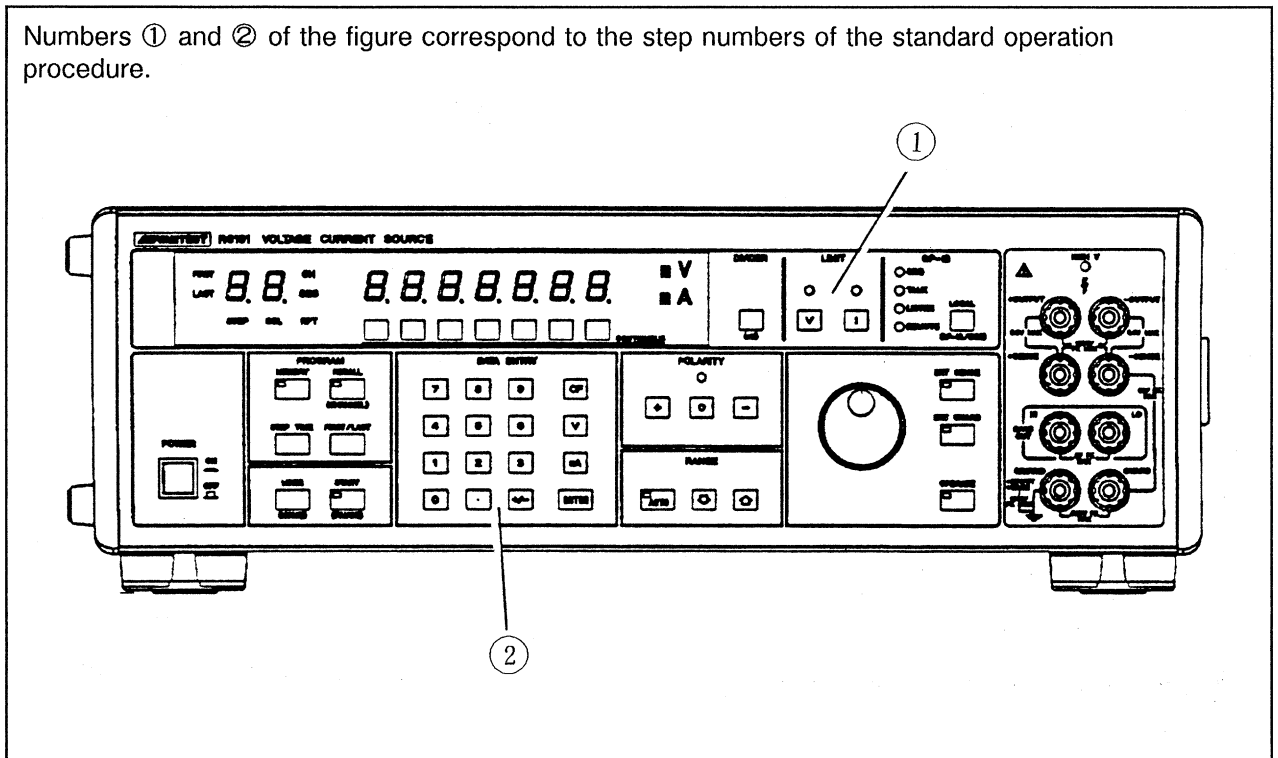

Operation procedure:

- ① Press the or key to select either the voltage limit or current limit.
- ② Set the voltage or current limit value.

Examples:

- Voltage limit: (The lamp lights.) Display : VL.1250V
(Display of previous data)
↓
 Display: 110V (The data blinks.)
 10⁰ digit
 10¹ digit
↓ 10² digit
 Display: The V limit value is set and the original output data is displayed.
- Current limit: Same as above (Display: IL.125mA)

CAUTION

1. To cancel an input, press the key.
2. The following lists the voltage/current setting range and their setting resolution.

V/I limit	Setting range	Setting resolution
V limit	10 V to 1250 V	10 V
I limit	1 mA to 125 mA	1 mA

3. No limit value can be set for the Divider function (see Table 3-5).
4. If you do not set the voltage or current limit in the Memory mode, the default of that range is set automatically.

(Cont'd)

CAUTION

Table 3-5 Voltage/current Limit Defaults of Each Range

RANGE	V limit	I limit
10 mV 100 mV 1000 mV	20 mV } 200 mV } Fixed 2 V } (No user setup is allowed.)	0.06 mA } 0.6 mA } Fixed 6.6 mA } (No user setup is allowed.) (*)
1 V 10 V 100 V 1000 V	} 130 V	} 125 mA 13 mA
1 mA 10 mA 100 mA	} 130 V	} 125 mA
1/10 mA OPT.01	130 V	13 mA

* Current that flows if the output is jumpered (During F.S output for each range)

5. The following lists the limit setting range for each RANGE.

Table 3-6 Limit Setting Range

RANGE	V limit	I limit
10 mV } 100 mV } Divider ON 1000 mV }	—	—
1 V 10 V 100 V	10 V to 130 V	1 mA to 125 mA
1000 V	10 V to 1250 V	1 mA to 13 mA
1 mA 10 mA 100 mA	10 V to 130 V	1 mA to 125 mA
Option 01 (*)	10 V to 1250 V	1 mA to 125 mA

* Option 01 has the 1200V output compliance for 1 mA/10 mA range.

6. If the limiter is activated in the 1000V range or option 01 (1mA/10mA range) is installed, the OPERATE mode is turned off.

(Cont'd)

CAUTION

7. During direct setup

To change the range from the large voltage/current limit range to the small one, the maximum voltage or current of this range is set automatically.

Example: Changing from 100V to 1000V range

VL: 120V→120V IL: 120mA→13 mA

If you reset the 1000V range back to the 100V range without setting the voltage and current limit, the original VL or IL (120 mA) value is set.

8. During direct setup

If you set a value exceeding the maximum limit, the maximum value is set for that range. However, if the set data changes to the range where the voltage limit can be set to up to 1250 V or the current limit can be set to up to 125 mA, that data is set as the limit of that range.

Example: If you set $V_L = 1200$ V in the 100V range, $V_L(\text{Maximum value}) = 130$ V that is allowed for that range is set. When changed to the 1000V range, it is set to $V_L = 1200$ V.

3.3.6 CONTINUOUS key Operations

Use the Data Control knob to change the output value. The output value be changed within the range from any of 10^0 to 10^6 digit position to the full scale.

Numbers ① to ④ of the figure correspond to the step numbers of the standard operation procedure.

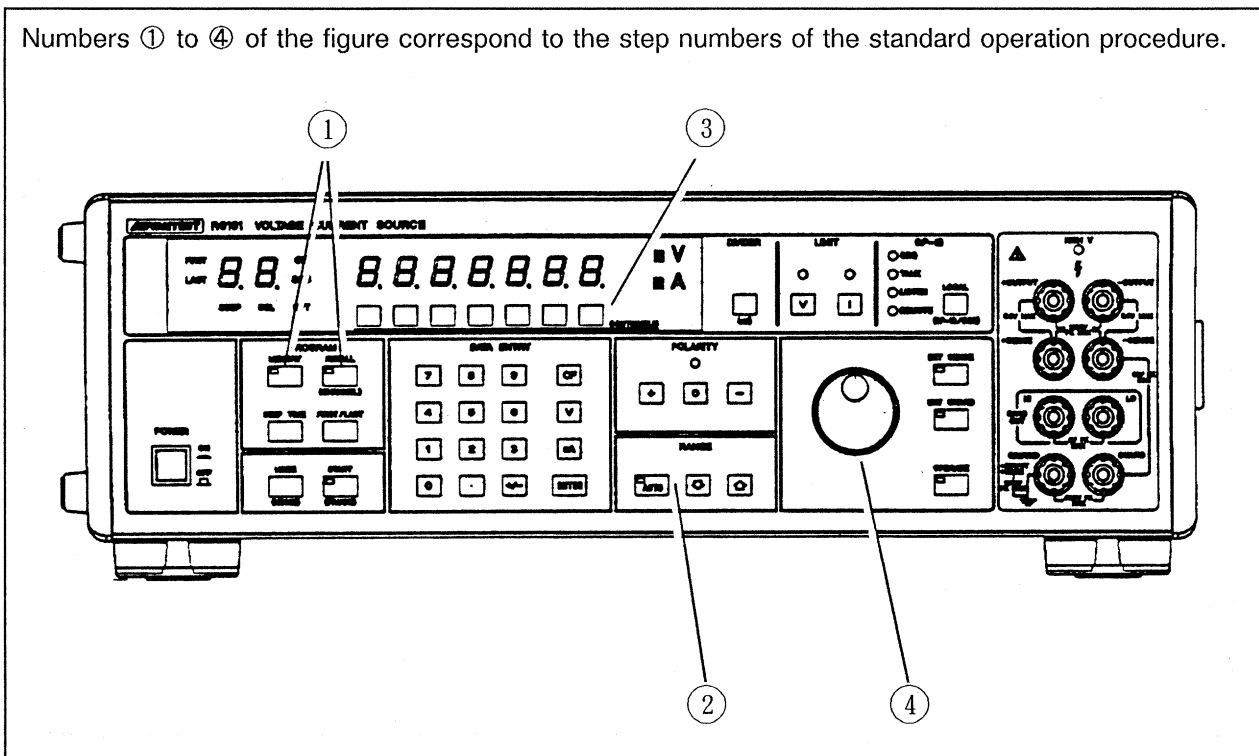

Operation procedure:

- ① Make sure that your Generator is NOT in the Memory or Recall mode.

(Both the MEMORY and RECALL lamps must be off.)

- ② Select any range (AUTO or MANUAL).

- ③ Press any desired CONTINUOUS key (10^0 to 10^6 digit keys).

(The pressed key value will blink.)

- To release your entry, press the CONTINUOUS key again.
- To change your entry, press any other CONTINUOUS key.

- ④ Increase or decrease the value from the blinking value position by using the Data Control knob.

Rotate clockwise (CW):

Increases the value from the blinking value position to the full scale.

Rotate counterclockwise (CCW):

Decreases the value from the blinking value position to zero at all high-order digits.

CAUTION

If the AUTO range has been set, an appropriate range (having the maximum effective digits) is selected. (The setting resolution is always fixed.)

1.

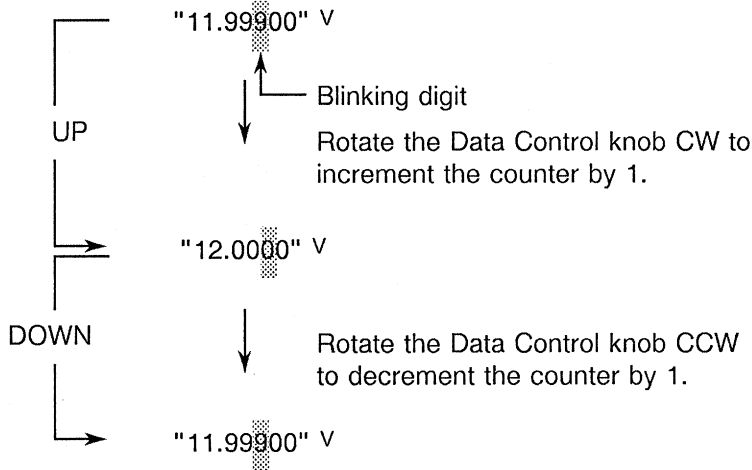

2. If the CONTINUOUS key blinking point is at 10^6 digit, no Range Down is allowed.

Example:

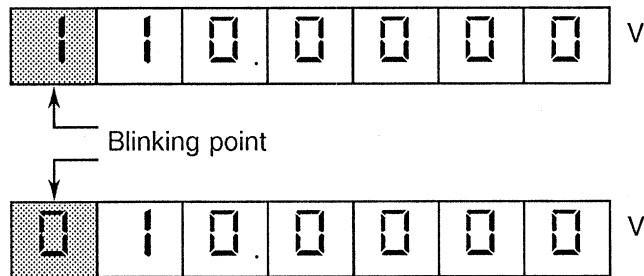

(The 100V range is held without Range Down.)

3. If the CONTINUOUS key blinking point is at 10^0 digit, no Range Up (Auto range option) is allowed to hold the fixed setting resolution.

4. In the CONTINUOUS mode, you can check the voltage or current limit value and set the polarity

(by pressing the 0 + - key of POLARITY section).

3.3.7 Changing the Function Keys

The Generator provides three functions for voltage generation, current generation, and Divider voltage generation. Select one of them using the DATA ENTRY block keys and key.

Operation procedure:

(1) Changing the function during direct operation:

① To change from V function to I function

keys: Selects the minimum current range (1mA).

keys: Selects the 10mA current range and the 10mA data is set.

② To change from I function to V function

keys: Selects the minimum voltage range (1V).

keys: Selects the 10V voltage range and the 10V data is set.

③ To change from V/I function to Divider function

keys: Selects the 1V range.



key: Selects the 1000mV Divider range.
(When you press this key again, the 1V range is selected.)

④ To change from Divider function to V function

keys: Selects the 1V range of V function.
(When you press this key again, the 1000mV (DIV) range is selected.)

- ⑤ To change from Divider function to I function

DIV keys: Selects the 1V range of V function.
↓

0 **mA** **ENTER** keys: Selects the minimum current range (1mA).

CAUTION

Turn the OPERATE mode to OFF before function switching.

- (2) Changing the function during memory setup:

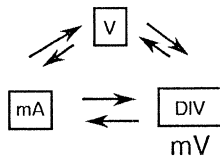

- ① The change between **V** and **mA** mode is the same as those of the direct operation.

- ② **DIV** **mA** **DIV** **V**
mV mV mV
↔ ↔ ↔
↔ ↔ ↔
- The **DIV** key functions as "mV" in the Memory Setup mode. It can be used in the same way as the "mA" or "V" key. That is, the operation is the same as Paragraph ①.

Examples:

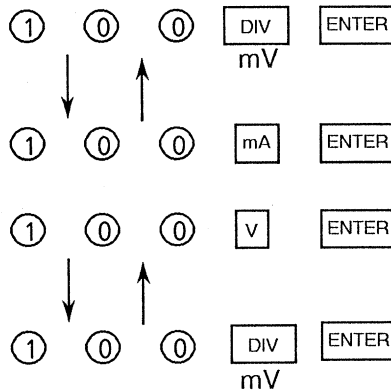



3.3.8 Changing the Generation Range

Table 3-7 summarizes the signal generation range and its resolution for each RANGE.

Table 3-7 Signal Generation Range

Function	RANGE	Signal generation range	Setting resolution
Voltage generation	DEVIDER	10 mV 100 mV 1000 mV	00.00000 to 11.99999 mV 000.0000 to 119.9999 mV 0000.000 to 1199.999 mV
		1 V 10 V 100 V 1000 V	0.000000 to 1.199999 V 00.00000 to 11.99999 V 000.0000 to 119.9999 V 0000.000 to 1199.999 V
Current generation		1 mA 10 mA 100 mA	0.000000 to 1.199999 mA 00.00000 to 11.99999 mA 000.0000 to 119.9999 mA
			1 nA 10 nA 100 nA

Operation procedure:

Use the  or  key to change the range.
DOWN UP

CAUTION

1. If the range is changed, the generation value is increased by 10 times (Up) or decreased by 10 times (Down).
2. The OPERATE is turned off if 1000V range is set.
3. If option 01 (with 1200V output compliance for 1mA or 10mA) is installed, the OPERATE is turned off in the 1mA or 10mA range.

3.3.9 Changing the Polarity

You can change the polarity in two ways:

- (1) Press the + or - key of the POLARITY section.
- (2) Press the +/- key of the DATA ENTRY key section.

Numbers ① and ② of the figure correspond to the step numbers of the standard operation procedure.

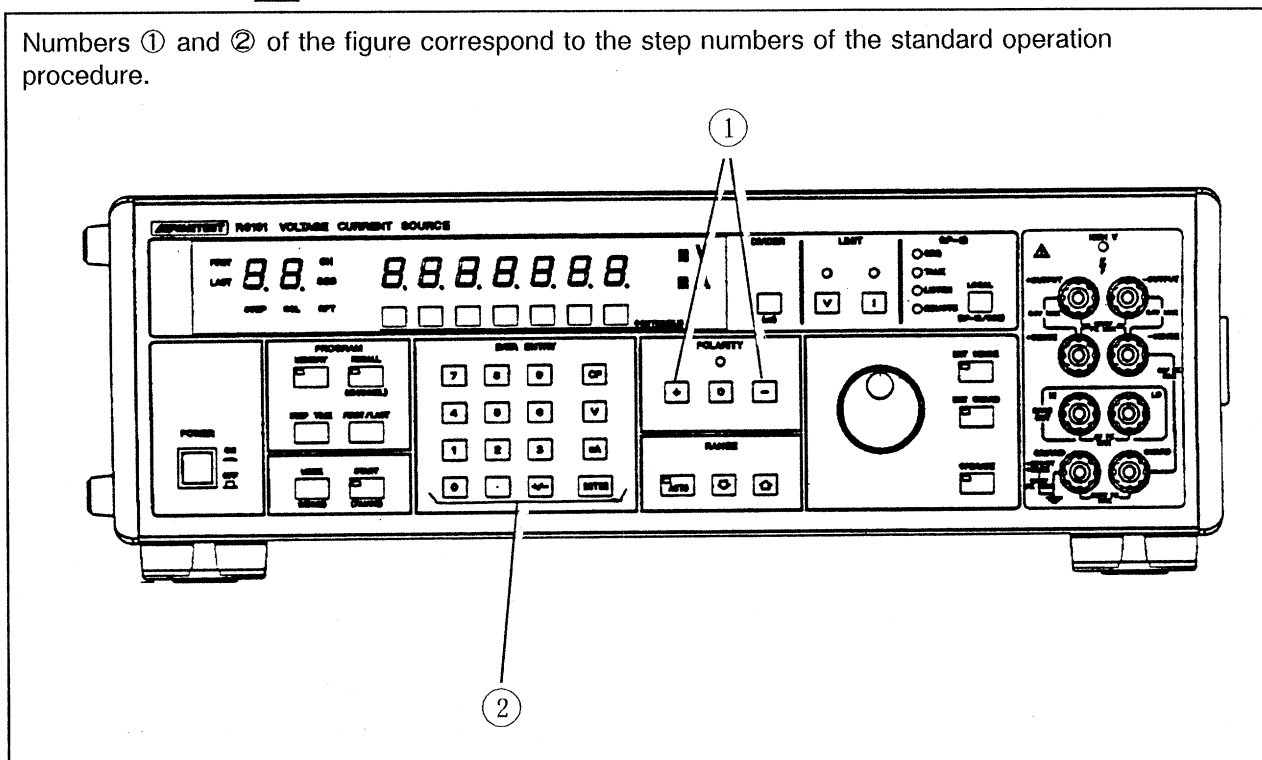

Operation procedure:

- (1) When pressing the + or - key of the POLARITY section:
Press the + or - key to change the polarity of the output.
- (2) When pressing the +/- key of the DATA ENTRY key section:
Press the +/- key, enter data, and press the ENTER key.

The polarity of the output will be changed.

CAUTION

If you change the polarity (using the + or - key), the output is once turned off (Zero output status).

3.3.10 Restrictions on Limit Setup

RESTRICTIONS

1. Different channel of the same range is restricted to access in the Recall mode.
2. Direct data setup in the same range is restricted via the GPIB interface.

If you set the voltage limit of value B below value A when changing the output from value A (large value) to value B (small value), the limit function operates during response of the output value (that is, during the time when the value changes from value A to value B).

Example: The following shows the output waveforms during access when channel 0 (100V range, 100V output, $V_L = 130$ V) is changed to channel 1 (100V range, 20V output, $V_L = 60$ V).

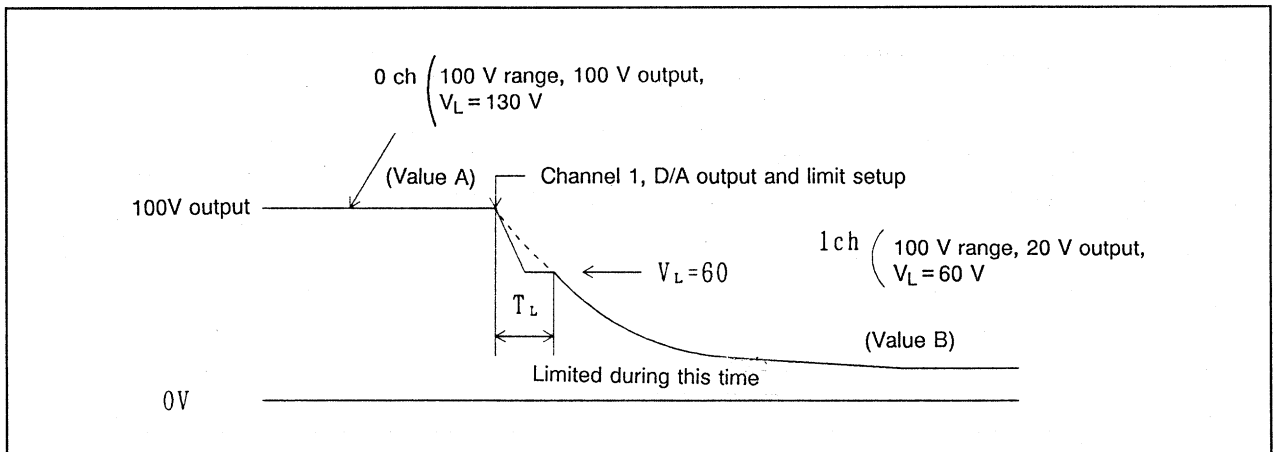

The limit value is set at the same time when the D/A output is changed (from 100V to 20V). The limit time of " T_L " shown above is required.

CAUTION

For the 1000V range or 1mA or 10mA range of option 01, the output is turned off if limited. You must turn it ON (for OPERATE) again.
To avoid repeated switching of output to ON, set the limit value greater than the previous output value of the voltage limit.

3.3.11 Output Generation (1000V/100V range) and Current Limit Detection

When you have selected the 1000V range and set the current limit to the minimum level and when you generate the voltage signal, the Generator limits the current by using the charge current to the 0.6 μ F capacitor locating between the internal output terminals.

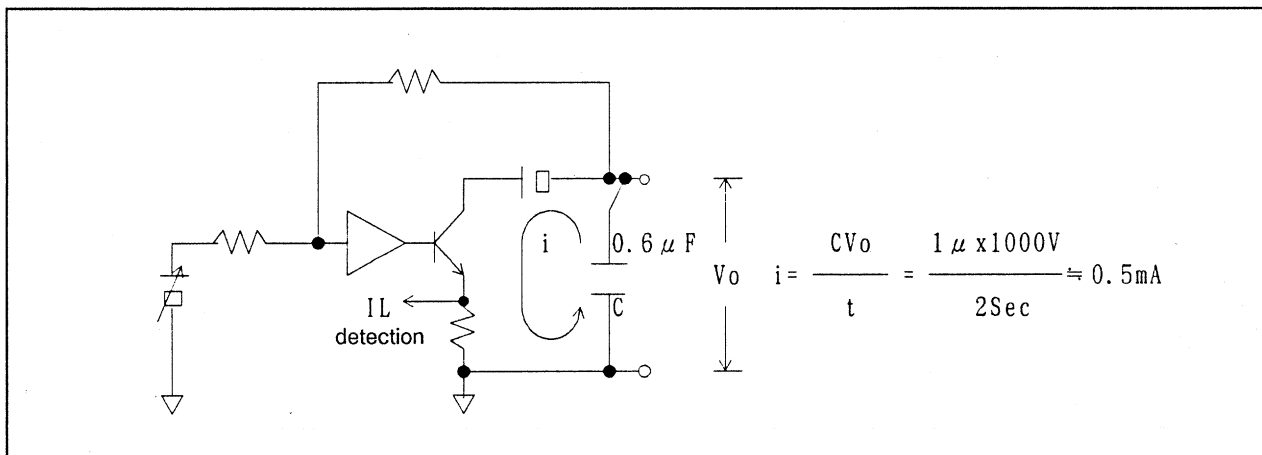

In the 1000V range, the output is turned off (set to Standby mode) when limited. During the time (approximately 2 seconds) until the charge current reaches below 1 mA, the current limit is ignored.

If 0V is changed to "F.S" or "F.S" is changed to 0V in the 100V range (where the large voltage variation occurs), the current is limited instantaneously. To avoid such problem, set the current limit above 3 mA.

CAUTION

The 2-second delay time for current limit detection is the time after the output value setup. If a limit occurs due to load variation in the normal status, the output is turned off (and set to standby mode) immediately.

3.4 Output Operation Timing

3.4.1 Timing when the Set Data is Changed

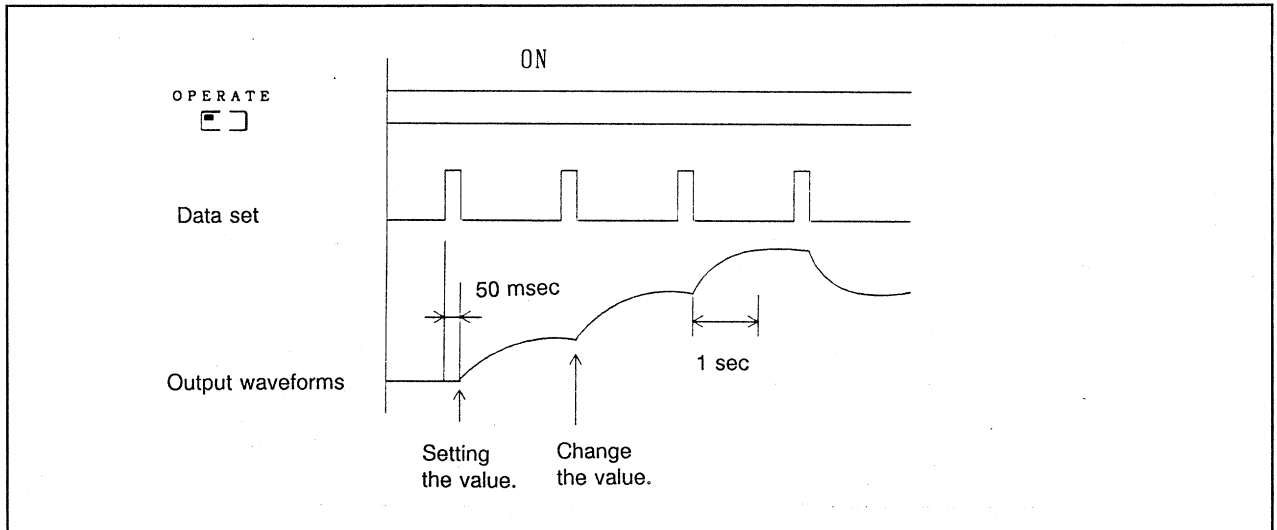

3.4.2 Timing when Output is Turned on (Operate) or Off (Standby)

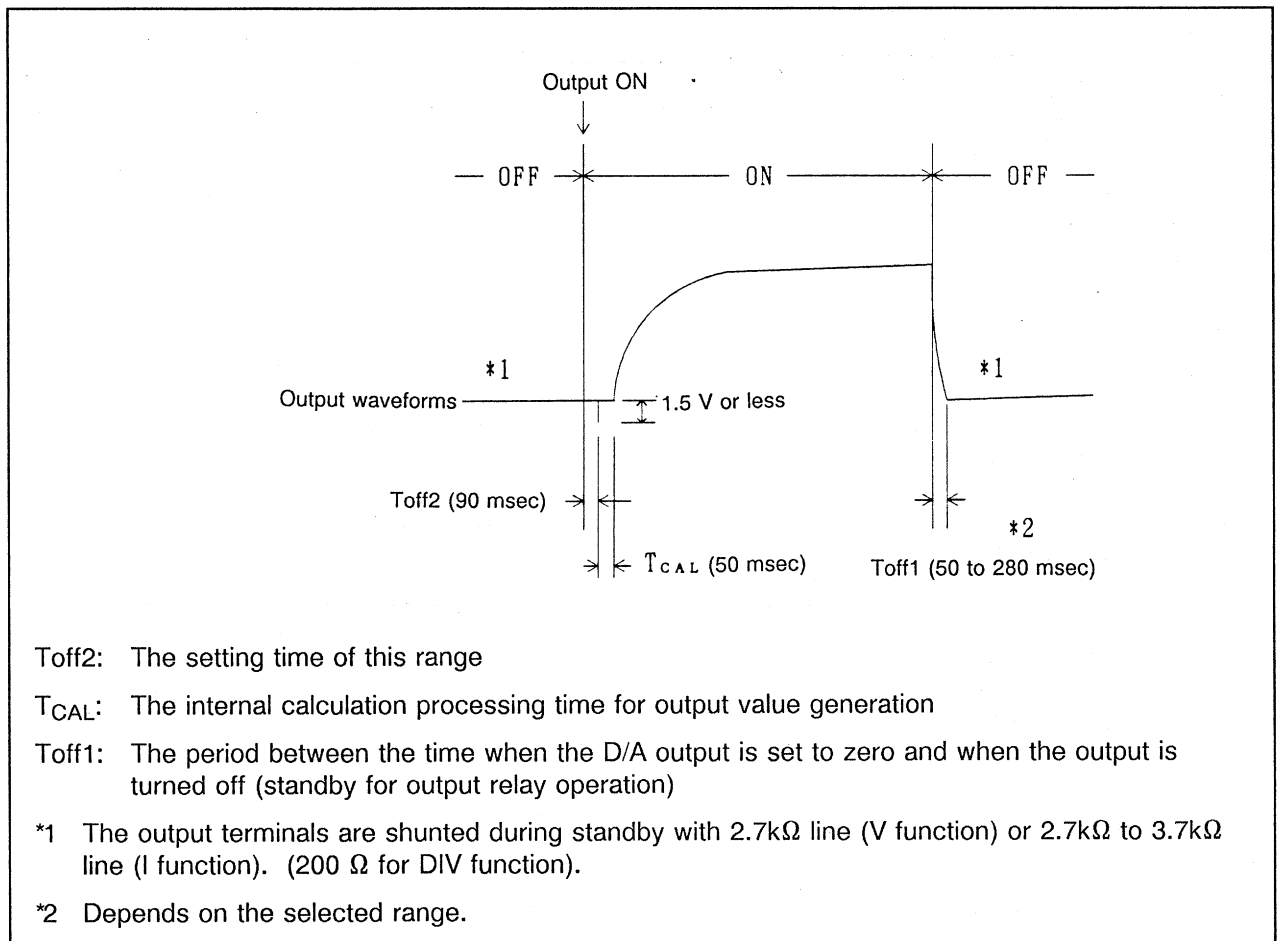

3.4.3 Timing when the Range is Changed

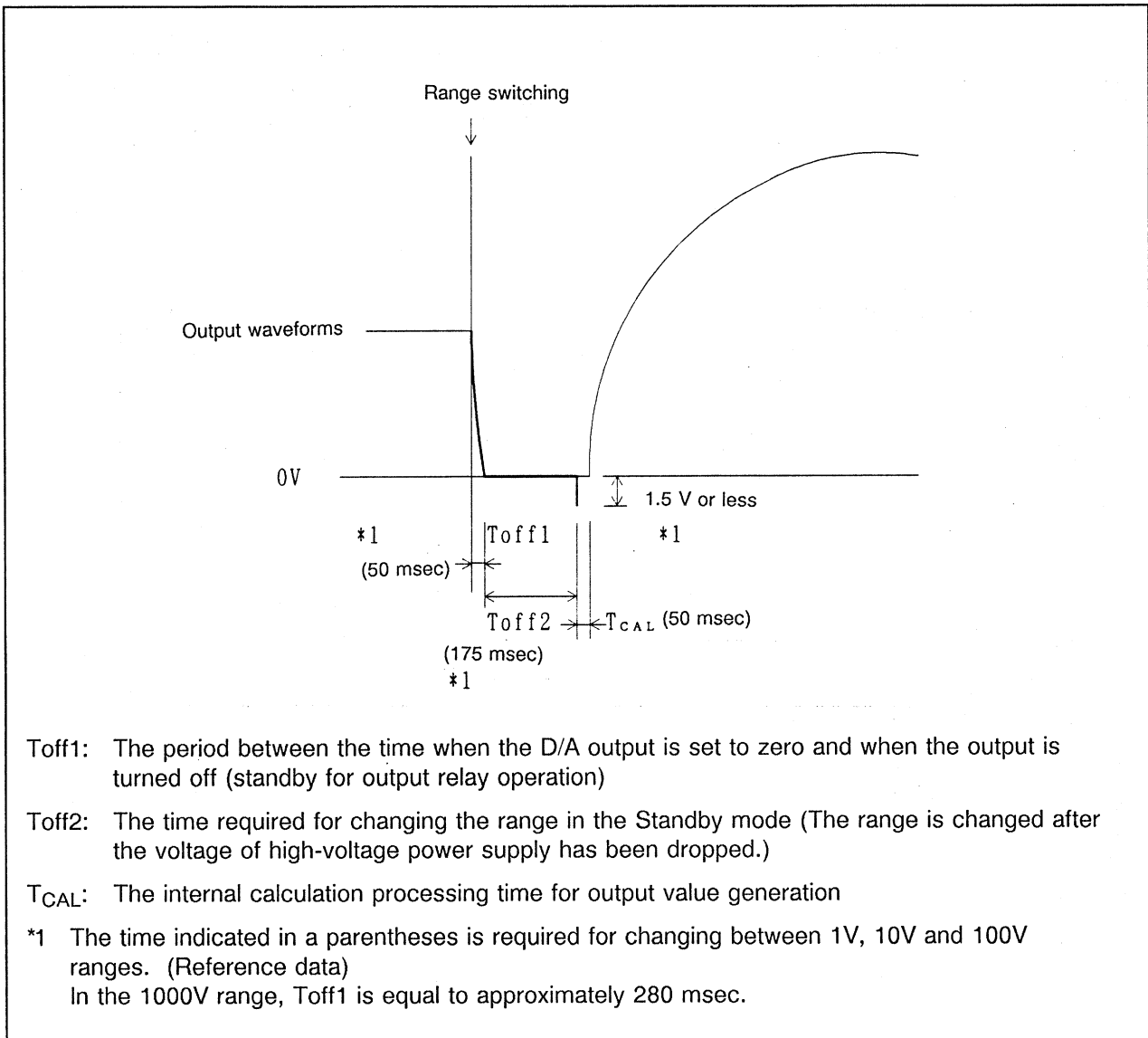

3.4.4 Timing when the Functions are Changed

CAUTION

If you change the function (between V and I, between V and DIV, and between I and DIV) in the Manual mode, the output is turned off (standby). However, in the Recall mode, the output is kept on (operate status) even when the function is switched.

Example: When function is switched between V and I:

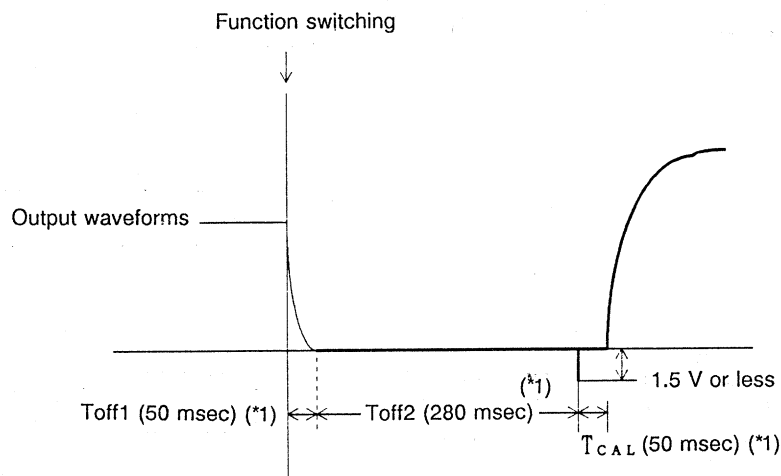

T_{off1} : The period of time when the D/A output is set to zero and when the output is turned off (standby status for output relay operation). (T_{off1} is approximately 280 msec in the 1000V range or in the 1mA or 10mA range of option 01.)

T_{off2} : The range switching time in the Standby mode. (It is switched after the voltage of high-voltage power supply has been dropped.)

T_{CAL} : The internal calculation processing time for output value generation

*1 The time indicated in a parentheses is the reference data.

3.4.5 Timing when the Polarity is Changed

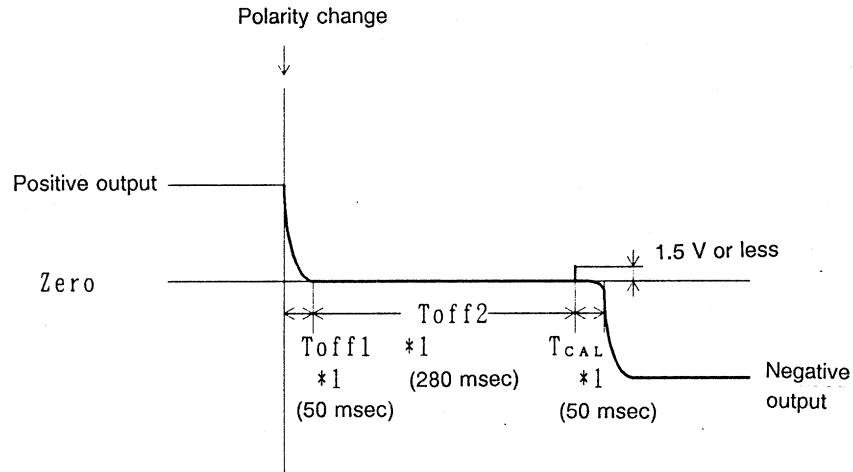

T_{off1} : The period of time when the D/A output is set to zero and when the output is turned off (standby status). (T_{off1} is approximately 280 msec in the 1000V range or in the 1mA or 10mA range of option 01.)

T_{off2} : The polarity switching time in the Standby mode. (It is switched after the voltage of high-voltage power supply has been dropped.)

T_{CAL} : The internal calculation processing time for output value generation

*1 The time indicated in a parentheses is the reference data.

3.4.6 Operate/Standby, Range, Function and Polarity Switching Time

- (1) Output generation time when Standby status is changed to Operate status

Table 3-8 Time Required for Output Generation when Standby Status is Changed to Operate Status

Function	RANGE	Output time ($T_{off2} + T_{CAL}$) (*)
V	1, 10, 100 V	Approximately 140 msec
	1000 V	
DIV	10 mV	
	100 mV	
	1000 mV	
I	1, 10, 100 mA	
	1mA or 10 mA of option 01 (with 1200 V output compliance)	

* See Section 3.4.2.

- (2) Output generation time when the range is changed

Table 3-9 Output Generation Time when the Range is Changed

Function	Change of range	Output time ($T_{off1} + T_{off2} + T_{CAL}$) (*)
V	Between 1 V, 10 V and 100 V ranges	Approximately 275 msec
	From 1 V, 10 V or 100 V range to 1000 V range	Approximately 335 msec
	From 1000 V range to 1 V, 10 V or 100 V range	Approximately 555 msec
DIV	Between 10 mV, 100 mV and 1000 mV ranges	Approximately 275 msec
I	Between 1 mA, 10 mA and 100 mA ranges	Approximately 275 msec
	Between 1 mA and 10 mA ranges of option 01	Approximately 650 msec
	Between 1 mA or 10 mA of option 01 and 100 mA range	Approximately 535 msec

* See Section 3.4.3.

CAUTION

When the 1000V range or 1mA or 10mA range of option 01 is selected, the output is turned off (standby status). However, in the Recall mode, the previous output is kept.

(3) Output generation time when the function is changed

Table 3-10 Output Generation Time when Function is Changed

Change of function		Output time ($T_{off1} + T_{off2} + T_{CAL}$) (*)
Between V and I functions	Between 1 V, 10 V or 100 V range and 1 mA, 10 mA or 100 mA range	Approximately 370 msec
	From 1000 V range to 1 mA, 10 mA or 100 mA range	Approximately 650 msec
	From 1 mA, 10 mA or 100 mA range to 1000 V range	Approximately 335 msec
	Between 1000 V range and 1 mA or 10 mA range of option 01	Approximately 650 msec
Between V and DIV functions	From 1 V, 10 V or 100 V range to 10 mV, 100 mV or 1000 mV range.	Approximately 305 msec
	From 10 mV, 100mV or 1000 mV range to 1 V, 10 V or 100 V range.	Approximately 340 msec
	From 1000 V range to 10 mV, 100 mV or 1000 mV range	Approximately 615 msec
	From 10 mV, 100 mV or 1000 mV range to 1000 V range	Approximately 335 msec
Between I and DIV functions	Between 1 mA, 10 mA or 100 mA range and 10 mV, 100 mV or 1000 mV range	Approximately 335 msec
	From 1 mA or 10 mA range of option 01 to 10 V, 100 V or 1000 V range	Approximately 615 msec
	From 10 mV, 100 mV or 1000 mV range to 1 mA or 10 mA range of option 01	Approximately 335 msec

* See Section 3.4.4.

CAUTION

When the function is changed, the output is turned off (standby status) except in the Recall mode.

(4) Output generation time during polarity change

Table 3-11 Output Generation Time during Polarity Change

Function	RANGE	Output time (T _{off1} + T _{off2} + T _{CAL}) (*)
V	1, 10, 100 V	Approximately 375 msec
	1000 V	Approximately 650 msec
DIV	10, 100, 1000 mV	Approximately 370 msec
I	1, 10, 100 mA	Approximately 310 msec
	1 mA or 10 mA range of option 01	Approximately 650 msec

* See Section 3.4.5.

3.5 Setup and Usage of Program Functions

CAUTION

Cautions on Step Time and First/Last Channel programs:

1. When the Memory mode is selected, the output is forcibly set to the Standby mode (no operation is allowed).
2. Up to two digits of data can be entered.
3. To cancel an incorrect entry, press the key.
4. To release the STEP TIME or FIRST/LAST channels setup, press the key.

3.5.1 Step Time

The Step Time is the scanning time in the Single or Repeat Scan mode. It can be from 1 second to 99 seconds.

Setup procedure:

- ① Press the key to select the Memory mode.

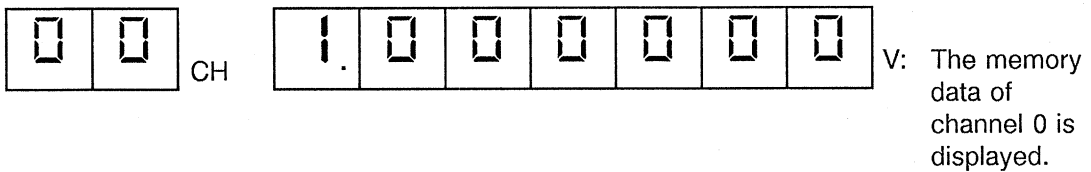

- ② Press the key, and the already specified value will be displayed.

Example:

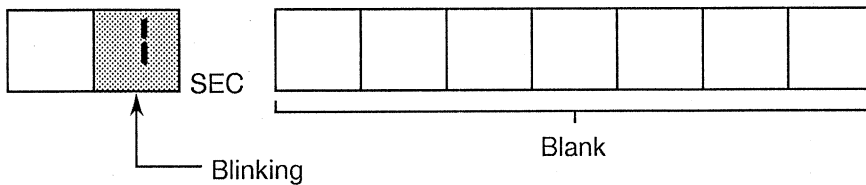

- ③ Enter data (an example of 10 seconds).

Example: Input of 10 seconds.

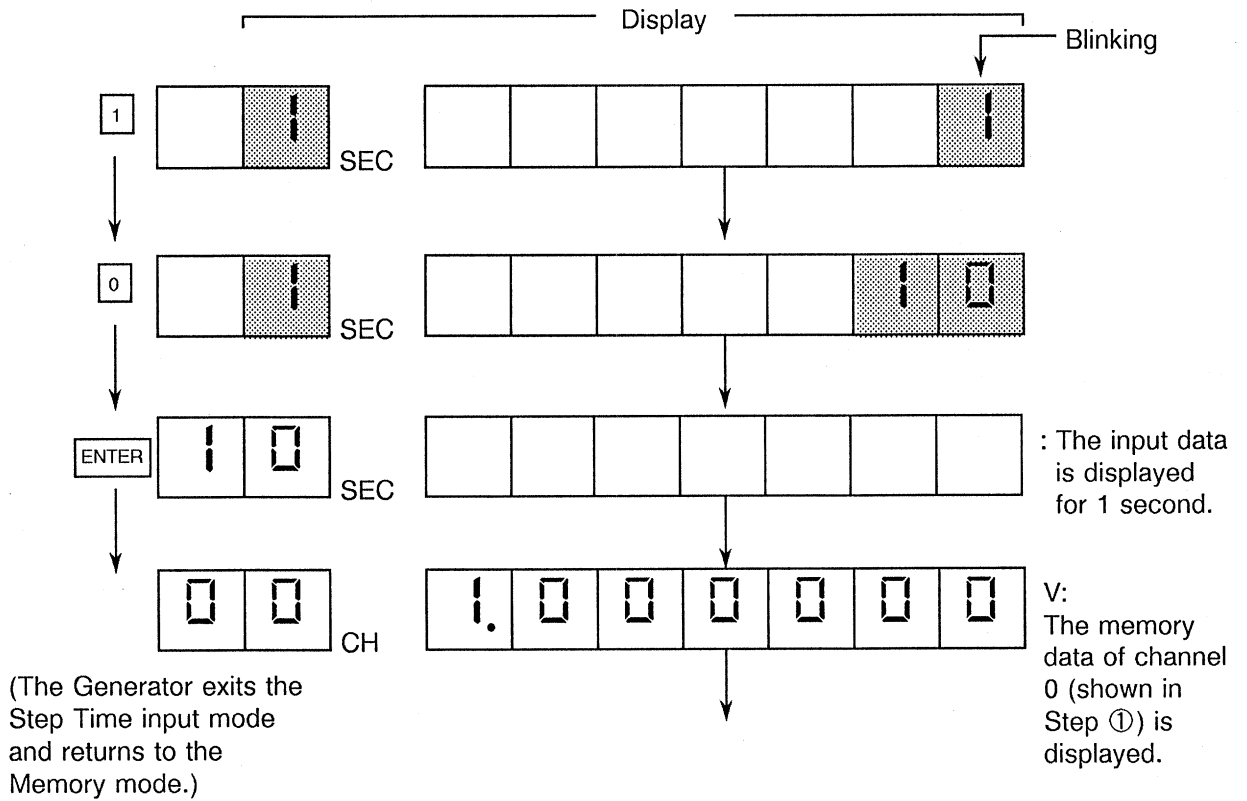

3.5.2 First/Last Channel

You can set the output start (first) channel and end (last) channel in the Step, Single, or Repeat Scan mode. It can be from 00 to 99 channels.

Setup procedure:

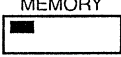
- ① Press the  key to select the Memory mode.

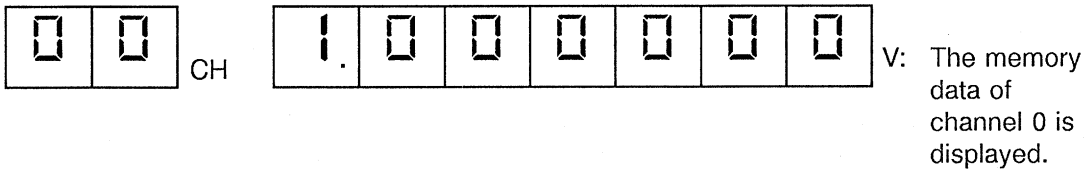

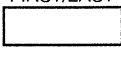
- ② Press the  key.
- for FIRST: The already specified first channel data will be displayed.
 for LAST: The already specified last channel data will be displayed.

Example:

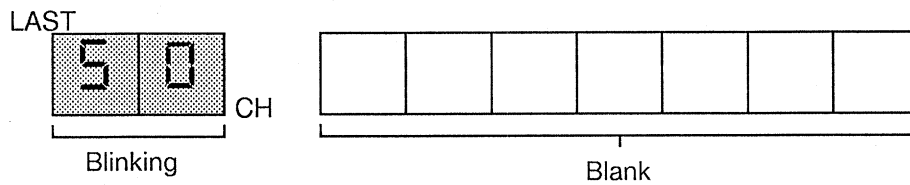
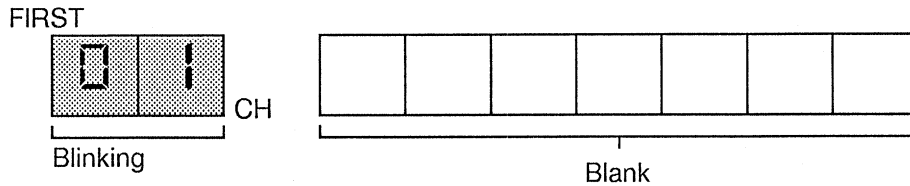

- ③ Enter data (an example of channel 10 as the first channel).

Example: Input of channel 10.

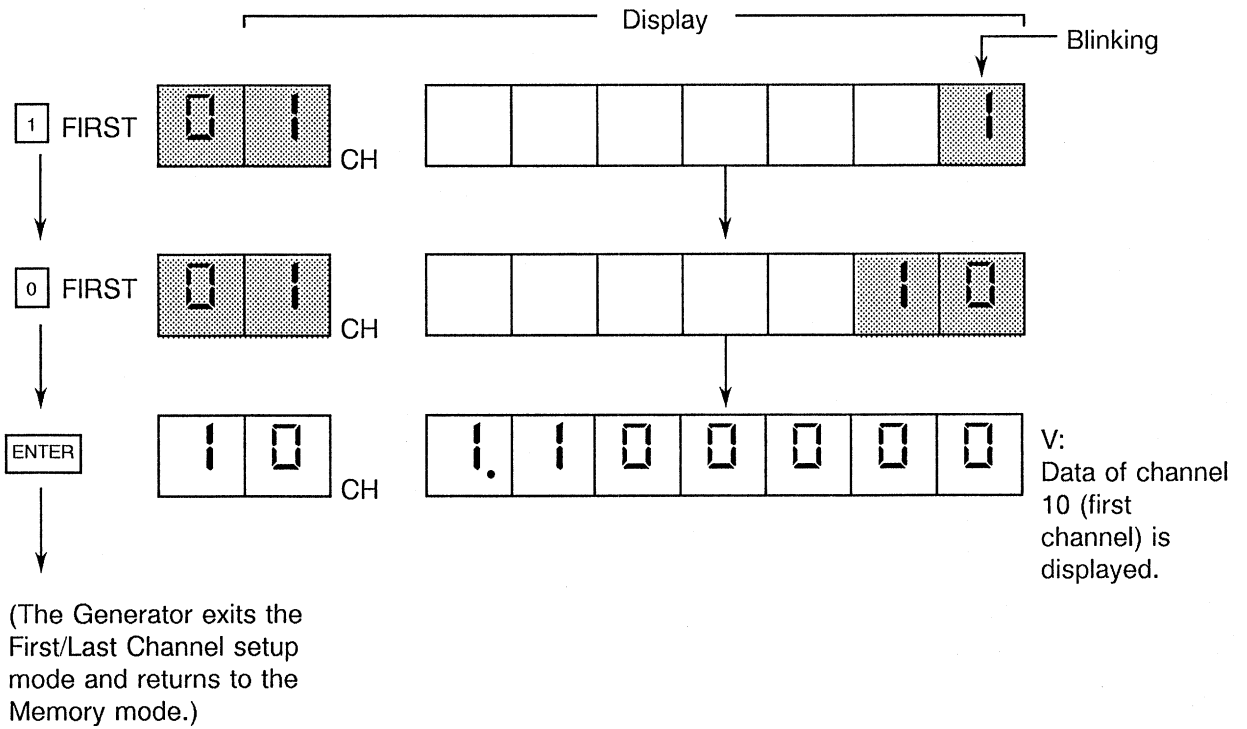

- ④ Set the last channel of data (an example of channel 71 as the last channel).

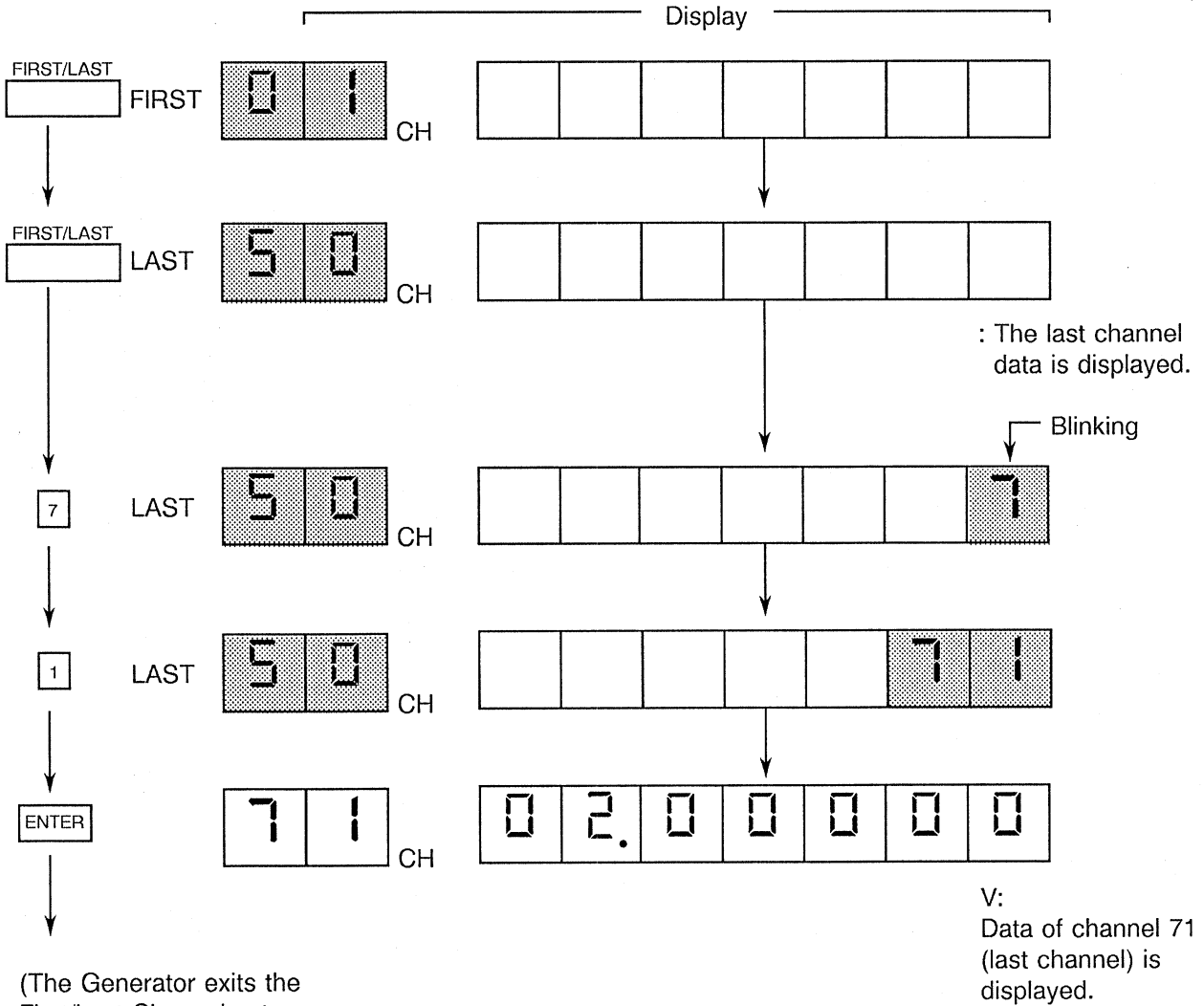

(The Generator exits the First/Last Channel setup mode and returns to the Memory mode.)

3.5.3 Memory Setup and Recall of Generation Data

CAUTION

Cautions on programming of generation data and V/I limit:

1. The manual range is selected in the Memory setup mode. (That is, when you select the Memory mode, the Auto Range is released.)
2. To change the function to the Divider, enter data and press the ○○○ ,
(Data) (mV)
and keys in this sequence. (The key functions same as "V" or "mA".)
3. Use the key to select the range data to be stored in memory.
4. The default voltage/current limit is set when you press the key for the output data or when you change the range.
(See Table 3-5 for defaults of each range. If the voltage/current limit setup is required, enter the desired voltage or current after you have entered the output data.)
5. When you select the Memory mode, the output is forcibly turned off (standby status). No operation is allowed.
6. To cancel an incorrect entry, press the key.
7. To increment the channel number, repeat pressing the key.
8. For random access to a channel, enter the channel data and press the key.
(CHANNEL)

(1) Memory store of generation value

The following data can be stored in 100 channels of memory area.

- Built-in memory areas: 0 to 99 channels
- Setting data: V, I, V_Divider, V/I limit data

Setup procedure:

Example: To store the following data in channel 12:

- Output voltage: 10.2 V
- Voltage limit (V_L): 20 V
- Current limit (I_L): 20 mA

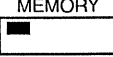
- ① Press the  key to select the Memory mode.

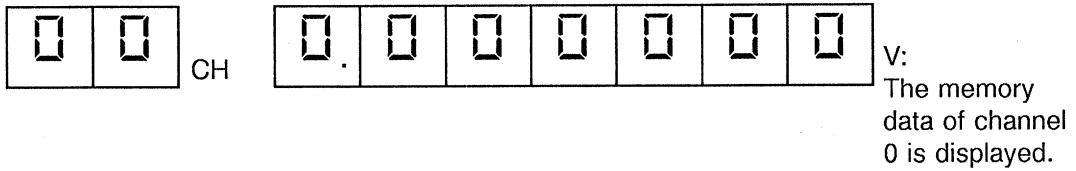

Call channel 12.

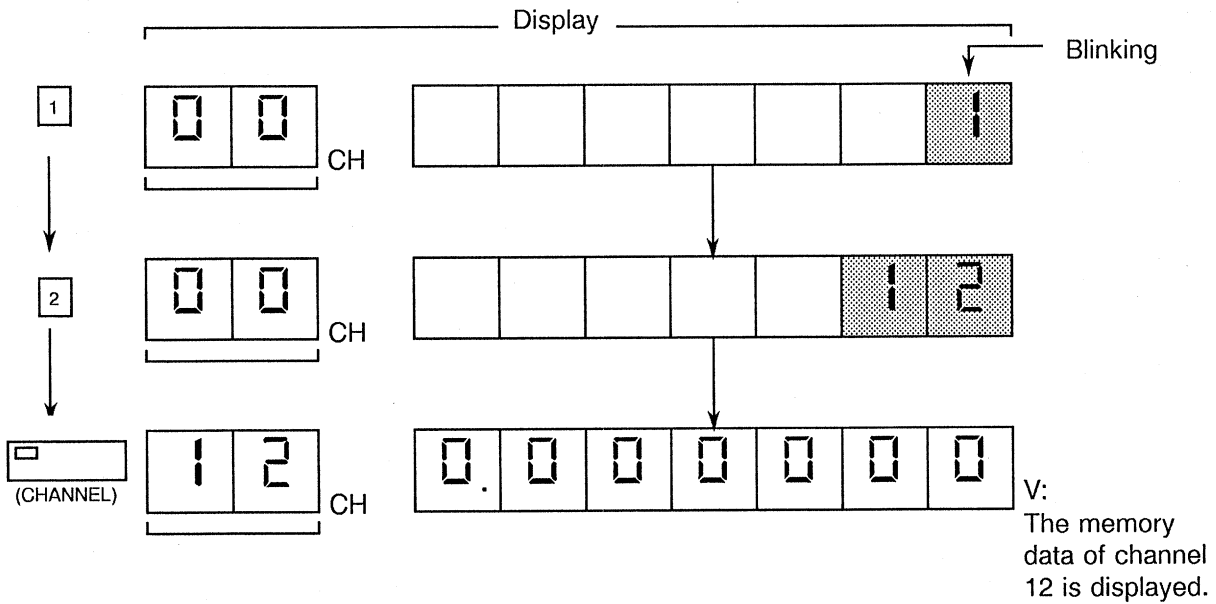

- ② Specify any desired data for this channel.

a) Press the key to select the 10V range (from the 1V range).

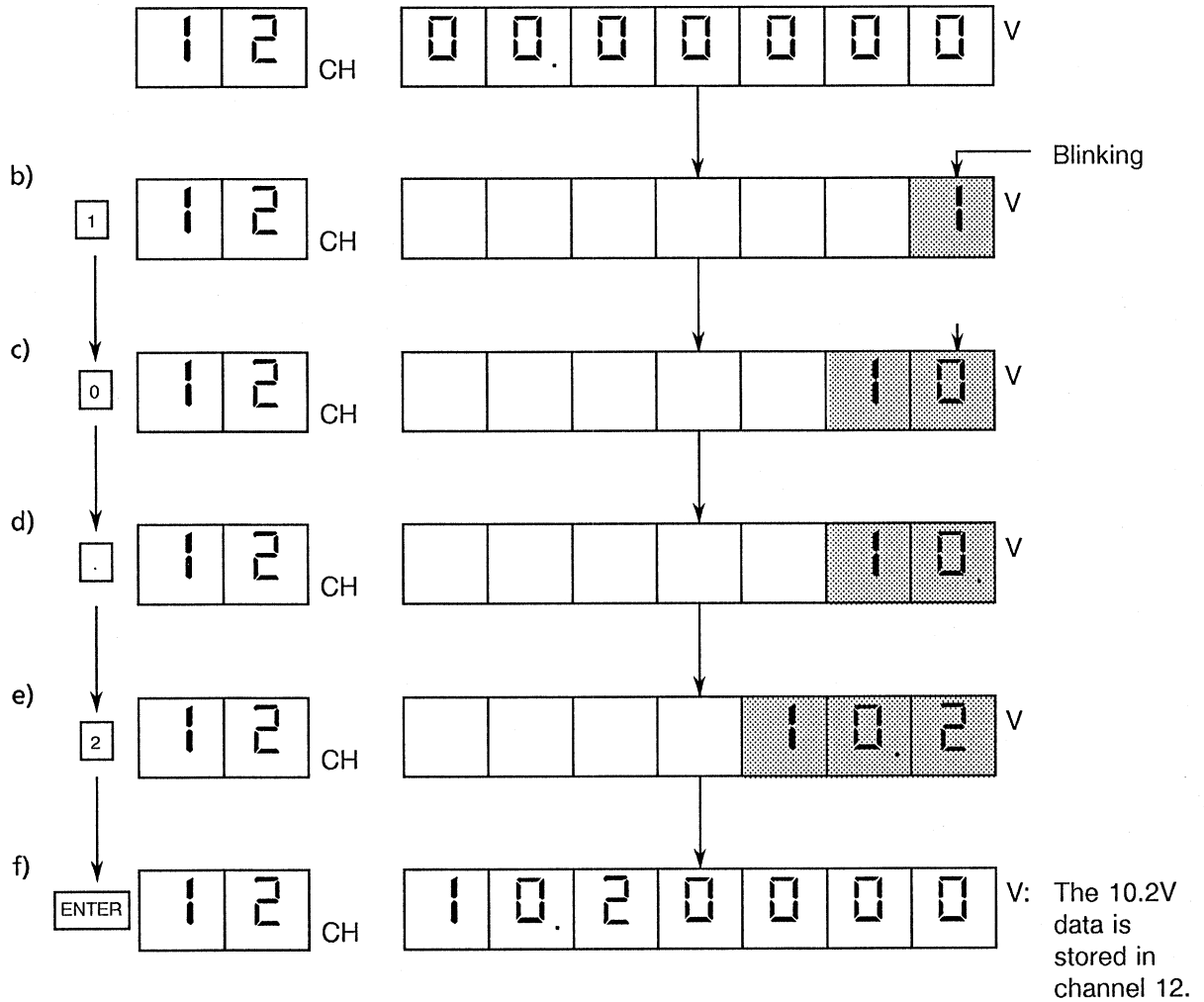



* In Substep a), the memory data is set to "00.00000 V". The default V and I limit values are set automatically.

* When you press the key again, the memory data of channel 13 is displayed.

- Specify the voltage/current limit for channel 12.

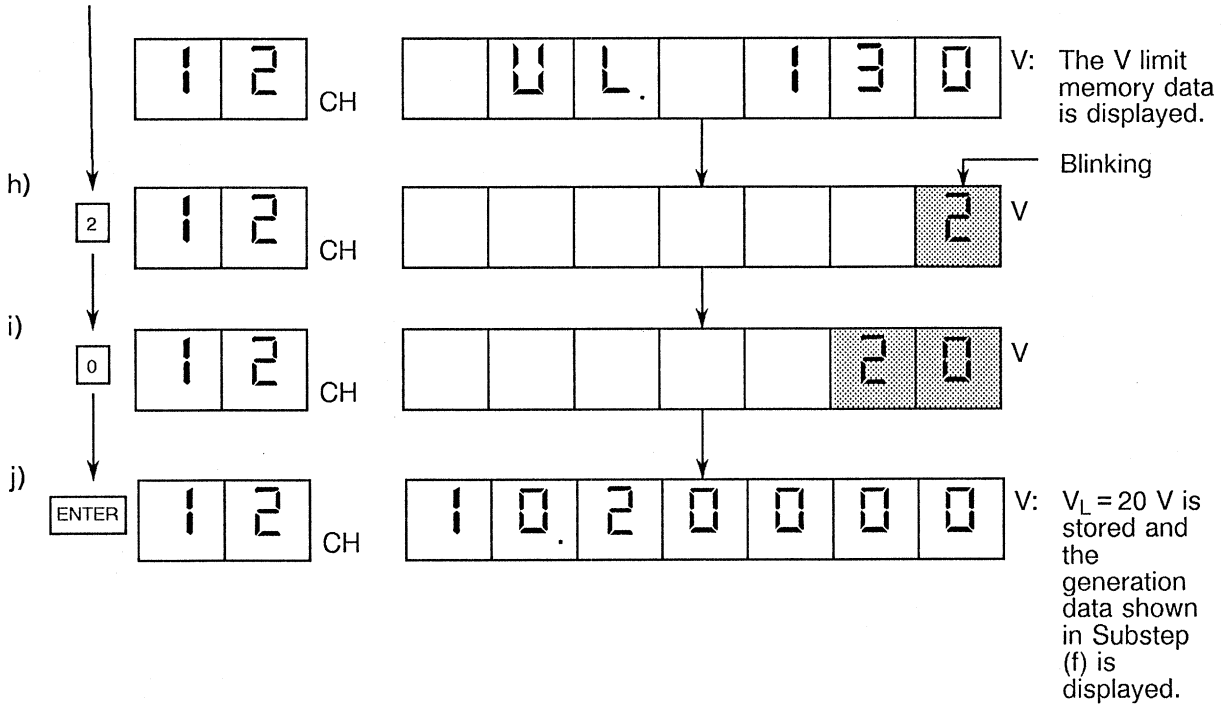
g) Press the  key to select the V limit setup mode.



k) Press the  key to select the I limit setup mode.

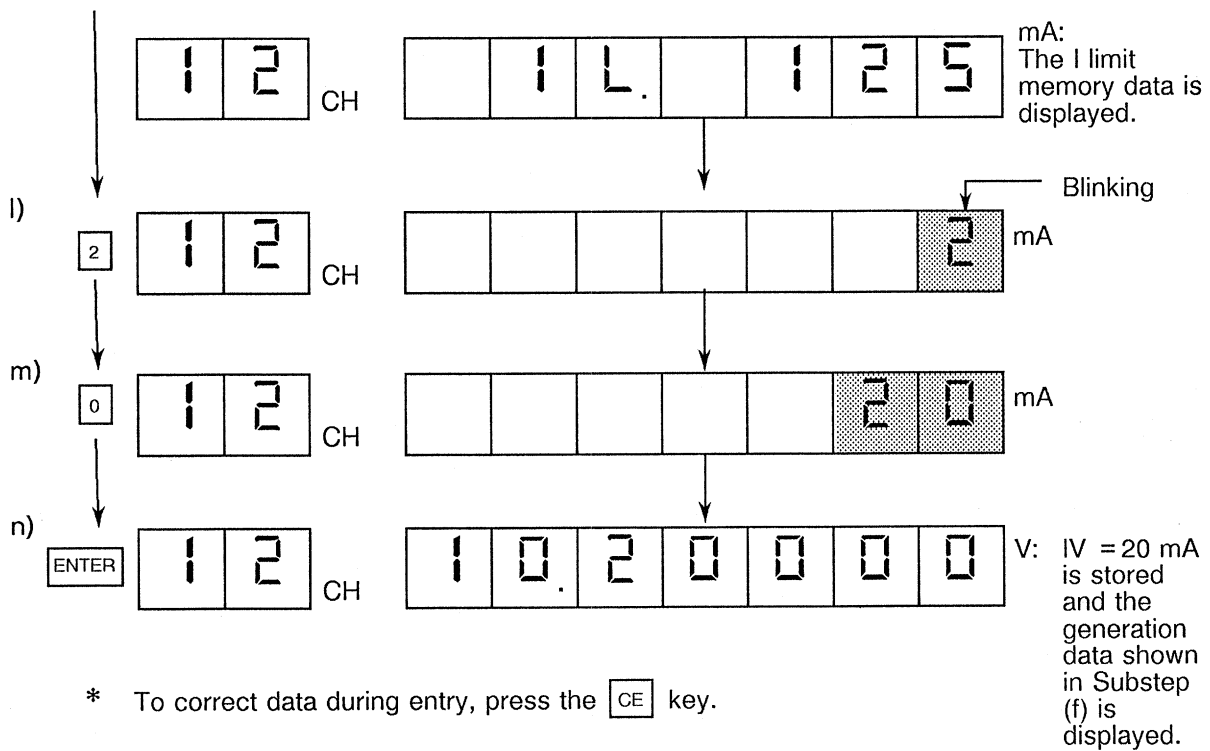

* To correct data during entry, press the  key.

(2) How to recall memory data

To recall data from memory, use one of the following four modes:

- Direct Channel Access
- Step
- Single Scan
- Repeat Scan

Direct Channel Access mode:

Any channel data can be recalled directly.

Operation procedure:

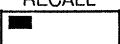
- ① Press the  key to select the Recall mode.

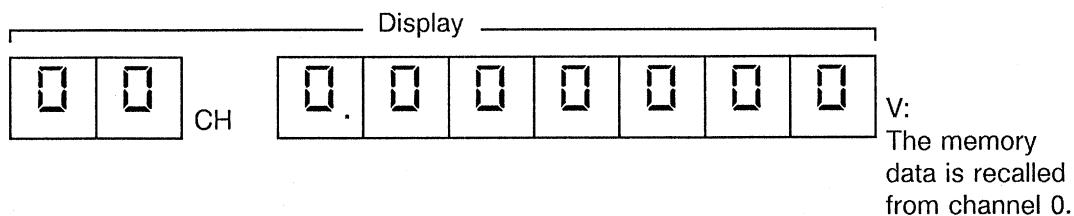

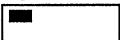
* If you press the  key, "0 V" is output.

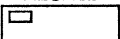
* To release the Recall mode, press the  key again.

- ② Recall data from channel 99 (example).

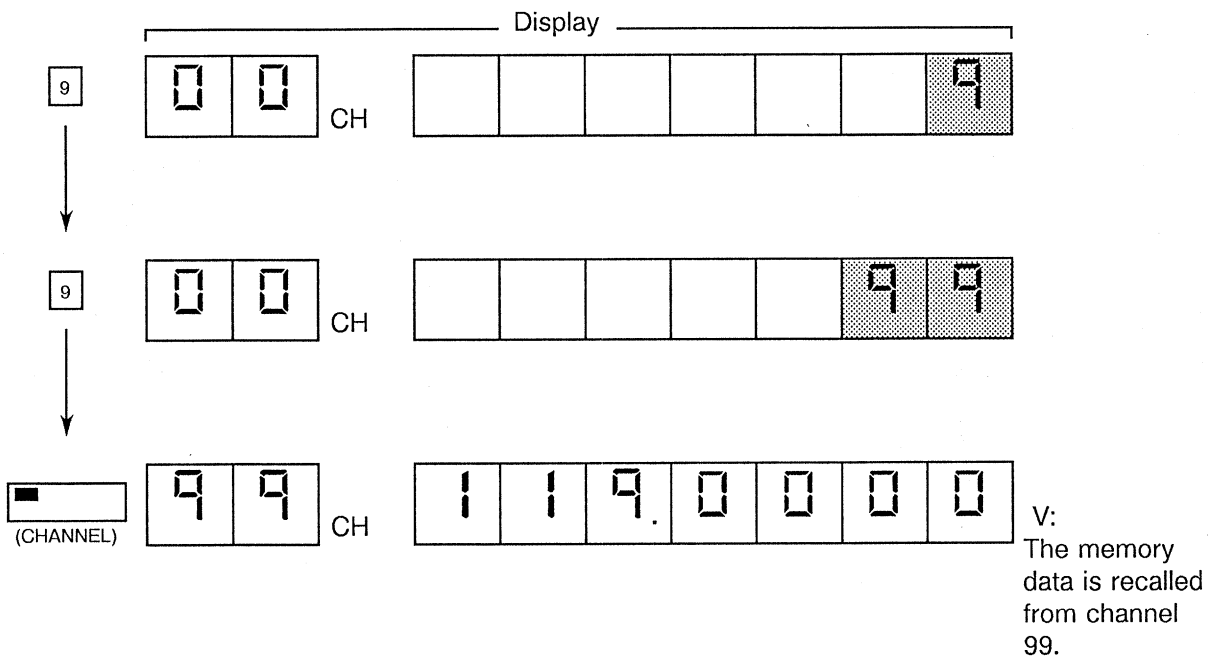

* If the output is ON (the OPERATE key lamp is on), the currently displayed data is output.

For the operations of the following recall modes, see Section 3.5.4.

- **Step**
The memory data is recalled sequentially from the first to last channels.
- **Single Scan**
The memory data is scanned only once from the first to last channels at the time interval specified by the Step Time parameter.
- **Repeat Scan**
The memory data is scanned repeatedly from the first to last channels at the time interval specified by the Step Time parameter.

3.5.4 Using the Step, Single Scan, and Repeat Scan Modes

The Generator has the STEP, SGL, and RPT function keys on its front panel. Use these functions to recall data from memory in the Recall mode.

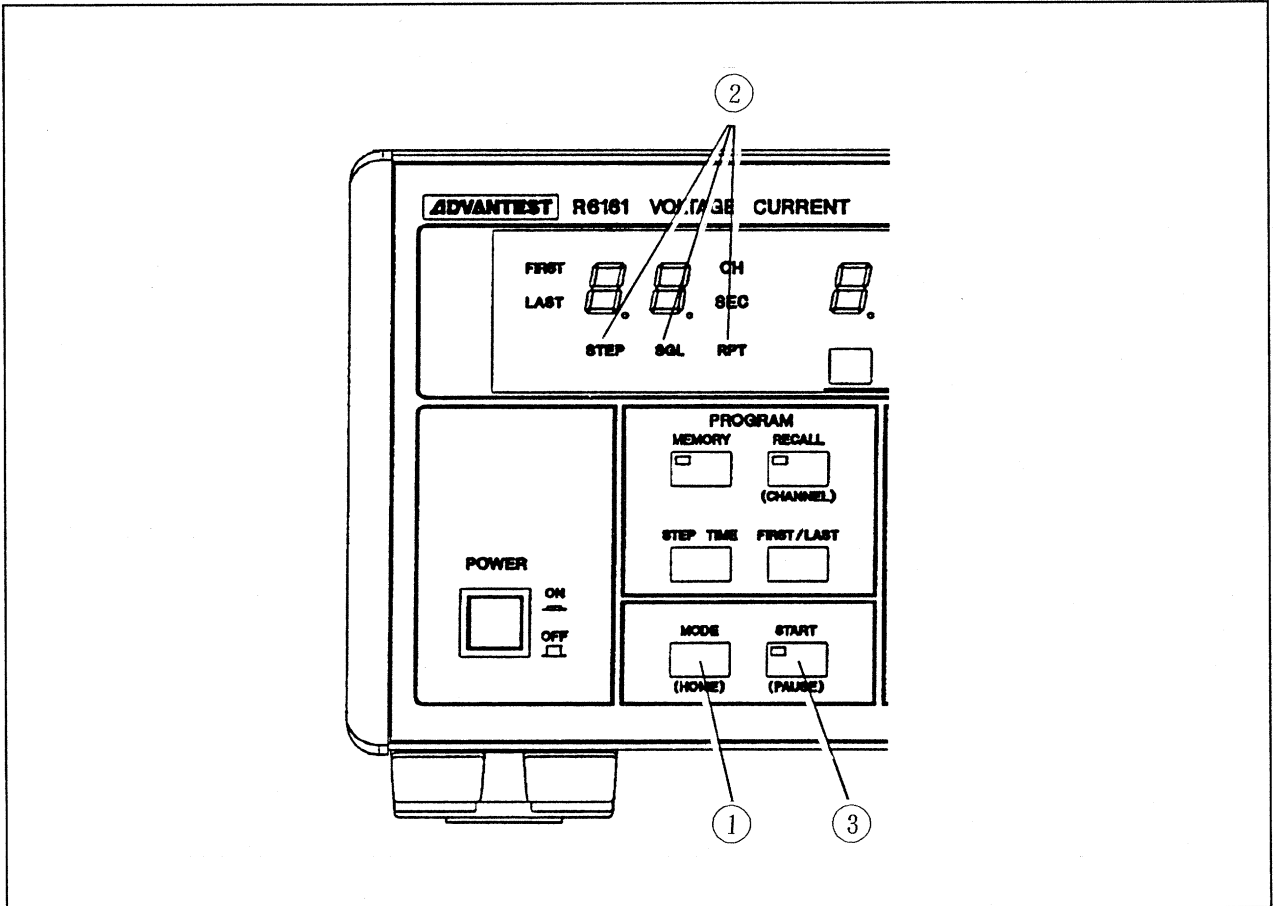

Figure 3-6 Generator Front Panel

(a) Step

The Step mode allows sequential scan of data from the first to last channels at any time interval.

- (1) Select the STEP option of STEP, SGL (Single Scan), or RPT (Repeat Scan) mode using

MODE
 key ①.

- * This can be set in the Memory or Recall mode.
- * The FIRST/LAST CH and Step Time cannot be checked or set in the Recall mode (see Sections 3.5.1 and 3.5.2). (It can be checked or set in the Memory mode.)

(2) Press ^{START} key ③ each time to call channel data from the first to last channels.

If you press the ^{START} key after you have recalled data from the last channel, the data is recalled from the first channel again.

* The lamp of ^{START} key is turned off when you press the _(HOME) key.

* When you press the ^{START} key after LAST CH data recall, data is recalled from the first channel again.

* To return to the FIRST CH data recall, press ^{MODE} key ①.

* You can also perform the same operations as [START] key ③ via the EXT TRIG terminal of the rear panel (see Section 5.6).

(b) Single Scan

The Single Scan mode allows a single time of data scan from the first to last and first channels at the time interval specified by the Step Time parameter.

(1) Select the "SGL" option of STEP, SGL (Single Scan), or RPT (Repeat Scan) mode using

^{MODE} key ①.

(2) Press ^{START} key ③, and all channel data is scan from the first to last and first channels only once at the Step Time interval. (After scan, the START lamp will go out, the FIRST CH data will be displayed (with output enabled), and the scan operation will stop.)

(c) Repeat Scan

The Repeat Scan mode allows the repeated data scan from the first to last channels at the time interval specified by the Step Time parameter (see Figure 3-6).

(1) Select the "RPT" option of STEP, SGL (Single Scan), or RPT (Repeat Scan) mode using

^{MODE} key ①. (② is switched repeatedly.)

(2) Press ^{START} key ③, and all channel data is scanned from the first to last channels continuously.









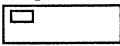

- * This mode can be selected in both the Memory and Recall mode.
- * The FIRST/LAST CH and Step Time cannot be checked or set in the Recall mode (see Sections 3.5.1 and 3.5.2). (It can be checked or set in the Memory mode.)
- * If you press ^{START} key ③ during startup, the lamp blinks and the scan operation pauses. When you press this key again, the data scan restarts from the stopped channel.
- * To return to the first channel during scan, press ^{MODE} key ①.
- * You can also perform the same operations as [START] key ③ via the EXT TRIG terminal of the rear panel (see Section 5.6).

3.5.5 Start/Pause/Home of Program Operation (in Recall mode)

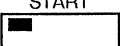
Use the program start, pause, and home functions to perform the following in the Recall mode:

- Start: Starts output from the first channel.
- Pause: Pauses scan from the first to last channels.
- Home: Stops scanning and returns to the first channel.

Table 3-12 Start/Pause/Home Control Modes

Application	Control switch	Step	Single Scan	Repeat Scan
To scan data from first to last channels	Press the  key.	Data scan starts from the first channel.		
		The  key lamp lights. Press it until the last channel scan.	The  key lamp lights until the last channel scan.	The  key lamp lights.
To output the channel data for the desired time period (during scan)	Press the  (PAUSE) key.	The  key lamp lights. (Do not press this key.)	Pauses at (any) current channel.	
			The [START] key lamp lights.	
To restart scanning from an intermediate position (after pause)	Press the  (PAUSE) key when its lamp is blinking.	—	The  key lamp lights but it goes out after LAST CH scan.	The  key lamp lights.
To return to FIRST CH scan forcibly	Press the  key.	Returned to the FIRST CH (and the  key lamp goes out).		

4. GPIB CONNECTION AND INTERFACING

4.1 Outline of GPIB Interface

The General Purpose Interface Bus (GPIB) is an interface system which can connect the Generator to a controller or a peripheral equipment using the simple signal cable (bus line). When compared with the conventional interface systems, the GPIB interface has much more flexible expandability, operability and compatibility with many products of other manufacturers in their electric, mechanical and functional characteristics. By using a single bus cable, your Generator can be configured to be a very simple system to a fully automatic measuring system having various powerful functions.

All devices and equipment of the GPIB system must first be connected to the bus line, and their "addresses" must be defined by the software. They can function as one or more of controllers, talkers and listeners.

When the system is operating, only one "talker" device can send data onto the bus line and multiple "listener" devices can receive data from the talker.

The "controller" device specifies the address of the "talker" and "listeners" and transfers data from the talker to the listeners or set the measuring conditions to the listeners from the controller itself (talker in this case).

Eight (bit parallel and byte serial) bus lines are used for data transmission between each device or equipment. Data can be transferred asynchronously in both directions. As the system devices operate asynchronously, both high-speed and low-speed processing devices can be combined and a flexible system can be configured.

The measuring data, measuring condition (programs), and various commands are transferred between devices. The ASCII codes are usually used for data transmission.

In addition to the above explained eight data lines, the GPIB has three handshaking lines for control of asynchronous data transmission between devices and five control lines for control of information flow on the buses.

- The following signals are sent on the handshaking lines.

DAV (Data Valid): The signal indicating the data validity

NRFD (Not Ready For Data): The signal indicating the data receive ready status

NDAC (Not Data Accepted): The signal indicating the data receive completion status

- The following signals are sent on the control lines.

ATN (Attention): The signal indicating that the signals sent on the bus line is either an address, command, or any other information

IFC (Interface Clear): The signal to clear the interface

EOI (End or Identify): The signal used at the end of information transmission

SRQ (Service Request): The signal used by any device to send a service request to the controller

4.1 Outline of GPIB Interface

REN (Remote Enable): The signal used for remote control of a device that can be controlled from a distant place

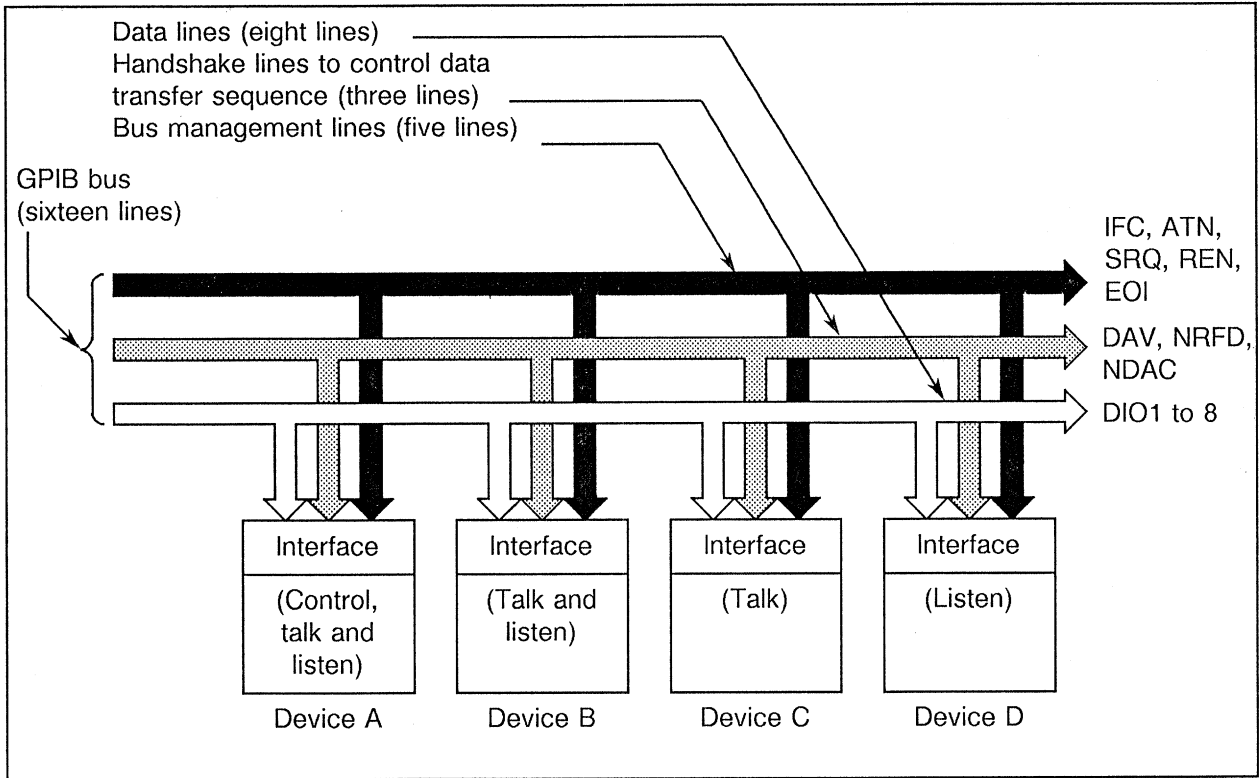

Figure 4-1 GPIB System Outline

4.2 GPIB Performance and Specifications

4.2.1 GPIB Specifications

Standard satisfied:	IEEE Standard 488-1978
Codes used:	ASCII and binary codes
Signal level:	+ 2.4 VDC or more for logical high status + 0.4 VDC or less for logical low status
Termination of signal line:	16 bus lines are terminated as follows.

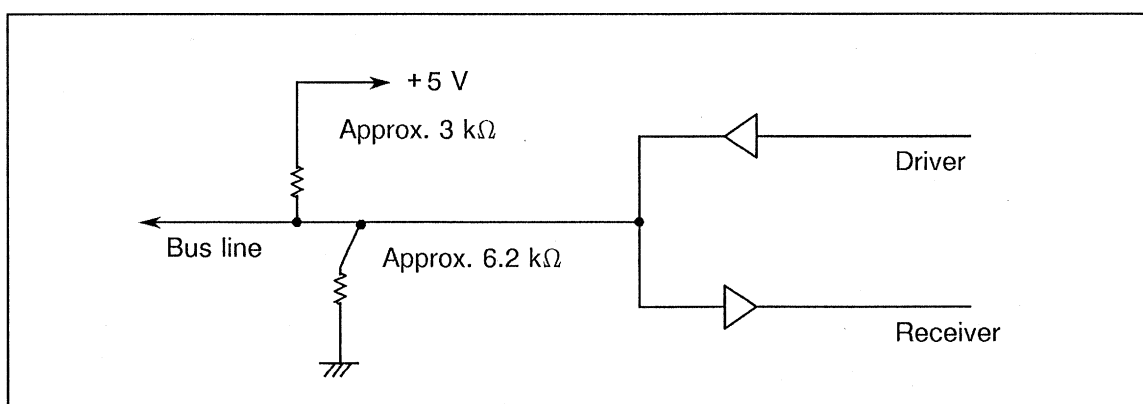

Figure 4-2 Termination of Signal Lines

Driver specifications:	Open collector Output voltage at low: + 0.4 VDC or less, 48 mA Output voltage at high: + 2.4 VDC or more, - 5.2 mA
Receiver specifications:	Low status at + 0.6 VDC or less High status at + 2.0 VDC or more
Length of bus cable:	The entire length of the bus cable (No. of devices connected to the bus x 2 meters or less) must not exceed 20 meters.
Address:	Up to 31 types of talk/listen addresses can be set to any desired value by using the address select switch on the front panel.
Connector:	24-pin GPIB interface connector Amphenol's 57-20240-D35 or equivalent

4.2.2 Interface Functions

Table 4-1 lists the standard interface functions.

Table 4-1 Interface Functions

Code	Function and explanation
SH1	The source handshaking function is provided.
AH1	The acceptor handshaking function is provided.
T6	The basic talker function, serial poll function, and talker release function specified by listener
L3	The basic listener function, listener release function specified by talker, and listen-only mode
SR1	The service request function is provided.
RL1	The remote function is provided.
PP0	The parallel poll function is not provided.
DC1	The device clear function is provided. (The "SDC" and "DCL" commands can be used.)
DT1	The device trigger function is provided. (The "GET" command can be used.)
C0	The controller function is not provided.
E2	The three-state bus driver is used.

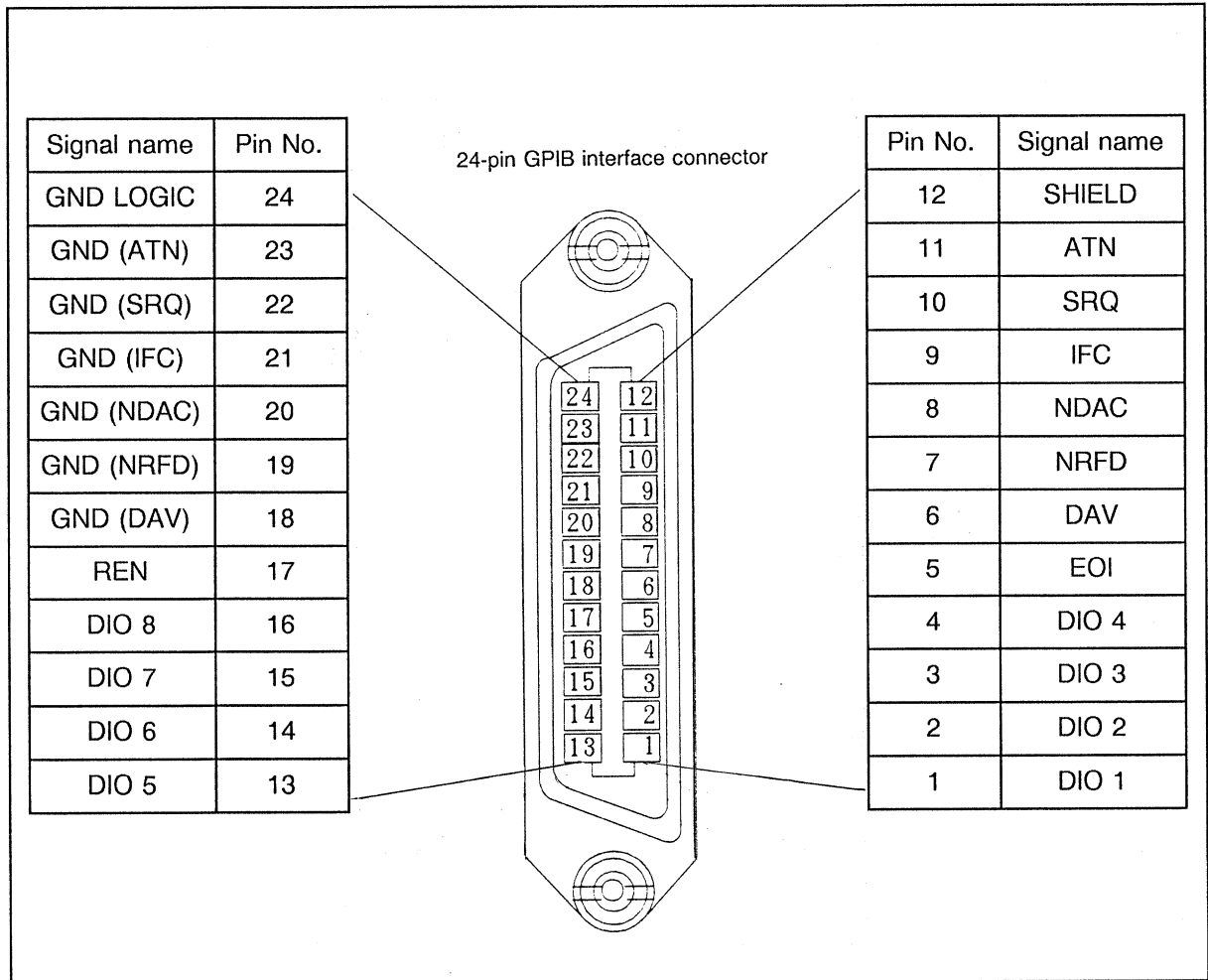

Figure 4-3 Pin Assignment of GPIB Interface Connector

4.3 GPIB Interface Application Notes

When using the GPIB interface, take the following considerations.

- (1) Cable connection and disconnection
Turn off the power supply of all connected devices and equipment before connecting or disconnecting their GPIB interface cables. Also, all devices and equipment must be grounded when you connecting or disconnecting these cables.
- (2) ATN interrupt during message transmission
If the message transmission between devices is interrupted by an ANT (Attention) request, this request has the highest priority and it is processed immediately. The previous status is cleared.
- (3) When your Generator is used in the Listen Only mode, the controller must not be connected to it.
- (4) The Generator enters the operation status defined on Table 4-2 when its power supply is turned on or when it receives various commands.

**R6161 PROGRAMMABLE REFERENCE
DC VOLTAGE/CURRENT GENERATOR
INSTRUCTION MANUAL**

4.3 GPIB Interface Application Notes

Table 4-2 Generator Status Change by Command Input

Command code	Talker (with lamp)	Listener (with lamp)	Remote (with lamp)	SRQ (with lamp)	Status byte	Transmis- sion data buffer	Parameter and operation status
POWER ON	Clear	Clear	Local	Clear	Clear	Clear	Partially initialized
IFC	Clear	Clear	–	–	–	–	–
"DCL" command	Clear	–	–	Clear	Clear	Clear	Partially initialized
"SDC" command	Clear	–	–	Clear	Clear	Clear	Partially initialized
"C" code	Clear	Set	Remote	Clear	Clear	Clear	Partially initialized
"Z" code	Clear	Set	Remote	Clear	Clear	Clear	Initialized
"GET" command	Clear	*	*	–	"b2" bit is cleared.	Clear	–
"E" code	Clear	Set	Remote	–	–	–	–
Talker setup for Generator	Set	Clear	–	–	–	–	–
Talker release order	Clear	–	–	–	–	–	–
Listener setup for Generator	Clear	Set	–	–	–	–	–
Listener release order	–	Clear	–	–	–	–	–
Serial polling	–	Clear	–	Clear	–	–	–

Notes: A hyphen indicates that the previous status continues.

An asterisk indicates that the status is undefined.

The status change may vary depending on the controller used.

DCL: Device Clear

SDC: Selected Device Clear

GET: Group Execute Trigger

**R6161 PROGRAMMABLE REFERENCE
DC VOLTAGE/CURRENT GENERATOR
INSTRUCTION MANUAL**

4.4 Device Address and Operation Mode (TR6120A or R6161) Setup

4.4 Device Address and Operation Mode (TR6120A or R6161) Setup

Use the CONTINUOUS keys to set the device addresses and select their operation modes.

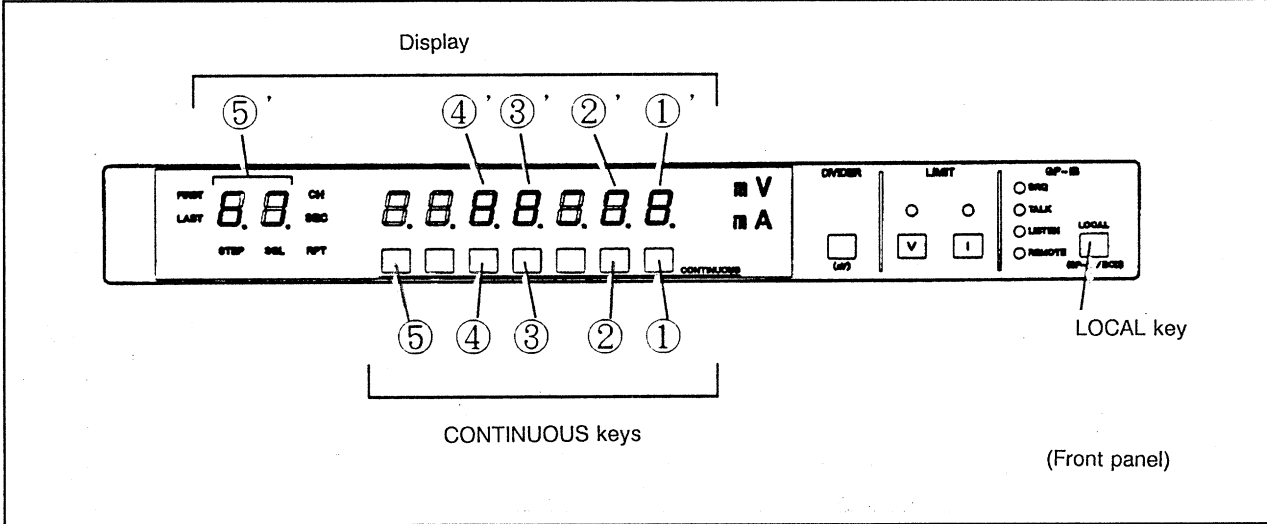

Figure 4-4 Display during LOCAL and CONTINUOUS Key Setup

Operation procedure:

- (1) Press the LOCAL key to select the GPIB Addressing mode.

CAUTION

If you continue pressing the LOCAL key, the following modes are switched one after the other.

→ GPIB Addressing mode → BCD Remote Setup mode → Normal operation mode →

- (2) Set the device address by pressing keys ① and ②.

- Whenever you press key ②, display ②' at the 10^1 digit changes as follows:

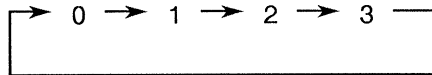

- Whenever you press key ①, display ①' at the 10^0 digit changes as follows:

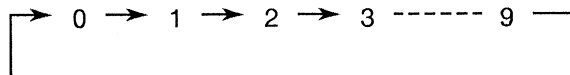

R6161 PROGRAMMABLE REFERENCE
DC VOLTAGE/CURRENT GENERATOR
INSTRUCTION MANUAL

4.4 Device Address and Operation Mode (TR6120A or R6161) Setup

- (3) Select the Addressable or Listen Only mode by pressing key ③.

Whenever you press key ③, display ③' at the 10³ digit switches between **A**
(Addressable) and **□** (Listen Only).

In the Listen Only mode, the **— —** message is displayed at the device address.

- (4) Set the use or no use of header for the talker data by pressing key ④.

Whenever you press key ④, display ④' is switched between **H**
(Use of header) and **—** (No use of header).

- Press the **ENTER** key, and the GPIB interface setup (display data) will be set in the Generator.
- To cancel the entry and reset to the original status, press the **LOCAL** key.
- If the device address is 31 or greater and if you press the **ENTER** key, the " **E r r . G A d** " message is displayed and the data before being modified is redisplayed.

- (5) Select the GPIB Remote Code mode by pressing key ⑤.

Whenever you press key ⑤, display ⑤' is switched between **b i**
(R6161 mode) and **2 0** (TR6120A mode).

4.5 Listener Format

This section explains the program codes that you can use to control your Generator in the remote control mode via the GPIB interface.

4.5.1 Program Codes (R6161 mode)

- (1) Use the ASCII program codes.
- (2) Use a comma (,) as the string delimiter. However, it may be omitted unless otherwise specified.
Example: "V4,GRD1" may be specified as "V4GRD1"
(The string delimiter of a comma is omitted.)
- (3) You can use one of the following four block delimiter codes and EOI (End or Identify) of single-line signals.
 - 1) CR, LF (EOI)
 - 2) LF (EOI)
 - 3) CR (EOI)
 - 4) (EOI)
- (4) The Generator can receive up to 400 characters of program codes (including string delimiters but excluding block delimiters) at a time.
- (5) If the length of the program codes exceeds the limit or if the program codes contain an invalid code, a command syntax error occurs.
If a command syntax error has occurred, all codes between the error code and the block delimiter are made invalid.

4.5.2 List of Program Codes (R6161 mode)

Table 4-3 List of Program Codes in R6161 Mode

Function/Name	Program code	Contents	Initial value set by program code "C"	Effective program code during scan in program mode
(1) Operate/ Standby		Output status		
Operate	OP, E	Operate status		○
Standby	SB, H	Standby status	○	○
(2) Function/Range	*V2, V3 and V9 are Divider range.			
DC voltage output mode 10 mV 100 mV 1000 mV 1 V 10 V 100 V 1000 V	V2 (Divider) V3 (Divider) V9 (Divider) V4 V5 V6 V7	DC voltage output mode 10 mV range 100 mV range 1000 mV range 1 V range 10 V range 100 V range 1000 V range	○	
DC current output mode 1mA 10 mA 100 mA	I1 I2 I3	DC current output mode 1 mA range 10 mA range 100 mA range		
(3) Switching of Sense		Switching of Sense		Possible during Step setup in Recall mode
INT. SENSE	SEN0	Internal Sense		
EXT. SENSE	SEN1	External Sense		
(4) Switching of Guard		Switching of Guard		
INT. GUARD	GRD0	Internal Guard		
EXT. GUARD	GRD1	External Guard		

**R6161 PROGRAMMABLE REFERENCE
DC VOLTAGE/CURRENT GENERATOR
INSTRUCTION MANUAL**

4.5 Listener Format

(Cont'd)

Function/Name	Program code	Contents	Initial value set by program code "C"	Effective program code during scan in program mode
(5) Memory function		Memory function		
Data recall from specified channel	RCL x (x = Channel 0 to 99)	Recalls data from the specified channel.		
Step Time setup	STM x (x = 1 to 99 sec)	Sets the Step Time.		
Scan Channel setup	SCx,y (x = 0 to 99; y = 0 to 99) x: First channel y: Last channel	Sets the scan channel. $x \leq y$		
(6) Recall setup		Selects the Recall mode.		
Single	ST0	Single Scan mode		
Repeat	ST1	Repeat Scan mode		
Step	ST2	Step Scan mode		
(7) Program function		Controls the program functions.		
Start	STT, *TRG	Start command		○
Pause	PAU	Pause command		○
Continue	STT	Continue (or Restart) command		○
Stop	STP	Stop command	○	○
(8) Block delimiter setup		Sets the block delimiters.		
CR, LF (EOI)	DL0	CR, LF (EOI)	○	○
LF only	DL1	LF only		○
(EOI) only	DL2	(EOI) only		○
LF (EOI)	DL3	LF (EOI)		○

**R6161 PROGRAMMABLE REFERENCE
DC VOLTAGE/CURRENT GENERATOR
INSTRUCTION MANUAL**

4.5 Listener Format

(Cont'd)

Function/Name	Program code	Contents	Initial value set by program code "C"	Effective program code during scan in program mode
(9) SRQ transmission		Switching of SRQ transmission		
Does not send SRQ.	S1	The SRQ is not sent. (SRQOF)	○	○
Sends SRQ.	S0	The SRQ is sent. (SRQON)		○
(10) Clear of status byte	*CLS	The status byte is cleared to all zeros.	○	○
(11) Mask of status byte	SMS x (x = 0 to 255)	The specified bits of status byte are masked. (255 for all bit enabled)	SMS 255	○
(12) Initialize	C	The GPIB setup is initialized, the output is turned off, and all operations are stopped. Direct operation mode: Zero in 1 V range Program operation mode: Stopped and returned to the first channel. Same as for 'SDC' and 'DCL'	○	
(13) Initialize R6161	*RST, Z	The R6161 is initialized (the battery backed up program data and each parameter are initialized). It includes the 'C', 'SDC' and 'DCL' processing.		

(Cont'd)

Function/Name	Program code	Contents	Initial value set by program code "C"	Effective program code during scan in program mode
(14)Limit value setup		The limit value is set. (It cannot be set using Divider function.)		
DC voltage limit	VL x (x = 10 to 1250) in 10 V step	The DC voltage output is limited.	VL130	
DC current limit	IL x (x = 1 to 125) in 1 mA step	The DC current output is limited.	IL125 IL13 for 1000 V range or 1 mA or 10 mA range of option 01	

4.5.3 Parameter Store in Memory (R6161 mode)

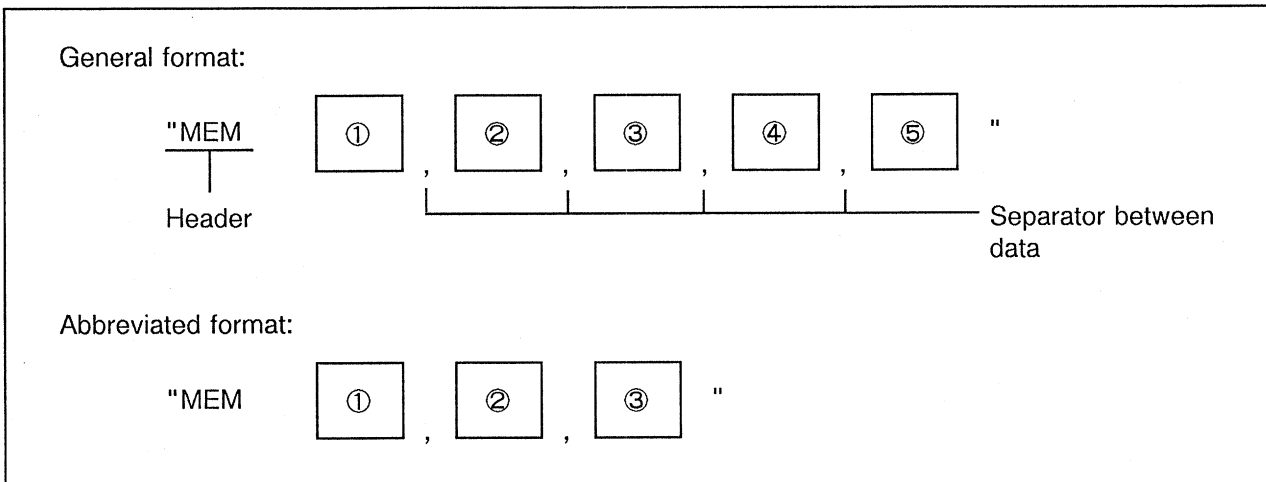

- ① Channel number
Up to two characters; channel 0 to 99
- ② Range setup
The Range setup format must be satisfied.
- ③ Setup of output data
The output data setup format must be satisfied.
Note: If the Range is fixed and the unit is used, an error occurs.
- ④ Voltage limit setup
The voltage limit setup format must be satisfied.
Note: If omitted, it is set to 130 V. It cannot be set by the Divider function.
- ⑤ Current limit setup
The current limit setup format must be satisfied.
Note: If omitted, 125 mA is set. However, 13 mA is set for the 1000 V range or 1 mA or 10 mA range of option 01.

CAUTION

1. If the abbreviated format is used (that is, if VL and IL are omitted for parameters ①, ② and ③ above), the default voltage/current limit value is set.
2. If an error has occurred in the entry enclosed by double quotation marks (") of the parameter either in the general format or abbreviated format, the entry data is ignored.
3. If an error has occurred, the subsequent codes are ignored.

Example: OUTPUT 708;"V2,VL50,GRD1"

Ignored.

An error (Err G15) has occurred.

4. Set the memory for Divider function by using a single command sentence. You cannot set the voltage/current limit for V2, V3 and V9.

Example: Incorrect example

OUTPUT 708;"MEM00,V2,D10,VL50,IL10"

Correct example

OUTPUT 708;"MEM00,V2,D10"

Error G16 An error (Err G16) has occurred and the input data is ignored.

4.5.4 Format of Direct Setup Program Codes for DC Voltage/Current Output (R6161 mode)

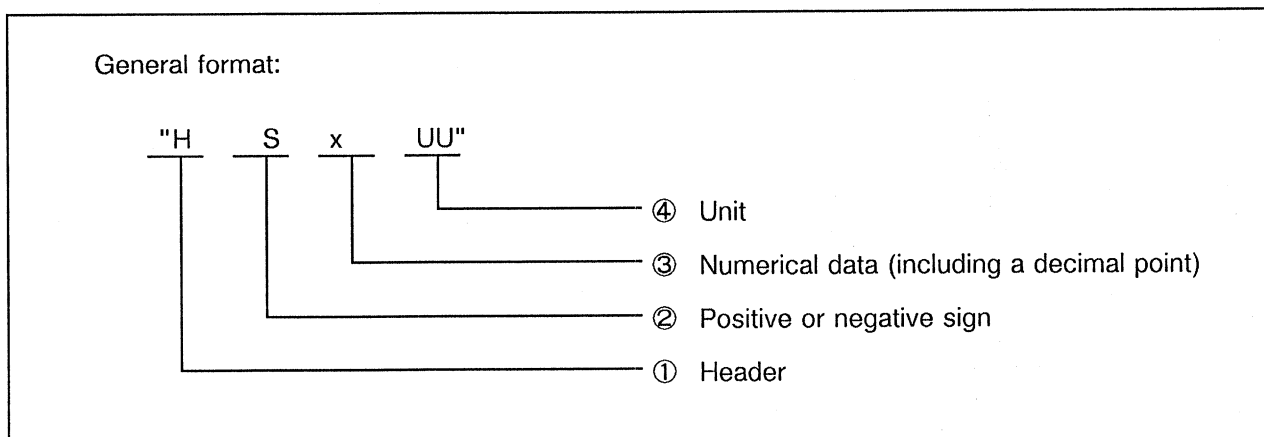

① Header

Indicates the remote code header for direct setup of DC voltage or current.
Always specify the header of "D" for direct setup.

② Positive or negative sign

Indicates the positive or negative value of the set data as follows.

1: +	} (Positive value)
2: Space	
3: Omitted	
4: -	

③ Numerical data

Numerical data: Up to 7 characters. An excess is truncated.
Decimal point: Can be used or can be omitted.

④ Unit

DC voltage function

MV:	Auto Range
V:	Auto Range
Omitted:	Fixed range

Notes: mV: The Auto Range is set for 10 mV, 100 mV or 1000 mV range.
V: The Auto Range is set for 1 V, 10 V, 100 V or 1000 V range.

DC current function

MA: Auto Range

Omitted: Fixed range

Note: If an error has occurred, the subsequent codes are all ignored.

Example: OUTPUT 708;"V2, VL50, GRD1"

Ignored.

Err G15 has occurred.

4.5.5 Program Codes (TR6120A mode)

- (1) Use the ASCII program codes.
- (2) The string delimiter of a comma (,) can be used. It can also be omitted.
Example: "V4,L1" → "V4L1" (if the delimiter is omitted)
- (3) One of the following four codes and EOI (End or Identify) code can be used as the block delimiter.
 - 1) CR, LF (EOI)
 - 2) LF (EOI)
 - 3) CR (EOI)
 - 4) (EOI)
- (4) The Generator can receive up to 400 characters of program codes (including string delimiters but excluding block delimiters) at a time.
- (5) If the length of the program codes exceeds the limit or if the program codes contain an invalid code, a command syntax error occurs.
If a command syntax error has occurred, all codes between the error code and the block delimiter are made invalid.

4.5.6 List of Program Codes (TR6120A mode)

Table 4-4 List of Program Codes in TR6120A Mode

Function/Name	Program code	Contents	Initial status
(1) Operate/ Standby		Output status	
Operate	E	Operate status	
Standby	H	Standby status	○
(2) Function/Range			
DC voltage output		DC voltage output	○
1 V	V4	1 V range	
10 V	V5	10 V range	
100 V	V6	100 V range	
1000 V	V7	1000 V range	
DC current output		DC current output	
1 mA	I1	1 mA range	
10 mA	I2	10 mA range	
100 mA	I3	100 mA range	
(3) Limit value setup		The limit value is set.	
DC voltage limit		DC voltage limit	○
10 V	L1	10 V	
130 V	L2	130 V	
300 V	L3	300 V	
1300 V	L4	1250 V	
DC current limit		DC current limit	○
5 mA	L5	5 mA	
13 mA	L6	13 mA	
50 mA	L7	50 mA	
130 mA	L8	125 mA	
(4) SRQ transmission		Switching of SRQ transmission	
Sends an SRQ.	S0	The SRQ is sent.	
Does not send SRQ.	S1	The SRQ is not sent.	○
(5) Initialize	C	The GPIB setup is initialized. ● Range: 1 V ● Output: 0.000000, Standby	

4.5.7 Format of Direct Setup Codes for DC Voltage/Current Output

General format:

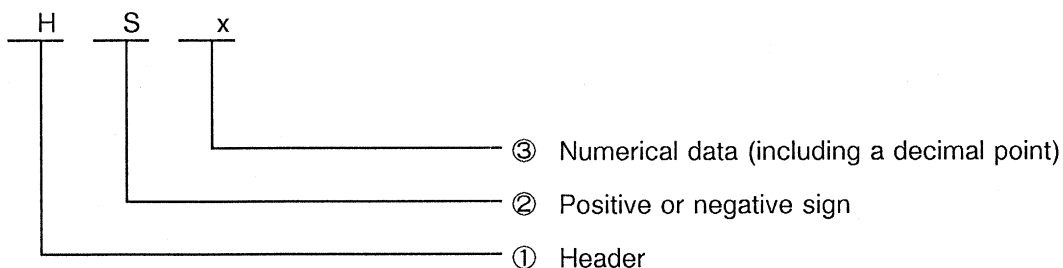

- ① Header
Indicates the remote code header for direct setup of DC voltage or current.
Always specify the header of "D" for direct setup.

- ② Positive or negative sign
Indicates the positive or negative value of the set data as follows.

1: +	}	(Positive value)
2: Space		
3: Omitted	}	(Negative value)
4: -		

- ③ Numerical data
Numerical data: Up to 7 characters. An excess is truncated.
Decimal point: Can be used or can be omitted.

CAUTION

In the TR6120A mode, the fixed range is used for direct setup.

4.6 Parameter Read Codes (Query)

When the Generator receives a query code and when it is specified to be the talker, the Generator sends the set value of a parameter specified by the query.

(For typical examples, see Example 5-1 of the sample program.)

Table 4-5 Parameter Read Codes

Parameter	Query	Send code	Contents
(1) Sense status	SEN?	SEN0 SEN1	Internal sense status External sense status
(2) Guard status	GRD?	GRD0 GRD1	Internal guard status External guard status
(3) Step time	STM?	STMx x:01 to 09	Step time (in seconds)
(4) First/Last • Channel • Number	SC?	SCx, y x: First channel No. (x = 00 to 99) y: Last channel No. (y = 00 to 99)	First channel number Last channel number
(5) Recall mode	ST?	ST0 ST1 ST2	Single Recall mode Repeat Recall mode Step Recall mode
(6) Company name, product name, and revision	* IDN?	ADVANTEST, R6161, REV A01	R6161 environment
(7) Block delimiter	DL?	DL0 DL1 DL2 DL3	CR, LF (EOI) LF only (EOI) only LF (EOI)
(8) SRQ send status	SRQ?	SRQOF SRQON	The SRQ is not sent. The SRQ is sent.

(Cont'd)

Parameter	Query	Send code	Contents																
(9) Result of self-diagnostic test	*TST?	(A single numeric byte) 0 to 15	<table border="1" style="margin-left: auto; margin-right: auto;"> <tr> <td>B7</td><td>B6</td><td>B5</td><td>B4</td><td>B3</td><td>B2</td><td>B1</td><td>B0</td> </tr> <tr> <td style="width: 20px; height: 15px;"></td> <td style="width: 20px; height: 15px;"></td> <td style="width: 20px; height: 15px;"></td> <td style="width: 20px; height: 15px;"></td> <td style="width: 20px; height: 15px;"></td> <td style="width: 20px; height: 15px;"></td> <td style="width: 20px; height: 15px;"></td> <td style="width: 20px; height: 15px;"></td> </tr> </table> <p>B0: ROM sum error B1: RAM read error B2: RAM parameter error B3: EEPROM data error B4: Fan stop error B5 to B7: Always 0</p>	B7	B6	B5	B4	B3	B2	B1	B0								
B7	B6	B5	B4	B3	B2	B1	B0												
(10) Status byte	*STB?	(A single numeric byte) 0 to 255	Same as the bit contents of status byte																
(11) Mask register of status byte	SMS?	(A single numeric byte) 0 to 255	The contents of mask bit of status byte (equal to the bit contents of serial poll enable register)																

4.6.1 Batch Read of Current Parameter Data

The following shows a response to the "PANE?" (Query).

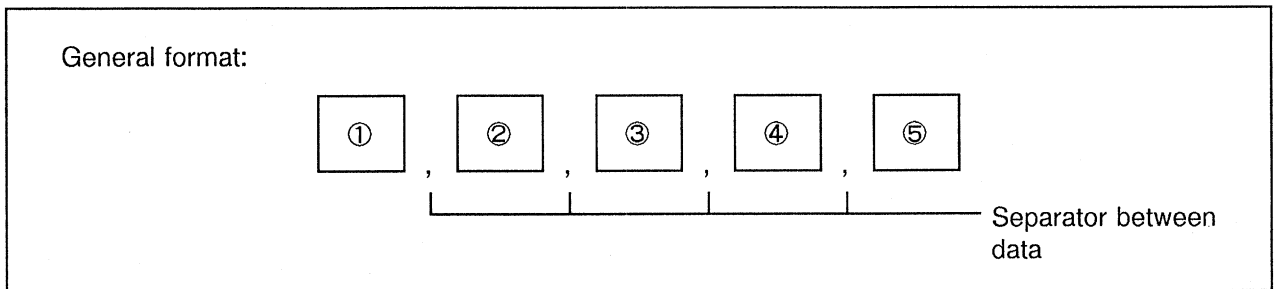

Each data format:

① Setting range

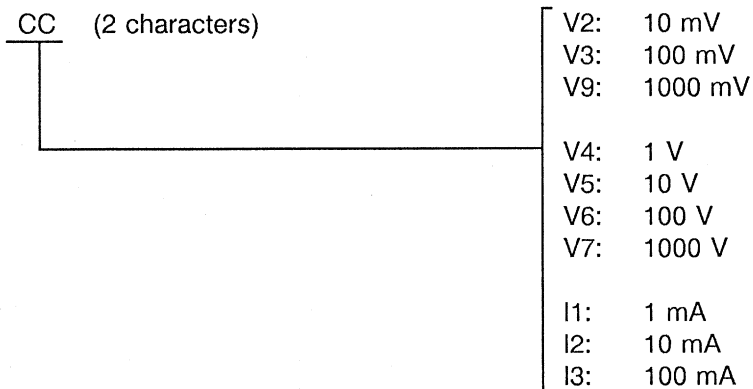

② Output value

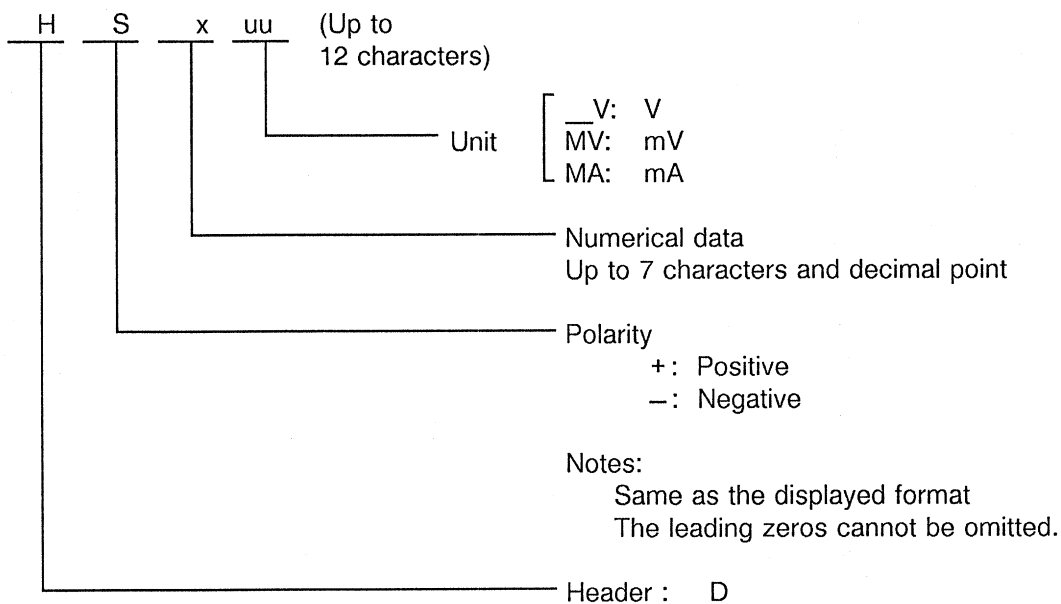

③ Output voltage limit

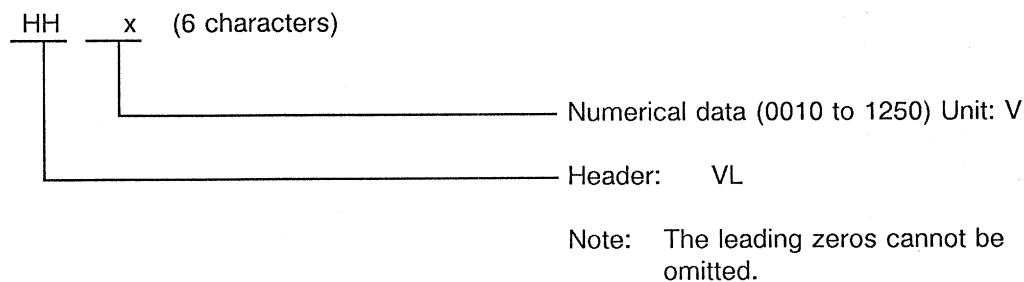

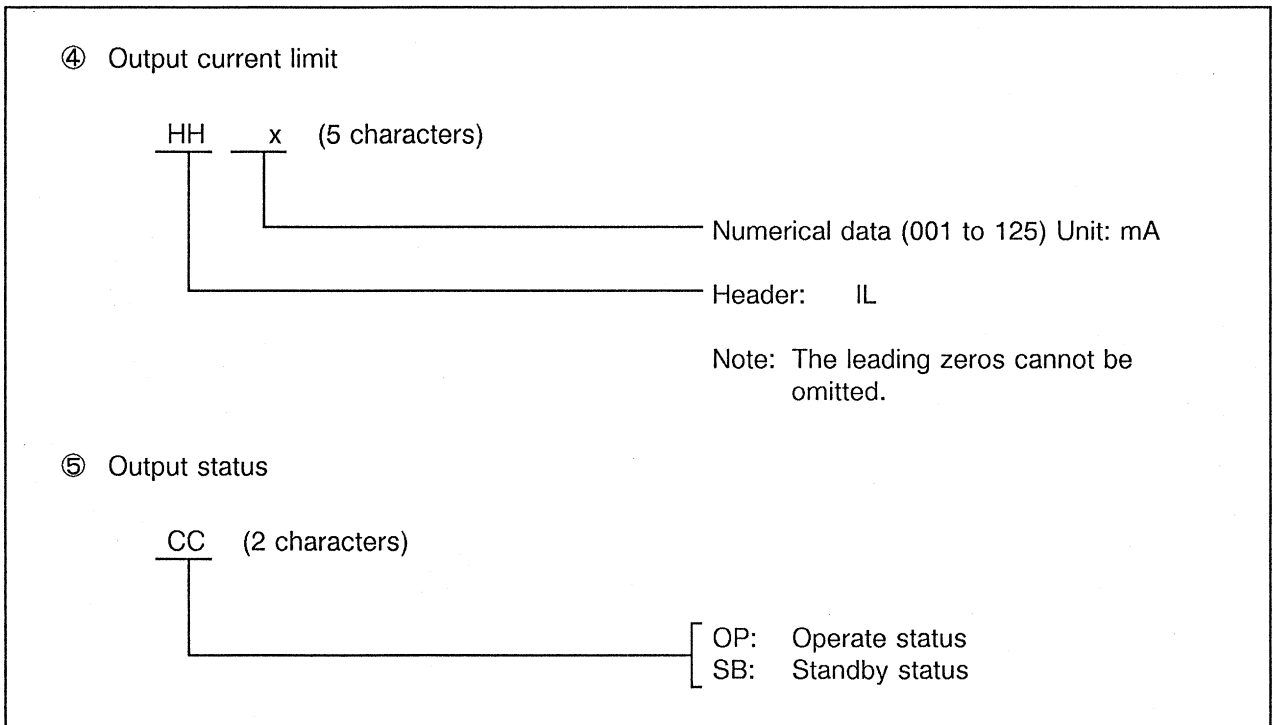

4.6.2 Data Read from Specified Memory

The following shows a response to "MEM○○?" (Query).

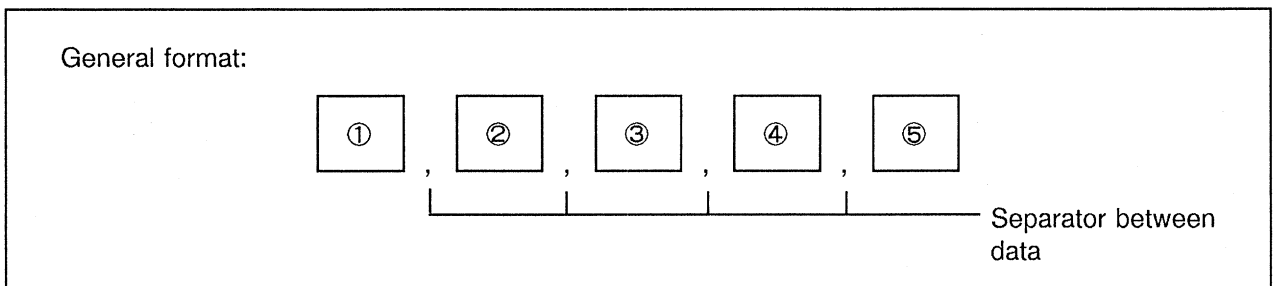

Each data format:

① Memory No.

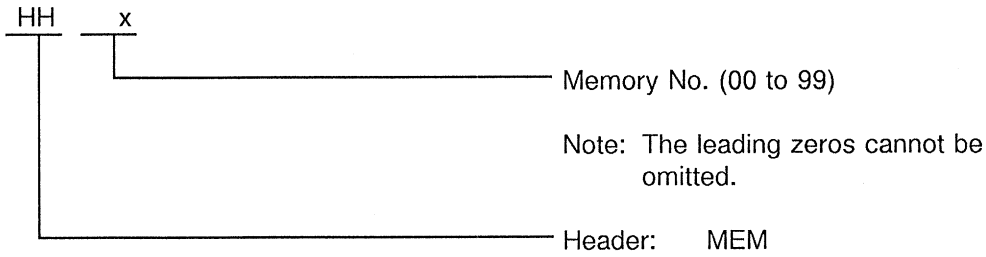

② Setting range

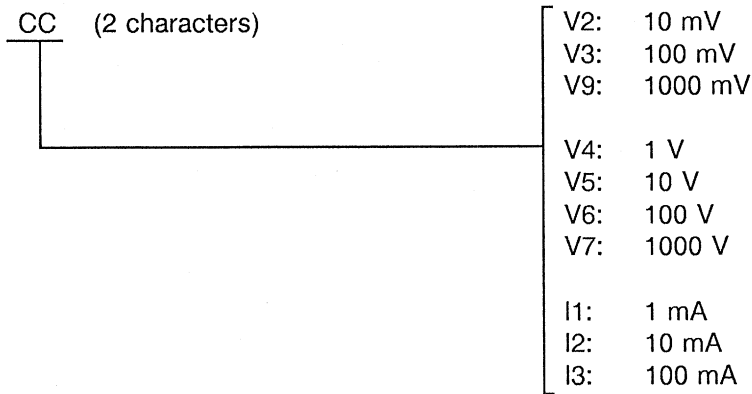

③ Output value

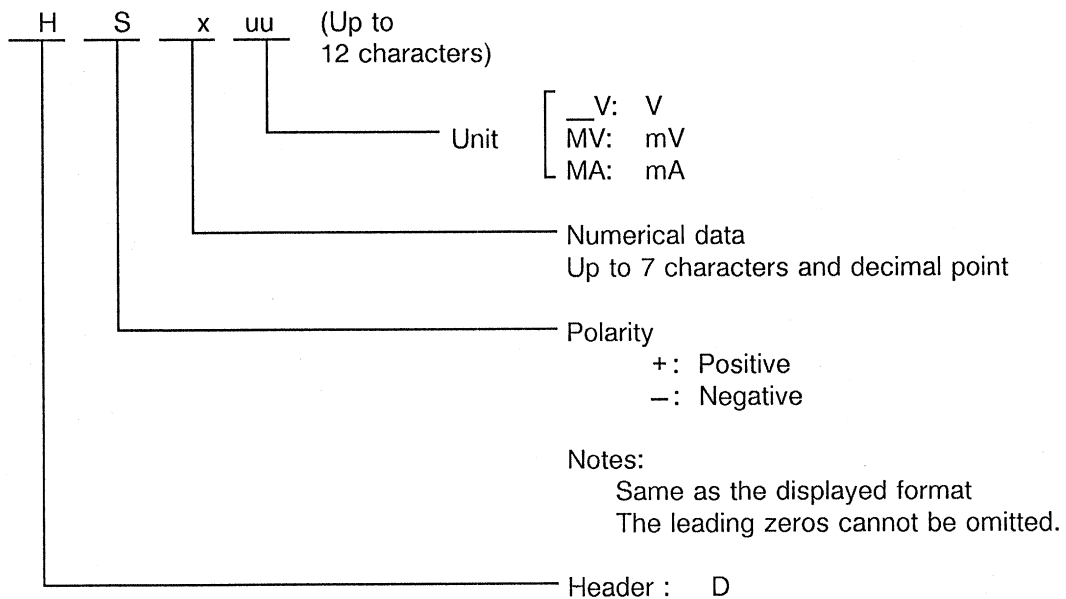

④ Output voltage limit

HH x (6 characters)

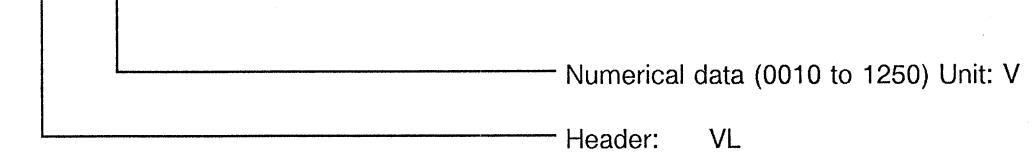

Note: The leading zeros cannot be omitted.

⑤ Output current limit

HH x (5 characters)

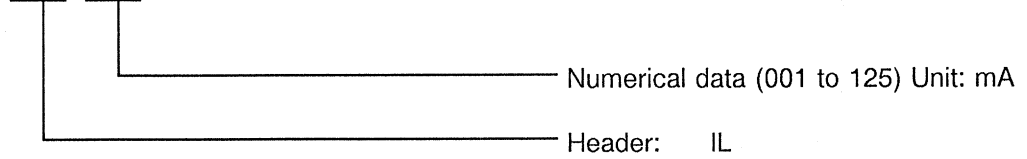

Note: The leading zeros cannot be omitted.

4.6.3 Data Read from Specified Memory Area

The following shows a response to "MEMx,y?" (Query).

The contents of memory area between memory numbers "x" and "y"

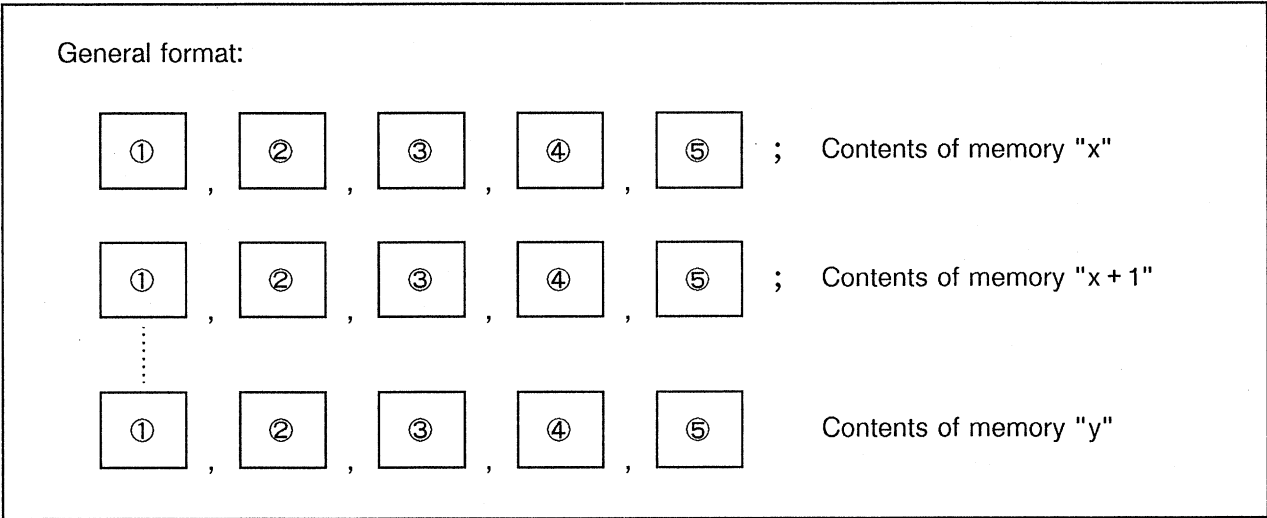

Each data format:

Each data format of parameters ① to ⑤ are the same as those explained in Section 4.6.2.

4.7 Service Request and Status Byte

The Generator shows the limit status and others using its status byte. In addition, the Generator can issue a service request (SRQ) to the GPIB controller if a fault has occurred.

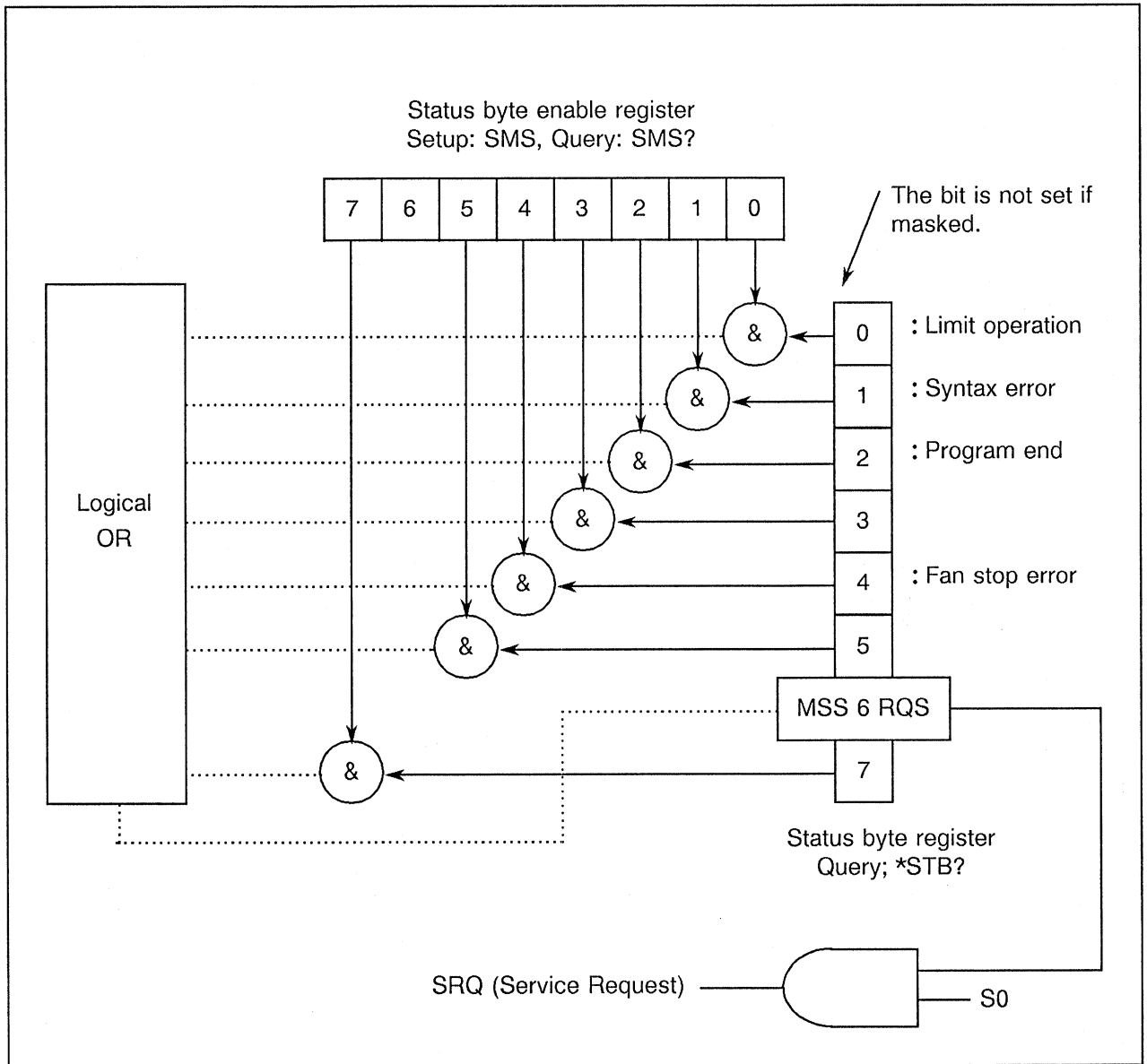

Figure 4-5 Relationship between Status Byte and Mask Register (SMS)

CAUTION

If each bit of the status byte register is masked, these bits are kept in logical 0 even if an error has occurred. Therefore, the Generator does not send an SRQ. If you read the register contents by issuing a query (*STB?), zero is returned.

4.7.1 Structure of Status Byte Register (R6161 mode)

(1) Structure explanation

In the R6161 mode, the status byte consists of eight bits as shown below. The Generator sends this status byte when it receives an SPE command during serial polling by the controller and when it is specified to be the talker.

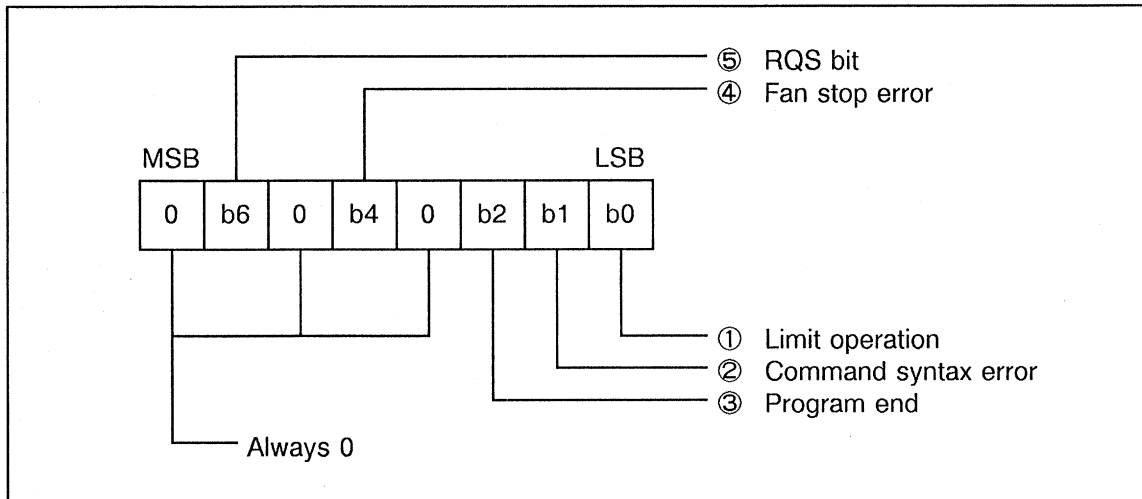

- ① b0: Limit operation
When an output limit has occurred, bit 0 is set to 1.
When the output limit is released, it is cleared to 0.
- ② b1: Command syntax error
When an undefined program code is received, when a parameter of the program code has exceeded the limit, or when the program code is too long, this bit is set to 1.
When the correct program code is received, it is cleared to 0.
- ③ b2: Program end
When the last channel operation is completed in the program mode, this bit is set to 1.
When the program is started to execute in the program mode, it is cleared to 0.
- ④ b4: Fan stop error
When the fan stops rotating, this bit is set to 1.
When the power switch is turned off and when it is turned on again, it is cleared to 0 (if the fan rotates normally).
- ⑤ b6: RQS bit
When one of bits 0, 1, 2 and 4 is 1, this bit is set to 1.
When all of bits 0, 1, 2 and 4 are 0, it is cleared to 0.

(2) Limit operation and status byte

① Limit bit (bit 0)

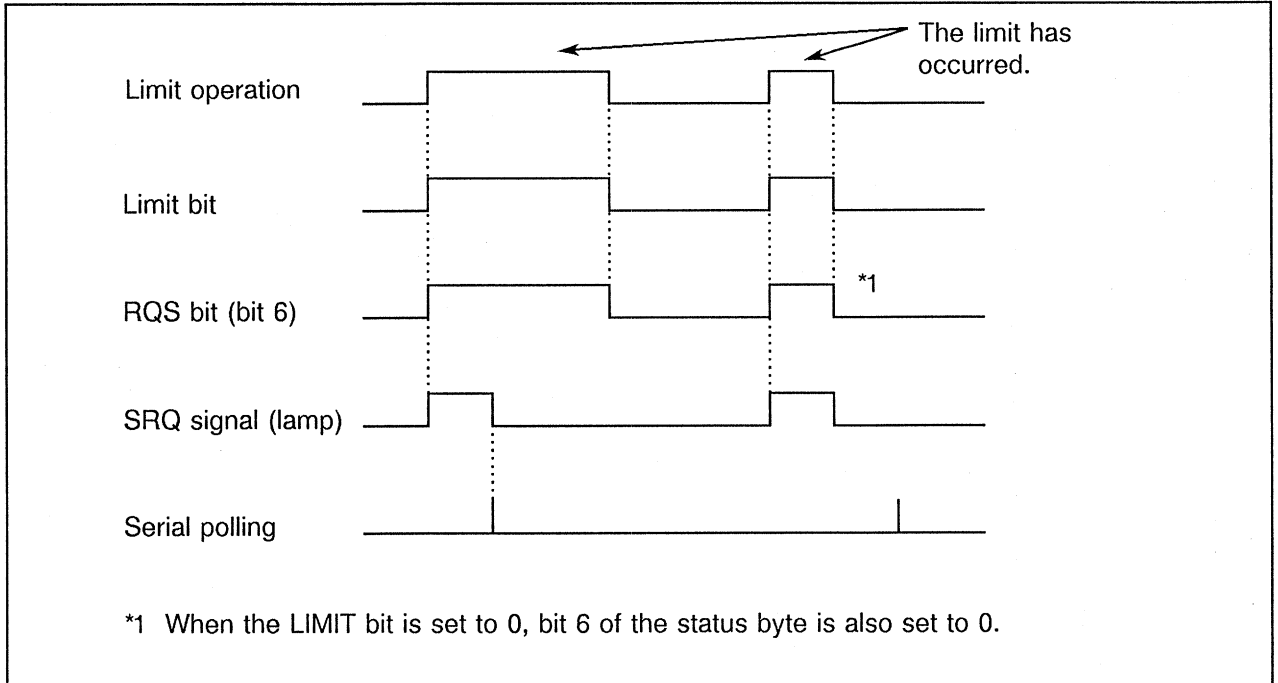

Figure 4-6 Timing of Limit Bit (R6161 mode)

② Syntax Error bit (bit 1)

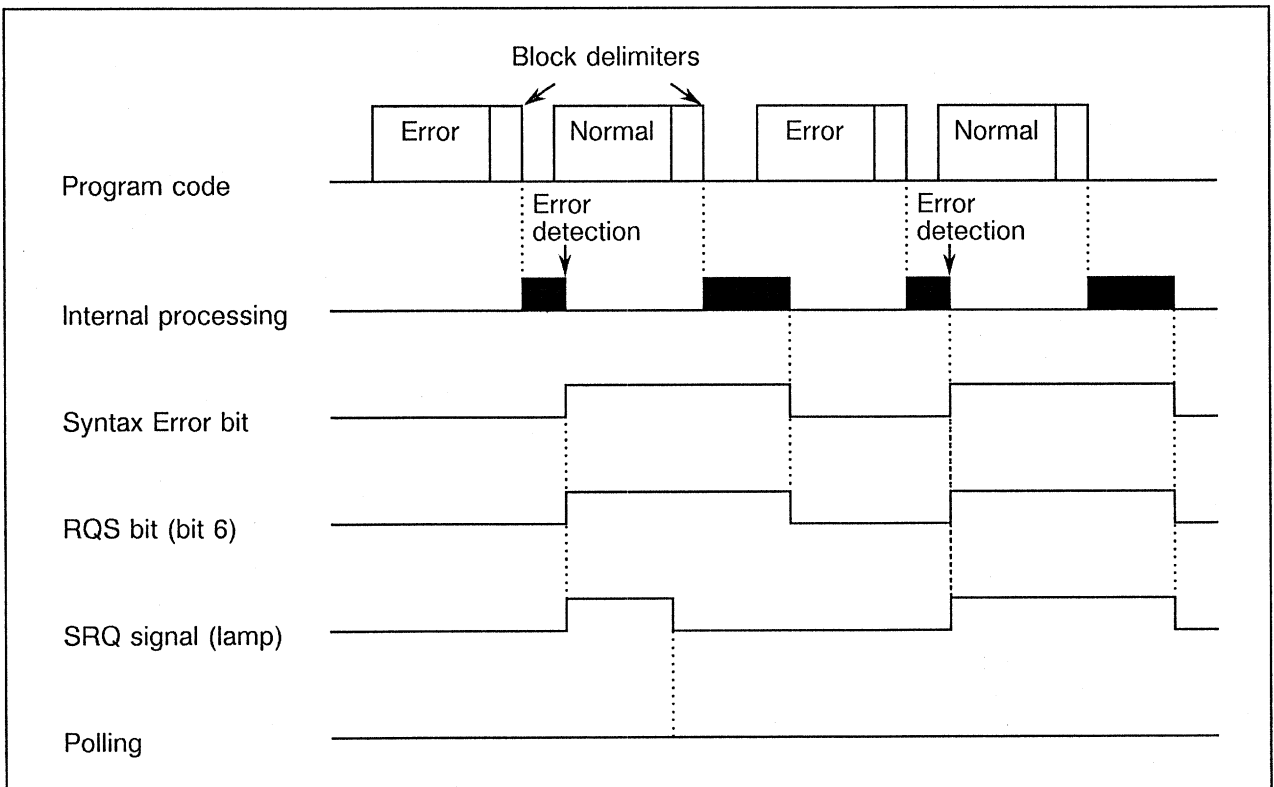

Figure 4-7 Timing of Syntax Error Bit (R6161 mode)

③ Program end (bit 2)

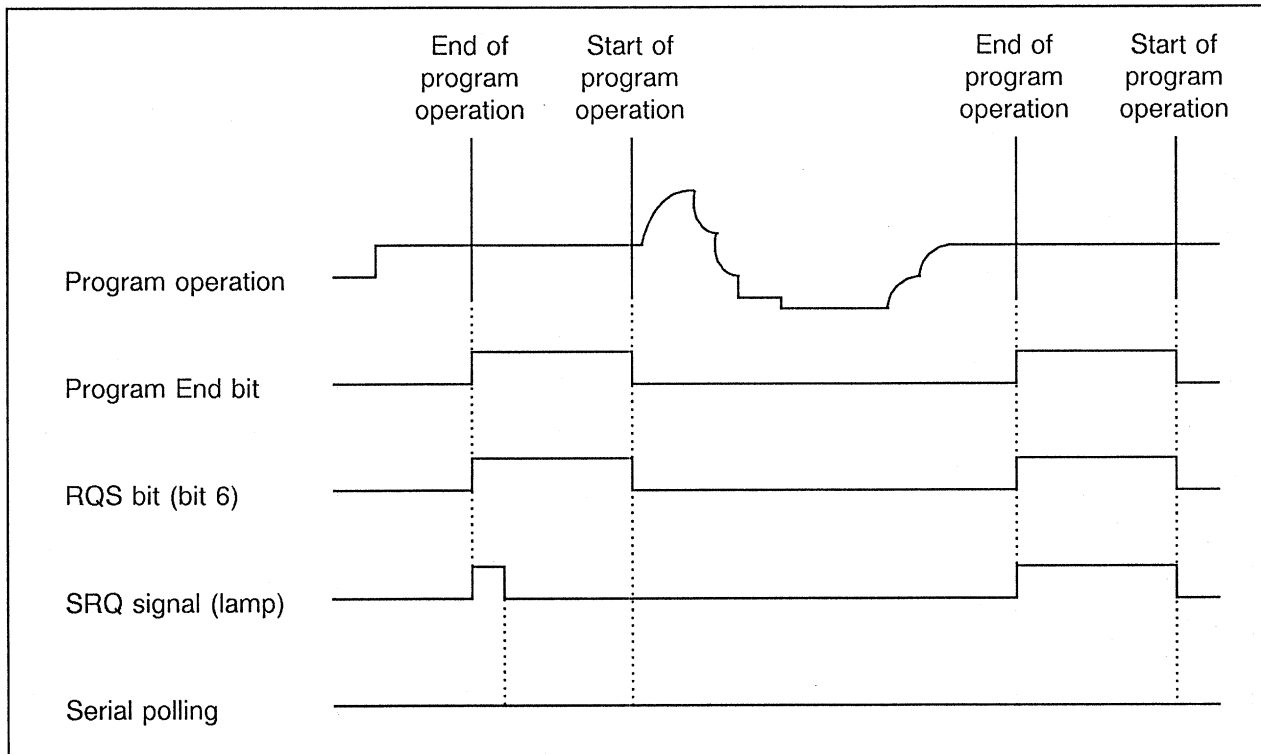

Figure 4-8 Timing of Program End (R6161 mode)

CAUTION

1. Repeat scan and program end status
During repeat scan, the Program End bit is set at the end of program operation. However, this bit is cleared when the first channel operation has started. In this case, bit 2 is kept to 0 even when a service request is issued.
2. In the Repeat Scan mode, approximately 15 msec of delay time exists between the Program End bit and the startup of program operation.
3. Difference between the read of "*STB?" of the status byte and the serial polling
 - "*STB?"
The status byte register is specified as the destination of output data from the talker. When a talker output request is issued, its data is sent. When "*STB?" is executed, bit 1 for syntax error is updated and set to 0. However, bit 0 (Limit) and bit 2 (Program end) are not updated even when "*STB?" is executed.
 - Serial polling
The status does not change even when serial polling is repeated unless the cause of limit operation, syntax error, or program end is removed.
Example: When the Limit has occurred, a syntax error has occurred, or a program has ended, the respective status of 65, 66, or 68 does not change.

4.7.2 Structure of Status Byte Register (TR6120A mode)

(1) Structure explanation

In the TR6120A mode, the status byte consists of eight bits as shown below.

The Generator sends this status byte when it receives an SPE command during serial polling by the controller and when it is specified to be the talker.

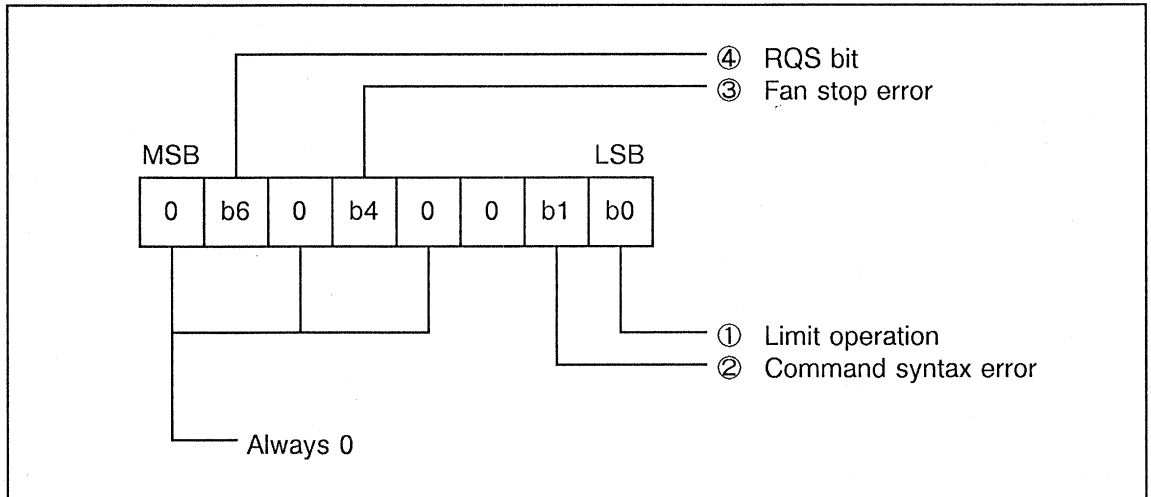

- ① b0: Limit operation
When an output limit has occurred, bit 0 is set to 1.
When the output limit is released, it is cleared to 0.
- ② b1: Command syntax error
When an undefined program code is received, when a parameter of the program code has exceeded the limit, or when the program code is too long, this bit is set to 1.
When the correct program code is received, it is cleared to 0.
- ③ b4: Fan stop error
When the fan stops rotating, this bit is set to 1.
When the power switch is turned off and when it is turned on again, it is cleared to 0.
- ④ b6: RQS bit
When one of bits 0, 1 and 4 is 1, this bit is set to 1.
When all of bits 0, 1 and 4 are 0, it is cleared to 0.

(2) Limit operation and status byte

① Limit bit (bit 0)

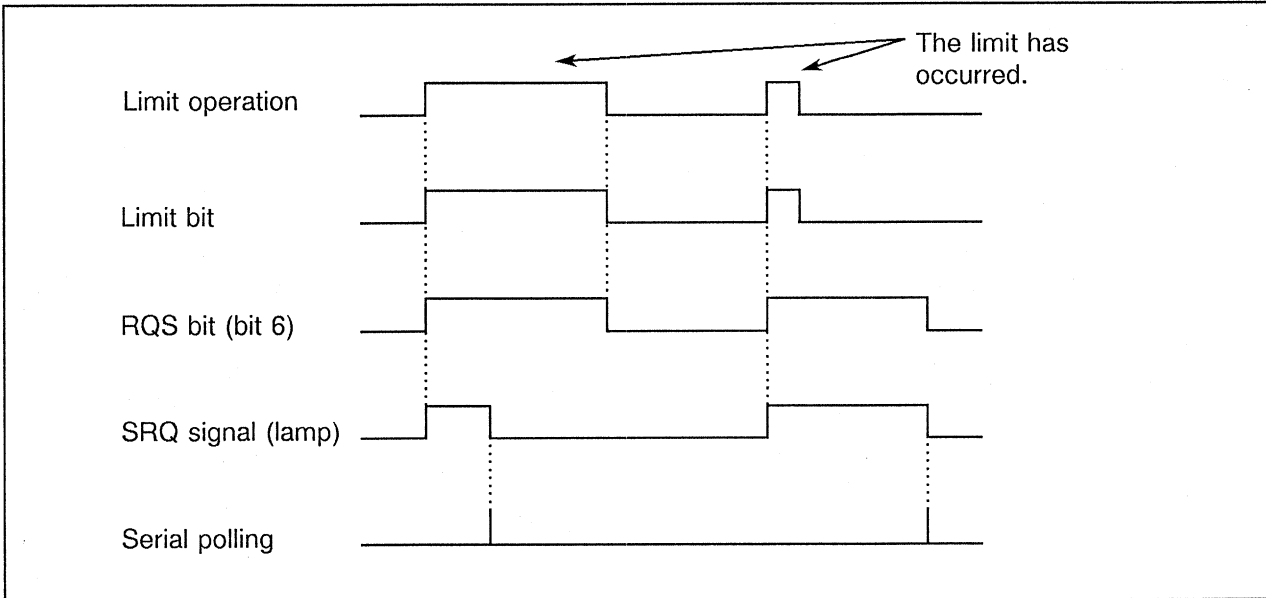

Figure 4-9 Timing of Limit Bit (TR6120A mode)

4.7.3 Service Request (SRQ)

When the Generator has been set in the S0 mode and when the RQS bit of the status byte is set to 1, the Generator sends an SRQ single line signal to notify it to the GPIB controller. The SRQ is cleared during serial polling by the controller.

4.8 Programming Examples

4.8.1 Programming Notes

If the unit and various codes are mixed in a program, they must be separated from each other by a comma (,).

Example 1:

(Incorrect) OUTPUT 708; "V7D10V6"

Error (ignored)

The addition of unit "V" is recognized and, therefore, the Auto Range is selected and the 10 V output of the 10 V range is set.

(Correct) OUTPUT 708; "V7D10,V6"

100 V range is set.

10 V output in 1000 V range

Example 2:

* "V4D + 0 V VL100IL20" also causes an error.

(Incorrect) OUTPUT 708; "V4D + 0VL100IL20"

Error (Err G01)

Auto Range (1 V range) + 0 V output

(Correct) OUTPUT 708; "V4D + 0,VL100IL20"

The voltage/current limit is set.
(100 V/20 mA)

The unit and codes are distinguished.

1 V range + 0 V output

The range is fixed during memory data input.

Example 3:

(Incorrect) OUTPUT 708; "MEM00, V5, D10V, VL20, IL100"

Error (Err G07)
The fixed range is set in the
Memory mode.

"MEM00, V 5, D10" (in abbreviated format) is entered.

(Correct) OUTPUT 708; "MEM00, V5, D10, VL20, IL100"

The voltage/current limit is set.
(20 V/100 mA)

10 V range, 10 V output data

4.8.2 Sample Programs (for HP200 Series)

Example 1: A programming example to generate the DC voltage

Generation voltage:	+ 30 V (100 V range)
Voltage limit:	50 V
Current limit:	20 mA
Sense status:	External sense
Guard status:	External guard

(1) Explanation of program

80	Clears the interface.
90	Enables remote control.
110	Defines the R6161 address of 8.
120	Initializes the GPIB interface device.
130	Sets the R6161 parameters as follows. V6: 100 V range of voltage generation VL50: 50 V voltage limit IL20: 20 mA current limit SEN1: External sense GRD1: External guard
140	Sets the R6161 generation value as follows. D + 30: 30 V
150	Sets the R6161 output to ON.
160	Specifies the wait time of several seconds.
170	Sets the R6161 output to OFF.
180	Specifies the wait time of several seconds.
190	End of program

(2) Programming example

```
10 ! *****
20 ! *
30 ! * R6161 SAMPLE PROGRAM 1 *
40 ! *
50 ! *****
60 !
70 !
80 ABORT 7
90 REMOTE 7
100 !
110 R6161=708
120 CLEAR R6161
130 OUTPUT R6161;"V6,VL50,IL20,SEN1,GRD1"
140 OUTPUT R6161;"D+30"
150 OUTPUT R6161;"E"
160 WAIT 5
170 OUTPUT R6161;"H"
180 WAIT 1
190 END
```

Example 2: A programming example to generate the DC voltage

Generation voltage:	From +0 V to +10 V at 0.01 V step (in 10 V range)
Voltage limit:	20 V
Current limit:	20 mA
Sense status:	External sense
Guard status:	External guard

R6161 PROGRAMMABLE REFERENCE
DC VOLTAGE/CURRENT GENERATOR
INSTRUCTION MANUAL

(1) Explanation of program

80 90 110	Clears the interface. Enables remote control. Defines the R6161 address of 8.
120	Initializes the GPIB interface device.
130 140 \ 150 160 170 180 190 200 210 220	Sets the R6161 parameters as follows. V5: 10 V range of voltage generation VL20: 20 V voltage limit IL20: 20 mA current limit SEN1: External sense GRD1: External guard Generates voltages from the initial value of 0 V to the last value of 10 V with the 0.01 V increment. Sets the R6161 generation value. Sets the R6161 output to ON (if the generation value is 0 V). Specifies the wait time of several seconds. Returns to line 140. Sets the R6161 output to OFF. Returns to line 140. End of program

(2) Programming example

```

10 ! *****
20 ! *
30 ! * R6161 SAMPLE PROGRAM 2 *
40 ! *
50 ! *****
60 !
70 !
80 ABORT 7
90 REMOTE 7
100 !
110 R6161=708
120 CLEAR R6161
130 OUTPUT R6161;"V5,VL20,IL20,SEN1,GRD1"
140 FOR I=0 TO 1000
150     DAT=I/100
160     OUTPUT R6161;"D+"&TRIM$(VAL$(DAT))
170     IF DAT=0 THEN OUTPUT R6161;"E"
180     WAIT 2
190 NEXT I
200 OUTPUT R6161;"H"
210 GOTO 140
220 END

```

Example 3: A programming example to measure the voltage generated by the Generator using a digital multimeter (DMM). The voltage is generated in the Program mode (step), and the output is measured on the DMM. Then, the end of measurement is received by the service request, the measured data is displayed, and the next setup is triggered by the controller. Also, the limit operation is received by the service request, and the output is allowed (in standby mode).

Scan channels:	Channels 00 to 09
Generation voltage:	100 V range
Setting output voltage:	-40 V to +40 V
Voltage limit:	20 V to 50 V
Current limit:	2 mA
Sense status:	Internal sense
Guard status:	Internal guard
DMM used:	TR6871
Measuring function:	DC voltage measurement
Measuring range:	200 V range
Trigger delay:	2 sec
Integration time:	5 PLC

(1) Explanation of program

70	Disables an SRQ reception.
80	Clears the interface.
90	Enables remote control.
110	Defines the R6161 address of 8.
120	Defines the TR6871 address of 2.
170	Initializes each parameter of the R6161.
180	Initializes each parameter of the TR6871.
190	Specifies the wait time of several seconds.
210	Specifies the first address of the subroutine for R6161 parameter setup.
220	Specifies the first address of the SRQ subroutine.
230	Sets the TR6871 parameters as follows.
	R6: 200 V range
	M1: Single Trigger in sampling mode
	H0: Header Off
	TD2000: 2-second trigger delay
	MS190: Masks status byte 190 (by issuing the service request when an output enable data generates).
	S0: Sends an SRQ signal.

**R6161 PROGRAMMABLE REFERENCE
DC VOLTAGE/CURRENT GENERATOR
INSTRUCTION MANUAL**

4.8 Programming Examples

(Cont'd)

240	<p>Sets the R6161 parameters as follows.</p> <p>ST2: Specifies the Step Scan in the Recall mode.</p> <p>SC00,09: Specifies to scan channels 00 to 09.</p> <p>*SRE65: Masks status byte 65 (by issuing the service request during limit operation).</p> <p>S0: Sends an SRQ signal.</p>
250	Recalls channel 00 of the R6161 memory.
260	Enables an SRQ reception.
270	Sets the R6161 output to ON.
280	Starts the program.
290	Sends a trigger signal to the TR6871 (to start measurement).
320	Sets the WAITF variable to 0.
330	Terminates the sample program if a service request is received from the R6161.
340	Jumps to line 280 if a service request is received from the TR6871.
350	Repeats executing lines 330 to 350 until a service request is received.
360	Terminates the sample program.
380	Specifies the subroutine name for parameter setup.
390	Assigns each parameter to the array variable and sets them in channels 00 to 09 of memory.
420	{
430	Returns to the main routine.
450	Specifies the subroutine name for service request processing.
460	Reads the status byte by polling the R6161.
470	Reads the status byte by polling the TR6871.
480	Executes processing of line 510 if the R6161 sends a service request.
490	Executes processing of line 550 if the TR6871 sends a service request.
510	Executes SRQ processing (of lines 520 and 530) of the R6161.
520	Sets the R6161 output to OFF.
530	Indicates the startup of limit operation.
540	Terminates SRQ processing of the R6161 (and jumps to line 590).
550	Executes SRQ processing of the TR6871 (of lines 560 and 570).
560	Reads the measured values.
570	Displays the measured values.
630	Enables an SRQ reception.
640	Sets the WAITF variable to 1.
650	Returns to the main routine.
670	Writes the data statement of each parameter.
710	}

(2) Programming example

```
10 ! *****
20 ! * *
30 ! * R6161 SAMPLE PROGRAM 3 *
40 ! * *
50 ! *****
60 !
70 DISABLE INTR 7
80 ABORT 7
90 REMOTE 7
100 !
110 R6161=708
120 TR6871=702
130 !
140 !
150 !
160 !
170 OUTPUT R6161;"Z"
180 OUTPUT TR6871;"Z"
190 WAIT 3
200 !
210 GOSUB DAT_SET
220 ON INTR 7 GOSUB S_POLL
230 OUTPUT TR6871;"R6,M1,H0,TD2000,MS190,S0"
240 OUTPUT R6161;"ST2,SC00,09,SMS65,S0"
250 OUTPUT R6161;"RCL00"
260 ENABLE INTR 7;2
270 OUTPUT R6161;"E"
280 OUTPUT R6161;"STT"
290 OUTPUT TR6871;"E"
300 !
310 !
320 WAITF=0
330 IF WAITF=1 AND S1<>0 THEN 360
340 IF WAITF=1 AND S1=0 THEN 280
350 GOTO 330
360 STOP
370 !
380 DAT_SET: !*****
390     FOR I=0 TO 9
400         READ DAT$(I)
410         OUTPUT R6161;"MEM"&VAL$(I)&" ,V6,"&DAT$(I)
420     NEXT I
430 RETURN
440 !
450 S_POLL: !*****
```

R6161 PROGRAMMABLE REFERENCE
DC VOLTAGE/CURRENT GENERATOR
INSTRUCTION MANUAL

4.8 Programming Examples

(Cont'd)

```
460     S1=SPOLL(R6161)
470     S2=SPOLL(TR6871)
480     IF S1<>0 THEN 510
490     IF S1=0 THEN 550
500     !
510     !==== R6161 SRQ ====
520         OUTPUT R6161;"H"
530         DISP " = = = LIMIT = = = "
540         GOTO 590
550     !====TR6871 SRQ ====
560         ENTER TR6871;A$
570         DISP VAL(A$)
580     !
590     !
600     !
610     !
620     !
630     ENABLE INTR 7
640     WAITF=1
650     RETURN
660     !
670     DATA "D+0,VL10,IL2","D+10,VL20,IL2"
680     DATA "D+20,VL30,IL2","D+30,VL40,IL2"
690     DATA "D+40,VL50,IL2","D-0,VL10,IL2"
700     DATA "D-10,VL20,IL2","D-20,VL30,IL2"
710     DATA "D-30,VL40,IL2","D-40,VL50,IL2"
720     !
730     END
```

Example 4-1: A programming example to read the setting parameters. Specify each parameter for the R6161, and read and display these parameters.

Parameters to be set and read:

- Generation voltage/current range
- Setting output value
- Voltage limit
- Current limit
- Sense status
- Guard status
- Output status

(1) Explanation of program and output data

80	Clears the interface.
90	Enables remote control.
110	Defines the R6161 address of 8.
120	Initializes each parameter of the R6161.
140	Specifies the first address of the subroutine for parameter setup.
150	Repeats the parameter setup, read, and display sequence 10 times.
160	Sets the parameters for the R6161.
170	Sends the Query command of sense status to the R6161.
180	Reads the parameters of the R6161 sense status.
190	Sends the Query command of guard status to the R6161.
200	Reads the parameters of the R6161 guard status.
210	Sends the Query command of each parameter (generation voltage/current range, setting output value, voltage limit, current limit, and output status) to the R6161.
230	Reads all R6161 parameters simultaneously.
240	Jumps to the line which delimits parameters by a comma and displays them if processing is repeated 5 to 9 times.
250	Extracts the generation voltage/current range parameters from the batch read parameters.
260	Extracts the setting output value parameter from the batch read parameters.
270	Extracts the voltage limit parameter from the batch read parameters.
280	Extracts the current limit parameter from the batch read parameters.
290	Extracts the output status parameter from the batch read parameters.
300	Displays each parameter by delimiting it with a space.
}	
310	
320	Jumps to line 340 if processing is repeated 0 to 4 times.
330	Displays each parameter by delimiting it with a comma.
340	Repeats processing from line 150.
350	Program end
370	Specifies the subroutine name for parameter setup.

R6161 PROGRAMMABLE REFERENCE
DC VOLTAGE/CURRENT GENERATOR
INSTRUCTION MANUAL

4.8 Programming Examples

(Cont'd)

380	Assigns each parameter to the array variable.
}	
400	Returns to the main routine.
410	
430	
}	Specifies the data statement of each parameter.
520	

Output data

V4	D+0.000000	V	VL0090	IL003	SB	SEN1	GRD0
V7	D+1199.000	V	VL1250	IL013	SB	SEN1	GRD1
V4	D+1.000000	V	VL0100	IL010	OP	SEN1	GRD1
V5	D-11.23450	V	VL0050	IL005	SB	SEN1	GRD1
V6	D+050.0000	V	VL0070	IL070	OP	SEN0	GRD1
I2,	D-05.55500MA,	VL0100,	IL012,	SB,	SEN0,	GRD0	
I3,	D+030.5000MA,	VL0120,	IL050,	SB,	SEN0,	GRD1	
V2,	D+05.01000MV,	VL0020,	IL010,	OP,	SEN0,	GRD1	
V3,	D-011.0000MV,	VL0020,	IL010,	OP,	SEN0,	GRD1	
V9,	D+0500.300MV,	VL0020,	IL010,	SB,	SEN0,	GRD1	

(2) Programming example

```

10 ! *****
20 ! * *
30 ! * R6161 SAMPLE PROGRAM 4-1 *
40 ! * *
50 ! *****
60 !
70 DIM DAT$(10)[50],PANE$(50)
80 ABORT 7
90 REMOTE 7
100 !
110 R6161=708
120 OUTPUT R6161;"Z"
130 !
140 GOSUB DAT_SET
150 FOR I=0 TO 9
160     OUTPUT R6161;DAT$(I)
170     OUTPUT R6161;"SEN?"
180     ENTER R6161;SEN$
190     OUTPUT R6161;"GRD?"
200     ENTER R6161;GRD$
210     OUTPUT R6161;"PANE?"
220     !
230     ENTER R6161;PANE$
240     IF I>4 THEN 330
250     RANGE$=PANE$[1,2]
260     SET_DAT$=PANE$[4,15]
270     V_LIMIT$=PANE$[17,22]
280     I_LIMIT$=PANE$[24,28]
290     OUTPUT$=PANE$[30,31]
300     PRINT RANGE$;" ";SET_DAT$;" ";V_LIMIT$;" ";I_LIMIT$;" ";
        OUTPUT$;
310     PRINT " ";SEN$;" ";GRD$
320     GOTO 340
330     PRINT PANE$;" ";SEN$;" ";GRD$
340 NEXT I
350 STOP
360 !
370 DAT_SET:! *****
380     FOR I=0 TO 9
390         READ DAT$(I)
400     NEXT I
410     RETURN
420 !
430 DATA "V4,D+0,VL90,IL3,SEN1,GRD0,SB"

```

R6161 PROGRAMMABLE REFERENCE
DC VOLTAGE/CURRENT GENERATOR
INSTRUCTION MANUAL

4.8 Programming Examples

(Cont'd)

```
440 DATA "V7,D+1199,VL1250,IL30,SEN1,GRD1,SB"  
450 DATA "V4,D+1,VL100,IL10,SEN1,GRD1,OP"  
460 DATA "V5,D-11.2345,VL50,IL5,SEN1,GRD1,SB"  
470 DATA "V6,D+50,VL70,IL70,SEN0,GRD1,OP"  
480 DATA "I2,D-5.555,VL100,IL12,GRD0,SB"  
490 DATA "I3,D+30.5,VL120,IL50,GRD1,SB"  
500 DATA "V2,D+5.01,GRD1,OP"  
510 DATA "V3,D-11.25,GRD0,OP"  
520 DATA "V9,D+500.3,GRD1,SB"  
530 !  
540 END
```

Example 4-2: A programming example to read the setting parameters
Store each parameter in the R6161 memory, and read and display these parameters.

Memory used for storage and readout:

Setup: Channels 10 to 16
Readout: Channels 10 to 13 ("MEM X ?" is used.)
Channels 14 to 16 ("MEM X,Y ?" is used.)

Parameters to be set and read:

Generation voltage/current range
Setting output value
Voltage limit
Current limit

(1) Explanation of program and output data

70	Assigns the array of setting parameter variables and Query response variables.
80	Clears the interface.
90	Enables remote control.
110	Defines the R6161 address of 8.
120	Initializes each parameter of the R6161.
140	Specifies the first address of the subroutine for parameter setup.
150	Reads memory data from channels 10 to 13 using the Query command and displays them.
160	Sends the Query command to read data from the specified memory.
170	Reads data from the specified memory.
180	Displays data of the specified memory.
190	Repeats processing from line 150.
200	Sends the Query command to read memory data from channels 14 to 16.
210	Reads memory data from channels 14 to 16 simultaneously.
230	Displays the batch read data.
240	Program end
260	Specifies the subroutine for parameter setup.
270	Stores each parameter in channels 10 to 16.
}	
300	
310	Returns to the main routine.
330	Specifies the data statement of each parameter.
}	
390	

Output data

```
MEM10,V4,D+0.000000 V,VL0090,IL003
MEM11,V7,D+1199.000 V,VL1250,IL013
MEM12,V4,D+1.000000 V,VL0100,IL010
MEM13,V5,D-11.23450 V,VL0050,IL005

MEM14,V6,D+050.0000 V,VL0070,IL070;MEM15,I2,D-05.55500MA,VL0100,IL012;
MEM16,I3,D+030.5000MA,VL0120,IL050
```

(2) Programming example

```
10 ! *****
20 ! * *
30 ! * R6161 SAMPLE PROGRAM 4-2 *
40 ! * *
50 ! *****
60 !
70 DIM DAT$(100)[50],PARA$(50),MEM_DAT$(200)
80 ABORT 7
90 REMOTE 7
100 !
110 R6161=708
120 OUTPUT R6161;"Z"
130 !
140 GOSUB DAT_SET
150 FOR I=10 TO 13
160     OUTPUT R6161;"MEM"&TRIM$(VAL(I))&"?"
170     ENTER R6161;PARA$
180     PRINT PARA$
190 NEXT I
200 OUTPUT R6161;"MEM14,16?"
210 ENTER R6161;MEM_DAT$
220 PRINT
230 PRINT MEM_DAT$
240 STOP
250 !
260 DAT_SET: ! *****
270     FOR I=10 TO 16
280         READ DAT$(I)
290         OUTPUT R6161;"MEM"&TRIM$(VAL$(I))&" "&DAT$(I)
300     NEXT I
310 RETURN
320 !
330 DATA "V4,D+0,VL90,IL3"
340 DATA "V7,D+1199,VL1250,IL30"
350 DATA "V4,D+1,VL100,IL10"
360 DATA "V5,D-11.2345,VL50,IL5"
370 DATA "V6,D+50,VL70,IL70"
380 DATA "I2,D-5.555,VL100,IL12"
390 DATA "I3,D+30.5,VL120,IL50"
400 !
410 END
```

5. BCD REMOTE CONTROL AND INPUT SIGNALS (EXTERNAL TRIGGER)

5.1 Outline of BCD Remote Control

The Generator can parallelly control the following five functions via the 50-pin remote control connector locating on its rear panel.

- (1) Output value setup (in 10^0 to 10^6 digits)
- (2) Switching of voltage, current, and divider (10 mV, 100 mV, or 1000 mV) functions
- (3) Polarity switching
- (4) Limit level setup
- (5) Switching between Operate and Standby modes

The Generator can output the following two types of control signals.

- (1) Limiter signal when the limiter is activated in the Operate mode
- (2) Operate signal indicating the current signal output

These signals may also be output even when the Generator is not in the remote control.

CAUTION

Difference from the TR6120A:

The Generator has the divider on/off switching function at pin 38 of the 50-pin connector (See Table 5-1).

5.2 Preparation and Notes on BCD Remote Control

(1) Preparation

Turn the POWER switch off, and connect the REMOTE cable between the Generator and an external device.

As the Amphenol's 57-40500 connector is used, you must prepare an appropriate signal cable.

The optional Advantest's MO-01 cable is also available.

(2) Notes

CAUTION

1. Once the Remote Control mode is selected, the setting is backed up until it is released. (See Section 5.3).
2. When the Remote Control mode is released (that is, when signal at pin 50 is set to high or open), the previous display and output appear again.
3. The GPIB interface does not function during BCD remote control.

5.3 Selection of BCD Remote Control

Select the Remote Control mode using the LOCAL and ENTER keys as follows.

Procedure:

- ① Press the LOCAL key to display the GPIB address and GPIB operation mode (R6161-TR6120A) status.

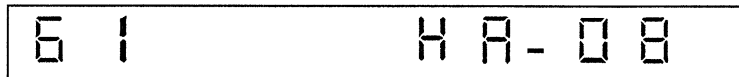

- ② Press the LOCAL key to display the BCD setup message.

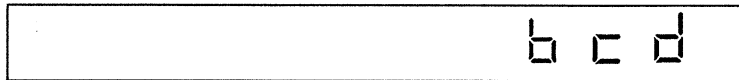

- ③-1 Press the ENTER key. The BCD Remote Control mode will be selected, the BCD data will be displayed, and the REMOTE lamp will light.

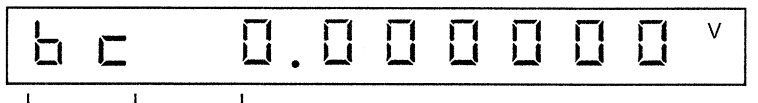

"1 V Zero" is displayed when the signal of Remote Control input line is high (without cable connection).

Indicates that the BCD Remote Control mode has been selected.

- ③-2 To select the normal mode, press the LOCAL key without pressing the ENTER key. The Normal Input, GPIB Address, and BCD modes are selected one after the

other whenever you press the LOCAL key as follows.

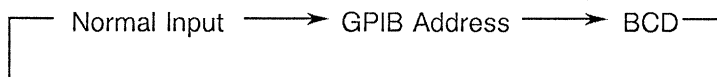

CAUTION

Once the Remote Control mode is selected, the BCD Remote Control mode is backed up. To release it, press the [LOCAL] key.

5.4 Interface Functions

Table 5-1 lists the Remote Control connector functions.

Table 5-1 Remote Control Connector Functions

Control function	BCD	Pin No.	Pin No.	BCD	Control function
COMMON		1	26	A	10 ⁶
Level 10 ⁰ (lowest digit)	A	2	27		
	B	3	28		
	C	4	29		
	D	5	30		
10 ¹	A	6	31		NC
	B	7	32		
	C	8	33		
	D	9	34	A	
10 ²	A	10	35	B	RANGE
	B	11	36	C	
	C	12	37	D	POLARITY
	D	13	38		DIVIDER
10 ³	A	14	39		
	B	15	40		LIMIT CONTROL
	C	16	41	A	V. LIMIT
	D	17	42	B	
10 ⁴	A	18	43	A	I. LIMIT
	B	19	44	B	
	C	20	45		NC
	D	21	46		LIMIT FLAG OUT
10 ⁵	A	22	47		REMOTE OP. IN
	B	23	48		OP. FLAG OUT
	C	24	49		NC
	D	25	50		NC

- Connectors used
 Amphenol's 57-40500 (at Generator side)
 Amphenol's 57-30500 (at cable end)

**R6161 PROGRAMMABLE REFERENCE
DC VOLTAGE/CURRENT GENERATOR
INSTRUCTION MANUAL**

5.4 Interface Functions

NC

No
connection

Pin 34 ————— V.I MODE
 V = "0"
 I = "1"

35, 36 ————— RANGE

RANGE	C	B
10 mV, 1 V, 1 mA	0	0
100 mV, 10 V, 10 mA	0	1
1000 mV, 100 V, 100 mA	1	0
1000 V	1	1

37 ————— POLARITY
 + = "0"
 - = "1"

38 ————— DIVIDER
 ON = "1"
 OFF = "0"

41, 42 ————— V.LIMIT

	B	A
10 V	0	0
130 V	0	1
300 V	1	0
1250 V	1	1

43, 44 ————— I.LIMIT

	B	A
5 mA	0	0
13 mA	0	1
50 mA	1	0
125 mA	1	1

48 ————— OPERATE FLAG OUT
 OP = "1"
 ST-BY = "0"

47 ————— REMOTE
 OP = "1"

5.5 Electrical Characteristics of Signals

Figure 5-1 provides the electrical characteristics of Generator signals. The negative logic is used for remote control (that is, the low level signal is logical 1, and high level signal is logical 0).

Signal direction	Internal circuit and rating of Generator	Signal name
Input to generator	<p>High level (logical "0") : 3.5 VDC to 5.25 VDC Low level (logical "1") : 0 VDC to 1 VDC</p> 	<p>OUTPUT LEVEL V/I MODE RANGE POLARITY DIVIDER V-LIMIT I-LIMIT OPERATE/STANDBY</p>
Output to peripherals	<p>High level output voltage : 2.7 VDC MIN High level output current : 400 μA MAX Low level output voltage : 0.5 VDC MAX Low level output current : -8 mA MAX</p> 	<p>LIMIT FLAG OP. FLAG</p>

Figure 5-1 Electrical Characteristics of Signals

5.6 External Trigger Input Signals

Use the external trigger input signals to start (or pause) the Generator in the Scan mode (this function is the same as the START key on the front panel).

The electrical characteristics are as follows.

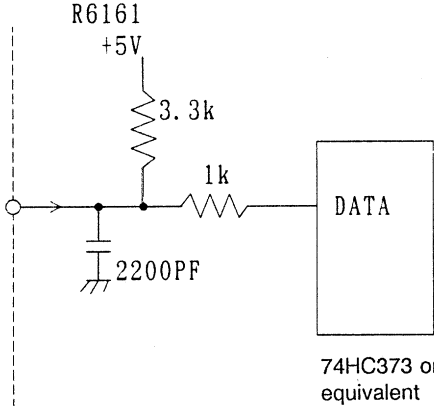
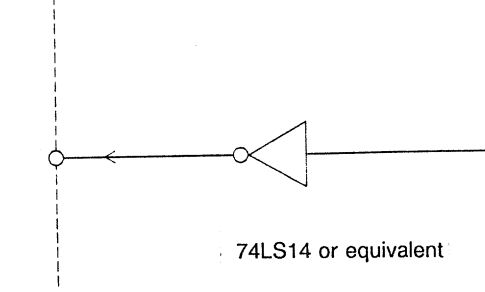
- Signals: Negative logic
(The low level signal is logical 1, and the high level signal is logical 0.)
- Input signal level
High level: 2.1 to 5.25 VDC
Low level: 0 to 0.7 VDC
Pulse width: 10 μ sec or more
- Internal circuit

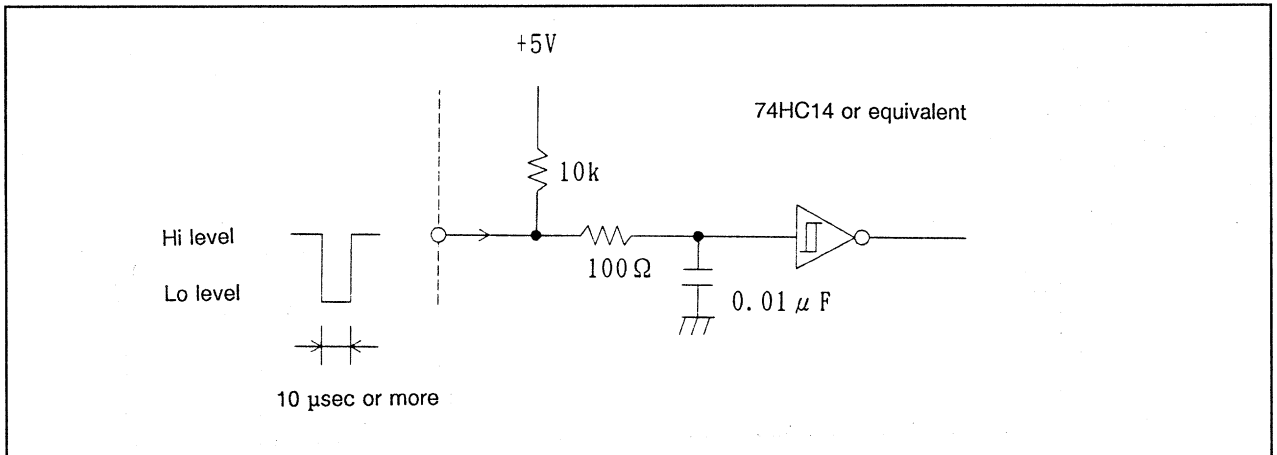

- Connector : Hirose's BNC-071 or equivalent

6. OPERATION PRINCIPLE

6.1 Operations and Block Diagram

Figure 6-1 shows the block diagram of the Generator.

The Generator consists of four major functional blocks: Data Setup block, Reference block, Amplifier block, and External I/O block. This section explains the Generator when it operates in the following sequence.

- ① Analyze data entered from the display key switch of the Data Setup block or from the GPIB or BCD remote control of the External I/O block.
- ② Set the analyzed data (corresponding to the output voltage) in the pulse width control block.
- ③ Drive the pulse width generator of the Reference block from the pulse width control block and chops the reference voltage. The chopped voltage is passed through the low-pass filter and converted into the DC voltage.
Also, the function range and polarity data are sent to the Reference block and Amp block via the I/O block.
- ④ Sends the voltage generated by the Reference block to the error amp of the Amp block. This voltage is passed through the output buffer, and the 1 μ V to 1000 V, 1 nA to 100 mA voltages and current are output. Also, the 10 nV to 1000 mV voltages are output via the divider block.

The Data Setup, Reference, and Amp blocks are explained in Sections 6.2, 6.3, and 6.4, respectively.

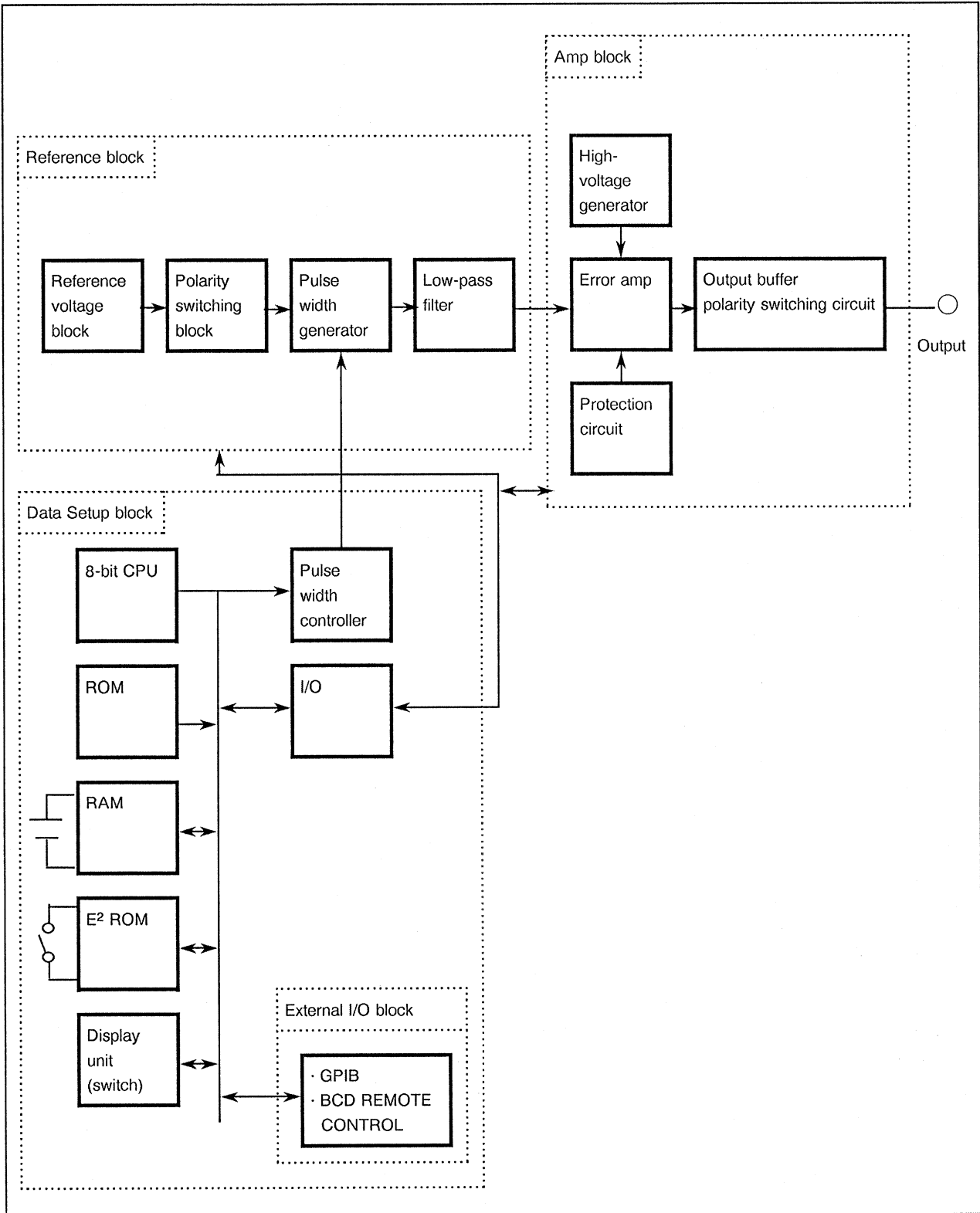

Figure 6-1 Block Diagram

6.2 Data Setup Block

The Data Setup block is the core of the Generator control section. Your Generator is controlled by the 8-bit CPU (Central Processing Unit).

The CPU controls the following five major operations.

- (1) Display and key switch operations
- (2) Driving of pulse width control block to determine the output voltage
- (3) Driving of I/O block for function, range, and polarity setup
- (4) External I/O operations (GPIB and BCD remote control)
- (5) Storage of calibration data (into electrically writable ROM)

6.3 Reference Block

Figure 6-3 shows the time-division voltage divider system that the Generator uses. When the switch (SW) is turned on or off with times T_1 and T_2 in this figure, the voltage waveforms at point \textcircled{A} can appear as shown in Figure 6-4.

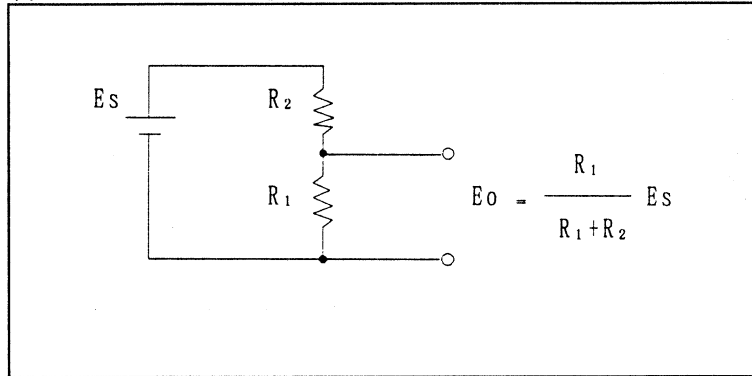

Figure 6-2 Resistance Divider

When this pulse voltage is passed through the filter of R and C , output E_o will be as follows:

$$E_o = \frac{T_1}{T_1 + T_2} E_s = \frac{T_1}{T} E_s$$

This equation corresponds to the resistance divider shown in Figure 6-2. That is, E_s is divided by the duty of square waves ($T_1:T_2$).

The Generator changes this square wave duty according to the setup, and uses the corresponding reference voltage.

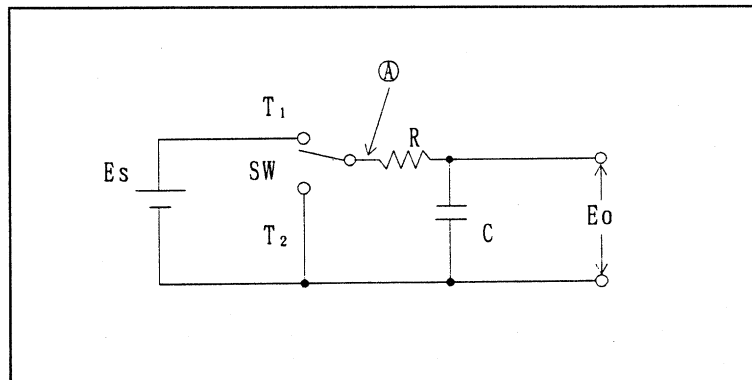

Figure 6-3 Voltage Dividing by Time Division

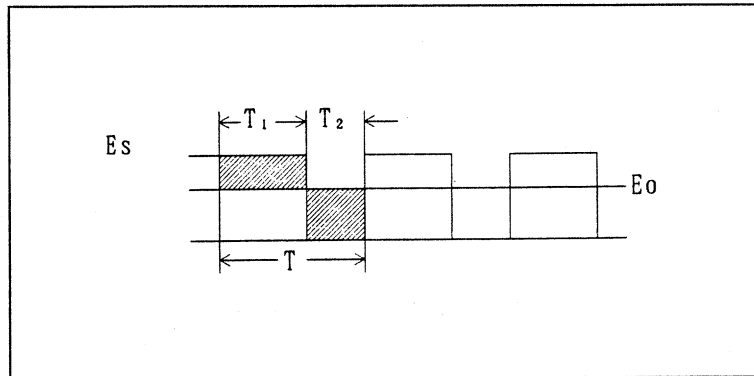

Figure 6-4 Voltage Waveforms at Point A

6.4 Amp Block

The Generator has the amplifier unit featuring the constant voltage and current outputs as shown in the following figures. For constant voltage output, the current is feed back at the operational amp and it becomes as follows.

$$E_o = - \frac{R_f}{R_i} E_{ref}$$

The range is switched by changing "Rs" and "Rf" values, and the signal level is set by "Eref". As up to 1200V voltage is output at the output stage of "A0" error amp, the Amp block has the built-in power supply appropriate to this output. The amp at the input stage uses an FET chopper stabilized amp.

Figure 6-7 shows the configuration of amp and its fixed current is as follows.

$$I_o = \frac{R_c + R_s}{R_i \times R_s} E_{ref}$$

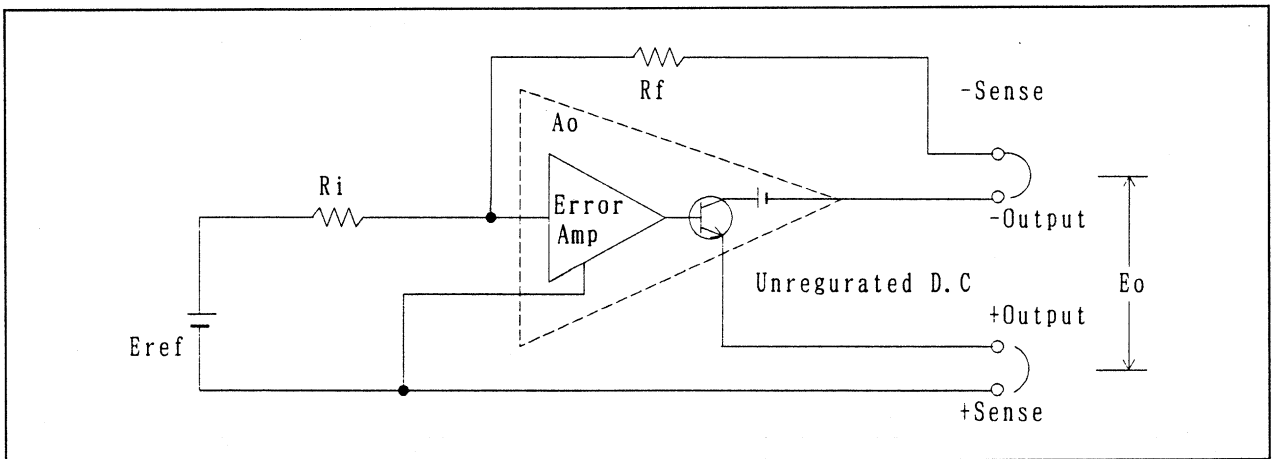

Figure 6-6 Voltage Generator Circuit

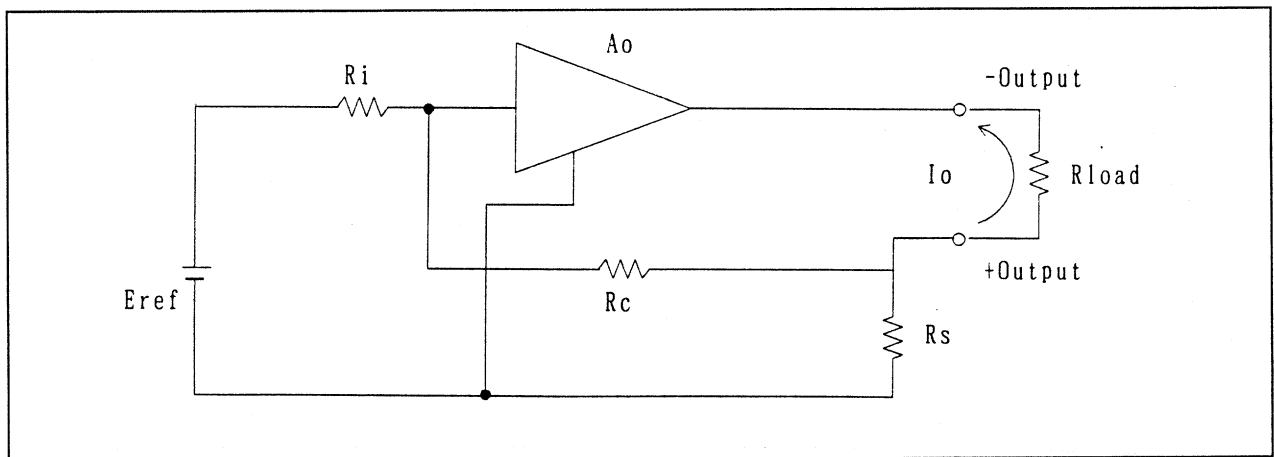

Figure 6-7 Current Generator Circuit

7. CALIBRATION

You must calibrate your Generator once every three months or six months to keep the signal generation accuracy defined in Chapter 8.

7.1 Before Calibration

7.1.1 Instruments Required

Use the recommended instruments listed on Table 7-1 or those having the higher specifications for the calibration.

Table 7-1 Instruments Required for Calibration

External standard	Operating range	Accuracy	Recommended instrument
Digital voltmeter	1 μ V to 1000 V	Within ± 0.001 %	TR6871 + TR68701 (*1)
	10 nV to 1 V	Within ± 0.004 %	
Digital current meter (*2)	1 nA to 100 mA	Within ± 0.003 %	

*1 The TR6871 and TR68701 must be calibrate on a high accuracy standard and calibrated within one day after it.

*2 If the high accuracy Digital current meter is unavailable, use a shunt resistor and calculate the result on a digital voltmeter. Advantest also uses this measuring method.

Shunt resistors:	10 Ω	-	100 mA	}	Calibrated
	100 Ω	-	10 mA		
	1 k Ω	-	1 mA		

7.1.2 Before Calibration

(1) Calibration conditions

- Ambient temperature range: +23°C ± 1°C (fixed)
- Humidity: 60% or less (relative)
- Source voltage variation: 100 VAC ± 10%, 50/60 Hz
- Calibration location: Free from excessive EMI interference, electrostatic induction interference, dusts, vibration and mechanical shock

(2) Warmup (preheating time)

The external standard must be warmed up for the specified time period before calibration. The Generator must also be warmed up as follows.

- If the Generator is moved from the normal temperature (+18 to +28°C) to the calibration chamber;
Place the Generator two hours in the chamber and preheat it one hour or more.
- If the Generator is moved from the low temperature (below +18°C) to the calibration chamber;
Place the Generator two hours in the chamber and preheat it two hours or more.

CAUTION

The humidity may increase during preheating and water condensing may result. You must dry the Generator and start calibration.

- If the Generator is moved from the high temperature (above +28°C) to the calibration chamber ;
Place the Generator two hours in the chamber and preheat it two hours or more.

(3) Calibration period

The Generator must be calibrated every three months or six months. However, if you use your Generator in the specifications defined in Chapter 8, you must calibrate it each time when you use it. Generally, you can satisfy the Generator standards if you calibrate it every three months.

7.1.3 Calibration Notes

- (1) Calibrate your Generator in the sequence of voltage functions (including divider), current functions, voltage limiter, and current limiter.
- (2) Use a copper clip for cable connection as the voltage sensitivity may reach 10 nV during divider output. To minimize an affect by the thermoelectromotive force, place your Generator one minute or more after cable connection and start calibration.

7.2 Calibration

7.2.1 Flowchart of Calibration Procedure

Figure 7-1 shows a flowchart of standard calibration procedure.

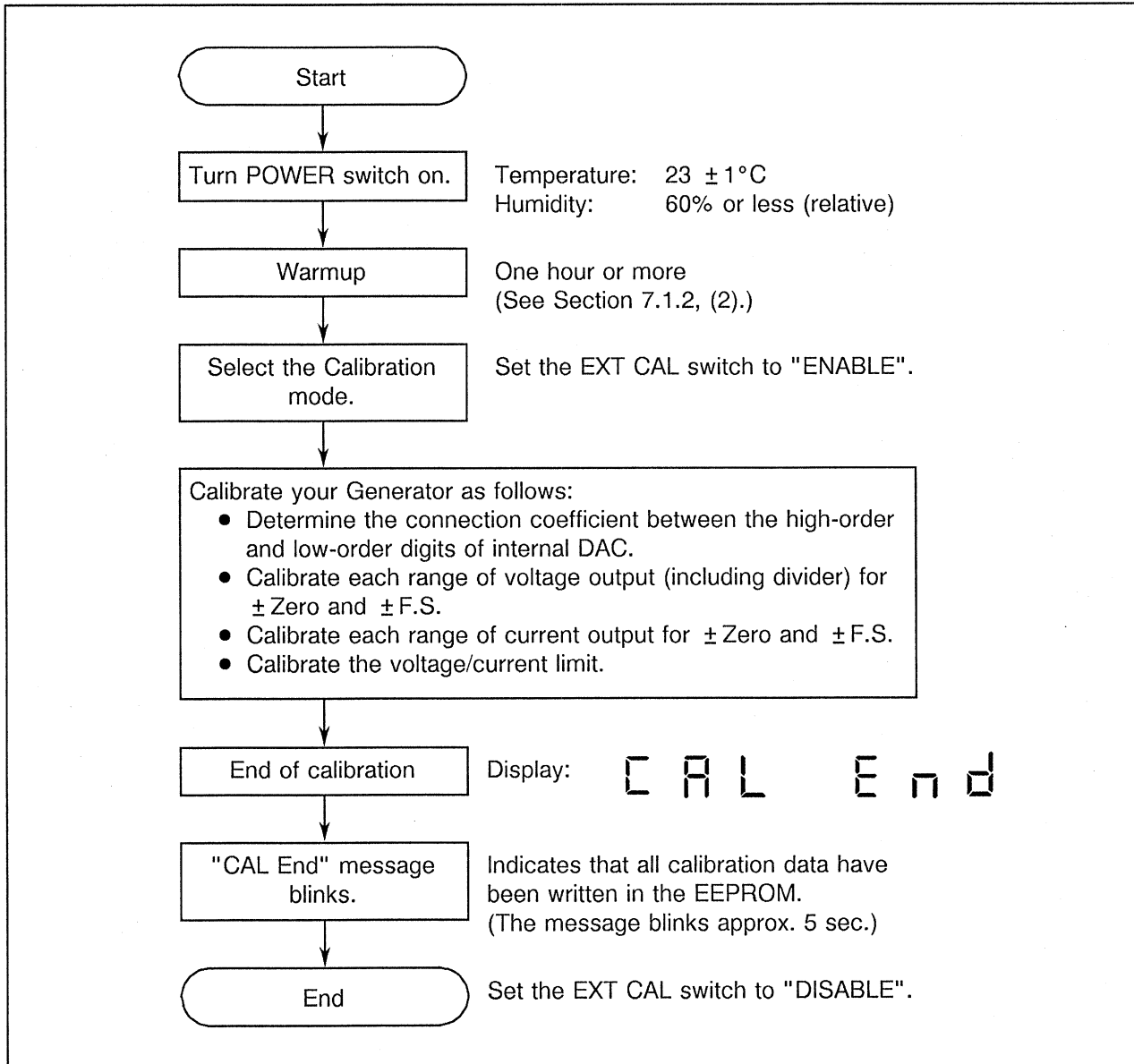
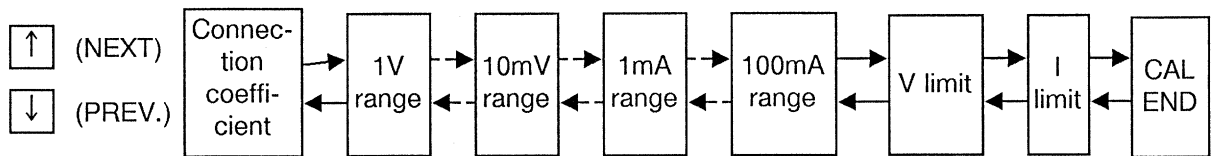

Figure 7-1 Flowchart of Calibration Procedure

7.2.2 Calibration Procedure

before the Calibration Procedure

1. Switch each range using the or key.







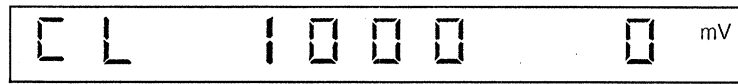

2. To cancel data during its entry (the data blinks during entry), press the key.
3. If the power fails during calibration, restart from the interrupted range.
4. When you set CAL END (end of calibration), the calibration data is written in the EEPROM.
5. You must always calibrate for each range in the sequence of "+ Zero → + F.S → - Zero → - F.S".
6. Calibrate the Generator in a pair of "+ Zero" and "+ F.S" and a pair of "- Zero" and "- F.S". If you recalibrate "Zero", you must recalibrate "F.S" again.
7. Set the integration time of 20 PLC or more on the digital voltmeter and use it.
8. Set the settling time of approximately 5 seconds after output generation (except for the 1000 V range).

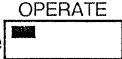
(4) Calibration in 1 V range



(CAL 1 V range Zero output)

- ① Press the  key, measure the generation voltage (Zero output) on the DMM (in 1 μ V resolution), and enter data from the entry key section.
 (Enter data in units of mV (displayed on the panel).)







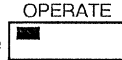

For example, press keys      and  in this sequence.

- ② Press the  key.



(CAL 1 V range F.S output)

- ③ Press the  key, measure the generation voltage (F.S output) on the DMM (in 1 μ V resolution), and enter data from the entry key section.
 (Enter data in units of mV (displayed on the panel).)







For example, press keys        and  in this sequence.

- ④ Press the  key.



(CAL 1 V range -Zero output)

- ⑤ Press the  key, measure the generation voltage (-Zero output) on the DMM (in 1 μ V resolution), and enter data from the entry key section.
 (Enter data in units of mV (displayed on the panel).)

For example, press keys      and  in this sequence.
 (-)

- ⑥ Press the key.

CL	1000	-F5	mV
(CAL	1 V range	-F.S output)	

- ⑦ Press the key, measure the generation voltage (–F.S output) on the DMM (in 1 μ V resolution), and enter data from the entry key section.
(Enter data in units of mV (displayed on the panel).)

For example, press keys and in this sequence.
(-)





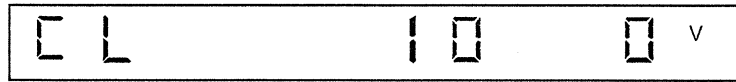

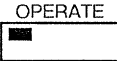

- ⑧ Press the key.

(5) Calibration for 10 V range



(CAL 10 V range Zero output)

- ① Press the  key, measure the generation voltage (Zero output) on the DMM (in 1 μ V resolution), and enter data from the entry key section.
(Enter data in units of V)





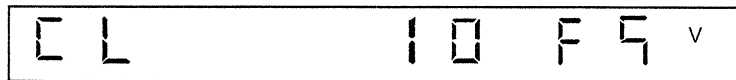

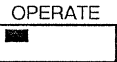

For example, press keys         and  in this sequence.

- ② Press the  key.



(CAL 10 V range F.S output)

- ③ Press the  key, measure the generation voltage (F.S output) on the DMM (in 10 μ V resolution), and enter data from the entry key section.
(Enter data in units of V)





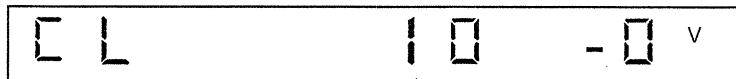



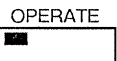

For example, press keys         and  in this sequence.

- ④ Press the  key.



(CAL 10 V range -Zero output)

- ⑤ Press the  key, measure the generation voltage (-Zero output) on the DMM (in 1 μ V resolution), and enter data from the entry key section.
(Enter data in units of V)

For example, press keys          and  in this sequence.
(-)

- ⑥ Press the key.

CL	10 - F 5 V
----	------------

(CAL 10 V range - F.S output)

- ⑦ Press the key, measure the generation voltage (-F.S output) on the DMM (in 10 μ V resolution), and enter data from the entry key section.
(Enter data in units of V)

For example, press keys and in this sequence.
(-)

The calibration for the 10 V range has been completed.

- ⑧ Press the key.







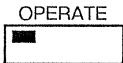

Switch to the 100 V range.

(6) Calibration for 100 V range



(CAL 100 V range Zero output)

- ① Press the  key, measure the generation voltage (Zero output) on the DMM (in 10 μ V resolution), and enter data from the entry key section.
 (Enter data in units of V)







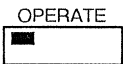

For example, press keys        and  in this sequence.

- ② Press the  key.



(CAL 100 V range F.S output)

- ③ Press the  key, measure the generation voltage (F.S output) on the DMM (in 100 μ V resolution), and enter data from the entry key section.
 (Enter data in units of V)





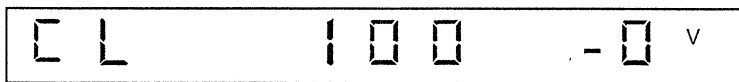



For example, press keys         and  in this sequence.

- ④ Press the  key.



(CAL 100 V range -Zero output)

- ⑤ Press the  key, measure the generation voltage (-Zero output) on the DMM (in 10 μ V resolution), and enter data from the entry key section.
 (Enter data in units of V)

For example, press keys         and  in this sequence.
 (-)

- ⑥ Press the key.

(CAL 100 V range -F.S output)

- ⑦ Press the key, measure the generation voltage (-F.S output) on the DMM (in 100 μ V resolution), and enter data from the entry key section.
(Enter data in units of V)

For example, press keys and in this sequence.
(-)

- ⑧ Press the key.



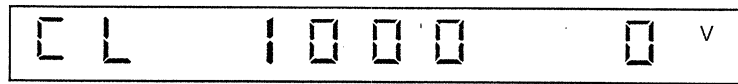

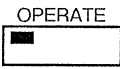

(7) Calibration for the 1000 V range



(CAL 1000 V range Zero output)

- ① Press the  key, ^(*) measure the generation voltage (Zero output) on the DMM (in 100 μ V resolution), and enter data from the entry key section.
 (Enter data in units of V)

*1: Use the data displayed approximately 20 seconds after the OPERATE operation.

For example, press keys       and  in this sequence.



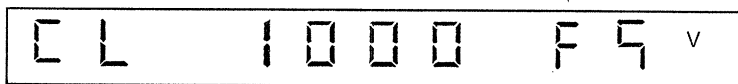



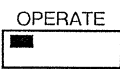

- ② Press the  key.



(CAL 1000 V range F.S output)

- ③ Press the  key, ^(*) measure the generation voltage (F.S output) on the DMM (in 1 mV resolution), and enter data from the entry key section.
 (Enter data in units of V)

*1: Use the data displayed approximately 20 seconds after the OPERATE operation.

For example, press keys         and  in this sequence.



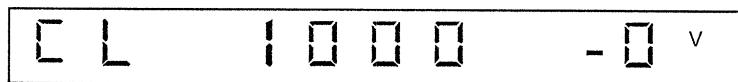



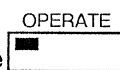

- ④ Press the  key.



(CAL 1000 V range - Zero output)

- ⑤ Press the  key, ^(*) measure the generation voltage (-Zero output) on the DMM (in 100 μ V resolution), and enter data from the entry key section.
 (Enter data in units of V)

*1: Use the data displayed approximately 20 seconds after the OPERATE operation.

For example, press keys        and  in this sequence.
 (-)

- ⑥ Press the key.

CL	1000	-FS	V
----	------	-----	---

(CAL 1000 V range -F.S output)

- ⑦ Press the key, (*1)measure the generation voltage (-F.S output) on the DMM (in 1 mV resolution), and enter data from the entry key section.

(Enter data in units of V)

*1: Use the data displayed approximately 20 seconds after the OPERATE operation.

For example, press keys and in this sequence.

(-)

The calibration for the 1000 V range has been completed.

- ⑧ Press the key.

Switch to the 10 mV range.

(8) Calibration for the 10 mV range (divider)

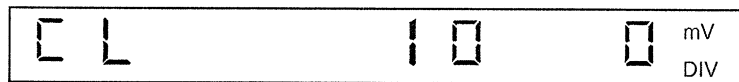









(CAL 10 mV range Zero output)

CAUTION

1. Use a copper clip for cable connection to the divider output terminals (Hi and Lo).
2. Calibrate the digital voltmeter to zero (in 10 nV resolution) before starting the Generator calibration.

- ① Press the  key, (*1) measure the generation voltage (Zero output) on the DMM (in 10nV resolution), and enter data from the entry key section.
(Enter data in units of mV.)

*1: When connecting then cable to the divider output terminals, wait for one minutes or more to avoid an affection by the thermoelectromotive force.

For example, press keys        and  in this sequence.

- ② Press the  key.

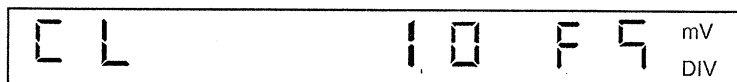

(CAL 10 mV range F.S output)

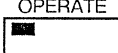
- ③ Press the  key, measure the generation voltage (F.S output) on the DMM (in 10 nV resolution), and enter data from the entry key section.
(Enter data in units of mV.)





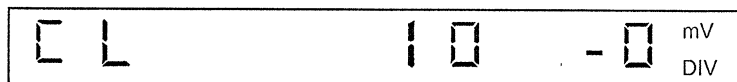



For example, press keys         and  in this sequence.

- ④ Press the  key.



(CAL 10 mV range -Zero output)









- ⑤ Press the  key, measure the generation voltage (–Zero output) on the DMM (in 10 nV resolution), and enter data from the entry key section.
(Enter data in units of mV.)

For example, press keys        and  in this sequence.
(-)

- ⑥ Press the  key.

CL	10	-F5	mV DIV
(CAL	10 mV range	-F.S output)	

- ⑦ Press the  key, measure the generation voltage (–F.S output) on the DMM (in 10 nV resolution), and enter data from the entry key section.
(Enter data in units of mV.)

For example, press keys         and  in this sequence.
(-)

The calibration for the 10 mV range has been completed.

- ⑧ Press the  key.





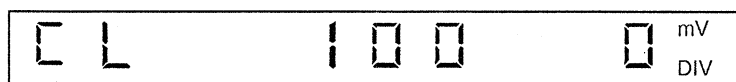

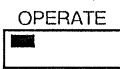

Switch to the 100 mV range.

(9) Calibration for the 100 mV range (divider)



(CAL 100 mV range Zero output)

- ① Press the  key, measure the generation voltage (Zero output) on the DMM (in 10nV resolution), and enter data from the entry key section.
 (Enter data in units of mV.)





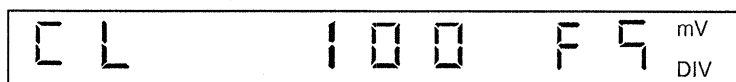

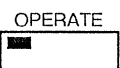

For example, press keys        and  in this sequence.

- ② Press the  key.



(CAL 100 mV range F.S output)

- ③ Press the  key, measure the generation voltage (F.S output) on the DMM (in 100nV resolution), and enter data from the entry key section.
 (Enter data in units of mV.)





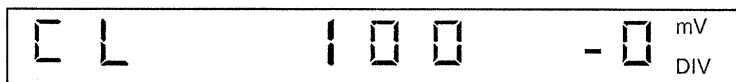



For example, press keys         and  in this sequence.

- ④ Press the  key.



(CAL 100 mV range -Zero output)

- ⑤ Press the  key, measure the generation voltage (-Zero output) on the DMM (in 10nV resolution), and enter data from the entry key section.
 (Enter data in units of mV.)

For example, press keys         and  in this sequence.
 (-)

- ⑥ Press the key.

CL	100	-FS	mV DIV
(CAL	100 mV range	-F.S output)	

- ⑦ Press the key, measure the generation voltage (–F.S output) on the DMM (in 100 nV resolution), and enter data from the entry key section.
(Enter data in units of mV.)

For example, press keys and in this sequence.
(-)

The calibration for the 100 mV range has been completed.

- ⑧ Press the key.





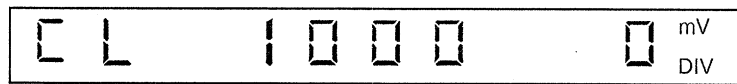

Switch to the 1000 mV range.

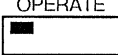
(10) Calibration for the 1000 mV range (divider)



(CAL 1000 mV range Zero output)

- ① Press the  key, measure the generation voltage (Zero output) on the DMM (in 100 nV resolution), and enter data from the entry key section.
(Enter data in units of mV.)





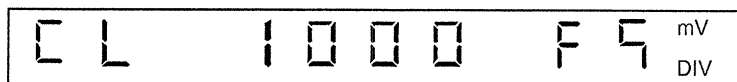



For example, press keys       and  in this sequence.

- ② Press the  key.



(CAL 1000 mV range F.S output)

- ③ Press the  key, measure the generation voltage (F.S output) on the DMM (in 1 μ V resolution), and enter data from the entry key section.
(Enter data in units of mV.)





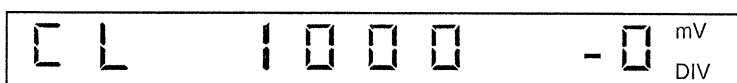

For example, press keys        and  in this sequence.

- ④ Press the  key.



(CAL 1000 mV range -Zero output)

- ⑤ Press the  key, measure the generation voltage (-Zero output) on the DMM (in 100 nV resolution), and enter data from the entry key section.
(Enter data in units of mV.)

For example, press keys       and  in this sequence.
(-)

- ⑥ Press the key.

CL	1000	-F5	mV DIV
(CAL	1000 mV range	-F.S output)	

- ⑦ Press the key, measure the generation voltage (–F.S output) on the DMM (in 1 μ V resolution), and enter data from the entry key section.
(Enter data in units of mV.)

For example, press keys and in this sequence.
(-)

The calibration for the 1000 mV range has been completed.

- ⑧ Press the key.

Switch to the 1 mA range.

(11) Connect the standard resistor (1 kΩ) across the ± OUTPUT terminal.
(Voltage drop method)

(12) Calibration for the 1 mA range

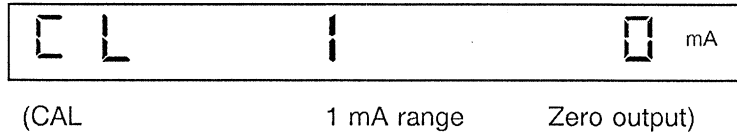

CAUTION

- Cable connection (Voltage drop method)

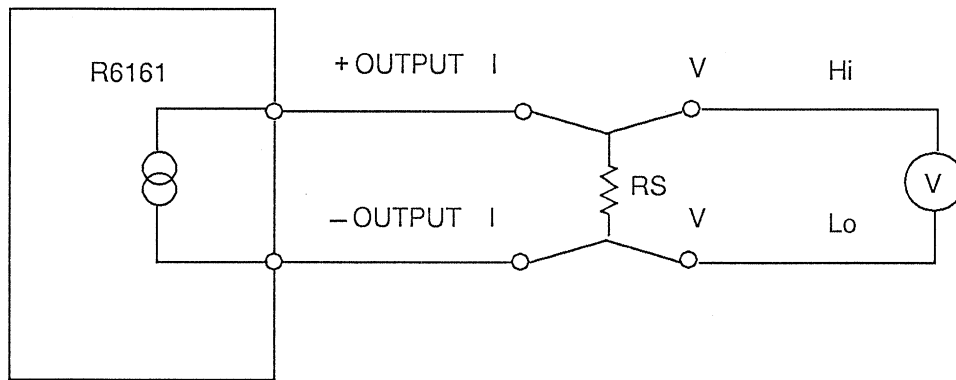









- Connect an Digital current meter between the +OUTPUT and -OUTPUT terminals if a highly accurate one is available.



① Press the  key, measure the generation ^(*) current (Zero output) on the DMM (in 1 nA or 1 μV resolution), and enter data from the entry key section.
(Enter data in units of mA.)

*1: Use the voltage drop method for calculation into current.

$$\text{Calculated current} = \frac{\text{Readout on digital voltmeter}}{\text{Calibration value (RS) of standard resistor}}$$

$R_S = 1 \text{ k}\Omega$

For example, press keys        and  in this sequence.

 1 μA  1 nA

- ② Press the key.

CL	1	F 5 mA
(CAL	1 mA range	F.S output)

- ③ Press the key, measure the generation current (F.S output) on the DMM (in 1 nA resolution), and enter data from the entry key section.
(Enter data in units of mA.)

For example, press keys and in this sequence.

↑ ↑ ↑
 1 μA 1 nA

- ④ Press the key.

CL	1	- 0 mA
(CAL	1 mA range	-Zero output)

- ⑤ Press the key, measure the generation current (-Zero output) on the DMM (in 1 nA resolution), and enter data from the entry key section.
(Enter data in units of mA.)

For example, press keys and in this sequence.

↑ ↑
 1 μA 1 nA

- ⑥ Press the key.

CL	1	- F 5 mA
(CAL	1 mA range	-F.S output)

- ⑦ Press the OPERATE key, measure the generation current (–F.S output) on the DMM (in 1 nA resolution), and enter data from the entry key section.
(Enter data in units of mA.)

For example, press keys +/- 1 . 0 0 1 2 6 3 and ENTER in this sequence.

(-)

↑ ↑

1 μA 1 nA

The calibration for the 1 mA range has been completed.

- ⑧ Press the ↑ key.

Switch to the 10 mA range.

(13) Connect the standard resistor (100 Ω) across the ± OUTPUT terminals.
(Voltage drop method)



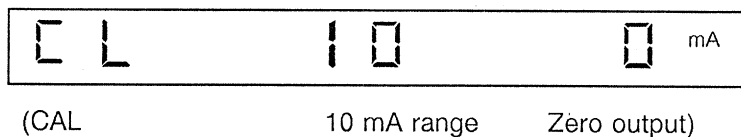





(14) Calibration for the 10 mA range





- ① Press the  key, measure the generation (*1) current (Zero output) on the DMM (in 10 nA or 10 μV resolution), and enter data from the entry key section.
(Enter data in units of mA.)

$$*1 \quad \text{Calculated current} = \frac{\text{Readout on digital voltmeter}}{\text{Calibration value (RS) of standard resistor}}$$

RS = 100 Ω







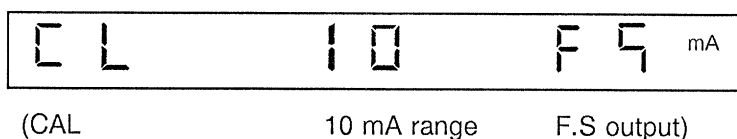

For example, press keys        and  in this sequence.



 10 μA  10 nA

- ② Press the  key.



- ③ Press the  key, measure the generation current (F.S output) on the DMM (in 10 nA resolution), and enter data from the entry key section.
(Enter data in units of mA.)

For example, press keys        and  in this sequence.

 10 μA  10 nA

(15) Connect the standard resistor (10 Ω) between the + OUTPUT and – OUTPUT terminals.
(Voltage drop method)

(16) Calibration for the 100 mA range





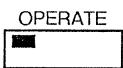



(CAL 100 mA range Zero output)

- ① Press the  key, measure the generation (*1) current (Zero output) on the DMM (in 100 nA or 100 μV resolution), and enter data from the entry key section.
(Enter data in units of mA.)

$$*1 \text{ Calculated current} = \frac{\text{Readout on digital voltmeter}}{\text{Calibration value (RS) of standard resistor}}$$

RS = 10 Ω

For example, press keys       and  in this sequence.

↑ ↑
100 μA 100 nA





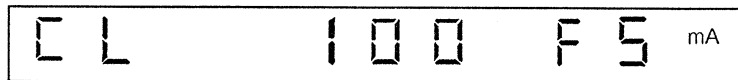

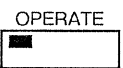

The data about 60 seconds after the operation is follows:

- ② Press the  key.



(CAL 100 mA range F.S output)

- ③ Press the  key, measure the generation current (F.S output) on the DMM (in 100 nA resolution), and enter data from the entry key section.
(Enter data in units of mA.)

For example, press keys         and  in this sequence.

↑ ↑
100 μA 100 nA

(17) Connect a digital multimeter (DMM) to the + OUTPUT and – OUTPUT terminals.

(18) Calibration for voltage limit

CL	VL	V
(CAL	V Limit)

CAUTION

Approximately 500 V voltage is generated (and the HIGH V lamp lights).

- ① Press the OPERATE key, measure the generation voltage (approximately 500 V) on the DMM (in 0.1 V resolution), and enter data from the entry key section.
(Enter data in units of V.)

For example, press keys 5 0 7 . 1 and ENTER in this sequence.

The voltage limit calibration has been completed.

- ② Press the ↑ key.

Switch to the current limit calibration.

(19) Connect the standard resistor (10-ohm) to the + OUTPUT and – OUTPUT terminals.
(Voltage drop method)

(20) Calibration for the current limit

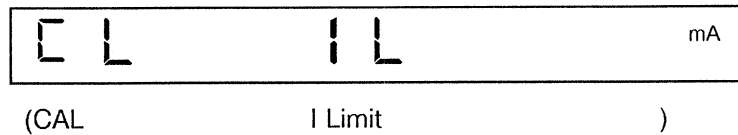

CAUTION

- The digital multimeter (DMM) can measure the current for current limit.
Measuring range: 100 mA
Display digits: 000.00 mA
Input resistance: 10 Ω or less
- Cable connection using voltage drop method

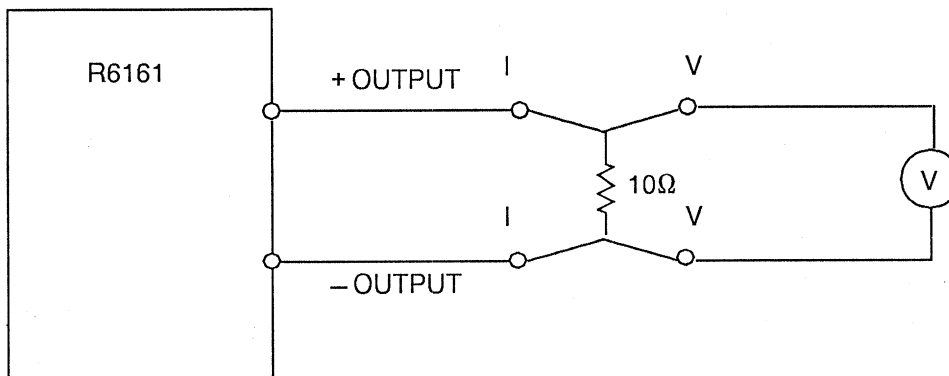

① Press the key, measure the generation voltage (approximately 0.5 V output) on the DMM (in 100 μV resolution), and enter data from the entry key section.
(The generation voltage must be converted into current and entered.)

Press keys and in this sequence.

$$\text{Calculated current} = \frac{\text{Readout on digital voltmeter}}{10 \Omega \text{ calibration value}} = 50.75 \text{ mA}$$

(21) Press the key, and the `CAL End` message will be displayed and the each calibrated coefficient will be written in the EEPROM.
(This message blinks when data writing has completed.)

(22) Set the EXT CAL switch to the DISABLE position. The calibration has completed.

8. SPECIFICATIONS

8.1 DC Voltage/Current Output Specifications

(1) Generation range:

The voltage or current can be generated in the overrange that is 1.2 times larger than full range.

RANGE	Generation range	Minimum step
10 mV (Divider on)	0 to ± 11.99999 mV	10 nV
100 mV (Divider on)	0 to ± 119.9999 mV	100 nV
1000 mV (Divider on)	0 to ± 1199.999 mV	1 μ V
1 V	0 to ± 1.199999 V	1 μ V
10 V	0 to ± 11.99999 V	10 μ V
100 V	0 to ± 119.9999 V	100 μ V
1000 V	0 to ± 1199.999 V	1 mV
1 mA	0 to ± 1.199999 mA	1 nA
10 mA	0 to ± 11.99999 mA	10 nA
100 mA	0 to ± 119.9999 mA	100 nA

(2) Total accuracy:

The accuracy including the external standards, traceability, calibration error, stability, temperature coefficient, long term stability, linearity, and noise ripple (DC to 1 Hz). (The line regulation and load regulation are not included.)

The accuracy is assured in the conditions where the Generator is preheated more than one hour in the temperature of $23 \pm 5^\circ\text{C}$ and relative humidity of 70% or less.

The current range is assured in the output compliance ± 10 V or less.

- Total accuracy in a day

RANGE	Error (Ⓐ + Ⓑ)	
	Ⓐ Setting error	Ⓑ Range error
10 mV (Divider on)	$\pm 0.0055\%$	$\pm 0.7 \mu\text{V}$
100 mV (Divider on)	$\pm 0.0040\%$	$\pm 0.8 \mu\text{V}$
1000 mV (Divider on)	$\pm 0.0030\%$	$\pm 6 \mu\text{V}$
1 V	$\pm 0.0020\%$	$\pm 10 \mu\text{V}$
10 V	$\pm 0.0020\%$	$\pm 60 \mu\text{V}$
100 V	$\pm 0.0020\%$	$\pm 600 \mu\text{V}$
1000 V	$\pm 0.0025\%$	$\pm 6 \text{ mV}$
1 mA	$\pm 0.0055\%$	$\pm 9 \text{ nA}$
10 mA	$\pm 0.0040\%$	$\pm 90 \text{ nA}$
100 mA	$\pm 0.0040\%$	$\pm 900 \text{ nA}$

**R6161 PROGRAMMABLE REFERENCE
DC VOLTAGE/CURRENT GENERATOR
INSTRUCTION MANUAL**

8.1 DC Voltage/Current Output Specifications

- Total accuracy in 90 days

RANGE	Error (Ⓐ + Ⓑ)	
	Ⓐ Setting error	Ⓑ Range error
10 mV (Divider on)	± 0.0060%	± 2.3 μV
100 mV (Divider on)	± 0.0045%	± 2.5 μV
1000 mV (Divider on)	± 0.0035%	± 8 μV
1 V	± 0.0025%	± 11 μV
10 V	± 0.0025%	± 70 μV
100 V	± 0.0025%	± 700 μV
1000 V	± 0.0030%	± 7 mV
1 mA	± 0.0060%	± 9 nA
10 mA	± 0.0045%	± 90 nA
100 mA	± 0.0045%	± 900 nA

- Total accuracy in 180 days

RANGE	Error (Ⓐ + Ⓑ)	
	Ⓐ Setting error	Ⓑ Range error
10 mV (Divider on)	± 0.0065%	± 2.3 μV
100 mV (Divider on)	± 0.0050%	± 2.5 μV
1000 mV (Divider on)	± 0.0040%	± 8 μV
1 V	± 0.0030%	± 12 μV
10 V	± 0.0030%	± 70 μV
100 V	± 0.0030%	± 700 μV
1000 V	± 0.0035%	± 7 mV
1 mA	± 0.0065%	± 9 nA
10 mA	± 0.0050%	± 90 nA
100 mA	± 0.0050%	± 900 nA

**R6161 PROGRAMMABLE REFERENCE
DC VOLTAGE/CURRENT GENERATOR
INSTRUCTION MANUAL**

8.1 DC Voltage/Current Output Specifications

(3) Relative accuracy:

The relative accuracy is equal to the total accuracy excluding the traceability of external standards. That is, the relative accuracy includes the calibration error, stability, temperature coefficient, long term stability, linearity, and noise ripple (DC to 1 Hz). (The line regulation and load regulation are not included.)

The accuracy is assured in the conditions where the Generator is preheated more than one hour in the temperature of $23 \pm 1^\circ\text{C}$ and relative humidity of 70% or less.

- Total accuracy in a day

RANGE	Error (Ⓐ + Ⓑ)	
	Ⓐ Setting error	Ⓑ Range error
10 mV (Divider on)	$\pm 0.0010\%$	$\pm 0.5 \mu\text{V}$
100 mV (Divider on)	$\pm 0.0010\%$	$\pm 0.5\mu\text{V}$
1000 mV (Divider on)	$\pm 0.0010\%$	$\pm 4 \mu\text{V}$
1 V	$\pm 0.0005\%$	$\pm 6 \mu\text{V}$
10 V	$\pm 0.0005\%$	$\pm 40 \mu\text{V}$
100 V	$\pm 0.0005\%$	$\pm 400 \mu\text{V}$
1000 V	$\pm 0.0008\%$	$\pm 4 \text{ mV}$
1 mA	$\pm 0.0015\%$	$\pm 5 \text{ nA}$
10 mA	$\pm 0.0010\%$	$\pm 50 \text{ nA}$
100 mA	$\pm 0.0010\%$	$\pm 500 \text{ nA}$

- Total accuracy in 90 days

RANGE	Error (Ⓐ + Ⓑ)	
	Ⓐ Setting error	Ⓑ Range error
10 mV (Divider on)	$\pm 0.0020\%$	$\pm 2 \mu\text{V}$
100 mV (Divider on)	$\pm 0.0020\%$	$\pm 2 \mu\text{V}$
1000 mV (Divider on)	$\pm 0.0020\%$	$\pm 6 \mu\text{V}$
1 V	$\pm 0.0015\%$	$\pm 8 \mu\text{V}$
10 V	$\pm 0.0015\%$	$\pm 50 \mu\text{V}$
100 V	$\pm 0.0015\%$	$\pm 500 \mu\text{V}$
1000 V	$\pm 0.0015\%$	$\pm 5 \text{ mV}$
1 mA	$\pm 0.0025\%$	$\pm 6 \text{ nA}$
10 mA	$\pm 0.0020\%$	$\pm 60 \text{ nA}$
100 mA	$\pm 0.0020\%$	$\pm 600 \text{ nA}$

**R6161 PROGRAMMABLE REFERENCE
DC VOLTAGE/CURRENT GENERATOR
INSTRUCTION MANUAL**

8.1 DC Voltage/Current Output Specifications

- Total accuracy in 180 days

RANGE	Error (Ⓐ + Ⓑ)	
	Ⓐ Setting error	Ⓑ Range error
10 mV (Divider on)	± 0.0025%	± 2 μV
100 mV (Divider on)	± 0.0025%	± 2 μV
1000 mV (Divider on)	± 0.0025%	± 6 μV
1 V	± 0.0020%	± 9 μV
10 V	± 0.0020%	± 50 μV
100 V	± 0.0020%	± 500 μV
1000 V	± 0.0020%	± 5 mV
1 mA	± 0.0030%	± 6 nA
10 mA	± 0.0025%	± 60 nA
100 mA	± 0.0025%	± 600 nA

(4) Stability in a day:

The stability in a day is assured in the conditions where the Generator is preheated more than one hour in the temperature of $23 \pm 1^\circ\text{C}$ and relative humidity of 70% or less and where the source power and loads are fixed.

The current range is assured in the output compliance $\pm 10\text{ V}$ or less.

RANGE	Error (Ⓐ + Ⓑ)	
	Ⓐ Setting error	Ⓑ Range error
10 mV (Divider on)	± 0.0007%	± 0.3 μV
100 mV (Divider on)	± 0.0007%	± 0.3 μV
1000 mV (Divider on)	± 0.0007%	± 2 μV
1 V	± 0.0005%	± 3 μV
10 V	± 0.0005%	± 20 μV
100 V	± 0.0005%	± 200 μV
1000 V	± 0.0005%	± 2 mV
1 mA	± 0.0012%	± 2 nA
10 mA	± 0.0007%	± 20 nA
100 mA	± 0.0007%	± 200 nA

**R6161 PROGRAMMABLE REFERENCE
DC VOLTAGE/CURRENT GENERATOR
INSTRUCTION MANUAL**

8.1 DC Voltage/Current Output Specifications

(5) Temperature coefficient 1:

Temperature coefficient 1 is assured in the conditions where the Generator is preheated more than one hour in the temperature of $23 \pm 10^{\circ}\text{C}$ and relative humidity of 70% or less and where the source power and loads are fixed.

RANGE	Error (A + B)	
	A Setting error	B Range error
10 mV (Divider on)	$\pm 0.0004\%/^{\circ}\text{C}$	$\pm 0.01 \mu\text{V}/^{\circ}\text{C}$
100 mV (Divider on)	$\pm 0.0004\%/^{\circ}\text{C}$	$\pm 0.07 \mu\text{V}/^{\circ}\text{C}$
1000 mV (Divider on)	$\pm 0.0004\%/^{\circ}\text{C}$	$\pm 0.6 \mu\text{V}/^{\circ}\text{C}$
1 V	$\pm 0.0002\%/^{\circ}\text{C}$	$\pm 1 \mu\text{V}/^{\circ}\text{C}$
10 V	$\pm 0.0002\%/^{\circ}\text{C}$	$\pm 6 \mu\text{V}/^{\circ}\text{C}$
100 V	$\pm 0.0002\%/^{\circ}\text{C}$	$\pm 60 \mu\text{V}/^{\circ}\text{C}$
1000 V	$\pm 0.0003\%/^{\circ}\text{C}$	$\pm 600 \mu\text{V}/^{\circ}\text{C}$
1 mA	$\pm 0.0006\%/^{\circ}\text{C}$	$\pm 0.7 \text{ nA}/^{\circ}\text{C}$
10 mA	$\pm 0.0004\%/^{\circ}\text{C}$	$\pm 7 \text{ nA}/^{\circ}\text{C}$
100 mA	$\pm 0.0004\%/^{\circ}\text{C}$	$\pm 70 \text{ nA}/^{\circ}\text{C}$

(6) Temperature coefficient 2:

Temperature coefficient 2 is assured in the conditions where the Generator is preheated more than one hour in the temperature of 0 to $+13^{\circ}\text{C}$ or $+33$ to $+40^{\circ}\text{C}$ and relative humidity of 70% or less and where the source power and loads are fixed.

RANGE	Error (A + B)	
	A Setting error	B Range error
10 mV (Divider on)	$\pm 0.0005\%/^{\circ}\text{C}$	$\pm 0.03 \mu\text{V}/^{\circ}\text{C}$
100 mV (Divider on)	$\pm 0.0005\%/^{\circ}\text{C}$	$\pm 0.08 \mu\text{V}/^{\circ}\text{C}$
1000 mV (Divider on)	$\pm 0.0005\%/^{\circ}\text{C}$	$\pm 0.8 \mu\text{V}/^{\circ}\text{C}$
1 V	$\pm 0.0004\%/^{\circ}\text{C}$	$\pm 1.5 \mu\text{V}/^{\circ}\text{C}$
10 V	$\pm 0.0004\%/^{\circ}\text{C}$	$\pm 8 \mu\text{V}/^{\circ}\text{C}$
100 V	$\pm 0.0004\%/^{\circ}\text{C}$	$\pm 80 \mu\text{V}/^{\circ}\text{C}$
1000 V	$\pm 0.0005\%/^{\circ}\text{C}$	$\pm 800 \mu\text{V}/^{\circ}\text{C}$
1 mA	$\pm 0.0008\%/^{\circ}\text{C}$	$\pm 0.8 \text{ nA}/^{\circ}\text{C}$
10 mA	$\pm 0.0005\%/^{\circ}\text{C}$	$\pm 8 \text{ nA}/^{\circ}\text{C}$
100 mA	$\pm 0.0005\%/^{\circ}\text{C}$	$\pm 80 \text{ nA}/^{\circ}\text{C}$

**R6161 PROGRAMMABLE REFERENCE
DC VOLTAGE/CURRENT GENERATOR
INSTRUCTION MANUAL**

8.1 DC Voltage/Current Output Specifications

(7) Linearity:

The linearity is assured in the conditions where the Generator is preheated more than one hour in the temperature of $23 \pm 10^{\circ}\text{C}$ and relative humidity of 70% or less and where the source power and loads are fixed.

The current range is assured in the output compliance $\pm 10\text{ V}$ or less.

RANGE	Linearity error
10 mV (Divider on)	$\pm 0.03\ \mu\text{V}$
100 mV (Divider on)	$\pm 0.3\ \mu\text{V}$
1000 mV (Divider on)	$\pm 4\ \mu\text{V}$
1 V	$\pm 3\ \mu\text{V}$
10 V	$\pm 30\ \mu\text{V}$
100 V	$\pm 400\ \mu\text{V}$
1000 V	$\pm 5\text{ mV}$
1 mA	$\pm 3\text{ nA}$
10 mA	$\pm 30\text{ nA}$
100 mA	$\pm 500\text{ nA}$

(8) Noise ripple:

The current range is assured in the 1k-ohm load resistance.

RANGE	0.1 Hz to 10 Hz (rms)	10 Hz to 10 kHz (rms)	DC to 20 MHz (P-P)
10 mV (Divider on)	0.2 μV	20 μV	1 mV
100 mV (Divider on)	0.5 μV	20 μV	1 mV
1000 mV (Divider on)	1 μV	20 μV	1 mV
1 V	2 μV	100 μV	3 mV
10 V	10 μV	100 μV	3 mV
100 V	100 μV	100 μV	3 mV
1000 V	1 mV	1 mV	10 mV
1 mA	5 nA	50 nA	2 μA
10 mA	20 nA	200 nA	2 μA
100 mA	200 nA	500 nA	10 μA

Note : The measurement condition of high frequency noise (- 20MHz) is follows.

R6161 ;The lamp of EXT.GUARD and EXT.SENSE being turned off.

Oscilloscope ;20MHz band pass filters are on.

The ground connection of the probe point (output side) is assumed to be the shortest connection.

R6161 PROGRAMMABLE REFERENCE
DC VOLTAGE/CURRENT GENERATOR
INSTRUCTION MANUAL

8.1 DC Voltage/Current Output Specifications

(9) Settling time:

The time to reach the target value $\pm 0.001\%$ (in the 100 mA range, it is the time to reach the target value $\pm 0.0015\%$).

RANGE	Settling time	Load conditions
10 mV (Divider on)	1 sec	
100 mV (Divider on)	1 sec	
1000 mV (Divider on)	1 sec	
1 V	1 sec	
10 V	1 sec	
100 V	1 sec	
1000 V	* 10 sec	
1 mA	1 sec	100 k Ω or less
10 mA	1 sec	10 k Ω or less
100 mA	1 sec	1 k Ω or less

* In the 1000 V range, the time to reach the target value $\pm 0.05\%$ is 3 seconds or less.

If option 01 (1/10 mA range) is installed, the time to reach the target value $\pm 0.005\%$ is 5 seconds or less (in the load conditions of 1M ohms or 100k ohms, respectively).

(10) Maximum output current :

RANGE	Maximum output current
1 V	± 120 mA
10 V	± 120 mA
100 V	± 120 mA
1000 V	± 12 mA

(11) Maximum output compliance voltage:

RANGE	Maximum output compliance voltage
1 mA	± 120 V
10 mA	± 120 V
100 mA	± 120 V

Option 01(1/10 mA range) output compliance: ± 1200 V

**R6161 PROGRAMMABLE REFERENCE
DC VOLTAGE/CURRENT GENERATOR
INSTRUCTION MANUAL**

8.1 DC Voltage/Current Output Specifications

(12) Load regulation (output resistance):

RANGE	Load regulation (load conditions)	Output resistance (*)
10 mV (Divider on)		200 Ω ± 0.5 %
100 mV (Divider on)		200 Ω ± 0.5 %
1000 mV (Divider on)		200 Ω ± 0.5 %
1 V	± 0.0008% (10 Ω or more)	100 mΩ or less
10 V	± 0.0002% (100 Ω or more)	100 mΩ or less
100 V	± 0.0002% (1 kΩ or more)	100 mΩ or less
1000 V	± 0.0002% (100 kΩ or more)	100 mΩ or less
1 mA	± 0.0002% (10 kΩ or less)	5 GΩ or more
10 mA	± 0.0002% (1 kΩ or less)	5 GΩ or more
100 mA	± 0.0002% (100 Ω or less)	1 GΩ or more

* In the output terminal on EXT. SENSE "OFF" (2-wire connection)

(13) Line regulation:

± 0.0003% during variation of 100 VAC ± 10%

8.2 Voltage/Current Limiter

- Voltage limiter setting range: 10 to 1250 V (in 10 V resolution)
- Voltage limiter setting accuracy: $\pm 3\%$ of setting ± 5 V
- Current limiter setting range: 1 to 125 mA (in 1 mA resolution)
- Current limiter setting accuracy: $\pm 3\%$ of setting ± 0.8 mA
- Common mode noise rejection rate:
Between –OUTPUT/–SENSE and GUARD terminals with 1 k Ω unbalanced impedance
DC: 140 dB or more
50/60 Hz $\pm 1\%$: 80 dB or more

8.3 Program Functions

- Built-in program memory
 - Backup memory: 100 channels
 - The Recall functions for Random Scan, Step Scan, Single Scan, and Repeat Scan can be used. The start and stop channels can be set.
 - Step time: 1 to 99 sec
 - Accuracy: Within $\pm 7\%$ of the set time
 - This accuracy is satisfied when the Step time is 3 sec or more. However, it is satisfied when the Step time is 1 sec or more if the range, function, and polarity are not switched.
- Continuous variable functions:
 - The high-order digits above any digit can be changed continuously.
 - (They cannot be used in the Memory or Recall mode.)

8.4 I/O Functions

- Output format:
Floating, unipolar output
- Maximum applied voltage between terminals :
Between + OUTPUT/+ SENSE and -OUTPUT/-SENSE terminals:
For positive polarity (+): -0.5 to +V₀ [V peak]
For negative polarity (-): +0.5 to -V₀ [V peak]
* : For V₀, use either the set voltage generator value or the voltage limit value, whichever is smaller.
Between HI and LO of DIVID OUT terminals: 2 V peak
Between OUTPUT and SENSE terminals: 0.5 V peak
Between - OUTPUT/- SENSE and GUARD terminals: 50 V peak
Between + OUTPUT/+ SENSE and GROUND terminals: 1200 V peak
Between GUARD and GROUND terminals: 500 V peak
- Maximum remote sensing voltage:
0.1 V including the voltage drop due to the cable resistance between ± OUTPUT and ± SENSE terminals. (The 0.1-V voltage is an error of approximately 10 ppm.)
- Remote sensing method:
The 4-wire or 2-wire line is selected by the key.
- GPIB interface:
Satisfies the IEEE STD488-1978 standards.
SH1, AH1, T6, L3, SR1, RL1, PP0, DC1, DT1, C0, E2
- BCD interface:
Voltage/current generation, output value, range, polarity, limit setup, Operate/Standby status
- Single line signals:
Trigger input: Starts the program operation.

8.5 System Specifications

Display:

Generation set value: (Polarity), 7-digit, 7-segment (green) LED, and unit display

Limiter set value: 6-digit 7-segment (green) LED, and unit display

Parameter setup: 2-digit 7-segment (green) LED, Sec, CH, STEP, SGL, and RPT display

Setting method: Ten numeric keys, control dial, and/or GPIB/BCD remote control setup

Warmup time: One hour or more to enter the specified accuracy

Operating environment:

Operating temperature range: 0 to +40°C; relative humidity: 70% or less

(Operating temperature range: 0 to +35°C; relative humidity: 85% or less)

Storage temperature range: -25 to +70°C

Power supply: The Generator source voltage is determined during ordering.

Option No.	Standard	32	42	44
Source voltage (V)	90 to 110	103 to 132	198 to 242	207 to 250

48 to 66 Hz, 110 VA or less

Dimensions: Approx. 424W × 132H × 450D mm

Weight: 17.5 kg or less

APPENDIX

A1.1 GPIB Remote Control Execution Time

A1.1.1 Processing Method (for Model 16 of HP200 Series)

1: Receive (Listener)

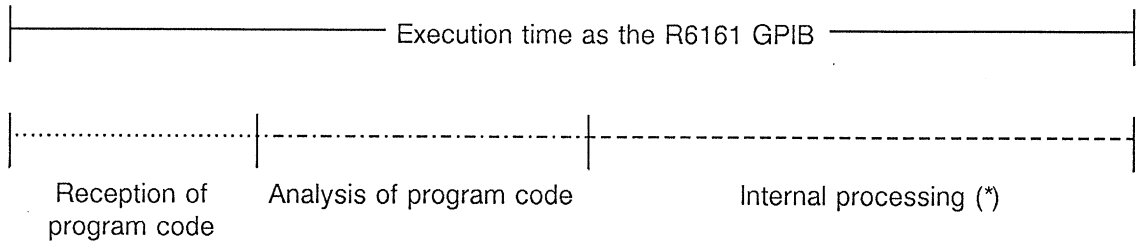

Execution time as R6161 GPIB = GPIB receive interrupt of R6161

Time that can be seen from a peripheral:
The time of R6161 if it is installed as the system

* The time required to start sending the analysis result to the hardware of the output generator

2: Send (Talker)

- Sends data for each character when a BO (Byte Output) interrupt request is issued by the controller.
- The output data is edited in the timing of "?" (Query).

CAUTION

The system throughput is roughly determined by the output operating timing of Section 3.4.

R6161 PROGRAMMABLE REFERENCE
DC VOLTAGE/CURRENT GENERATOR
INSTRUCTION MANUAL

A1.1 GPIB Remote Control Execution Time

A1.1.2 Program Code Execution Time (for Model 16 of HP200 Series)

Function/Name	Program code	Handshake time (receiving time for data)	Time to start internal processing after reception
Operate Standby	OP , E SB , H	Approx. 2.5 msec	Approx. 2.4 msec
Function/Range	V2 V3 V9 V4 V5 V6 V7 I1 I2 I3	Approx. 2.8 msec	Approx. 3.3 msec
Switch of sense	SEN0 SEN1	Approx. 3.4 msec	Approx. 2.4 msec
Switch of guard	GRD0 GRD1	Approx. 3.4 msec	Approx. 2 msec
Memory function	STM○○	Approx. 4.1 msec	—
	SC○○,△△	Approx. 7.1 msec	—
Control of program mode	STT , *TRG PAU , ST0 STT , ST1 STP , ST2	Approx. 4 msec	—
Block delimiter	DL0 DL1 DL2 DL3	Approx. 4 msec	—
Use/no use of service request	S1 S0	Approx. 3.2 msec	—
Clear/mask of status byte	*CLS	Approx. 4.8 msec	—
	SMS○○○	Approx. 6.3 msec	—
Initialization	C	Approx. 2 msec	Approx. 2.3 msec
R6161 initialization	Z , *RST	Approx. 1.9 msec	Approx. 2.9 msec
Limit value setup	VLO○○○ ILO○○○	Approx. 4.1 msec	Approx. 33 msec

R6161 PROGRAMMABLE REFERENCE
DC VOLTAGE/CURRENT GENERATOR
INSTRUCTION MANUAL

A1.1 GPIB Remote Control Execution Time

Function/Name	Program code	Handshake time (receiving time for data)	Time to start internal processing after reception
Store of generation value in specified channel	MEM ①, ②, ③, ④, ⑤ ①: Channel ②: Range ③: Generation value ④: V limit ⑤: I limit	Approx. 24.5 msec	—
	Abbreviated format	Approx. 15.8 msec	—
Direct data setup	D+○○○○○○○○○○ D-○○○○○○○○○○ ● Same polarity in fixed range 1 V F.S 100 mA F.S ● Reverse polarity in fixed range +1 V F.S→-1 V F.S +100 mA→-100 mA	Approx. 7.2 msec	Approx. 12 msec
Execution of recall data	RCLOO ● Same polarity in fixed range 1 V F.S 100 mA F.S ● Reverse polarity in fixed range +1 V F.S→-1 V F.S +100 mA→-100 mA	Approx. 6.2 msec	Approx. 42 msec

**R6161 PROGRAMMABLE REFERENCE
DC VOLTAGE/CURRENT GENERATOR
INSTRUCTION MANUAL**

A1.1 GPIB Remote Control Execution Time

Function/Name	Query code	Handshake time (receiving time for data)	Data send time
Company name, product name, revision	*IDN?	Approx. 5.4 msec	Approx. 19 msec
Contents of block delimiter	DL?	Approx. 4.2 msec	Approx. 5 msec
SRQ send status	SRQ?	Approx. 5 msec	Approx. 6.4 msec
Execution of self-diagnostic test and its result acquisition	*TST?	Approx. 5.4 msec	Approx. 4msec
Contents of status byte	*STB?	Approx. 5.6 msec	Approx. 4.2 msec
Contents of status byte mask register	SMS?	Approx. 4.9 msec	Approx. 5.8 msec
Batch read of panel setup	PANE?	Approx. 5.8 msec	Approx. 26 msec
Data read from specified memory	MEM ○○?	Approx. 6.5 msec	Approx. 28.2 msec

A1.2 BCD Remote Control Execution Time

A1.2.1 Processing Method (for PC-9801) and Execution Time

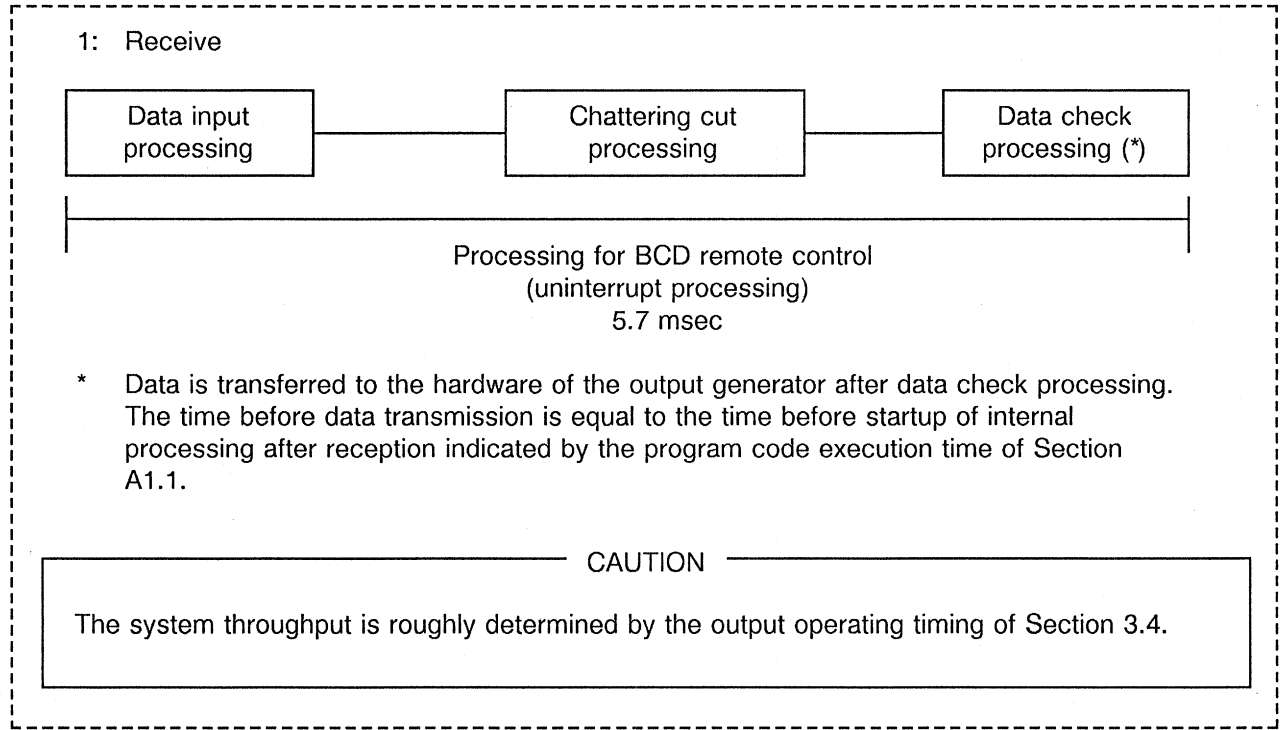

A1.3 Voltage Limit Error during Current Generation

The Generator detects the voltage limit during current generation, and the error may increase in the low limit value.

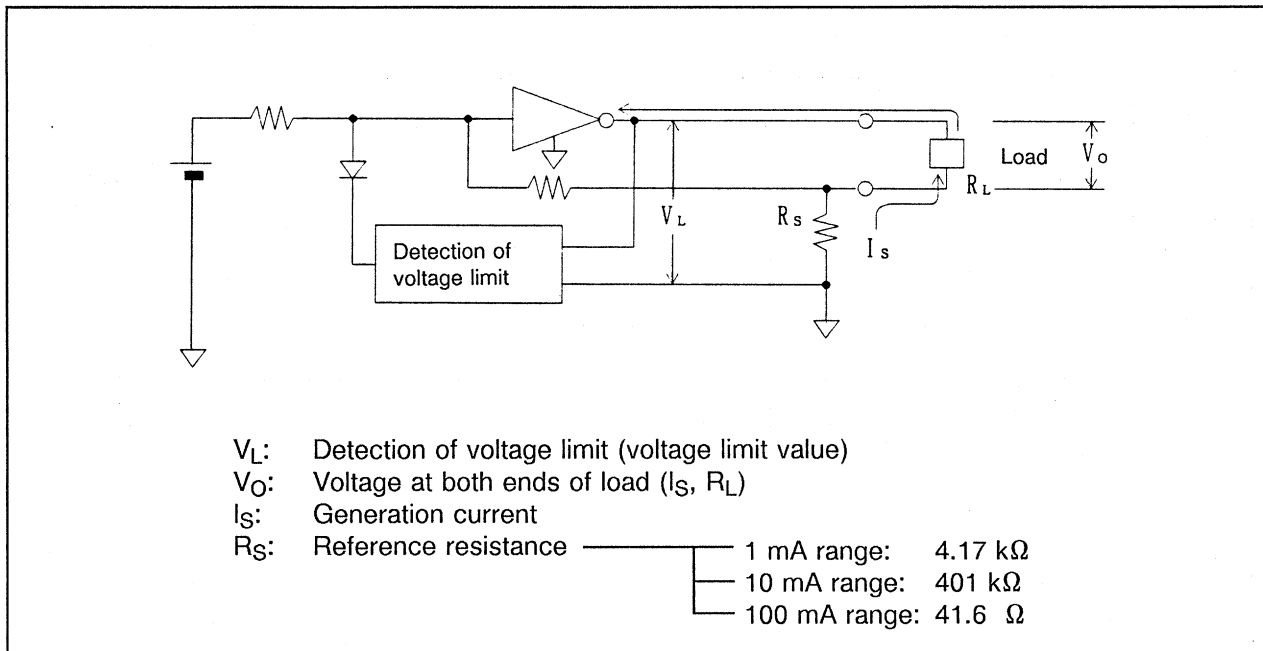

Figure A-1 Voltage Limit Detection Method During Current Generation

From equation " $V_L = V_O - I_S \cdot R_S$ ", the actual voltage at both ends of the load (V_O) is as follows:

$$V_O \doteq \underbrace{V_L}_{\text{Limit set value}} - \underbrace{I_S \cdot R_S}_{\text{Error}}$$

" $I_S \cdot R_S$ " is the error.

Example:

The clamp voltage is as follows if:

$$V_L = 10 \text{ V}$$

$$I_S = 1 \text{ mA (1 mA range)}$$

$$R_L = 20 \text{ k}\Omega$$

$$V_O = 10 \text{ V} - (1 \times 10^{-3} \times 4.17 \times 10^3) = 5.83 \text{ V (Error: 4.17 V)}$$

A1.4 OPR/STBY in 1000V Range or 1mA/10mA Range (Option 01)

- (1) If the limit is detected, the 1000 V range or 1 mA/10 mA range of option 01 is forcibly set to the STBY mode (the output is turned off).
- (2) When the POWER switch is turned on, the voltage limit of the 1000 V range or 1 mA/10 mA range of option 01 is set to 130 V for safety.
To output the voltage greater than 120 V, you must set the limit value greater than the output set value (see Section 3.3.5).
(Also, see Sections 3.3.10 and 3.3.11.)

A1.5 Error List

A1.5.1 List of Panel Setup Error Messages

If an error occurs during setup on the Generator panel, the following error messages may be displayed approximately one second.

Error display	Explanation
E r r . P 0 1	A generation data setup error
E r r . P 0 2	A limit data setup error
E r r . P 0 3	First or last channel error in Program mode (It must be FIRST \leq LAST.)
E r r . P 0 4	An out-of-range error of EXT CAL data
E r r . P 0 5	A channel exceeding two digits was specified in Recall mode.

A1.5.2 GPIB Error Code List

If an error occurs during GPIB code setup on the Generator, the following error messages may be displayed approximately one second.

Error display	Explanation
Err.G01	The specified program code does not match the Generator definition.
Err.G02	The string delimiter does not exist.
Err.G03	An invalid channel number (other than 0 to 99) was specified.
Err.G04	The last channel number is less than the first channel number.
Err.G05	An invalid "X" value (other than 0, 1, 2, or 3) was specified for DLX.
Err.G06	An invalid "X" value (other than 0 to 255) was specified for SMSX.
Err.G07	An invalid "X" value (other than 2 to 7 or 1 to 3) was specified for VX or IX.
Err.G08	An invalid "X" value (other than 10 to 1250) was specified for VLX.
Err.G09	An invalid "X" value (other than 1 to 125) was specified for ILX.
Err.G10	An invalid "X" value (other than 1 to 99) was specified for STMX.
Err.G11	An invalid "X" value (other than 0, 1 or 2) was specified for STX.
Err.G12	No data exists after the D code.
Err.G13	An invalid data was specified after the D code.
Err.G15	A remote control code was received during Ext. CAL.
Err.G16	A VL/IL limit was set in the Divider mode.
Err.G17	Data exceeding 400 characters was entered.
Err.G18	An invalid format of data set was stored in memory.
Err.G20	An invalid remote control code was received in Program mode (Single/Repeat Scan).
Err.GAd	An attempt was made to set 31 or more addresses in the GPIB Address Setup mode.

A1.5.3 List of BCD Remote Control Error Codes

If an error occurs during remote control code setup on the Generator, the following error messages may be displayed approximately one second.

Error display	Explanation
Err.b01	The 1000 V range was selected and the divider was turned on.
Err.b02	The 1000 V range was selected and the I mode was selected.
Err.b03	The divider was turned on and the I mode was selected.
Err.b04	An illegal data was set.

A1.5.4 Error Message List During Self-diagnostic Test and Actions Taken

If one of the following error messages is displayed, your Generator has failed. Contact an ADC CORPORATION sales representative.

Error display	Explanation	Action taken/Status
E r r . 5 r o	A ROM sum check error has occurred.	The error display continues.
E r r . 5 r A	A RAM read/write error has occurred.	The error display continues.
E r r . 5 P r	The battery backed up RAM data was destroyed.	The error message is displayed approximately 5 seconds, <u>the RAM parameters are initialized (see Table 3-1)</u> , and the RAM is returned to the normal operation.
E r r . 5 c L	The calibration data of the electrically erasable programmable ROM (EEPROM) was destroyed.	The error message is displayed approximately 5 seconds, <u>the default values are used as the calibration data</u> (because the calibration data is invalid), and it returns to the normal operation.
E r r . F A n	The fan has stopped.	Caution: Turn the POWER switch off immediately.

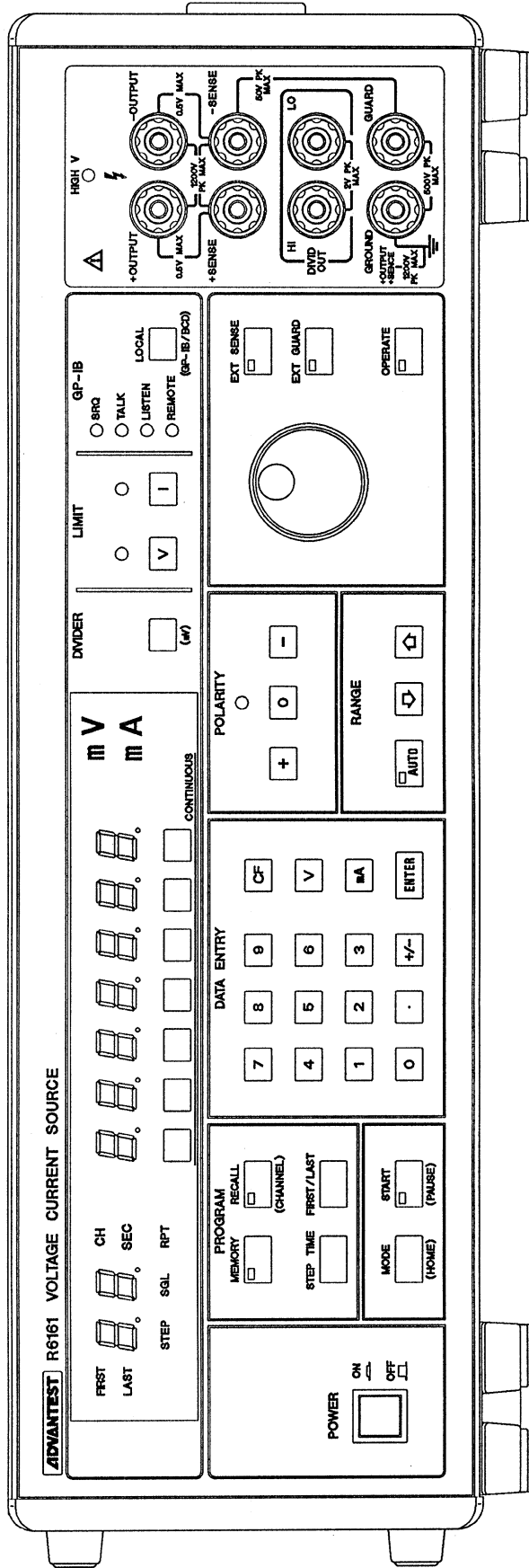

FRONT VIEW

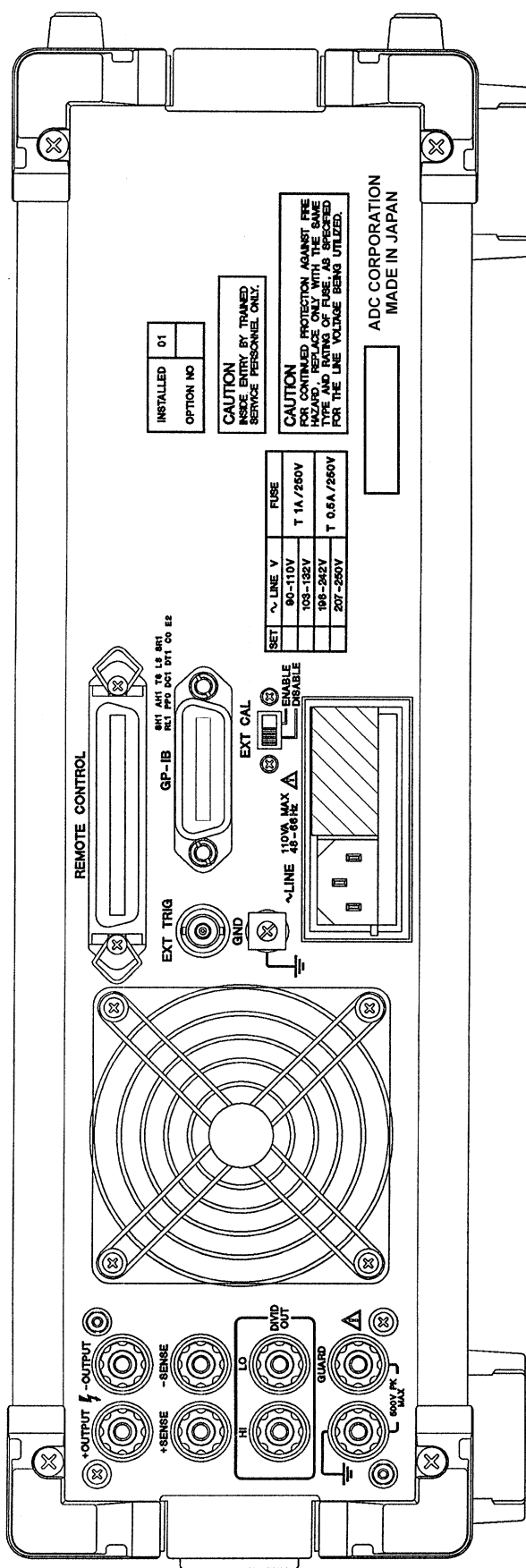

REAR VIEW

ALPHABETICAL INDEX

A		Calibration Procedure	7-5
Accessory	1-1	Changing the Function Key	3-35
Amp Block	6-7*	Changing the Generation Range	3-37
APPENDIX	A1-1	Changing the Polarity	3-38
Appropriate Setup Range	3-10	Changing the Power Voltage	1-7
B		Checking the Accessories	1-1
Batch Read	4-21	Cleaning	1-3
Batch Read of Current Parameter Data	4-21	Command syntax error	4-28, 4-31
BCD REMOTE CONTROL AND INPUT SIGNALS	5-1	Configuration of output terminals	3-14
BCD Remote Control Execution Time	A1-5	Connection to Loads	3-14
Before Calibration	7-2	Connector for AC power supply	2-14
C		CONTINUOUS key	2-2
CALIBRATION	7-1	CONTINUOUS key Operation	3-33
Calibration for 10 V range	7-10	Continuous output function	1-9*
Calibration for 100 V range	7-12	Cooling fan	2-15
Calibration for the 1 mA range	7-22	Current Generation (during direct operation)	3-23
Calibration for the 10 mA range	7-25	D	
Calibration for the 10 mV range (divider)	7-16	Data control knob	2-2, 3-9
Calibration for the 100 mA range	7-27	DATA ENTRY key block	2-11
Calibration for the 100 mV range (divider)	7-18	Data input during direct operation	3-6
Calibration for the 1000 mV range (divider)	7-20	Data input during memory data processing	3-7
Calibration for the 1000 V range	7-14	Data Read from Specified Memory	4-23
Calibration for the current limit	7-30	Data Read from Specified Memory Area	4-26
Calibration for voltage limit	7-29	Data Setup Block	6-3
Calibration in 1 V range	7-8	DC Voltage/Current Output Specification	8-1
Calibration Instruments Required	7-1	Determine the connection coefficient	7-6
Calibration Method	7-4	Device Address and Operation Mode (TR6120A or R6161) Setup	4-8
Calibration Notes	7-3		

**R6161 PROGRAMMABLE REFERENCE
DC VOLTAGE/CURRENT GENERATOR
INSTRUCTION MANUAL**

Alphabetical Index

Display section	2-2	GPIB Specification	4-3
DIVID OUT (Divider Output) terminal	2-5	GPIB status lamp	2-4
Divide (DIV) Output Generation (during direct operation)	3-25	ground	1-4
DIVIDER key	2-2	GROUND terminal	2-5
		GUARD terminal	2-5
E		H	
Electrical Characteristics of Signal	5-6	HIGH V lamp	2-4
Error List	A1-8	HOME key	2-10
Error Message List During Self- diagnostic Test and Actions Taken	A1-11*	How to recall	3-57
Explanation of Basic Operations	3-4	How to recall memory data	3-57
EXT CAL switch	2-15	How to use four terminals	3-14
EXT TRIG input terminal	2-15	How to Use GUARD Terminal	3-18
EXTERNAL GUARD key and lamp	2-8		
EXTERNAL SENSE key and lamp	2-8	I	
EXTERNAL TRIGGER	5-1	I limit range	3-10
External Trigger Input Signal	5-7*	I/O Functions performance and specification	8-11
Fan stop error	4-28, 4-31	Initial Parameter Setup	3-3
First/Last Channel	3-50	Initial Setup Status	3-3
FIRST/LAST key		Interface Function	4-4
for noise protection	3-18	Interface Functions	5-4
Format of Direct Setup Codes for DC Voltage/Current Output	4-19		
Format of Direct Setup Program Codes for DC Voltage/Current Output (R6161 mode)	4-16	L	
Front Panel	2-2	Limit bit (bit 0)	4-29, 4-32
fuse	1-5	LIMIT key	2-3
		Limit operation	4-28, 4-31
		List of BCD Remote Control Error Codes	A1-10
G		List of Functions	1-8
GND terminal	2-14	List of Panel Setup Error Messages	A1-8
GPIB Address Indication	3-1	List of Program Codes (R6161 mode)	4-11
GPIB connector	2-15	List of Program Codes (TR6120A mode)	4-18
GPIB Error Code List	A1-9	LISTEN lamp	2-4
GPIB Interface Application Notes	4-6		
GPIB Remote Control Execution Time	A1-1		

**R6161 PROGRAMMABLE REFERENCE
DC VOLTAGE/CURRENT GENERATOR
INSTRUCTION MANUAL**







Alphabetical Index

Listener Format	4-10	PAUSE key	2-11
LOCAL key	2-4	Pin Assignment of GPIB Interface Connector	4-5
M			
Memory function	1-8	POLARITY	3-9
MEMORY key	2-9	POLARITY [+], [0] and [-] keys	2-12
Memory store	3-53	Power Cable	1-4
Memory store of generation	3-53	Power Fuse	1-5
MODE key	2-10	POWER switch	2-2
O			
OPERATE key	2-7	Power Voltage	1-4
Operating Conditions	1-2	preheating time	1-3
OPERATION PRINCIPLE	6-1	Processing Method (for Model 16 of HP200 Series)	A1-1
Operation with 2-wire or 4-wire line	3-14	Processing Method (for PC-9801) and Execution Time	A1-5
OPR/STBY In 1000V Range or 1mA/10mA Range (Option 01)	A1-7	PROGRAM block key	2-8
Option	1-1	Program Code Execution Time (for Model 16 of HP200 Series)	A1-2
Options	2-14	Program Codes (R6161 mode)	4-10
Outline of GPIB Interface	4-1	Program Codes (TR6120A mode)	4-17
Output Generation (1000V/100V range) and Current Limit Detection	3-40	Program end	4-28
Output generation time during polarity change	3-47	Program end (bit 2)	4-30
Output generation time when Standby status is changed to Operate status	3-45	Program Functions performance and specification	8-10
Output generation time when the function is changed	3-46	Program Operation Flow	3-12
Output generation time when the range is changed	3-45	Programming Example	4-33
Output Operation Timing	3-41	R	
OUTPUT terminal	2-5	Random channel access function	1-8
Output terminal block	2-15	RANGE	3-10
P			
PANEL LAYOUT	2-1	RANGE key block	2-12
Parameter Read Codes (Query)	4-20	Rear Panel	2-14
Parameter Store in Memory (R6161 mode)	4-14	recall display	2-10
		Recall function	1-8
		RECALL key	2-9
		Reference Block	6-4
		REMOTE CONTROL connector	2-15
		REMOTE lamp	2-4

**R6161 PROGRAMMABLE REFERENCE
DC VOLTAGE/CURRENT GENERATOR
INSTRUCTION MANUAL**

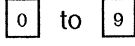
Alphabetical Index

Repeat Scan	3-61	T	
Repeat scan function	1-9*	TALK lamp	2-4
Restrictions on Limit Setup	3-39	Timing when Output Turned on (Operate or Off (Standby))	3-41
Revision Indication	3-1	Timing when the Functions are Changed	3-43
RQS bit	4-28, 4-31	Timing when the Polarity is Changed	3-44
		Timing when the Range is Changed	3-42
		Timing when the Set Data is Changed	3-41
		Transportation	1-3
		Turn the EXT CAL switch ON	7-6
		Turning Power ON	3-1
		V	
		V and I limit function	1-9*
		V limit range	3-10
		Voltage Generation (during direct operation)	3-21
		Voltage Limit Error during Current Generation	A1-6
		Voltage/current limit operation	3-8
		Voltage/Current Limiter performance and specification	8-9
		W	
		Warm-up	1-3
		Z	
		Zero Setup	3-27
S			
Selected power voltage and fuse indication	2-14		
Self-diagnosis	3-1		
Service Request	4-27		
Service Request (SRQ)	4-32		
Setting the Voltage/Current Limit	3-29		
Setup and Usage of Program Function	3-48		
Setup of Power Voltage Card	1-6		
Single Scan	3-60		
Single scan function	1-9*		
SPECIFICATION	8-1		
SRQ lamp	2-4		
START key	2-11		
Start/Pause/Home Control Mode	3-62*		
Start/Pause/Home of Program Operation (in Recall mode)	3-62*		
Status Byte	4-27		
Step	3-59		
Step scan function	1-8		
Step Time	3-48		
STEP TIME key	2-10		
Storage	1-3		
Structure of Status Byte Register (TR6120A mode)	4-31		
Structure of Status Byte Register (R6161 mode)	4-28		
Syntax Error bit (bit 1)	4-29		
System Accessories	1-1		
System Specification	8-12*		

Symbol	
	2-1
	2-1
	2-1
	2-11
	2-11
	2-11
	2-11
	2-11
	2-11
	2-11

IMPORTANT INFORMATION FOR ADC CORPORATION SOFTWARE

PLEASE READ CAREFULLY: This is an important notice for the software defined herein. Computer programs including any additions, modifications and updates thereof, operation manuals, and related materials provided by ADC CORPORATION (hereafter referred to as "SOFTWARE"), included in or used with hardware produced by ADC CORPORATION (hereafter referred to as "PRODUCTS").

SOFTWARE License

All rights in and to the SOFTWARE (including, but not limited to, copyright) shall be and remain vested in ADC CORPORATION. ADC CORPORATION hereby grants you a license to use the SOFTWARE only on or with ADC CORPORATION PRODUCTS.

Restrictions

- (1) You may not use the SOFTWARE for any purpose other than for the use of the PRODUCTS.
- (2) You may not copy, modify, or change, all or any part of, the SOFTWARE without permission from ADC CORPORATION.
- (3) You may not reverse engineer, de-compile, or disassemble, all or any part of, the SOFTWARE.

Liability

ADC CORPORATION shall have no liability(1) for any PRODUCT failures, which may arise out of any misuse (misuse is deemed to be use of the SOFTWARE for purposes other than its intended use) of the SOFTWARE.

(2) For any dispute between you and any third party for any reason whatsoever including, but not limited to, infringement of intellectual property rights.

LIMITED WARRANTY

1. Unless otherwise specifically agreed by Seller and Purchaser in writing, ADC CORPORATION will warrant to the Purchaser that during the Warranty Period this Product (other than consumables included in the Product) will be free from defects in material and workmanship and shall conform to the specifications set forth in this Operation Manual.
2. The warranty period for the Product (the "Warranty Period") will be a period of one year commencing on the delivery date of the Product.
3. If the Product is found to be defective during the Warranty Period, ADC CORPORATION will, at its option and in its sole and absolute discretion, either (a) repair the defective Product or part or component thereof or (b) replace the defective Product or part or component thereof, in either case at ADC CORPORATION's sole cost and expense.
4. This limited warranty will not apply to defects or damage to the Product or any part or component thereof resulting from any of the following:
 - (a) any modifications, maintenance or repairs other than modifications, maintenance or repairs (i) performed by ADC CORPORATION or (ii) specifically recommended or authorized by ADC CORPORATION and performed in accordance with ADC CORPORATION's instructions;
 - (b) any improper or inadequate handling, carriage or storage of the Product by the Purchaser or any third party (other than ADC CORPORATION or its agents);
 - (c) use of the Product under operating conditions or environments different than those specified in the Operation Manual or recommended by ADC CORPORATION, including, without limitation, (i) instances where the Product has been subjected to physical stress or electrical voltage exceeding the permissible range and (ii) instances where the corrosion of electrical circuits or other deterioration was accelerated by exposure to corrosive gases or dusty environments;
 - (d) use of the Product in connection with software, interfaces, products or parts other than software, interfaces, products or parts supplied or recommended by ADC CORPORATION;
 - (e) the occurrence of an event of force majeure, including, without limitation, fire, explosion, geological change, storm, flood, earthquake, tidal wave, lightning or act of war;
 - (f) any negligent act or omission of the Purchaser or any third party other than ADC CORPORATION; or
 - (g) any product exported from a country where the product was sold.

5. EXCEPT TO THE EXTENT EXPRESSLY PROVIDED HEREIN, ADC CORPORATION HEREBY EXPRESSLY DISCLAIMS, AND THE PURCHASER HEREBY WAIVES, ALL WARRANTIES, WHETHER EXPRESS OR IMPLIED, STATUTORY OR OTHERWISE, INCLUDING, WITHOUT LIMITATION, (A) ANY WARRANTY OF MERCHANTABILITY OR FITNESS FOR A PARTICULAR PURPOSE AND (B) ANY WARRANTY OR REPRESENTATION AS TO THE VALIDITY, SCOPE, EFFECTIVENESS OR USEFULNESS OF ANY TECHNOLOGY OR ANY INVENTION.
6. THE REMEDY SET FORTH HEREIN SHALL BE THE SOLE AND EXCLUSIVE REMEDY OF THE PURCHASER FOR BREACH OF WARRANTY WITH RESPECT TO THE PRODUCT.
7. ADC CORPORATION WILL NOT HAVE ANY LIABILITY TO THE PURCHASER FOR ANY INDIRECT, INCIDENTAL, SPECIAL, CONSEQUENTIAL OR PUNITIVE DAMAGES, INCLUDING, WITHOUT LIMITATION, LOSS OF ANTICIPATED PROFITS OR REVENUES, IN ANY AND ALL CIRCUMSTANCES, EVEN IF ADC CORPORATION HAS BEEN ADVISED OF THE POSSIBILITY OF SUCH DAMAGES AND WHETHER ARISING OUT OF BREACH OF CONTRACT, WARRANTY, TORT (INCLUDING, WITHOUT LIMITATION, NEGLIGENCE), STRICT LIABILITY, INDEMNITY, CONTRIBUTION OR OTHERWISE.

CLAIM FOR DAMAGE IN SHIPMENT TO ORIGINAL BUYER

The product should be thoroughly inspected immediately upon original delivery to buyer. If the product is damaged in any way, a claim should be filed by the buyer with carrier immediately.

CUSTOMER SERVICE DESCRIPTION

Contact an ADC CORPORATION sales representative if a failure occurs.

- (1) The repair service lasts ten years from the delivery date of the Product.
- (2) The repair and calibration services may be declined if either of the following situations arise.
 - 1) When required parts cannot be procured.
 - 2) When the performance of the Product cannot be maintained after repair.